

The Effect of Transformational Leadership Style on Teacher's Organizational Commitment

Puspa Liza Ghazali^{1*}, Farah Wahida Jaafar², Asyraf Afthanorhan³, Eni Noreni Mohamad Zain⁴, Roslida Abdul Razak⁵, Mustafa Mamat⁶

^{1,2,3,5}*Faculty of Business and Management, Universiti Sultan Zainal Abidin, Terengganu, Malaysia*

⁴*Faculty of Entrepreneurship and Business, Universiti Malaysia Kelantan, Kelantan, Malaysia*

⁶*Faculty of Informatics and Computing, Universiti Sultan Zainal Abidin, Terengganu, Malaysia.*

Email: ¹puspaliza@unisza.edu.my, ²rah_wahida@yahoo.com,
³asyrafafthanorhan@unisza.edu.my, ⁴noreni@umk.edu.my,
⁵roslida@unisza.edu.my, ⁶must@unisza.edu.my

Abstract

This research aims to examine the mediation effect of emotional intelligence on the relationship of transformational leadership style on teacher's organizational commitment. About 150 respondents among daily secondary school teachers in Terengganu need to answer the questionnaire that has been distributed. Structural Equation Modelling (SEM) were chosen as a method in analyzing, interpret and test the development of the hypotheses. The findings reveal that there's a direct and indirect effect of transformational leadership style on teacher's organizational commitment. Emotional intelligence clearly proved as a mediator in this research. Importantly, results of this study have extended the literature of transformational leadership style, emotional intelligence and teacher's organizational commitment in educational settings.

Keywords: Leadership Style, Role, Emotional Intelligence and Mediator

1. Introduction

Patience leads to an efficient leadership. According to [7], good management of leadership is vital. It's a part of influence others or the followers in achieving the mission and vision together. Leadership style contains attitude, types and several skills. The school principals are responsible to ensure a comfort teaching environment and able to gain an effective learning outcome in schools. Experiences and deeper knowledge in those matters will enhance the development of educational leadership in schools. In [19], stated that the educational leadership based on the principals and school administration's responsibility. Principals try to create the positive changes and effective policies for the better development of education context. Teachers involved in upgrading the level of teaching and learning process. An effective and strategic educational leadership influence the learning process, teaching activities, and the activities in class [33]. Principals giving their excellent services in conducting the school toward success. The way of principal leads the school organization showed how they interact with their teachers and staff. According to [30], each principal has their own style on interacting with the members of

school organization. Teacher's organizational commitment increase if the principals own higher level of emotional intelligence. Emotional intelligence is self-ability on knowing own emotions and others and able to use it on how to react according to the situations.

2. Literature Review

2.1 Transformational Leadership Style and Teacher's Organizational Commitment

According to [1], in their study by using meta-analysis in Turkey to find the impacts of school principals' leadership styles (transformational, transactional and laissez-faire) on job satisfaction and organizational commitment found that the dominant styles had been used were transformational leadership style. It seems that, there's a positive relationship onto teachers' job satisfaction as well as to teacher's organizational commitment. Teacher's job satisfaction and commitment will increase due to the changes made by the school leaders who practice transactional leadership style and turn it to transformational leadership style. Motivation influences the level of job satisfaction and organizational commitment. [9] also defines that transformational leadership style shows significant effect on teacher's job satisfaction as well as their level of commitment. It found that the principals in primary, secondary and high schools in China shows there's a positive vibe on teachers when practised transformational leadership style rather than transactional leadership style. High level of job satisfaction influence the commitment among the teachers. Principals' decision making style moderate the impact on teachers' job satisfaction. [32] also define the same findings on the effectiveness of transformational behavior by the principals. Quantitative study on 237 teachers from eighteen primary schools in Ankara reveals that the transformational principals more efficient compared than transactional principals. Teachers prefer continuance commitment rather than affective and normative commitment. According to [30], in his mix method research, state that the leadership style and teacher's commitment among the primary school teachers in Canada can be seen from the self-values of the principals. This research shows that the values can be as a medium whereas the power of the leadership exist and function very well. The influence of leadership be an interaction function among followers and leader's value. The finding from meta-analysis method that has been done by [1] among the principals and teachers in Turkey reveal that once the transactional leadership change to transformational leadership, the level of job satisfaction and organizational commitment will increase. Other study from [18] also reveals the same finding on the correlation between transformational leadership style and teachers' organizational commitment. Primary school teachers from Ankara preferred transformational leadership style compared than transactional leadership style. There's a significant relationship between transformational leadership styles on teacher's organizational commitment. The finding shows that all four dimensions of transformational leadership obviously predict the teacher's organizational commitment that consisted three dimensions; normative, continuous and affective commitment.

2.2 Transformational Leadership Style and Emotional Intelligence.

Transformational and transactional leadership style showed the significant relationship on emotional intelligence and leadership effectiveness. Emotional intelligence fully mediates the relationship between transformational leadership style and leadership effectiveness while transactional leadership style partially mediates by emotional intelligence. The research was conducted among the employees from the banking sector in Islamabad. It seems that emotional intelligence is the predictor between leadership style and leadership effectiveness. The findings correlated with other previous researcher that also showed leader's emotional intelligence has a significant relationship

with their leadership styles [8]. As indicated by [28] in their research to examine the relationship among transformational leadership style and decision-making styles, determine the moderating role of emotional intelligence in predicting this relationship. The investigation found that emotional intelligence moderates the relationship among transformational leadership style and decision-making styles. The findings strongly showed the positive connection between leadership style and emotional intelligence. Good understanding with their own emotional intelligence will influence the social orientation toward others and maybe will lead to the degree of interpersonal efficiency among the leaders. The research on 365 experienced project leaders in IPD from China define that transformational leadership style correlated with the level of emotional intelligence. [5] said that the understanding with own emotional intelligence significant with the effectiveness leadership in military context. There's a practical implication to used emotional intelligence in order to enhance the leadership style toward effectiveness. Transformational leadership style shows the positive influence on deep acting and negatively related on surface emotional labor action on the research by [3] regarding the leadership and emotional labor among the hospital workers in United States. Efficient leaders are those who practice transformational behavior rather than transactional. Transformational leaders tend to increase the degree of their own emotional intelligence. Therefore, transformational leadership style can be related with all the elements of emotional intelligence [17]. In Pakistan, with the different kind of organizations in services sector; communication, banking, health institution and education define the same findings on leadership style and emotional intelligence. Higher degrees of emotional intelligence on transformational leaders play the main role in enhancing the level of teacher's organizational commitment. It happened because of their awareness in understood their worker's emotion regarding their needs. The leaders need to put respect among their workers. In appreciating their norm and culture will help the level of their organizational commitment.

2.3 Emotional Intelligence and Teacher's Organizational Commitment

Despite there's a theoretical link, there's still little empirical research that investigate the relationship between emotional intelligence and teacher's organizational commitment. It has been found from the different of research study that the leaders who exhibit high degree of emotional intelligence utilize their positive side of emotional intelligence to enhance the quality of their decision in an organization. Good control of organizational setting comes from the degree level of their emotional intelligence. Organizational productivity will be increase because of the good relationship between the leaders and their followers in the organization [10]. The level of leader's emotional intelligence brings up the good inspiration towards their followers. The success of the principals is when they able to create great ideas achieve the school mission and the objectives and increase the level of teacher's motivation towards organization achievement. Those leaders are those who posit high sense of emotional intelligence. Leadership style is the important element in organizational commitment. According to [30], principals need to create a good relationship with the teachers to upgrade the level of commitment and job performance. He defined in his study to examine the connection of principals' leadership style with emotional intelligent. It reveal that the principals with high emotional intelligence tend to influence the positive impact on teachers' organizational commitment. [16], in his study of emotional intelligent used the theory of emotional intelligence proposed by [27] as the conceptual framework. He want to examine the relationship on teacher's job performance and commitment from universities in Pakistan. It defines that emotional intelligent is the significant tool that adjust their emotion and societal challenges. In their study using SEM-PLS on the relationship between emotional intelligent and teachers' job performance found that emotional intelligence has a significant impact on teachers' job

performance. The performance among the teachers related with their trait on emotional intelligence. High emotional intelligence maintaining the positive psychological condition so that, teacher's performance will enhance because of their good controlling of emotional intelligence. It seems that, motivation leads to emotional intelligence. [34], in their quantitative study using SEM found that transformational leadership acts as a mediator in the relation of emotional intelligence and the team outcomes. Information were gathered from 859 employees, working in 55 teams in a South Korean public-sector organization and results were analyzed at the group level. Transformational leadership related with the great emotional intelligence. It reborns the effective leaders in an organization. There are many researchers found that the emotional intelligence has a relationship on the transformational leadership model. The emotional intelligence leaders seems to be more efficient in their job and also capable to create an effective teams. Transformational leadership behaviour helps to rebuild the level of service climate. Furthermore, to becomes high emotional intelligence leaders, they need to be high potential and full of competency. [15], in his study define that the sign of anxiety can be recognized with the higher level from University of Valahia in his conceptual journal state that leaders with high emotional intelligence can detect indication of anxiety. It found that the emphatic ability is significant in leadership. The leaders who can perceive the emotional uncertainties, can increase satisfaction and performance among subordinates and organization. No discussion on the important of leader's leadership styles and leader's quality decision making toward organizational commitment. [11], in his study to investigate the relationship between the emotional intelligence (EI) and transformational leadership practices of academic leaders in Taiwan and the USA. It intends to examine whether cross-cultural differences exist in academic leaders' EI, leadership practices, and the relationship between them. The findings show that US leaders perceived themselves effective than Taiwan leaders. Both them show the significant correlation with emotional intelligence and leadership practices. In leadership practices, both cultures require high emotional intelligent. Transformational leadership style predicted from trait based on emotional intelligence. Emotional intelligence is underlying competence for being an effective academic leader in two comparison cultures. In managerial context, the strong relationship also shown between the leaders' emotional intelligence and employees' organization commitment among the study conducted among all the executives, managers and intermediate subordinates from all department across locally and own company in Malaysia. The leaders' emotional intelligent predict the good commitment among the subordinates in committed through their working load. [2], in their medication study on the pharmacists in Punjab, Pakistan shows the stable emotional intelligence, able to understand own emotion and others, effectively lead on giving fully commitment with their organization. The dimension of emotional intelligence strongly predicts the affective commitment. Emotional appraisal tends to predict the affective commitment. Therefore, the support, appraisal from the supervisor, managers and colleagues brings up their trust and enjoyable working environment. The level of affective commitment in lines with the level of job performance. It seems that job performance is the outcomes of the organizational commitment. The level of organizational commitment among the pharmacist shows the level of job performance in their working context.

3. Methodology

The questionnaires were distributed to 150 daily secondary school teachers in Terengganu. The questionnaire was divided into four sections which are A, B, C, and D. Each item was measured using the Likert scale technique through a 10-point Likert [20,26]. In the section A, the questions explore the demographic profiles of the

respondents. It consisted of the respondent's profiles such as gender, age, educational background and teaching experiences as a teacher. The demographic section important in summarizing the results according to the demographic aspect. In section B, the questions consist 12 questions regarding teacher's organizational commitment adopted from [14]. While in Section C state the questions related to transformational leadership style of principals, which is consisting, 16 questions from MLQ (5X-short) adopted from [4]. Thus, in section D, the 12 questions of Emotional Intelligence adopted from Wong's Emotional Intelligence Scale [6].

4. Finding Result

4.1 Reliability, Normality and Validity

Sequentially, the next step is to examine the construct reliability and validity by using Composite Reliability (CR), Average Variance Extracted (AVE) and discriminant validity as shown in Table 1.

Table 1. Composite Reliability and Average Variance Extracted

Items	CR	AVE	Emotional Intelligence	Teacher's Organizational Commitment	Transformational Leadership Style
Emotional Intelligence	0.928	0.544	0.738		
Teacher's Organizational Commitment	0.934	0.587	0.476	0.766	
Transformational Leadership Style	0.947	0.561	0.536	0.586	0.749

Table 1 reported the results for CR and AVE, which are necessary, considered in CFA procedure. According to [13,35,36], the minimum acceptable value for CR and AVE is 0.70 and 0.50 respectively. In fact, the reliability and validity of a construct is proportionally related with the value of CR and AVE. In which a higher CR and AVE value indicate a higher reliability and validity for that construct. Specifically, the range value for CR is between 0.928 and 0.947, and the value for AVE for each construct reside between 0.544 and 0.587. Next, the assessment of normality was conducted to determine the construct correlation as shown in Table 2.

Table 2. Assessment of Normality

Variable	min	max	skew	c.r.	kurtosis	c.r.
C1	3.000	8.000	.044	.222	-.078	-.195
C2	3.000	8.000	.072	.358	-.108	-.271
C3	3.000	9.000	.300	1.502	.103	.257

Variable	min	max	skew	c.r.	kurtosis	c.r.
C4	4.000	9.000	.256	1.280	.399	.998
D12	2.000	7.000	-.016	-.082	.120	.300
C5	2.000	8.000	.200	.998	.809	2.024
C6	3.000	8.000	.033	.166	-.001	-.003
C8	3.000	7.000	.233	1.165	-.472	-1.179
C9	4.000	10.000	.299	1.493	.288	.719
C11	6.000	10.000	.066	.329	-.381	-.953
C12	2.000	7.000	.123	.617	-.153	-.382
C13	3.000	8.000	.156	.779	-.117	-.292
C14	4.000	8.000	.112	.562	-.249	-.623
C15	4.000	9.000	.247	1.237	.155	.388
C16	3.000	8.000	-.051	-.255	-.409	-1.024
D11	2.000	6.000	-.336	-1.679	-.352	-.881
D9	4.000	9.000	.065	.324	.177	.442
D8	2.000	7.000	-.056	-.281	-.060	-.150
D7	5.000	10.000	.140	.701	.087	.218
D6	2.000	9.000	-.061	-.305	.359	.898
D5	3.000	9.000	-.129	-.647	.829	2.073
D4	4.000	8.000	-.246	-1.231	-.520	-1.301
D3	4.000	9.000	.079	.395	-.329	-.823
D2	2.000	8.000	.023	.115	.254	.635
D1	2.000	8.000	-.133	-.665	.509	1.274
B11	3.000	8.000	.044	.220	-.349	-.872
B10	2.000	8.000	-.061	-.303	-.163	-.408
B9	3.000	9.000	.280	1.402	.627	1.568
B8	3.000	8.000	.082	.411	-.293	-.734
B7	2.000	7.000	-.151	-.755	-.218	-.546
B6	2.000	7.000	.066	.330	-.011	-.026
B4	3.000	9.000	.242	1.210	.280	.700
B3	3.000	9.000	.156	.781	.436	1.091
B2	3.000	9.000	.231	1.155	.550	1.375

Variable	min	max	skew	c.r.	kurtosis	c.r.
B1	3.000	8.000	-.041	-.203	-.162	-.406
Multivariate					2.800	.337

The normality assessment includes the analysis of skewness which have the rule of thumb of value between -1.5 to 1.5 [35,36]. Table 3 also presented the kurtosis test which is used to determine the normality pattern. According to [21], the minimum acceptable value for kurtosis is between -3.0 to 3.0. Based on the results reported above, all items were satisfied for parametric analysis such as SEM. And the latest prominent assessment of normality is the use of Multivariate of kurtosis which must be lesser than 50.0 [35,36]. The result indicated that Multivariate of kurtosis value is 2.800. Thus, the value achieved the requirement of lower than 50.0 value. In this study, confirmatory factor analysis (CFA) was led to test construct and convergent validity using the measurement model on SEM-AMOS. The model was finalized after achieving good fit according to some indicators.

Table 3. Confirmatory Factor Analysis (CFA)

Variables	Loading Factor	Chi-Square/df	RMSEA	CFI	TLI	IFI
TLS	0.81-0.88 > 0.6	1.604	0.064	0.963	0.957	0.963
EI	0.63-0.90 > 0.6	1.682	0.068	0.966	0.967	0.959
TOC	0.81-0.92 > 0.6	1.969	0.080	0.962	0.962	0.962

Figure 1 showed that the value of Chi-Square/df < 3 and other indicators also fit the recommended cut off values to fulfill the predict fit model and a test for CFA (RMSEA ≤ 0.08, AGFI ≥ 0.90, CFI ≥ 0.90, GFI ≥ 0.90, TLI ≥ 0.90). For CFA, the loading factor for each item reported based on standardized regression weight. None of the items with the values lower than 0.5. Therefore, the items achieved the accepted loading factors range from 0.63-0.92. It can be concluded that both construct and convergent validity accepted. In order to test the hypotheses, structural model was drawn with several indicators to achieve a good fit for the data. Final model shows that the significant Chi-square/df = 1.027. Other indicators also used to ensure the goodness of the fit model (RMSEA = 0.014, CFI = 0.995, IFI = 0.995, TLI = 0.995). The finding results show the reasonably the model fit with the data [12].

The results shown in Table 4 indicated that transformational leadership style has positive effect on teacher's organizational commitment ($\beta = 0.443$, CR= 4.786, $p = .000$), hence, H1 accepted. Transformational leadership style shows positive effect on emotional intelligence ($\beta = 0.525$, CR= 5.880, $p = .000$), therefore, H2 accepted. The findings also proved that emotional intelligence has positive effect on teacher's organizational commitment ($\beta = 0.222$, CR=2.555, $p = .001$), thus, H3 accepted.

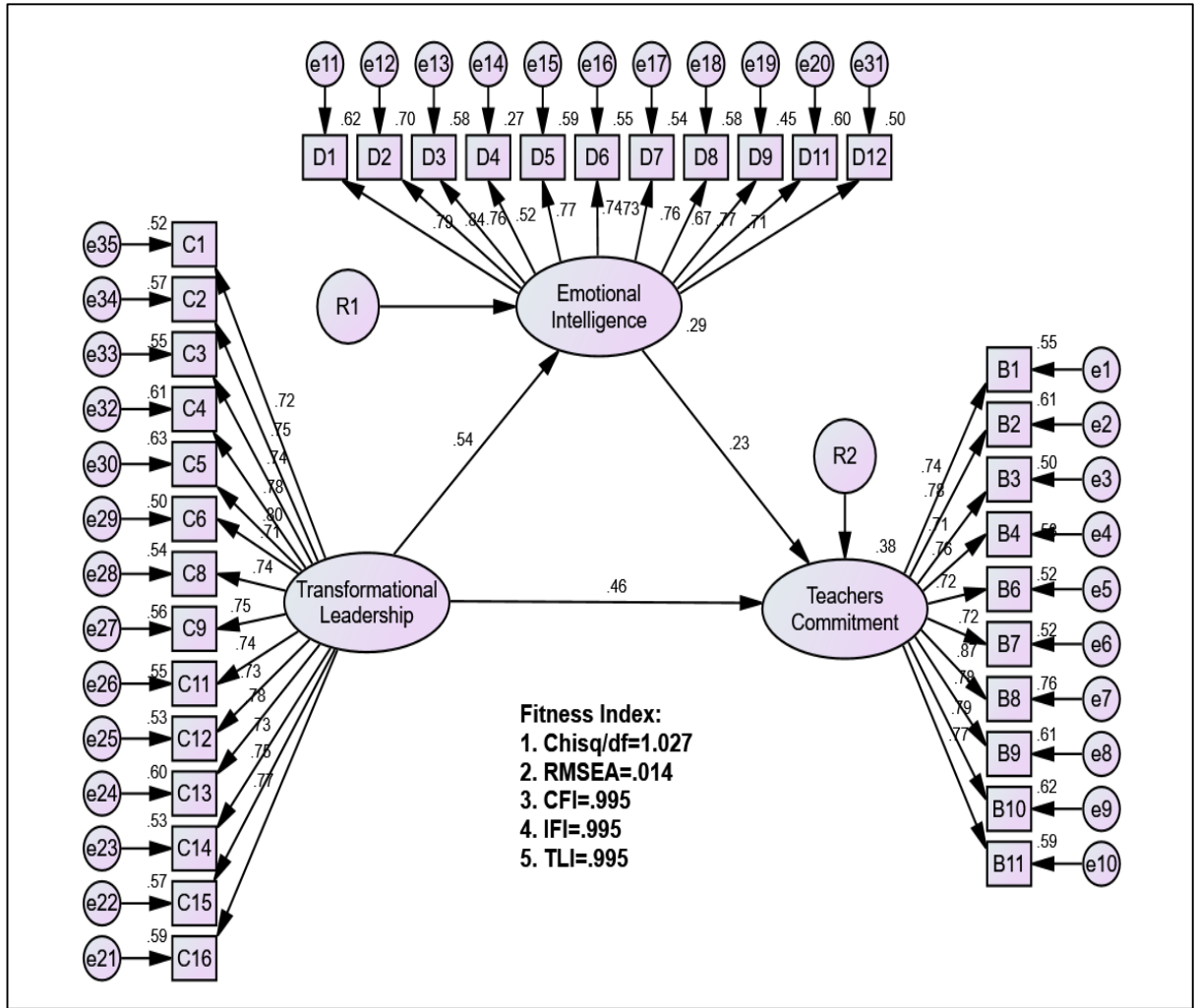

Figure 1. Structural Model

The results shown in Table 4 indicated that transformational leadership style has positive effect on teacher’s organizational commitment ($\beta= 0.443$, CR= 4.786, $p= .000$), hence, H1 accepted. Transformational leadership style shows positive effect on emotional intelligence ($\beta=0.525$, CR= 5.880, $p= .000$), therefore, H2 accepted. The findings also proved that emotional intelligence has positive effect on teacher’s organizational commitment ($\beta= 0.222$, CR=2.555, $p= .001$), thus, H3 accepted.

Table 4. Research Findings (Regression Weight)

Hypothesized Direct Effect	Estimate	S.E	C.R	P	Result
Teacher’s Organizational Commitment <--- Transformational Leadership Style	0.443	0.093	4.786	***	Significant
Emotional Intelligence <--- Transformational Leadership	0.525	0.089	5.880	***	Significant

Style					
Teacher's Organizational Commitment <--- Emotional Intelligence	0.222	0.087	2.555	0.011	Significant

Furthermore, to determine what type of mediation that Emotional Intelligence construct belongs to, the result for direct effect is examined. Table 5 showed the regression weight for direct effect is 0.464. The probability of getting bootstrap p-value for direct effect is 0.004 (p-value < 0.05). Along these lines, it can be concluded that the type of mediation for this model is **Partial Mediation** because the significant impact was found in the direct effect. The outcome from bootstrapping application is constant with Baron and Kenny approach.

Table 5: The result of Direct and Indirect Effect (Transformational Leadership Style, Emotional Intelligence, and Teacher's Organizational Commitment)

	Indirect Effect	Direct Effect
Bootstrapping Estimate	0.122	0.464
Bootstrapping P-Value	0.013	0.004
Result	Significant	Significant
Type of Mediation	Partial Mediation	

5. Discussion

This study examined the mediation effect of emotional intelligence between the relationship of transformational leadership style on teacher's organizational commitment among the daily secondary school teachers in Terengganu. The results revealed that form the H1, transformational leadership style had positive and significant effect on teacher's organizational commitment. This result was consistent with the findings of several previous studies [1,9,18,32]. This means that the transformational principals tend to enhance the level of teacher's commitment. They able to stimulate the working efficiency, be more considerable with teachers, influence new ideas, motivated the teachers become more confident. Next, for H2 the finding also proved that transformational leadership style shows positive and significant effect on emotional intelligence and it matched with several previous studies [5,17,28]. The educational implication from this finding was that those principals who practice transformational leadership style related with emotional intelligence. They lead the organization with their emotional intelligence. They able to control and aware their emotional intelligence before making any decision or react on any possible and impossible situations. From the H3, found that emotional intelligence shows positive and significant effect on teacher's organizational commitment. This finding was in line with previous studies [10,11,15,30,34]. This finding could be interpreted that principals with higher level of emotional intelligence can enhance the level of teacher's commitment in school. The school success comes from the committed teachers. They able to increase the level of students learning outcomes which can upgrade the victory for the schools. Finally, according to H4 the findings found that emotional intelligence mediates the relationship between transformational leadership style on teacher's organizational commitment.

6. Conclusion

It can be concluded that, transformational principals with higher level of emotional intelligence able to enhance the level of teacher's commitment in school. Found that the effect of emotional intelligence between the relationships of transformational leadership style on teacher's organizational commitment stronger via the indirect effect compared to direct effect without the emotional intelligence as a mediator. Future study need more studies is according to stress and cannot control the emotional intelligence. Therefore, teachers need a special policy for family takaful or life insurance to protect teachers 'mental health for them to be good teachers [22,23,23,24,25].

References

- [1] A. Aydin, Y. Sarier and S. Uysal, "The Effect of School Principals' Styles on Teachers Organizational Commitment and Job Satisfaction", *Educational Sciences: Theory & Practice*, vol 13, no. 2, (2013), pp. 806-811.
- [2] A. Hermawati and N. Mas, "Mediation effect of quality of worklife, job involvement, and organizational citizenship behavior in relationship between transglobal leadership to employee performance", *International Journal of Law and Management*. Vol. 29, no. 2, (2017), pp. 1143-1158.
- [3] A. Luo, P. Guchait, L. Lee, and J. Madera, "Transformational leadership and service recovery performance: The mediating effect of emotional labor and the influence of culture", *International Journal of Hospitality Management*, vol. 77, (2018), pp. 31-39.
- [4] B.M. Bass and B.J. Avolio, "MLQ: Multifactor Leadership Questionnaire", Mind Garden, Redwood City, (1995).
- [5] C. Koh, and E. O'Higgins, "Relationships between emotional intelligence, perceived and actual leadership effectiveness in the military context", *Military Psychology*, vol. 30, no. 1, (2018), pp. 27-42.
- [6] C.S. Wong and K.S Law, "The effects of leader and follower emotional intelligence on performance and attitude: An exploratory study", *The Leadership Quarterly*, vol. 13, no. 3, (2002), pp. 243-274.
- [7] E.A Locke, "Why emotional intelligence is an invalid concept", *Journal of Organizational Behavior*, vol. 26, no. 4, (2005), pp. 425-431.
- [8] H. Azamudin, Z. Mohamed, A. Amzairi & H. S. Zullina, "Emotional Intelligence as Mediator between Leadership Styles and Leadership Effectiveness: A Theoretical Framework", *International Review of Management and Marketing*, vol. 6, no. 1, (2016), pp. 116-121.
- [9] H. Hui, H. Salarzadeh Jenatabadi, B. Ismail, N. Azina, W.M. Radzi, and C.W. Jasimah, "Principal's leadership style and teacher job satisfaction: A case study in China", *Interdisciplinary Journal of Contemporary Research in Business*, vol. 5, no. 4, (2013), pp.175-184.
- [10] H.K. Chi, H.P Tsai and P.F. Chang, "Investigating the relationship among leadership styles, emotional intelligence and organization commitment on job performance: A study of salespeople in Thailand", *The Journal of Human Resource and Adult Learning*, vol 3, no. 2, (2007), pp. 199-212.
- [11] H. Tang, M. Yin, and D. Nelson, "The relationship between emotional intelligence and leadership practices : A cross-cultural study of academic leaders in Taiwan and the USA", *Journal of Managerial Psychology*, vol. 15, no.8, (2010), pp. 899-926.
- [12] J.F. Hair, W. Black, B. Babin, and R. Anderson, "Multivariate Data Analysis", 7th ed., Pearson New International Edition. New Jersey: Pearson/Prentice Hall, (2014).
- [13] J.F. Hair, G.T.M Hult, C.M. Ringle, and M. Sarstedt, "A Primer on Partial Least Squares Structural

- [14] J.P Meyer, and N. Allen, "A Three-Component Conceptualization of Organizational Commitment", *Human Resource Management Review*, vol. 1, no. 1, (1991), pp. 61-89.
- [15] L. Badea and N. Pană, "The Role of Empathy in Developing the Leader's Emotional Intelligence" *Theoretical and Applied Economics*, vol. 7, no. 2, (2010), pp. 69-78.
- [17] L. Gardner, and C. Stough, "Examining the relationship between leadership and emotional intelligence in senior level managers", *Leadership and Organizational Development Journal*, vol. 23, no. 2, (2002), pp. 68-78.
- [16] M. Asrar-ul-Haq, S. Anwar and H. Misbah, "Impact of emotional intelligence on teachers' performance in higher education institutions of Pakistan", *Future Business Journal*, vol. 3, no. 2, (2017), pp. 87-97.
- [17] M.A. Khan, "Organizational cynicism, motivation and employee turnover intention: Evidence from banking sector in Pakistan", *Journal of Commerce and Social Sciences*, vol. 8, no. 1, (2014), pp. 30-41.
- [18] N. Cemaloğlu, F. Sezgin and A. Catağay Kiliç, "Examining the Relationships between School Principals' Transformational and Transactional Leadership Styles and Teachers' Organizational Commitment", *The Online Journal of New Horizon in Education*, vol. 2, no. 2, (2012), pp. 53-64.
- [19] N.J. Allen and J.P. Meyer, "The measurement and antecedents of affective, continuance and normative commitment to the organization", *Journal of Occupational and Organizational Psychology*, vol. 63, no. 1, (1990), pp.1-18.
- [20] N.N.Z.B.A. Azhar, P.L.B. Ghazali, M.B. Mamat, Y.B. Abdullah, S.B. Mahmud, S.B. Lambak, Z.B. Sulong, N.H.B.M Foziah, A.Z.B.A Latif, "Acceptance of Integrated Modification Model of Auto Takaful Insurance in Malaysia", *Far East Journal of Mathematical Sciences*, vol. 101, no. 8, (2017), pp. 1771-1784.
- [21] P.B Lowry and J. Gaskin, "Partial Least Squares (PLS) Structural Equation Modeling (SEM) for Building and Testing Behavioral Causal Theory: When to Choose It and How to Use It", *IEEE Transactions on Professional Communication*, vol. 57, no. 2, (2014), pp. 123-146.
- [22] P.L. Ghazali, N.H.M. Foziah, M. Mamat, R.A Razak, L.B. Omar, A. Afthanorhan and W.M.N. Wan Daud, "Mathematical Concept in Integration Model of Education Plan Takaful", *International Journal of Recent Technology and Engineering*, vol. 7, no. 5, (2019), pp. 594-599.
- [23] P.L. Ghazali, M. Mamat, L.B. Omar, N.H.M. Foziah, D.A. Guci, Y.B. Abdullah and N.E.S.B Sazali, "Medical Integration Model of Family Takaful for Blue Collar", *Far East Journal of Mathematical Sciences*, vol. 101, no. 6, (2017), pp. 1197-1205.
- [24] P.L. Ghazali, N.M. Abu Bakar, I. M. Tahir, M. Haron, W.Z. Wan Ismail and M. Mamat, "Optimization of Integration Model in Family Takaful", *Applied Mathematical Sciences*, vol. 9, no. 37- 40, (2015), pp. 1899 - 1909.
- [25] P.L Ghazali, I. Mohd, W.M.A.W Ahmad and M. Mamat, "Implementation of Integration Model for All", *Journal of Applied Sciences Research*, vol. 8, no. 3, (2012a), pp. 1802-1812.
- [26] P.L Ghazali, I. Mohd, W.M.A.W Ahmad and M. Mamat, "Integration model of education plan Takaful: A case study for Terengganu, Kelantan and Perlis, states in Malaysia", *Far East Journal of Mathematical Sciences*, vol. 65, no. 1, (2012b), pp. 97-117.
- [27] P. Salovey, J. Mayer, "Emotional Intelligence", *Imagination, Cognition and Personality*, vol. 9, no.3, (1990), pp. 185-211.

- [28] R. R. Rehman and A. Waheed (2012), “Transformational Leadership Style as Predictor of Decision Making Styles: Moderating Role of Emotional Intelligence”, *Pak. J. Commer. Soc. Sci.*, vol. 6, no. 2, (2012) pp. 257- 268.
- [29] R. Tannenbaum, and W.H. Schmidt, “How to choose a leadership pattern”, *Harvard Business Review*, USA: Institute of industrial relations, (1958), pp. 95-101.
- [30] S. Gerhard Huber, “School leadership and leadership development: Adjusting leadership theories and development programs to values and the core purpose of school”, *Journal of Educational Administration*, vol. 42, no. 6, (2004), pp. 669-684.
- [31] S.L. Choi, C.F. Goh, M.B. Adam and O.K. Tan, “Transformational leadership, empowerment, and job satisfaction: the mediating role of employw empowerment”, *Human Resources for Health*, vol. 14, no. 1, (2016), pp. 73.
- [32] T. Calik, F. Sezgin, H. Kavgaci and A. Catagay Kilinc, “Examination of Relationships between Intructional Leadership of School Principals and Self-Efficacy of Teachers and Collective Teacher Efficacy”, *Educational Sciences: Theory and Practice*, vol. 12, no. 4, (2012), pp. 2498-2504.
- [33] V.J García-Morales, F.J. Lloréns-Montes and A.J. Verdú-Jover, “The effects of transformational leadership on organizational performance through knowledge and innovation”, *British Journal of Management*, vol. 19, no. 4, (2008), pp. 299-319.
- [34] Y. Hur, P.T. van den Berg, C.P. Wilderom, “Transformational leadership as a mediator between emotional intelligence and team outcomes”, *The Leadership Quarterly*, vol. 22, no. 4, (2011), pp. 591–603.
- [35] Z. Awang, A. Afthanorhan, M. Mohamad and I. Asri, “An Evaluation of Measurement Model for Medical Tourism Research: The Confirmatory Factor Analysis Approach”, *International Journal of Tourism Policy*, vol. 6 no. 1, (2015), pp. 29-45.
- [36] Z. Awang, “SEM Made Simple: A Gentle Approach to Learning Structural Equation Modeling”, MPWS Rich Publication. Bandar Baru Bangi. Malaysia, (2015).

Authors



Puspa Liza Ghazali is an Associate Professor in Faculty of Business and Management at the Universiti Sultan Zainal Abidin. Research interest in Statistical Modelling, Financial Mathematics, Insurance, Islamic Insurance, Teaching and Learning, and Mathematical Science.



Farah Wahida Jaafar is a master student in Management Science at Universiti Sultan Zainal Abidin. Her Research interest in teacher’s management in school, emotional intelligent among teachers and classroom management in pedagogy.



Asyraf Afthanorhan is a lecturer in Faculty of Business and Management at the Universiti Sultan Zainal Abidin. Research interest in Statistics, Statistical Modelling and Business Mathematics.



Eni Noreni Mohamad Zain is a lecturer in Faculty of Business and Entrepreneurship at the Universiti Malaysia Kelantan. Her research interest includes Financial Economics, Financial Mathematics, Business Mathematics and Statistics.



Roslida Abdul Razak is currently a lecturer at Faculty of Business and Management Sciences at Universiti Sultan Zainal Abidin (UniSZA), Malaysia.



Mustafa Mamat, is currently a Professor of Computational and Applied Mathematics at Universiti Sultan Zainal Abidin (UniSZA), Malaysia since 2013. He obtained his PhD from UMT in 2007 specialization in optimization field. To date, he has successfully supervised more than 80 postgraduate students with more than 300 journal papers. His research interest includes unconstrained optimization such as conjugate gradient methods and chaotic systems. Currently, he is the Editor in Chief for Malaysian Journal of Computing and Applied Mathematics (a UniSZA journal in applied science) and an editor for Indonesian Journal of Science and Technology.