



Business and Wealth Wellbeing: Towards Attaining Maqasid As-Syariah

PROCEEDING
3RD UUM INTERNATIONAL

Islamic Business Management Conference 2020
(IBMC2020)

24 – 30 SEPTEMBER 2020



**Proceedings
3rd UUM International Islamic Business
Management Conference 2020
(IBMC 2020)**

Hosted by:
**Islamic Business School,
Universiti Utara Malaysia,
Sintok, Kedah, Malaysia**

Date:
24 – 30 September 2020

Edited by:
**Assoc. Prof. Dr. Norazlina Abd. Wahab
Dr. Mohamad Yazid Isa**

Copyright© 2020 by Islamic Business School, UUM,
Kedah.
All rights reserved.

eISBN: 978-967-2276-25-8

**Islamic Business School
Level 1, Economics Building
Universiti Utara Malaysia
06010 Sintok, Kedah**

ACKNOWLEDGEMENT

First of all, I would like to thank all authors for submitting their papers for the Proceedings of International Conference on 3RD UUM International Islamic Business Management Conference 2020 (IBMC2020). This conference organized by Institute of Shariah Governance and Islamic Finance (ISGaIF), Islamic Business School (IBS) Universiti Utara Malaysia in collaboration with International Shariah Research Academy for Islamic Finance (ISRA). This conference aimed to expand UUM's role in international level as an eminent institution. It is also aimed at research organisations, universities, government agencies, policy-makers and corporate representatives from all over the world

The theme "Business and Wealth Wellbeing: Towards Attaining Maqasid As-Syariah" focuses on research related to Islamic business management. This conference took place from 24 to 30 September 2020 via online.

All papers were reviewed by both our local and international reviewers as listed in the cover page of this Proceeding.

We are also glad to inform that IBMC 2020 is currently collaborating with the following journals:

- i. Jurnal Ekonomi Malaysia (Scopus indexed journal)
- ii. ISRA International Journal of Islamic Finance (Scopus indexed journal)
- iii. International Journal of Management Studies (Refereed journal)
- iv. International Journal of Islamic Business (Refereed journal)
- v. Journal of Accounting Research, Organization and Economics (Refereed journal)
- vi. Al-Uqud Journal of Islamic economics (Refereed journal)

With the collaboration, selected papers from the Proceedings will also be published in one of the above journals.

Lastly, we would like to thank you to all presenters and participants for their invaluable contribution for the Proceedings and we look forward to be working with all of you again in our future conferences.

Norazlina

Chairman

ASSOC. PROF. DR. NORAZLINA ABD. WAHAB

IBMC 2020

TABLE OF CONTENT

No.	Authors	Title	Page
1	Mohd Azizi Ibrahim, Alias Mat Nor & Raja Rizal Iskandar Raja Hisham	Contractor Intention On Contractors All Risk Takaful Product In Malaysian Construction Industry	1
2	Mohamad Hanif Abu Hassan & Sofri Yahya	Determinants Of Repayment Behaviour In Islamic Microfinance Programs: Case Study Of The Rural Economy Funding Scheme	12
3	Maryam Jameelah Hashim, Nur Afizah Muhamad Arifin & Rahim Khamis	Role Of Intellectual Capital Components And Government Support On Islamic Microfinance Institution's Performance: A Study In Malaysia	32
4	Asikin Razak & Fuadah Johari	Al-Hajiyat Dalam Perlaksanaan Instrumen Al- Tawriq Untuk Pembangunan Aset Wakaf	43
5	Ahmad Aizuddin, H, Norhazlina, I. Amir Shaharuddin & Sumaiyah Abd Aziz	The Conceptualize Of Product Range With Sme Owner Preference On Islamic Sme Financing	49
6	Nuurul 'Afiah Mamad	Survival Strategies On Muslim Small And Medium Enterprise (Sme) During Covid-19: A Study On Tourism Industry In Malacca.	53
7	Wong Hua Siong	Embracing Islamic Concept Of Corporate Governance Of Whistle-Blowing In Malaysia	61
8	Saikou Gassama	Islamization Of Accounting Policy As A Solution To The Ethical Problem In Accounting.	76
9	Aisyah As Salafiyah, Muhammad Yusuf Ibrahim & Arip Rahman	Shariah Indicators For Shariah Wedding Organizer	80
10	Zainordin Zinon Abidin, Noraziah Che Arshad & Nor Jannah Ismail	Operational Specific Factors (Osf) That Impacted The Performance Of Family Takaful Operators In Malaysia.	89
11	Nor Jannah Ismail & Zainordin Zinon Abidin	The Awareness Towards Zakat Obligation Among University Students: A Study In Unimap	98
12	Shamsuddeen Muhammad Ahmad, Nur Farhah Mahadi & Nur Razinah Mohd Zain	Covid-19: Reinforcing The Impact Of Islamic Banking Through Value-Based Intermediation	110
13	Muhamad Fairos Mohamad Shah	Business Strategy Impact In Customer Relationship Management Performance Characteristic Among Smes Transport Service	114
14	Nainatul Farzuha Nor & Mohd Faizuddin Muhammad Zuki	Pensijilan Halal: Sejauh Manakah Organisasi Dalam Industri Halal Di Malaysia Menjamin Pematuhan Terhadap Piawaian Halal?	123
15	Mohamed Battour, Mohamed Salaheldeen & Khalid Mady	Halal Tourism: Marketing Opportunities for Halal Entrepreneurs	128
16	Saif Saeed Alyileili	The Impact Of Strategic Leadership On Achieving Job Satisfaction For Workers In The UAE Islamic Banking Sector	133
17	Andi Tamsang Andi Kele, Sharija Che Shaari, & Roseni Ariffin	Headscarf Ban On Malaysian Hotel Employees	139

18	Auna Najiah Ahmad, Mohd Ali Mohd Noor & Hairunnizam Wahid	Tahap Kefahaman Terhadap Konsep Kesederhanaan Dalam Penggunaan: Apakah Faktor Penentunya?	147
19	Oumaima Tounchibine, Nor Razinah Mohd Zain, Syed Marwan Syed Azman & Engku Rabiah Adawiah Engku Ali	Understanding Potentials Of Humanitarian Sukuk And Its Contribution Toward Financial Refugees Crisis	160
20	Syarifah Md Yusof, Azizah Othman, Raziah Md Tahir, Nor Aina Mhd Khotib, Emy Ezura A.Jalil & Nor Aina Mardhiah Nazim	Premis Makanan Industri Kecil Dan Sederhana Dalam Sektor Halal: Isu Dan Permasalahan	165
21	Mohd Faizuddin Muhammad Zuki	The Determinants Of Non-Financing Income: An Analysis On Islamic Banks In Malaysia	175
22	Mohd Afifie Mohd Alwi, Azwan Abdullah & Azyanee Luqman	Maqasid Al-Shariah In Debt Management: A Systematic Review	182
23	Mariana Jusop, Risyawati Mohamed Ismail & Noor Azizi Ismail	The Islamic Business Ethics In E-Commerce: Evidence From Malaysian Halal E-Marketplace	189
24	Sharija Che Shaari, Nik Ahmad Kamal Nik Mahmod & Farheen Baig Sardar Baig	Islamic Perspective Of The Malaysian Occupational Safety And Health (OSH) Legislation	195
25	Ahmad Azrin Adnan, Junainah Ahmad Esa & Mohamad Izzuddin Abdul Aziz	Punca Tekanan Kewangan Peribadi Di Malaysia: Satu Penelitian Fenomenologikal	204
26	Mohar Yusof, Mohd Yaziz Mohd Isa & Leilanie Mohd Nor	An Investigation Into The Development Of Family Waqf And Family Business Waqf In Malaysia	215
27	Mohd Fazrin, Mohd Yusof & Mohd Ghadafi	Pandangan Dan Pendapat Penggunaan Aplikasi Grabpay Oleh Pengusaha-Pengusaha Restoran Makanan Di Aeon Tebrau Dan Toppen Tebrau	223
28	Sharifah Rahama Amirul & Sharija Che Shaari	From The Lens Of Maqasid Al-Shariah: Attaining Quality Of Life Through Flexible Work	227
29	Azmawida Abdullah, Mohd Murshidi Mohd Noor & Syarifah Md Yusof	Niat Daripada Perspektif Islam Dalam Aktiviti Kepenggunaan	233
30	Shahida Shahimi, Azrina Abdullah Al-Hadi, Abd Ghafar Ismail & Nurul Wafa' Mohd Bohari	Measuring The Financial Inclusion: Evidence From OIC Countries	241
31	Nadiah Abdul Lateb, Syarifah Md Yusof & Nor Aina Mhd Khotib	The Concept Of Halalan Tayyiban From The Manual Procedure For Malaysia Halal Certification (Third Revision) 2014 (Mpphm 2014)	255
32	Moh'd Lawal Danrimi & Salisu Isyaku	Investors Herding Propensity In Islamic Financial Market: A Review	262
33	Mohamad Ali Roshidi Ahmad	The Causes And Implication For The Failure And Delayed In Muslims Inheritance Distribution	269

34	Azizah Othman, Syarifah Md Yusof, Raziah Md Tahir & Norashidah Hashim	Mekanisme Bantuan Zakat Dalam Membangunkan Pendidikan Anak-Anak Asnaf Di Kedah	278
35	Shahida Abd. Latif, Siti Hawa Mohd Yusoff, Yati Ashikin Abd Wahab, Hafizan Hashim & Hanita Hashim	Assessing Halal Awareness And Determinants Of Halal Purchasing Intentions Among Adolescents In Malaysia	284
36	Surajudeen Jolaosho	Service Quality And Pilgrims Experience: A Case Of Al Mahbuub Hajj And Umrah Services In Ogun State, Nigeria.	295
37	Zuhairah Ariff Abd Ghadas, Hartinie Abd Aziz & Nazri Ramli	The Legal Concept Of Corporation Under Common Law And Shariah: An Appraisal	306
38	Zuhairah Ariff Abd Ghadas, Nazri Ramli & Hartinie Abd Aziz	An Analysis On The Legal Concept Of Group Of Companies Under The Common Law And Shariah	316
39	Mohamad Nizam Jaafar, Amirul Afif Muhamat, Norzifah Abdul Karim & Wan Shah Shakhila-Shahar	The Effect Of Intellectual Capital On Financial Performance: Empirical Evidence From Shariah Compliant Construction Firms In Malaysia	324
40	Afef Khalil	Effects Of The Board Of Directors Characteristics On Islamic Banks Financial Soundness	334
41	Misbah Sadiq	The Impact Of Financial Measures, Earnings Management And Sukuk Structure On Sukuk Rating: Evidence From Pakistan.	344
42	Aminu Abdullahi & Alhassan Kawu Abubakar	Does The Triple Bottom Line Reporting Matters To Nigerian Stakeholders? A Literature Survey Approach	351
43	Adil Darwish Al Zaabi & Ali Ahmad Alkaabi	Business Risk Management In Islamic Institutions And Banks	358
44	Yahya Ahmed Saif Alsarhani	The Concept Of Intellectual Capital Within Banking Industry In Gcc	362
45	Akintan, I. & Dabiri, M	The Relevance Of Islamic Financing Instruments On Covid 19 Recession In Nigeria	372
46	Asiah Kamal, Ahmad Azam Sulaiman@Mohamad & Mohammad Taqiuddin Mohamad	Model Dana Tambahan Bagi Penawaran Takaful Mikro Kepada Warga Emas	385
47	Nur Afizah Muhamad Arifin, Noraini Mohd Arifin, Zulkufly Ramly & Maryam Jameelah Hashim	The Role Of Competition As A Mediator Between Financial Liberalization And Financial Stability: Islamic Banks Vs Conventional Banks	402
48	Norhazlina Ibrahim & Safeza Mohd Sopian	The Over Concentration Of Tawarruq Contract In Islamic Home Financing In Malaysia	408
49	Annisa Fitri Anugrah Sari	Optimization Of Mosque Financial Governance For The Planning Of Activities In Supporting The Economy Of Mosque In Indonesia	421
50	Nurul Akma Mohamed, Mujiburrahman Muhammad Saleh, Hamidi Abdul Ghani & Suraini Saufi	Isu Dan Cabaran Pelaksanaan Wakaf Dalam Membangunkan Ekonomi Ummah : Analisis Terhadap Sorotan Karya	426

51	Alaeddine Ziouache, Marina Abu Bakar & Mirzan Mohideen Bathusa	Shariah Issues In Sukuk Ijarah Mawsufah Fi Al-Zimmah	435
52	Lydiawaty Hassan Busry & Nurul Huda Abdul Majid	Waqf Education For Private Universities In Malaysia: Development And Prospects	449
53	Anita Ismail, Farah Laili Muda @ Ismail, Mashitah Sulaiman & Norhaziah Nawai	Sharia Compliant Of Crowdfunding Through The Financing Platforms In Small Medium Enterprises (Sme)	455
54	Zulfikar	The Impact Of Covid-19 On Islamic Banking In Indonesia During Pandemic Era	462
55	Syazwani Abd Rahim	Volatility Behaviour Of Sukuk Index During Crisis	473
56	Nur 'Izzah Mohamad Zahid & Noraziah Che Arshad	The Interaction Between Islamic Banking And Economic Growth:The Malaysian Experience	486
57	Siti Raihana Hamzah, Nur 'Arifah Ghazali & Karmila Hanim Kamil	Factor Analysis On Financial Ratios To Determine Financial Distress Of Islamic Banks In Malaysia.	492
58	Umni Syafiqah Nor Azman & Siti Hajar Salwa Ahmad Musadik	Why Do Some People Purchase Or Not To Purchase In A Shariah-Based Private Retirement Scheme (Prs)?	500
59	Mohd Murshidi Mohd Noor, Ahmad Khilmy Abdul Rahim & Afnan Faiz Ridzuan Ahmad	Peruntukan Dana Zakat Untuk Kes-Kes Di Luar Jangka Berdasarkan Perspektif Hadith Nabawi: Satu Analisis	510
60	Ahmad Khilmy Abdul Rahim, Azizi Abu Bakar, Mohd Murshidi Mohd Nor & Alias Mat Nor	The Innovations Of Hibah As An Instrument Of Islamic Finance And Islamic Estate Management In Malaysia	520
61	Muhammad Asyraf Mohd Kassim, Ahmad Bashir Aziz & Suhaila Abdul Hanan	Combating Road Accident Proneness Among Car Drivers In Malaysia: Perspectives From Maqasid Al-Shariah	528
62	Noor Syahirah Zakaria, Azizah Othman & Nor Ashikin Mohd Nor	Maqasid Shariah Applications As A Parameter For Muslim Tourism Package In Malaysia	436
63	Muhamad Fhadli Syakirin Mohd Jamalludin & Zairy Zainol	The Impact Of Islamic Banking And Fintech On Economic Growth: An Empirical Analysis	541
64	Raziah Md Tahir, Syarifah Md Yusof & Azizah Othman	Mekanisme Agihan Zakat Asnaf Al-Gharimin Dalam Kalangan Peserta Amanah Ikhtiar Malaysia Melalui Lembaga Zakat Negeri Kedah (Lznk)	552
65	Nashwan Taqiaddin, Esmail Al-Moshiki, Mohamed Battour & Muhammad Khairi	The Administrative Consequences Of Armed Conflict And Their Impact On Technical And Vocational Education And Training (Tvet (An Applied Study In Community Colleges In Yemen.	557
66	Moza Al Suwaidi	Assessing The UAE's Experience In Investing Endowments In Educational Aspects	574
67	Hussain Khalil Alsemsi	The Organizational And Practical Framework For The Internal Audit Function In The United Arab Emirates	579

68	Habeebullah Zakariyah & Ahmad Abdulla O M Al-Own	Using The Zakat Fund In Structuring Islamic Micro Takaful Model As An Alternative For The Existing Models	591
69	Aadel Mohammed Alshehhi	Take Advantage Of The Principles Of Strategic Planning In Islamic Thought To Activate Job Performance	601
70	Badr Alhosani	The Concept Of Innovation In Islam And The Methodology Of Its Administration In Contemporary Institutions	615
71	Khalid Said Awadh Fadhil	قطاع في المستدامة التتمية على القيادة الانمط تأثير عمان بسلطنة الكيمائية الصناعات	634
72	Sharifa Rashed Al Suwaidi	Judges Authority In Banking Disputes In Islamic Banks In The United Arab Emirates	675
73	Mohammad Golamur Rahman	The Social Solidarity And Its Role During Coronavirus	684
74	Mohamed Hamadikinane Maiga	The Basic Rules For Financial Transactions And Their Impact On Islamic Banking	690

CONTRACTOR INTENTION ON CONTRACTORS' ALL RISK *TAKAFUL* PRODUCT IN MALAYSIAN CONSTRUCTION INDUSTRY

Mohd Azizi Ibrahim, Alias Mat Nor & Raja Rizal Iskandar Raja Hisham

Islamic Business School, Universiti Utara Malaysia, Kedah, Malaysia

Abstract

Contractors' All Risks (CAR) *Takaful* is completely different from CAR conventional insurance. CAR conventional insurance involves elements of usury (*riba*), gambling (*maysir*) and uncertainty (*gharar*) in their resources and operations which is prohibited by *Shari'ah*. The objective of this paper is to investigate the relationship between attitude, awareness, understanding, religiosity, subjective norm, service quality and role of agents with contractor's intention in choosing CAR *Takaful* products based on theory of planned behaviour (TPB). In addition, this paper aims to address the most influential factors that affect contractor's intention in choosing CAR *Takaful* products. Using primary data collection method, 421 questionnaires were distributed to target respondents comprising of Bumiputera contractors in Malaysia except Sabah and Sarawak who are registered with CIDB from grade G1 to grade G7 and also a member of Persatuan Kontraktor Melayu Malaysia (PKMM). The data were analysed using Statistical Package for the Social Sciences (SPSS) software version 25. The results of this study reveal that there is a significant relationship between attitude, awareness, understanding, religiosity, subjective norm, service quality and role of agents with contractor's intention in choosing CAR *Takaful* products. This research also verifies that attitude is the most important factor that affects contractor's intention in choosing CAR *Takaful* products. The significance of this paper will definitely bring great benefits to the *Takaful* operators and *Takaful* agents in Malaysia to formulate additional strategies, policies and service quality to attract Bumiputera contractors to choose CAR *Takaful* product.

Keywords: CAR *Takaful*, attitude, awareness, understanding, religiosity, subjective norm, service quality and role of agents.

1. INTRODUCTION

Among the most popular and all-inclusive insurance policies cover used in construction contracts is Contractors' All Risks (CAR) (Perera *et al.*, 2008). CAR insurance policy is a short-term insurance policy, which insures the works in a construction contract. CAR insurance policy is specially designed to cover engineering projects involving both constructions of the building and other civil engineering works that are being carried out. CAR insurance policy provides coverage against any unforeseen and sudden physical loss or damage from any cause, other than those specifically excluded. CAR insurance policy is designed to provide cover for all the parties involved in a construction project, hence, the policy is usually acquired in the joint names of the client or the principal agent and the contractor (Musundire & Aigbavboa, 2015).

However, an alternative to the CAR insurance is the *Shari'ah* compliant insurance otherwise known as CAR *Takaful*. CAR *Takaful* Policy is *Shari'ah* compliant and will ensure that their work is always protected against losses or damages incurred on construction sites during the construction period. This cover also includes third party liabilities such as bodily injuries and property damage related to building and contract work (Zulkifli *et al.*, 2012; Mohd Fauzi & Abd Rashid, 2012).

According to the Construction Industry Development Board Malaysia (CIDB), as at the end 2018, the total numbers of contractors registered from grade G1 to grade G7 throughout Peninsular Malaysia are 70,586. Of these, 36,204 are Bumiputera contractors, representing 51.29 per cent of the total contractors. Non-Bumiputera contractors are free to choose between Islamic or conventional products. But now, with the advancement of *Takaful* providing alternative to conventional insurances that conceptually follow Islamic teachings and to obeying the commands of Allah in the way of the Qur'an, it has become a mandatory requirement for every Bumiputera contractors in Malaysia to choose CAR *Takaful* products.

Nevertheless, a study conducted by Mohd Fauzi *et al.* (2016) found that contractors' understanding of CAR *Takaful* was still low. More surprisingly, the contractor was also not aware of the concepts and principles of *Takaful* itself. In addition, same study by Mohd Fauzi and Abd Rashid (2012) found that 31 per cent of the Muslim contractors have no experience in procuring CAR *Takaful* for construction works contract even though in a country where Bumiputera contractors are predominantly Muslim. Respondents also have never dealt with CAR *Takaful* products and have never taken CAR *Takaful* products in construction contracts.

To date, there are 15 *Takaful* operators licensed by the Bank Negara Malaysia. Out of these, four (4) *Takaful* operators are registered as General *Takaful* operators including 7,123 registered as General *Takaful* agents (MTA, 2019). However, Mohamed and Alhabshi (2015) revealed the penetration rate of *Takaful* is still quite low compared to the conventional insurance market and lag far behind. The problem is 50 per cent of the respondents have not been approached by any *Takaful* agents, while religiosity has play significant factor as majority of the respondents do not plan to have *Takaful* policies as they opine that *Takaful* is not permissible being similar to conventional insurance (*haram*). In addition, The Malaysian Reserve, 3rd April 2017 also reported that until 2017, *Takaful* penetration rate is still low at 5.2 per cent of the gross domestic product (GDP). *Takaful* products have a net contribution of RM 6.3 billion or 13 per cent of the market share, while the conventional insurance segment recorded RM 42.5 billion.

Moreover, Mohd Fauzi *et al.* (2016) highlighted that based on reports released by Bank Negara Malaysia in 2014, contribution income for CAR *Takaful* stood lower than CAR conventional insurance at RM 107.2 million only in years 2014 million compared to CAR conventional insurance at RM 472.1 million. These statistics indicate that poor participation by Bumiputera contractors on *Takaful* CAR products has affected *Takaful*'s overall contribution income. This statement is also supported by Mohd Fauzi and Abd Rashid (2012) which found that only 69 per cent of the Muslim contractors have an experience in procuring CAR *Takaful* for construction works contract and six (6) per cent of respondents will consider only if the cost will not give implication to the insured.

Based on the previous research, there are many studies which related to *Takaful* such as Mansor *et al.* (2015); Abd Aziz *et al.* (2015); Md Hussin and Ab Rahman (2016); Md Hussin *et al.* (2016); Muhamad *et al.* (2016); Hassan *et al.* (2018) and Aziz *et al.* (2018). For example, Mansor *et al.* (2015) investigates the causal relationship between consumer awareness, perception and religiosity towards Muslim's consumer preferences on *Takaful* product. Abd Aziz *et al.* (2015) study about factors influencing the paddy farmers' intention to participate in agriculture *Takaful*. Md. Husin and Ab. Rahman (2016) studied on consumer intention to participate in *Takaful*. Meanwhile, Md Husin *et al.* (2016) had identified subjective norm, word of mouth and the roles of mass media factors in intention to purchase family *Takaful*. Muhamad *et al.* (2016) had examined the perceptions and awareness of *Takaful* among Muslims in Kelantan. Additionally, Hassan *et al.* (2018) had tested knowledge and awareness of *Takaful* among consumers in Malaysia. Aziz *et al.* (2018) studied about factors that influence individuals' intentions to purchase family *Takaful*. However, these studies have not been empirically verified on CAR *Takaful* in construction industry in Malaysia except Mohd Fauzi *et al.* (2016) and Mohd Fauzi and Abd Rashid (2012).

Therefore, this study applies the theory of planned behaviour (TPB) and several important variables will be tested such as attitude, awareness, understanding, religiosity, subjective norm, service quality and role of agents toward contractor's intention in choosing CAR *Takaful* products. The researcher wants to fill the gap by distributed questionnaires to the Bumiputera contractors' grade G1 to grade G7 who are registered with CIDB and also a member of Persatuan Kontraktor Melayu Malaysia (PKMM). This scope of study covers all regions in Malaysia except Sabah and Sarawak.

2. LITERATURE REVIEW AND HYPOTHESES DEVELOPMENT

2.1 Attitude

Fishbein and Ajzen (1975) have provided insights into the impact of assessing individuals' positive or negative feelings on certain behaviours. Various studies have confirmed the importance of attitudes toward behavioural intention. Chang (2006) suggested consumers' attitudes, however, depend on the attributes and the benefits.

Ab. Rahim and Amin (2011) investigated the factors that influence *Takaful* acceptance among Malaysian bank customers in Labuan. The results of the multiple regression analysis showed that attitude was found to have a significant effect on *Takaful* acceptance. In addition, a study done by Md Husin and Ab Rahman (2016) in the Klang Valley found that attitude directly and significantly influenced consumers' intention to participate in the *Takaful* scheme. They suggested that consumers with a high positive attitude toward the family *Takaful* scheme will be particularly interested in participating and subsequently develop an intention to participate.

Moreover, Aziz *et al.* (2018) investigated factors that influence individual intention to purchase family *Takaful* and found that attitude was positively related to purchase intention regarding family *Takaful*. This means that a positive attitude to purchase family *Takaful* scheme will lead to positive purchase intentions.

2.2 Awareness

Words of awareness mean the passive involvement of an individual and can raise interest in certain issues (Bickford & Reynolds, 2002). Awareness is a key factor in developing a subjective idea of one's experience in relation to something (Nizam, 2006). According to Ambali and Bakar (2014), different people have different level of awareness about something. It is important for the consumers to know about the product that is offered to them because awareness reflects the individual satisfaction associated with the product from problems that may arise due to less information (Taylor, 2005).

Mohd Fauzi and Abd Rashid (2012) examine the contractors understanding and application of CAR *Takaful* in the Malaysian construction industry. The results found that all of the respondents claimed that they are aware of CAR *Takaful* in general. In other areas of *Takaful* study, Hassan *et al.* (2018) examine the knowledge and awareness of *Takaful* among Malaysian consumers. The findings show that out of the 503 respondents, 378 or 75.2 per cent of them are aware of *Takaful*.

In addition, Muhamad *et al.* (2016) also investigates about Muslims perception and awareness towards *Takaful* in Kelantan. The findings show that Muslim perceptions and awareness in Kelantan are modest. Female respondents were found to have greater awareness and understanding of *Takaful*. Furthermore, Ayinde and Echchabi (2012) studied on Malaysian customers' willingness to adopt *Takaful* services and factors that may influence their behaviour. These findings indicate that Malaysian customers are ready to use the *Takaful* service and the outcome depends on two factors i.e. compatibility and awareness.

In another field of study, Erol and El-Bdour (1989) point out that the awareness of Islamic bank customers with knowledge of Islamic banking is greatly influenced by its relatives and neighbours in Jordan. Haron *et al.* (1994) conducted research among Muslim and non-Muslim customers. They found that 63 per cent of respondents knew the difference between Islamic and conventional banking.

2.3 Understanding

Mohd Fauzi and Abd Rashid (2012) conducted research on contractors who are registered under grade G7 with the CIDB in Wilayah Persekutuan Kuala Lumpur and Selangor. The findings indicate the respondents' understanding on the concept of CAR *Takaful* is deficit as majority of the respondents do not understand on the concepts of *Takaful* itself. Respondents provided justification that they do not understand at all about the prohibited elements by *Shari'ah* in conventional insurance and each is lacking in understanding of the benefits of CAR *Takaful* product.

Similarly, Abdul Hamid and Othman (2009) test the understanding and awareness of Muslims in Malaysia regarding *Shari'ah* terms used in *Takaful*. They found that respondents' understanding of *Takaful* was still low as 67.24 per cent of respondents did not know about *tabarru'* which is the main feature and essence of *Takaful*. Most respondents did not understand the concept of *Takaful* itself.

Matsawali *et al.* (2012) examined the public preferences and understanding between *Takaful* and conventional insurance. It is found that a big majority of the respondents do not understand what *Takaful* is. According to Kamil and Mat Nor (2014), the respondents got knowledge and understanding about *Takaful* through reading or through internet and promotion given by *Takaful* agents only.

In another field of study, Haron *et al.* (1994) in one of the pioneering studies on bank patronage in Malaysia found that most respondents would like to have a relationship with an Islamic bank if they have a complete understanding of the Islamic banking system. Additionally, Bassir *et al.* (2014) have concluded that the use of Islamic home financing is determined by the high level of understanding among Muslims.

2.4 Religiosity

Johnson *et al.* (2001) defined religiosity as the extent to which an individual is committed to a religion, and he admitted to his teachings, such as attitudes and individual behaviour reflects that commitment. According to Bergan and McConatha (2000), religiosity refers to various dimensions associated with religious beliefs and

involvement. Holdcroft (2006) defined the term religiosity as the notion of individuals' actions that may be influenced by the extent of their religious knowledge and beliefs. Meanwhile King and Williams (2005) defined religiosity as the strength of one's connection to or conviction for their religion. One's connection is like a bond to the religion and conviction for their religion means belief in their religion.

Mohd Fauzi and Abd Rashid (2012) found that 91 per cent of the respondents will consider procuring CAR *Takaful* as the insurance for construction works because CAR *Takaful* is an Islamic product, so it should be supported by all the Muslims. They added that CAR *Takaful* provides more benefits and profits. Thus, it should be the best insurance product to be procured by a company. It is supported by Mansor *et al.* (2015) indicated that religiosity play a significant influence towards preferences in *Takaful* product. This means that Muslim consumers of higher religiosity tend to have higher priority over *Takaful*.

Furthermore, Hassan and Abbas (2019) investigate factors influencing the investors' intention to adopt *Takaful* products. Using a sample of 345 individuals amongst Pakistani people, they found that religiosity mostly considered critical and effective factor to effect at *Takaful* adoption. This shows that religiosity is also a very important factor in a religious country like Pakistan and it affects the *Takaful* adoption very effectively.

In another field of study conducted by Haron *et al.* (1994) found that Muslim customers believe that if they make investment in the *Shari'ah* compliance investment, they will get blessing from *Allah* in the future. Muslim consumers are preferred to choose Islamic banking products compared to conventional products. The main role of Muslims is religious obligation that influences the individual behaviour to choose the activities that are not contradict the *Shari'ah*.

2.5 Subjective Norm

Subjective norm is defined as a person's perception of the people most important to him that people should or should not do to his behaviour and motivation to comply with particular reference (Ajzen & Fishbein, 1980). Subjective norms refer to the individual's perception of social pressure around him in performing or not performing a certain behaviour. This matter is determined by the normative belief that assesses social pressures on the individual's particular behaviour (Ajzen, 1991).

Eagly *et al.* (1993) gives the meaning of the subjective norm as the individual's perception of whether the other person is important to translate the idea of an individual in behaviour that must be done. It is also classified as peer pressure. It refers to whether the person who participates or intends to participate in such behaviour is strongly influenced by those around them or not. These people may include partners or friends, family, colleagues, community leaders and other notable people.

Abdul Razak *et al.* (2018) investigated micro entrepreneurs' behaviour towards their participation in micro-*Takaful* and found that subjective norm factor had a direct and significant influence on the tendency on micro-takaful participation. This finding indicated that the greater the influence from others, the more likely that micro-entrepreneurs would participate in the schemes mentioned. In addition, Md Husin and Ab Rahman (2016b) collected data from 384 Muslim consumers in Kuala Lumpur, Malaysia, using a convenience sampling approach. The result revealed that subjective norm has significant effect on intentions to purchase a family *Takaful* scheme and indicates that subjective norm plays an important role in influencing consumer intention to purchase a family *Takaful* scheme. They suggested, the more positive the subjective norm, the more likely that consumer will purchase a family *Takaful* scheme.

2.6 Service Quality

Parasuraman *et al.* (1985) defined service quality as a function of the difference between expectations and performance across the quality dimensions. Therefore, the issue of service quality refers to customer expectations of the service and their perception of how the service has been provided. According to Shin and Kim (2008), service quality is the effect of consumer service efficiency and it is strongly related to customer satisfaction. Moreover, the quality of the service is often considered as the effect of customer superiority or inferiority of the service provider and its services (Tsoukatos & Rand 2006).

In order to compete among each other, providing high level of service quality is very crucial for service providers (Yoo & Park, 2007; Bharati & Berg, 2005; Kemp, 2005). Service quality creates a competitive advantage and allows the company to distinguish itself from the competitors by attracting more consumers and increasing

company market share (Huseyin *et al.*, 2005). Service quality is important because, as the customer may switch to another service if they are not satisfied (Ryals & Knox, 2001).

Kashif *et al.* (2017) examined service quality on customer loyalty in the context of *Takaful* sector in Pakistan. They found that service quality is strongly correlated with customer satisfaction, trust and customer loyalty. Md Razak *et al.* (2013) investigated the factors that influence the acceptance towards *Takaful* among people in Malaysia. They also found that the most dominant factor influencing *Takaful* customer acceptance was the quality of service.

In addition, Mohd Shaladdin *et al.* (2018) was conducted a research on 210 respondents from Universiti Sultan Zainal Abidin (UniSZA) and Universiti Malaysia Terengganu (UMT) including both staff (lecturers and administrative staff) and students (undergraduates and postgraduates). The finding indicates that high quality service will positively enhance customer satisfaction in *Takaful* Insurance services and further making *Takaful* remain competitive in the market.

2.7 Role of Agents

Takaful agents have become one of the leading channels in the *Takaful* industry to market *Takaful* products to the public. In addition to promoting *Takaful* products, agents must practice Islamic ethics in helping customers and play an important role in recognizing *Takaful* as an alternative to conventional insurance (Samsuri & Jamal, 2017). Agents are responsible for assisting their customers in all matters related to their financial well-being and disseminating information about *Takaful* to the public (IBFIM, 2011).

Hui-Chen (2006) claimed that a vital role in developing relationship among the buyer and seller is portrayed by the agents. While, Kamil and Mat Nor (2014) indicated the important of *Takaful* agents in explaining the concept of *Takaful* can influences the choice of *Takaful* and promotes customer satisfaction. The agent's role is considered as an aspect of *Ibadah* and the obligation in promoting the *Takaful* product to Muslims is being attributed as *Da'wah*. It has been self-evident in this study where respondents stated that one of the factors that led them to purchase *Takaful* products was the agent.

Mohd Salleh *et al.* (2013) provide evidence that there is a significant positive relationship between Islamic ethics practices by *Takaful* agents regarding *Takaful* products. *Takaful* operators should play their part in guiding and encouraging their agents to adopt Islamic ethics in order to attract customers to choose their *Takaful* scheme. Mohd Shaladdin *et al.* (2018) proved that the role of agents has a positive relationship for *Takaful* services. *Takaful* agents act as the leader representing the firm to serve the customers.

METHODOLOGY

3.1 Theoretical Framework

In this study, modifications have been made on TPB which was developed by Ajzen (1991). In the field of CAR *Takaful*, this study considers the TPB models that explain the factors in determining the contractor's intention in choosing CAR *Takaful* products. Figure 1 shows the framework of the TPB applied to this study.

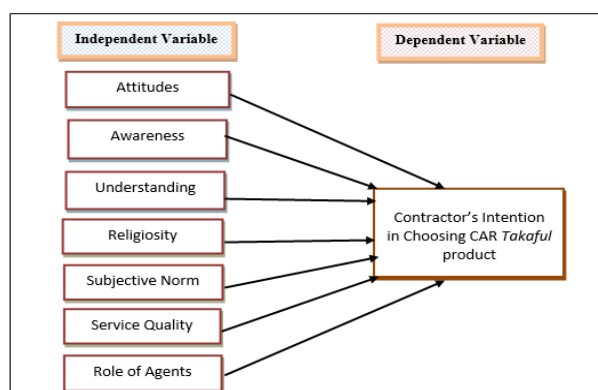

Figure 1: Theoretical Framework of the Study

Referring to the literature review and theoretical framework, this study developed the following hypothesis:

- H1 : There is a significant relationship between attitude and contractor's intention in choosing CAR *Takaful* products.
- H2 : There is a significant relationship between awareness and contractor's intention in choosing CAR *Takaful* products.
- H3 : There is a significant relationship between understanding and contractor's intention in choosing CAR *Takaful* products.
- H4 : There is a significant relationship between religiosity and contractor's intention in choosing CAR *Takaful* products.
- H5 : There is a significant relationship between subjective norm and contractor's intention in choosing CAR *Takaful* products.
- H6 : There is a significant relationship between service quality and contractor's intention in choosing CAR *Takaful* products.
- H7 : There is a significant relationship between role of agents and contractor's intention in choosing CAR *Takaful* products.
- H8 : There is a significant affect of the factors of attitude, awareness, understanding, religiosity, subjective norm, service quality and role of agents on contractor's intention in choosing CAR *Takaful* products.

3.2 Sample, Procedure, and Instruments

This study only focuses on Bumiputera contractors who are registered in grade G1 to grade G7 with CIDB and also a member of PKMM. This scope of study covers all regions in Malaysia except Sabah and Sarawak. On the other hand, PKMM is an NGO organization in which members consist of Malay contractors who have a 100 per cent Malay or Bumiputera registered with the CIDB from grade G1 to grade G7 throughout Malaysia. According to CIDB (2019), at the end 2018, the total number of Bumiputera contractors registered in all grades, namely grade G1 to grade G7 throughout Malaysia except Sabah and Sarawak are 36,204.

In this study, researchers used proportionate stratified sampling. The main advantage of using proportionate stratified sampling include representativeness with respect to variables used as the basis of classifying categories and increased chances of being able to make comparisons between strata (Singh, 2006). In other words, the use of this method is to increase accuracy without incurring costs. Therefore, for this research, by referring to Krejcie and Morgan (1970), the researcher has personally distributed 760 sets of questionnaires to the respective respondents which is Bumiputera contractors registered with CIDB in all grades, namely grade G1 to grade G7 and also a member of PKMM in Malaysia except Sabah and Sarawak. 471 questionnaires were returned by the respondents. Only 421 completed and can be used for data analysis which about 55.39 per cent of response rate.

The dependent variable in this study is contractor's intention in choosing CAR *Takaful* products. Meanwhile, the independent variables are attitude, awareness, understanding, religiosity, subjective norm, service quality and role of agents. These variables are adopted from the previous research and have been validated by the authors. In addition, the questionnaires consist of eight variables. The items in the questionnaire is adapted from more than single authors. Variable of intention adapted from Aziz *et al.* (2018), Nor and Pearson (2008) and Taylor and Todd (1995). In addition, four (4) variables which are attitude, awareness, understanding and subjective norm adapted from Aziz *et al.* (2018), Md Husin *et al.* (2016), Md Husin and Ab Rahman (2016), Soualhi and Al Shammaari (2015), Amin *et al.* (2014) and Amin *et al.* (2013). Meanwhile variable of religiosity adapted from Aziz *et al.* (2018), Bassir *et al.* (2014) and Alam *et al.* (2012). Additionally, two (2) variables, service quality and role of agents adapted from Mohd Shaladdin *et al.* (2018) and Kumar (2010). The operational definition refers to the items of questions that used in the survey. Measurement variables in this study were adopted from previously validated instruments.

3.3 Data Analysis

The raw data obtained in this study will be analyzed using several statistical tools. The statistical tools and interpretation of the results in quantitative data analysis will be using the Statistical Package for the Social Sciences (SPSS) software version 25. It aims to test the influence of independent variables on the contractor's intention in choosing CAR *Takaful* products. In this study, descriptive statistical analysis methods, reliability test, correlation analysis and multiple regression analysis were used to analyse the collected data. The data later were analysed and the hypothesis is tested.

Descriptive statistical is the transformation data into a format that will make it easy for researchers to understand and interpret. It was a common method of organizing, summarizing and presenting the variable (Zikmund, 2003).

Descriptive analysis was conducted to summarize the information about the population or sample in this study. It transformed raw data into a set of information in describing a set of factors in a situation. Descriptive analysis presented the mean score and standard deviation of the data collected. According to Hair *et al.* (2006), the spread or variability of the sample values from the mean will be explained by the standard deviation. If the value of the standard deviation is small, so, the reaction in a sample distribution of number will be fall very close to the mean.

To test for the reliability, Cronbach's Alpha was used. The most common measure of scale reliability is equivalent to Cronbach's Alpha. Cronbach's Alpha is indicated the reliability coefficient and how the items correlated to the one another (Sekaran, 2003). Cronbach's Alpha can be explained as a correlation coefficient that ranges from 0 to 1. The closer the coefficient to 1 is the better the result (Sekaran, 2003). Reliabilities ranging from 0.50 to 0.60 are sufficient for exploratory studies (Nunnally, 1978), in the range of 0.70 are acceptable and over 0.80 are good (Sekaran, 2003). The values of Cronbach's Alpha closer to 1 ensure the higher internal consistency reliability.

Pearson correlation is an important statistical method that measures the strengths among the variables and the relationships between those involved variables (Hair *et al.* 2009). Correlation analysis in this research is to detect the relationship between the independent variables and the dependent variable. Moreover, this analysis is used to test Hypothesis H₁, Hypothesis H₂, Hypothesis H₃, Hypothesis H₄, Hypothesis H₅, Hypothesis H₆ and Hypothesis H₇ studied in this research. According Veal (2005), if the value of the Pears on correlation coefficient (r) showed a positive (+) 1.0, so there is a positive correlation between the two variables. If the negative (-) 1.0 then there is a negative correlation between the two variables. While the correlation coefficient indicates zero then there is no relationship between two variables. If the correlation coefficient indicates between 0 and 1.0, there are some positive correlation coefficient is positive or between 0 and negative (-) 1.0 showed a negative relationship between two variables.

Multiple regression analysis was carried out to determine the affect of independent variables on dependent variable. In addition, this analysis also helps in understanding the extent to which the variance in the dependent variable explained by the independent variables. Therefore, it gives explanation significant on affects between seven (7) factors i.e. attitude, awareness, understanding, religiosity, subjective norm, service quality and role of agents with contractor's intention in choosing CAR *Takaful* products.

4. FINDING AND ANALYSIS

4.1 Reliability Test

The position of the reliability test for each construct in this study reported in Table 1. Reliability is measured by using Cronbach's Alpha (Churchill, 1979). There are eight (8) constructs was tested in the reliability test which were of intention, attitude, awareness, understanding, religiosity, subjective norm, service quality and role of agents. The result 0.80 and above are considered good, those in the range 0.70 was acceptable and those below than 0.60 was considered as poor (Cavana *et al.*, 2001). In this study, the results for all constructs are situated in the range of 0.752 and 0.984. Therefore, the result of this study can be considered good and acceptable.

Table 1: Reliability Analysis

Variables	No. of Item	Cronbach's Alpha
Intention	7	0.983
Attitude	8	0.974
Awareness	6	0.955
Understanding	6	0.752
Religiosity	8	0.984
Subjective Norm	7	0.952
Service Quality	8	0.939
Role of Agents	7	0.918

4.2 Pearson Correlation Analysis

Correlation analysis was used to assess the strengths and the relationship between two variables. This analysis is also used to test the hypothesis that has been formulated to make a conclusion whether to accept or reject the hypothesis. Researcher will use the Pearson correlation analysis to test Hypothesis H₁, Hypothesis H₂, Hypothesis H₃, Hypothesis H₄, Hypothesis H₅, Hypothesis H₆ and Hypothesis H₇ whether the hypothesis is significantly

correlated with the dependent variable, namely contractor's intention in choosing CAR *Takaful* products or vice versa.

The results in the present study showed that the Pearson correlation coefficient (r) have a positive and significant relationship between independent variables of intention, attitude, awareness, understanding, religiosity, subjective norm, service quality and role of agents with the dependent variable, contractor's intention in choosing CAR *Takaful* products. The star (**) sign shows that there is a significant relationship at the confidence level of 99 per cent (** $p < 0.01$). Therefore, Hypothesis H₁, Hypothesis H₂, Hypothesis H₃, Hypothesis H₄, Hypothesis H₅, Hypothesis H₆ and Hypothesis H₇ are accepted.

Table 2: The Pearson Correlation Coefficient between Independent Variables and the Dependent Variable

		Intention	Attitude	Awareness	Understanding	Religiosity	Subjective Norm	Service Quality	Role of Agents
Intention	Pearson Correlation	1	.860**	.824**	.436**	.806**	.456**	.698**	.666**
	Sig. (2-tailed)		.000	.000	.000	.000	.000	.000	.000
	N	421	421	421	421	421	421	421	421
Attitude	Pearson Correlation	.860**	1	.911**	.453**	.848**	.458**	.746**	.693**
	Sig. (2-tailed)	.000		.000	.000	.000	.000	.000	.000
	N	421	421	421	421	421	421	421	421
Awareness	Pearson Correlation	.824**	.911**	1	.514**	.890**	.513**	.841**	.783**
	Sig. (2-tailed)	.000	.000		.000	.000	.000	.000	.000
	N	421	421	421	421	421	421	421	421
Understanding	Pearson Correlation	.436**	.453**	.514**	1	.513**	.270**	.444**	.433**
	Sig. (2-tailed)	.000	.000	.000		.000	.000	.000	.000
	N	421	421	421	421	421	421	421	421
Religiosity	Pearson Correlation	.806**	.848**	.890**	.513**	1	.408**	.738**	.705**
	Sig. (2-tailed)	.000	.000	.000	.000		.000	.000	.000
	N	421	421	421	421	421	421	421	421
Subjective Norm	Pearson Correlation	.456**	.458**	.513**	.270**	.408**	1	.525**	.443**
	Sig. (2-tailed)	.000	.000	.000	.000	.000		.000	.000
	N	421	421	421	421	421	421	421	421
Service Quality	Pearson Correlation	.698**	.746**	.841**	.444**	.738**	.525**	1	.876**
	Sig. (2-tailed)	.000	.000	.000	.000	.000	.000		.000
	N	421	421	421	421	421	421	421	421
Role of Agents	Pearson Correlation	.666**	.693**	.783**	.433**	.705**	.443**	.876**	1
	Sig. (2-tailed)	.000	.000	.000	.000	.000	.000	.000	
	N	421	421	421	421	421	421	421	421

** . Correlation is significant at the 0.01 level (2-tailed).

4.3 Multiple Regressions Analysis

Multiple regression analysis was applied in this study to examine the factor affecting contractor's intention in choosing CAR *Takaful* products and also to proof Hypothesis H₈. Table 3 presents the results of the analysis of multiple regressions. The result from multiple regression showed that R square was 0.767; adjusted R square was 0.763 and the F-Ratio was 194.058. R square in this result tells the variation in the independent variables accounted for 76.7 per cent of variance in the dependent variable. In other words, it portrays about 76.7 per cent of the variance in compliance intention behaviour on CAR *Takaful* products was significantly explained by the variable

of intention, attitude, awareness, understanding, religiosity, subjective norm, service quality and role of agents. However, another 23.3 per cent can be explained by other variables.

Regression model reaches statistically significant as the p value is less than 0.01. Based on the analysis, attitude shows a significant affect on contractor's intention in choosing CAR *Takaful* products ($\beta=0.597, p<0.01$). Same result with religiosity which shows a significant affect on contractor's intention in choosing CAR *Takaful* products ($\beta=0.250, p<0.01$). In contrast, there is no significant affect between awareness ($\beta=-0.030, p=0.718$), understanding ($\beta=0.007, p=0.814$), subjective norm ($\beta=0.067, p=0.020$), service quality ($\beta=-0.017, p=0.768$) and role of agents ($\beta=-0.082, p=0.104$) on contractor's intention in choosing CAR *Takaful* products..

The standardized coefficients for variable in this present study were 0.597(attitude), -0.030 (awareness), 0.007(understanding), 0.520(religiosity), 0.67(subjective norm), -0.296(service quality) and 0.082(role of agents) respectively. According to the finding, attitude scored the highest beta value among the seven (7) independent variables at 0.597. Therefore, in this study, the most influential factors that affect the contractor's intention in choosing CAR *Takaful* products fall under the attitude.

This study confirmed that attitude is the most important factor that affect contractor's intention in choosing CAR *Takaful* products. This result reinforces earlier studies carried out by Aziz *et al.* (2018), Md Husin and Ab Rahman (2016) and Ab. Rahim and Amin (2011) where attitude appears to be the strongest determinant for adopting CAR *Takaful* products.

Table 3: Multiple Regression Analysis

	Unstandardized Coefficients		Standardized	t	Sig.	
	B	Std. Error	Coefficients Beta			
1	(Constant)	-1.418	1.512	-.937	.349	
	Attitude	.583	.058	.597	10.091	.000
	Awareness	-.037	.102	-.030	-.362	.718
	Understanding	.014	.058	.007	.236	.814
	Religiosity	.218	.047	.250	4.609	.000
	Subjective Norm	.084	.036	.067	2.340	.020
	Service Quality	-.025	.084	-.017	-.296	.768
	Role of Agents	.134	.082	.082	1.632	.104

a. Dependent Variable: Intention

Note:

$p<0.01$ (significant), $R^2 = 0.767$, $Adjusted R^2 = 0.763$, F statistic = 194.058, Sig. = 0.000

5.0 CONCLUSION AND RECOMMENDATION

This study shows that variables of attitude, awareness, understanding, religiosity, subjective norm, service quality and role of agents play an important role in affecting on the contractor's intention in choosing CAR *Takaful* products. The results of this study reveal that there is a significant relationship between attitude, awareness, understanding, religiosity, subjective norm, service quality and role of agents with contractor's intention in choosing CAR *Takaful* products. The results also verify that attitude is the most important factor that affects contractor's intention in choosing CAR *Takaful* products. These findings can contribute the knowledge and increase awareness to the Bumiputera contractors in Malaysia about the importance of choosing CAR *Takaful* products. The model theory that was developed in this study can be used as model information to the researchers who will come to measure knowledge in other fields. Therefore, the current study has provided some of the implications and provides valuable benefits to the academic and the practitioners of *Takaful* based on a review of the work done by the researcher.

These results can definitely bring great benefits to the *Takaful* operators in Malaysia towards developing and expanding their future business in the *Takaful* industry. In other words, by knowing the factors that affects the contractor's intention in choosing CAR *Takaful* products, *Takaful* operators may use these findings to formulate additional strategies, policies and service quality to attract Bumiputera contractors to accept and select CAR *Takaful* product. *Takaful* operators can understand the needs of Bumiputera contractors by providing services that meet their needs. Because CAR *Takaful* product is an alternative to CAR conventional insurance, it is important for *Takaful* operators to have the right information to meet the contractor's requirements. These findings also will help *Takaful* operators to evaluate and modify the design of current marketing strategies in a competitive

environment and in a more effective manner to increase their market share. The growth of *Takaful* operators in Malaysia can definitely become one of the choices of investment to the community in today world.

The researcher suggests to *Takaful* agents in Malaysia to develop strategies for promotional activities. Promotions not only need to be aggressive but also need to be consistent. All statistically significant variables can help *Takaful* agents better understand the influence of variables and the decision-making process underlying their insurance options. Therefore, *Takaful* agents must understand their customers better in order to influence and determine contractor behaviour and then educate Bumiputera contractors further to understand the mechanisms and benefits of CAR *Takaful*. Besides that, the results of this research are believed to serve as guidelines for *Takaful* agents to plan and implement approaches or methods that are of particular interest to Bumiputera contractors. Agent attitudes can drive greater market penetration and thus contribute to the development of the nation through the demand and trust of the agent's transparency and sincerity.

REFERENCES

- Abd Aziz, N.A., Abd Aziz, N.N, Wan Aris, Y.B. & Abd Aziz, N.A. (2015). Factors influencing the paddy farmers' intention to participate in agriculture *Takaful*. *Procedia Economics and Finance*, 31, 237-242.
- Abdul Hamid, M. & Othman, M.S. (2009). A Study on the Level of Knowledge and Understanding Among Muslims Towards the Concepts, Arabic and *Shari'ah* Terms in Islamic Insurance (*Takaful*). *European Journal of Social Sciences*, 10(3), 468-478.
- Abdul Razak, A., Muhammad, F., Hussin, M. Y. M., Ramdan, M. R., & Hadi, F. S. A. (2018). Applying Ajzen's Theory of Planned Behaviour on the Participation of Micro-Entrepreneurs in Micro-Takaful. *International Journal of Academic Research in Business and Social Sciences*, 8(11), 1666-1679.
- Aziz, S., Md Husin, M., Hussin, N. & Afaq, Z. (2018). Factors that influence individuals' intentions to purchase family *Takaful* mediating role of perceived trust. *Asia Pacific Journal of Marketing and Logistics*, 31(1), 81-104.
- Ajzen, I. & Fishbein, M. (1980). *Understanding Attitudes and Predicting Social Behavior*. Prentice-Hall, Englewood Cliffs, New Jersey.
- Ajzen, I. (1991). Theory of Planned Behavior. *Organization Behavior and Human Decision Process*. (50), 179-211.
- Alam, S.S., Janor, H., Zanariah, Che Wel, C.A. & Ahsan. M.N. (2012). Is religiosity an important factor in influencing the intention to undertake Islamic home financing in Klang Valley? *World Applied Sciences Journal*, 19(7), 1030-1041.
- Ambali, A.R. & Bakar, A.N. (2014). People's awareness on halal foods and products: Potential issues for policy-makers. *Procedia-Social and Behavioral Sciences*, 121, 3-25.
- Amin, H., Abdul Rahman, A.R. & Abdul Razak, D. (2014). Consumer acceptance of Islamic home financing. *International Journal of Housing Markets and Analysis*, 7(3), 307-332.
- Amin, H., Abdul Rahman, A.R. & Abdul Razak, D. (2013). An Integrative Approach for Understanding Islamic Home Financing Adoption in Malaysia. *International Journal of Bank Marketing*, 31(7), 544-573.
- Ayinde, L.O. & Echchabi, A. (2012). Perception and adoption of Islamic insurance in Malaysia: An empirical study. *World Applied Sciences Journal*, 20(3), 407-415.
- Bassir, N.F., Zakaria, Z., Hasan, H.A. & Alfian, E. (2014). Factors Influencing the Adoption of Islamic Home Financing in Malaysia. *Transformations in Business & Economics*, 13(1), 155-174.
- Bergan, A. & McConatha, J. T. (2000). Religiosity and life satisfaction. *Activities, Adaptation and Aging*, 24(3), 23-34.
- Bharati, P. & Berg, D. (2005). Service quality from the other side: Information systems management at Duquesne light. *International Journal of Information Management*, 25(4), 367-380.
- Bickford, D.M. & Reynolds, N. (2002). Activism and service-learning: reframing volunteerism as acts of dissent pedagogy. *Critical Approaches to Teaching Literature, Language, Composition and Culture*, 8(2), 229-252.
- Cavana, R. Y., Delahaye, B.L. & Sekaran, U. (2001). *Applied Business Research: Qualitative and Quantitative Methods*. John Wiley & Sons, Queensland.
- Chang, H. (2006). Integrating the role of sales agent into the branding model in the insurance industry. *The Journal of American Academy of Business*, 8(2), 278-28.
- Churchill, G.A. Jr. (1979). A Paradigm for Developing Better Measures of Marketing Constructs. *Journal of Marketing Research*, 16(1), 64-73.
- Eagly, A.H. & Chaiken, S. (1993). *The Psychology of Attitude*. Harcourt Brace Jovanovich, Forth Worth, TX.
- Erol, C. & El-Bdour, R. (1989). Attitude, Behaviour and Patronage Factors of Bank Customers towards Islamic Banks. *International Journal of Bank Marketing*, 7(6), 31-37.
- Fishbein, M. & Ajzen, I. (1975). *Belief, Attitude, Intention, and Behavior: An Introduction to Theory and Research*, Reading, MA, Addison-Wesley.
- Hassan, R., Salman, S. A., Kassim, S., & Majdi, H. (2018). Awareness and Knowledge of *Takaful* in Malaysia: A Survey of Malaysian Consumers. *International Journal of Business and Social Science*, 9(11), 45-53.
- Hair, J.F., Tatham, R.L., Anderson, R.E. & Black, W.C. (2006). *Multivariate data analysis (6th ed.)*. Prentice Hall, New York.
- Hair, J.F., Black, W.C., Babin, B.J. & Anderson, R.E. (2009). *Multivariate Data Analysis*. Upper Saddle River: Prentice Hall.
- Haron, S., Ahmad, N. & Planisek, S.L. (1994). Bank Patronage Factors of Muslim and non-Muslim Customers. *International Journal of Bank Marketing*, 12(1), 32-40.
- Hassan, H. A., & Abbas, S. K. (2019). Factors influencing the investors' intention to adopt *Takaful* (Islamic insurance) products. *Journal of Islamic Marketing*, 11(1), 1-13.
- Holdcroft, B. (2006). What is religiosity? *Catholic Education: A Journal of inquiry and practice*, 10(1), 89-103.
- Hui-Chen, C. (2006). Integrating the role of sales agent into the branding model in the insurance industry. *Journal of American Academy of Business, Cambridge*. 8(2), 278-285.
- Huseyin, A., Salih, T.K., & Salime, M.S. (2005). A comparison of service quality in the banking industry: Some evidence from Turkish- and Greek-speaking areas in Cyprus. *International Journal of Bank Marketing*, 23(7), 508-526.
- IBFIM (2011). *Buku Panduan Asas Takaful*. Islamic Banking and Finance Institute Malaysia Sdn. Bhd, Kuala Lumpur, Malaysia.
- Johnson, B.R., Jang, S.J., Larson, D.B. & Li, S.D. (2001). Does Adolescent Religious Commitment Matter? A Reexamination of the Effects of Religiosity on Delinquency. *Journal of Research in Crime and Delinquency*, 38(1), 22- 43.
- Kamil, N.M. & Mat Nor, N. (2014). Factors Influencing the Choice of *Takaful* Over Conventional Insurance: The Case of Malaysia. *Journal of Islamic Finance*, 3(2), 001-014.

- Kashif, M.T., Anjum, A., Ashfaq, M., Azeem, M., & Khurshid, M.K (2017). Assessing the Relationship between Service Quality and Customer Loyalty: Evidence from *Takaful* Insurance Customers in Pakistan. *Journal of Managerial Sciences*, 11(3), 335-360.
- Kemp, A. H. (2005). Getting what you paid for: Quality of service and wireless connection to the Internet. *International Journal of Information Management*, 25(2), 107-115.
- King, J.E. & Williamson, I.O. (2005). Workplace religious expression, religiosity and job satisfaction: Clarifying a relationship. *Journal of Management, Spirituality & Religion*, 2(2), 173-198.
- Krejcie, R.V. & Morgan, D.W. (1970). Determining Sample Size for Research Activities. *Educational and Psychological Measurement*, 30, 607-610.
- Kumar, R. (2010). Performance evaluation of General Insurance Companies: a study of post-reform period. Retrieved from <https://shodhganga.inflibnet.ac.in/handle/10603/2352>.
- Malaysian Takaful Association (2019). *Annual Report 2019*.
- Mansor, K.A., Masduki, R.M.N., Mohamad, M., Zulkarnain, N. & Aziz, N.A. (2015). A study on factors influencing Muslim's consumers' preferences towards *Takaful* products in Malaysia. *Romanian Statistical Review*, 2, 78-89.
- Matsawali, M.S., Abdullah, M.F., Chui Ping, Y., Abidin S.Y.M., Zaini, M. M. & Ali, H. (2012). A Study on *Takaful* and Conventional Insurance Preferences: The Case of Brunei. *International Journal of Business and Social Science*, 3(22), 163-176.
- Md Husin, M. & Ab Rahman, A. (2016). Do Muslims intend to participate in Islamic insurance? Analysis from theory of planned behaviour. *Journal of Islamic Accounting and Business Research*, 7(1), 42-58.
- Md Husin, M. & Ab Rahman, A. (2016b). Predicting intention to participate in family takaful scheme using decomposed theory of planned behaviour. *International Journal of Social Economics*, 43(12), 1351-1366
- Md Husin, M., Ismail, N. & Ab Rahman, A. (2016). The roles of mass media, word of mouth and subjective norm in family takaful purchase intention. *Journal of Islamic Marketing*, 7(1), 59-73.
- Md Razak, M.L., Idris, R., Yusof, M.M., Jaapar, W.E., & Ali, M.N. (2013). Acceptance Determinants toward *Takaful* Products in Malaysia. *International Journal of Humanities and Social Science*, 3(17), 243-252.
- Mohamed, O. E. B., & Alhabshi, D. D. S. O. (2015). Low Market Penetration of Takāful Among Malaysians: Non-Takāful Customers' Perspective. *International Journal of Ethics in Social Sciences*, 3(1), 5-22
- Mohd Fauzi, P.N.F.N. & Abd Rashid, K. (2012, December). The understanding of *Takaful* among the contractors of the Malaysian construction industry. *Management in Construction Research Association (MiCRA) Postgraduate Conference*. Kuala Lumpur.
- Mohd Fauzi, P.N.F.N., Abd Rashid, K., Sharkawi, A.A., Hasan, S.F., Aripin, S. & Arifin, M.A. (2016). *Takaful*: A review on performance, issues and challenges in Malaysia. *Journal of Scientific Research and Development*, 3(4), 71-76.
- Mohd Salleh, M.C., Abdullah, N.I. & Razali, S.S (2013). The Relationship of *Takaful* Agents' Islamic Ethical Behaviour towards Customers' Satisfaction, Trust and Commitment: A Preliminary Analysis. *Journal of Islamic Finance and Business Research*, 2(1), 77-88.
- Mohd Shaladdin, Z.F., Mokhtar, M.Z., Muhammad Zawawi, N.H (2018). Determinants of Customer Satisfaction in *Takaful* (Islamic Insurance) Services in Malaysia. *Jurnal Pengurusan*, 54(2018), 1-12.
- Muhamad, S.F., Abdullah, N.A., Abdul Aziz, N.A. & Azmi, N.F. (2016). The perception and awareness on *Takaful*: A descriptive analysis between the gender. *Intercontinental Journal of Marketing Research Review*, 4(10), 58-63.
- Musundire, S. & Aigbavboa, C. (2015). Management of construction risk through Contractor's All Risk insurance policy : a South Africa case study. *5th International/11th Construction Specialty Conference*. Vancouver, British Columbia, 1-8.
- Nizam, A. A. (2006). *Perception and awareness among food manufacturers and marketers on halal food in the Klang Valley*. Published Master Dissertation, Universiti Putra Malaysia.
- Nor, K.M. & Pearson, J.M. (2008). An exploratory study into the adoption of internet banking in a developing country: Malaysia. *Journal of Internet Commerce*, 7(1), 29-73.
- Nunnally, J.C. (1978). *Psychometric Theory* (2nd ed.). McGraw-Hill, New York.
- Parasuraman, A., Zeithaml, V.A., & Berry, L. L. (1985). A Conceptual Model of Service Quality and its Implication for Future Research. *Journal of Marketing*, 49(1), 41-50.
- Perera, B A K S, Rathnayake, R M C K and Rameezdeen, R (2008). Use of insurance in managing construction risks: Evaluation of Contractors' All Risks (CAR) insurance policy. *Built-Environment - Sri Lanka*, 8(2), 24-3.
- Ryals, L. & Knox, S. 2001. Cross-functional issues in the implementation of relationship marketing through customer relationship management. *European Management Journal*, 19(5): 534-542.
- Samsuri, M.A.Z.A & Jamal, J. (2017). *Takaful* Agent Must Foster Public Understanding of Takaful. *Diponegoro Law Review*, 2(2), 245-258.
- Sekaran, U. (2003). *Research Methods for Business: A Skill Building Approach* (4th ed.). John Wiley & Sons, Inc, New York.
- Shin, D. H., & Kim, W. Y. (2008). Forecasting customer switching intention in mobile service: An exploratory study of predictive factors in mobile number portability. *Technological Forecasting & Social Change*, 75(6), 854-874.
- Singh, Y.K (2006). *Fundamental of Research Methodology and Statistic*. New Age International (P) Ltd., Publishers, New Delhi.
- Soualhi, Y. & Al Shammari, A.A.R. (2015). Indicators of Takāful Awareness among Kuwaitis. *Journal of Islamic Banking and Finance*, 3(2), 75-89.
- Taylor, J.R. (2005). Customer satisfaction rises, but privacy concerns remain. *Region Focus*, 9(2), 9.
- Taylor, S. and Todd, P. (1995), Understanding Information Technology Usage: A Test of Competing Models. *Information Systems Research*, 6(2), 144-176.
- The Malaysian Reserve (3rd April 2017). Takaful Penetration Rate Still Low at 5.2%. Viewed on 24th September 2019. Retrieved from <https://themalaysianreserve.com/2017/04/03/takaful-penetration-rate-still-low-at-5-2/>
- Tsoukatos, E., & Rand, K. (2006). Path analysis of perceived service quality, satisfaction and loyalty in Greek insurance. *Managing Service Quality*, 16(5), 501-519
- Veal, A.J. (2005). *Business Research Method: a Managerial Approach* (2nd ed.). Pearson Education Australia, Australia.
- Yoo, D. K., & Park, J. A. (2007). Perceived service quality: Analyzing relationships among employees, customers, and financial performance. *International Journal of Quality & Reliability Management*, 24(9), 908-926
- Zikmund, W.G. (2003). *Business Research Method* (7th ed.). Thompson, United States of America.
- Zulkifli, A.M., Abd Rahman B.H., Yassin, N. & Ramly, J. (2012). *Basic Takaful Practices: Entry Level for Practitioners*. IBFIM, Kuala Lumpur.
- CIDB (2019). Retrieved from <http://cimsapp.cidb.gov.my/SMIS/regcontractor/reglocalsearchcontractor.vbhtml>

DETERMINANTS OF REPAYMENT BEHAVIOUR IN ISLAMIC MICROFINANCE PROGRAMS: CASE STUDY OF THE RURAL ECONOMY FUNDING SCHEME

Mohamad Hanif Abu Hassan & Sofri Yahya

University of Science, Malaysia

ABSTRACT

This study is primarily concerned with borrower behaviour in the context of microfinance financing repayment by exploring the antecedents of accountability as the mediator. The high non-performing loans (NPLs) incurred by micro finance institutions is one of the contributing factors for the failure in achieving the goal of poverty reduction. Bank Rakyat and SME Bank were selected as a sample due to the higher NPL percentages recorded. This study used the quantitative approach and structured questionnaires were distributed among respondents in Peninsular Malaysia who were selected via multistage random sampling. The results of the analysis showed that borrowers' repayment behaviour was affected by their characteristics and accountability. Moreover, religiosity and business performance did not have a significant direct relationship with repayment behaviour. This research also found that accountability played a significant positive role as a mediator between borrower characteristics (financial strength, religiosity, understanding contract, and business performance) and repayment behaviour. This study makes a significant contribution to the knowledge of microfinance programme, in which it explains repayment performance plays an important role in order to improve the social economy and alleviate poverty. The result of also contributed to the practical aspect by suggesting to improve service and screening approach to identify early warning signs and some factors that are potentially related to borrower behaviour.

Keywords: Islamic finance, microcredit, repayment, entrepreneurship.

1. INTRODUCTION

The motivation of the study arises out of concern for the repayment behaviour among the microfinance borrowers. As know, microfinance refers to the provision of financial service concentrating on the very poor, who often are from the low income group and self-employed (Idama, 2014; Otero, 1999). Sinha (1998) defined microcredit as small loans, whereas microfinance involves the provision of financial services by non-governmental organisations (NGOs) and micro finance institutions (MFIs), which include financing, saving, insurance, and other financial dealings. Thus, microcredit is a subset of microfinance, as microfinance encompasses the provision of credit financing for the low income group as well as non-credit financial products including savings, insurance, pensions, and payment services (Idama, 2014).

Even though the main purpose of microfinance is poverty alleviation, previous research works have documented mixed results regarding its effectiveness in reducing poverty. They found divergent findings, namely positive, negative, and no impact on poverty alleviation (Samer et al., 2015). Therefore, various factors have been investigated to explain the phenomenon, such as risk management, collaterals, performance issues, payment delinquency, and challenges. The high non-performance loans (NPLs) faced by micro finance institutions (MFIs) has been found as one of the factors that contributes to the failure of microfinance in achieving its main objective, which is to reduce poverty (Shu-Teng et al., 2015). In fact, poor loan collection in major rural credit schemes has caused heavy losses (Bichanga & Aseyo, 2013). The prevalence of NPLs in Malaysia has shown an increasing trend over the years (Chong et al., 2010; Nawai, 2013; Nawai & Shariff, 2012; Shu-Teng et al., 2015b).

In addition, according to Maiangwa (2012), individual-based lending is riskier as compared to group-based lending with regard to repayment performance. One of the documented risks is the ability to make payment because usually the amount of financing offered for individual-based lending is higher than for group-based lending. In addition, Maiangwa (2012) and Shu-Teng et al. (2015) stated that individual-based lendings are exposed to the deficiency of loan information and the problem of loan monitoring by financial institutions.

Furthermore, the previous studies have criticised the subsidised microfinance system¹, which recorded high default rates (Morduch, 2006; Robinson, 2001). This statement has been confirmed by Suraya Hanim Mokhtar, Zealand, and Gan (2012), who documented that repayment performance in several MFIs in Malaysia, especially under the subsidised system, have not been satisfactory. Thus, to illustrate this argument, some of the data from previous studies have been used to compare the repayment performance rates of microfinance facilities in Malaysia (refer to Table 1).

Table 1: The Prevalence of Non-Performing Loans/Financing (NPL/NPF) for Microfinance Products in Malaysia

FINANCIAL INSTITUTIONS	RATE OF NON-PERFORMANCE LOANS (NPL)	PRODUCT/FACILITIES APPROACH	SYARIAH COMPLIANCE
Government Agencies			
TEKUN Nasional	37.82%	Subsidiary	NO
Yayasan Usahawan Malaysia (YUM)	9.28%	Subsidiary	NO
Amanah Ikhtiar Malaysia (AIM)	1.5%	Subsidiary	NO
Permodalan Usahawan Nasional Berhad (PUNB)	6.35%	Subsidiary	NO
Cooperative Commission of Malaysia (CCM)	13.8%	Subsidiary	NO
Government Linked Companies (GLC)			
Perbadanan Nasional Berhad (PNB)	1.76%	Subsidiary	NO
Bank Rakyat	49%	Subsidiary	YES
SME Bank	12.3%	Subsidiary	MIXED
Commercial Banks			
Public Bank, CIMB, Maybank	Between 0.95%–3.15%	Own facilities	NO

Sources: (Bank Rakyat, 2015; Berita Harian, 2018; Bernama, 2018; KKLW, 2018; PNB, 2018; Shu-Teng et al., 2015a; Sun, 2018; suraya Hanim Mokhtar & Gan, 2012)

Table 1 shows the prevalence of loans defaults for the three main categories of microfinancing providers in Malaysia, namely government agencies, government-linked companies (GLCs), and commercial banks from 2012 to 2018. The government agencies, which are the Cooperative Commission of Malaysia (CCM), Permodalan Usahawan Nasional Berhad (PUNB) and Amanah Ikhtiar Malaysia recorded NPLs of 13.8%, 6.35 and 1.5% respectively. The higher percentages of NPLs were reported by TEKUN Nasional and Yayasan Usahawan Malaysia (YUM) stood with 37.82% and 9.28% respectively. Meanwhile, the commercial banks, namely Public Bank Berhad, CIMB Bank Berhad, and Malayan Banking Berhad (Maybank) recorded NPLs in the range of 0.95% to 3.15%. Under the GLC category, Bank Rakyat recorded higher NPL of 49% and following by SME bank which are stood with 12.3% in 2018. This percentage is worse than the percentages recorded by the government agencies and commercial banks. Based on NPL's percentage, the concern on this study more to emphasize on financial institution under the GLC due to recorded higher percentage and involved with subsidiary system. Therefore, the selection of Bank Rakyat and SME Bank as a sample for this study is expected to reveal more significant findings in relation to the causes of the NPL problems as compared to other institutions.

Moreover, the World Bank Group (2017) reported that Malaysian financial institutions had recorded the highest debts in the world. In 2014, 56% of Malaysian adults had bank loans, which was the highest percentage recorded worldwide (World Bank Group, 2017). Apart from that, Malaysia's NPL ratio had increased in September 2017 to 1.7% from 1.6% in 2016 (CEIC, 2017; World Bank Group, 2017). Among the reasons for the increase in NPL are weak global growth and economic reforms in the domestic economy such as the rationalisation of subsidies as well as the implementation of minimum wage and sales and services tax (SST) (Shaharudin et al., 2016; Wong & Eng, 2018). According to Shaharudin, Basri, and Isa (2016) and Zhou et al., (2014), the introduction of GST on 1 April 2015, SST and depreciation of the Ringgit have resulted in an increase in the cost of living, leading to adjustments in household spending. These circumstances were determined as factors that influence payment behaviour among the customers. Lastly, in year 2019 the trend of NPL was recorded increased with NPL ratio at 1.53% in January 2019 compared with 1.61% in July 2019. Increased the NPL percentage will reflecting the health

¹ Oxford Dictionary (2017) defines a subsidised system as the government or organisations supporting business activities or financially, while Mokhtar (2011) mentioned that under a subsidised system, the regulations or conditions of the loan are set by the government to ensure that the activities are run smoothly and efficiently.

of banking system and effect the loan cycle. Besides, difficulties to collecting it will affect the profit or interest and principal on the loan. The statistic of NPL performance as follow:

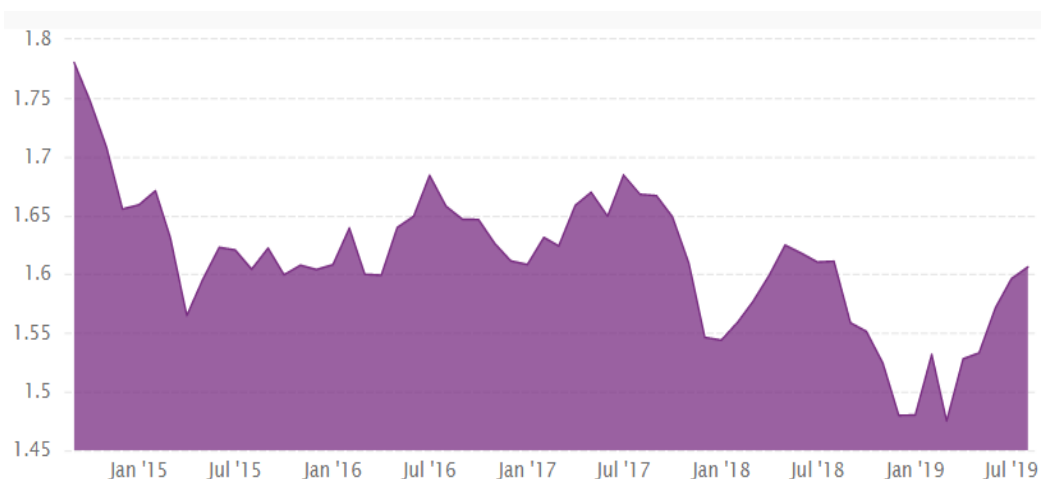

Sources: (CEIC, 2019)

Figure 1: Statistics of Non-Performing Loan (NPL)

Therefore, the factors of higher percentage of NPL, the implementation of additional tax, higher debt, subsidiaries problem, unstable Malaysia currency and shrinking economies should serve as early indicators to financial institutions to be more alert of potential repayment problems in the future. For entrepreneurs, they must be able to identify the causes of these problems so that they can be more cautious and prepared. Thus, it is expected that this study will identify the factors that cause the occurrence of the repayment problem and ascertain the factors influencing borrowers' accountability.

2. REVIEW OF THE LITERATURE

Timely loan repayment is the key for sustainability of financial institutions; however, several socio-economic and institutional factors may affect the ability to make repayment (Angelucci et al., 2012; Ganle et al., 2015; Samer et al., 2015; van Rooyen et al., 2012). Indeed, many researchers from various countries have conducted studies in this area in order to understand the factors affecting loan repayment. Mohammed and Wobe (2019) conducted research to examine the factors influencing loan repayment performance among Omo Microfinance borrowers in Wondo Genet Woreda, Ethiopia. The study found that 44.9% of the borrowers did not make the repayment as per the credit schedules. The authors claimed that the major factors that affected the loan repayment performance of the borrowers are their gender, family size, education level, borrowing experience, repayment period, loan period, and advisory visit.

Recently, Fianto, Maulida, and Laila (2019) investigated the determining factors of non-performing financing in Indonesian MFIs. The results showed that age, gender, occupation, and the type of contract affected the non-performance of clients of Islamic MFIs in Indonesia. Next, study was conducted by Bhatt and Tang (2002), focusing on the determinants of loan repayment performance for microcredit schemes in the United States of America (USA). They had examined the socio-economics variables such as gender, educational level, household income, and business characteristics, namely business activities, number of years in business, and business performance. They noted a significant and positive association between higher education level and repayment performance. On the other hand, other variables, namely household income, female borrowers, business activities, and number of years in business do not have a significant impact on repayment behaviour.

The study carried out by Kuhn and Darroach (1998) identified the problem of default among microfinance borrowers in South Africa. This study examined various factors associated with loan default such as the loan amount approved, collateral issues, and administration cost. This study stated that loan amount could influence the repayment rate because loans tended to be associated with collaterals. The study in Africa was continued by Cassar et al. (2007) to present evidence from participation in trust and microfinance games. The researchers focused on individual and group lending approach to present evidence that personal trust between group members and social homogeneity are more important in influencing repayment behaviour among the group members. The variables examined included the element of shocks, the effect of other contributions, personal trust, and generalised trust. The result found that personal trust between specific pairs of group members significantly affect

the repayment performance compared with the high degree of social capital between group members which is probably insufficient to increase the repayment rates.

Zeller (1996) also investigated the determinants of microfinance repayment performance in group-based lending in Madagascar. However, this study looked at a different aspect from the previous study. The study focused on the effects of programme design as well as community and group characteristics as determinants of repayment performance for group lending. The sample data were based on six different lending programmes in Madagascar. The study found that to mitigate the risk of group lending, the diversification of the members' asset portfolio² should be implemented so that the repayment rate will improve even if the communities are facing high-risk exposure. Subsequently, C.C Eze (2007) studied the determinants of loan repayment in Southeast Nigeria. The author revealed that the loan amount disbursed, the age of beneficiaries, household income, number of years of formal education, and occupation are significant determinants of loan repayment.

A further study was conducted by Godquin (2004), who examined loan repayment performance in Bangladesh. His analysis was focused on the impact of group lending, non-financial products, and great incentives towards repayment performance. He found a positive but non-significant correlation between gender and loan repayment. In a more recent study, Mekonnen (2015) had examined the determining factors of loan repayment performance among rural women borrowers of saving and credit cooperatives in rural Dire Dawa, Ethiopia. The variables investigated include livestock ownership, loan supervision, education level, loan size, profits derived from activities that were financed by the loan, timeliness of loan release, suitability of loan repayment period, income from other activities, age, celebrating and participating in social festivals, and loan diversion. The results were mixed, showing either significant positive or negative. Meanwhile, Chaudhary and Ishfaq (2003) investigated the creditworthiness of rural borrowers in Pakistan. They found a higher probability of loan repayment among borrowers who attained a higher educational level, were not in the farming business, were female borrowers, and who utilised the loan proceeds for investment purpose.

3. THEORETICAL FRAMEWORK

The adoption of the reinforcement theory, this study will examine the impact of punishments and rewards in order to encourage the borrowers to be more accountable. According to Skinner (1931), human behaviour can be altered based on the impact that would apply to them. This opinion is consistent with Bandura (1974), who argued that human behaviour occurs because of the reaction to the environment or as a consequence of a person's history. In addition, the behaviour may occur due to reinforcement and punishment that motivates the m to perform (Schultz, 2015). Dawson, M. E. (1974) also mentioned that people's behaviour cannot be learnt even with repetitive, paired experience unless it is correlated with them.

To support the theory of reinforcement, related theories have been employed to identify the variables that could be associated with the repayment behaviour. The theory of behaviour and asymmetric information have been applied as supplementary theories in the variable selection. The theory of behaviour forms the basis of the theory of reinforcement but this theory places more emphasis on human behaviour. Hence, it could potentially be used to support the dependent variable, namely borrowers' repayment behaviour. The correlation between reinforcement and repayment behaviour is in ensuring that the borrowers become good paymasters and the same time ensuring their security. The theory of asymmetric information has been selected because it is related to information, which is important in guiding a person to make the right decision. The theory of reinforcement is indirectly related to information, as this theory will work only based of information and the surrounding effects. Thus, in ensuring that the borrowers will honour their loan repayment obligations, genuine information has to be delivered to them, as insufficient information may affect their future loan performance.

In summary, the correlations between the variables and the reinforcement theory are as follow. Firstly, is financial strength, which is a crucial ingredient for business sustainability. However, it is not a guarantee that the borrower can perform the loan repayment. Hence, the reinforcement approach can encourage them to performance the obligation and increase the sense of responsible. Second is religiosity, in the Islamic dimension, the views on reward and punishment are numerous, extensive, and comprehensive. Reward and punishment can happen between man and God, between man and man, and between man and the universe, and this includes his deepest self (Nazri et al., 2011). When people practise religion, they will refrain from doing anything useless or that can destroy them. Next is the understanding of the contract. Generally, contracts are agreements in place between two

² A portfolio can be defined as a grouping of financial assets such as cash equivalents, commodities, stocks, currencies, and bonds. Asset portfolio is asset-backed funds to invest or transfer to property or shares, with the purpose to be liquidated as collateral and not deposited with a bank or building society 0 (Reverso Dictionary, 2017)

parties that should be binding on them (Fayyad, 2013). The element of reward and punishment should be clearly stated in the contract because it can give an early signal regarding the effect to be imposed (Central Bank of Malaysia, 2012). Finally, business performance is about how the owner of the company drives and performs the business (Achim & Borlea, 2013). Performance is related to the effectiveness of management, financial stability, and operational performance (Venkatraman & Ramanujam, 1986). Every company has rules that must be followed to ensure that all parties carry out their duties perfectly. In the rules, the elements of reward and punishment must be applied to help all parties to achieve their targets (Bandura, 1974; Nazri et al., 2011). The effect of reward and punishment will affect the behaviour of all parties, and it can play a role in improving a company's performance.

Furthermore, to complete the study on determining the issue of repayment performance, the variable of accountability will be used as a mediator to enhance the correlation between the independent and dependent variables. According to Dixon et al. (2006) and Lewis (2006), accountability is a key factor that affects the repayment behaviour of microfinance borrowers. In this regard, this study has developed a conceptual framework based on a single layer³ approach to determine borrowers' repayment behaviour under the micro finance financing.

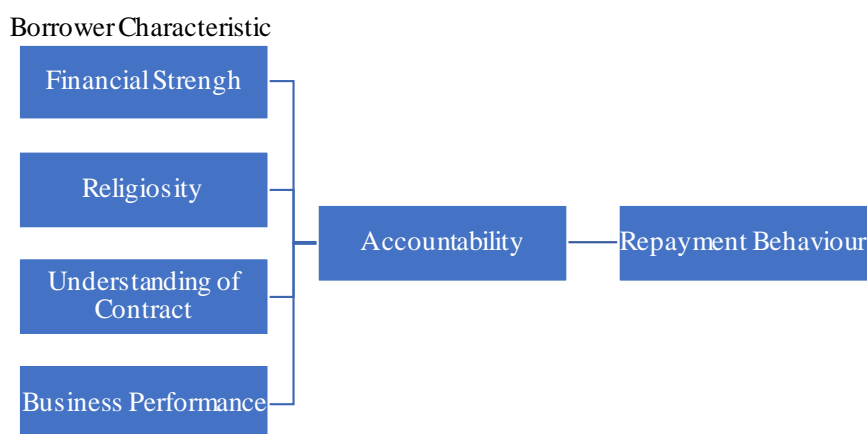

Figure 2: Theoretical Framework

Based on the discussion and framework justifications mentioned above, the hypothesis below is postulated:

H ₁	There Is A Positive Significant Relationship Between Borrower Characteristic And Repayment Behaviour <i>H_{1a}: There is positive significant relationship between financial strength and repayment behaviour</i> <i>H_{1b}: There is positive significant relationship between religiosity and repayment behaviour</i> <i>H_{1c}: There is positive significant relationship between contract knowledge and repayment behaviour</i> <i>H_{1d}: There is positive significant relationship between business performance and repayment behaviour</i>
H ₂	There is a positive significant relationship between borrower characteristic and accountability <i>There is a positive significant relationship between financial strength and accountability</i> <i>H_{2b}: There is a positive significant relationship between religiosity and Accountability</i> <i>H_{2c}: There is a positive significant relationship between contract knowledge and accountability</i> <i>H_{2d}: There is a positive significant relationship between business performance and accountability</i>
H ₃	There is Positive Significant Relationship Between Accountability of The Borrower and Repayment Behaviour
H ₄	The Relationship Between Borrower Characteristic and Repayment Behaviour is Mediated Positively by The Level of Accountability. <i>H_{4a}: The relationship between financial strength and repayment behaviour is mediated positively by the level of accountability</i> <i>H_{4b}: The relationship between religiosity and repayment behaviour is mediated positively by the level of accountability</i> <i>H_{4c}: The relationship between contract knowledge and repayment behaviour is mediated positively by the level of accountability</i> <i>H_{4d}: The relationship between business performance and repayment behaviour is mediated positively by the of accountability</i>

³ Direct relationship between independent and dependent variable (Greaves et al., 2017).

4. DATA ANALYSIS AND RESULT

A total of 900 questionnaires were distributed to all the microfinance borrowers under the rural funding economic scheme (SPED). The questionnaires were distributed to two banks namely Bank Rakyat and SME Bank as they were the representative of KKLW running this programme. Out of the total questionnaires distributed, 302 were returned which is equivalent to a 22.33 percent response rate. However, 42 surveys were excluded because the respondents provided the same answers (straight lining) to all questions, with more than 50 percent of unanswered items and issues with outliers. Therefore, the result is an effective and valid sample of 260 respondents. A summary on the rate of return of the questionnaires is illustrated in Table 2.

Table 2: Response Pattern

Institution	Number of Borrower – 2016 - 2018	Northern & Eastern Region - 2016 – 2018	Q Distributed	Response Rate Received	Valid – After Screening Test	%
Bank Rakyat	3,927	1,349	900	186	160	18
SME Bank				116	100	11
Total	3,927	1,349	900	302	260	29

Source: Kementerian Kemajuan Luar Bandar & Wilayah (KKLW), (2018)

4.1 Profiles of Respondents

After discussing and describing the process of data screening, the general background of individuals who attended and answered the questionnaire in this research were further investigated. The data analysis and all information are presented using actual figures and percentages to simplify the interpretation. Therefore, the final sample consists of a total of 260 respondents who were then categorised based on gender, level of education, number of years in present position, and working experience in the organisation involved.

Table 3: Profile of Respondents

Background	Frequency	Percent
Gender		
Male	125	48.1
Female	135	51.9
Ethnicity		
Bumiputera	260	100.0
Age		
18 - 30	65	25.0
31 – 45	133	51.2
46 an above	62	23.8
Married		
Married	207	79.6
Singgle	53	20.4
Education		
Secondary School	199	76.5
Diploma	40	15.4
Degree	21	8.1
Occupation		
Business	230	88.5
Private Sector	29	11.2
Government Sector	1	0.4
Income		
RM1,000 and below	32	12.3
RM1,001 - RM4,000	93	35.8
RM4,001 - RM7,000	59	22.7
RM7,001 - RM11,000	49	18.8
RM11,001 - RM15,000	12	4.6
RM15,000 and above	15	5.8
Religion		
Islam	260	100.0

These statistics data provide insight into the demographic profiles of respondents who answered through online and offline questionnaires. The result showed that the response rate was 29% from 900 questionnaires distributed. Among these respondents, 48.1% were males and 51.9% were females. The majority of respondents were between the age of 31 to 45 years (51.2%) followed by those of the age 18 to 30 years (25%), and 46 and above (23.8%). A total of 207 respondents were married (79.6%) while the rest were single (20.4%). All the respondents were Bumiputra since the financing was only offered to Bumiputra.

A total of 199 respondents (76.5%) had STPM education and below, 40 respondents (15.4%) had Diploma and the remaining 21 respondents (8.1%) had a Bachelor's Degree. In correspondence with the population frame, most of the respondents were entrepreneurs (88.5%), followed by those working in the private sector (11.2%) and only (1%) of the respondents were in the government sector. In terms of income background, 12.3% of the respondents earned less than RM1,000, 35.8% earned between RM1,001 to RM4,000; 22.7% earned between RM4,001 to RM7,000; 18.8% earned between RM7,001 to RM11,000; and 94.6% earned between RM11,001 to RM15,000, while the remaining 5.8% respondents earned over RM15,000.

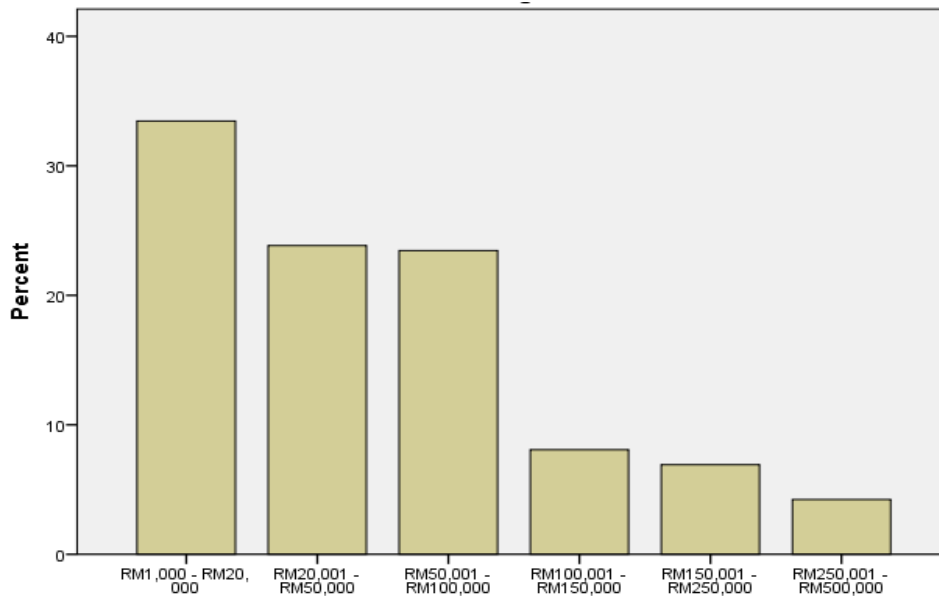

Figure 3: The amount of financing

In terms of the amount of financing, most of the borrowers applied for financing of RM1,000 to 20,000.00 in which they represented 33.5%. Meanwhile, the number of borrowers who applied for financing of RM20,000 to RM50,000 and financing of RM50,001 to RM100,000 were almost the same, at 23.8% and 23.5% respectively. Furthermore, the percentage of borrowers who applied for financing of RM100,001.00 to RM150,000.00 was 8.1% while those who applied for financing of RM150,001 to RM250,000 was 6.9%. The remaining 4.2% of the borrowers applied for financing amount of RM250,000 to RM500,000. In conclude, most of the borrower are received financing amount in range of RM20,000 to RM50,000.

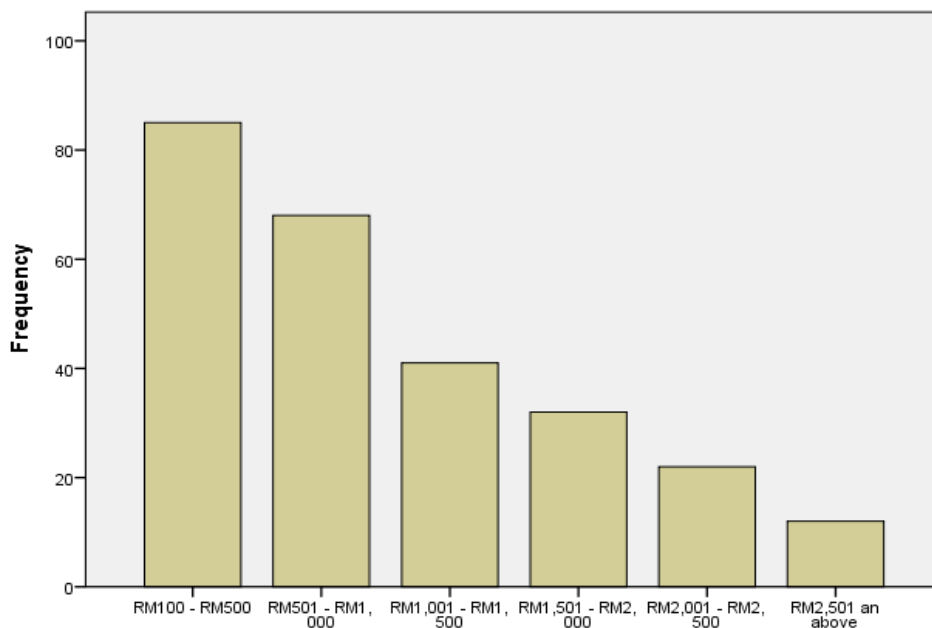

Figure 4: Monthly Repayment

Figure 4 shows the statistics result for monthly instalment commitment, which is closely related with the financing amount. The percentage of borrowers with monthly instalment of RM100 to RM500 (for financing of RM20,000 and below) was 85%, followed by those with monthly instalment of RM501 to RM1,000 (for financing of RM30,000-RM50,000), which represented 26.2%. Next, the borrowers with monthly instalment of RM1,001 to RM1,500 constituted 15.8% while those with monthly instalment of RM1,501 to RM2,000 comprised 12.3%. Meanwhile, borrowers with monthly instalment of RM2,001 to RM2,500 represented 8.5% (considered as the second lowest) and those with monthly instalment of RM2,501 and above represented the remaining 4.6%. Based on the bar graft, the highest borrower commitment is for monthly instalment of RM100 to RM500 which is for financing amount of RM20,000 to RM50,000, whereas the smallest percentage is recorded by monthly instalment of more than RM2,500.00. Only a small number of borrowers were qualified to apply for financing of more than RM150,000.00.

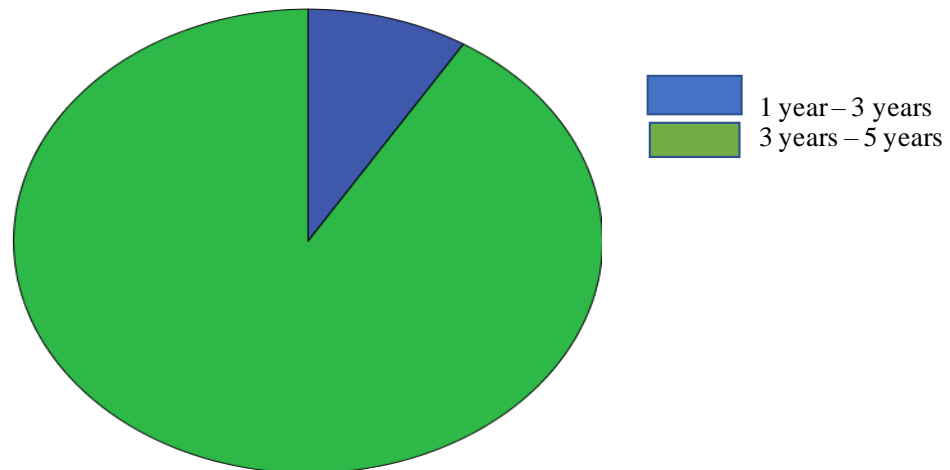

Figure 5: Financing Tenure

In regard to financing tenure, the longest tenure is three to five years which comprises 91.2% of borrowings compared to a tenure of one to three years which only constitutes 8.8%. Most of the borrowers preferred to choose longer tenure because the instalment amount is lower than the tenure of shorter period. A longer period will give more comfort to borrowers in terms of monthly commitment.

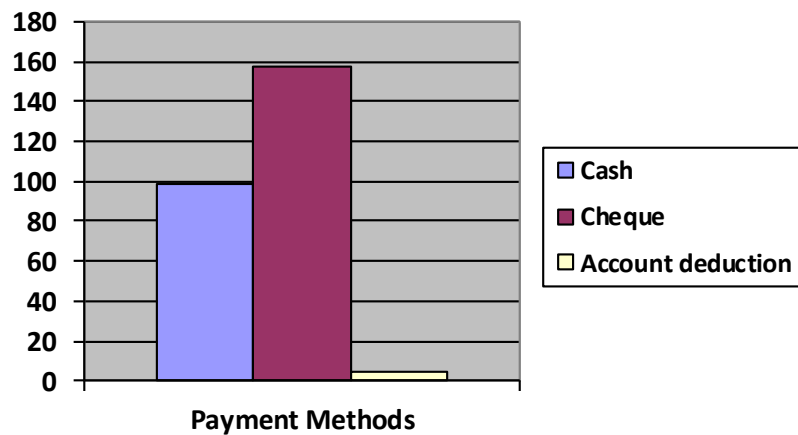

Figure 6: Payment Method

The bar chart in Figure 6 shows the payment method applied by respondents. The descriptive analysis shows that paying via cheque was the most often utilised method, which was used by a total of 157 respondents. The second most regularly used payment method was via cash, either through the counter, CDM, or online banking (99 respondents), and the third most frequently used method was through account deduction (4 respondents). Most borrowers preferred payment using cheques because it is easier. Borrowers can submit many cheques to the bank and simply leave it to the bank to deduct payment when payment is due. Over-the-counter payment recorded the lowest percentage for reasons related to time and distance. Most of the borrowers were too busy with their business and daily activities and thus, faced difficulties in going to the bank.

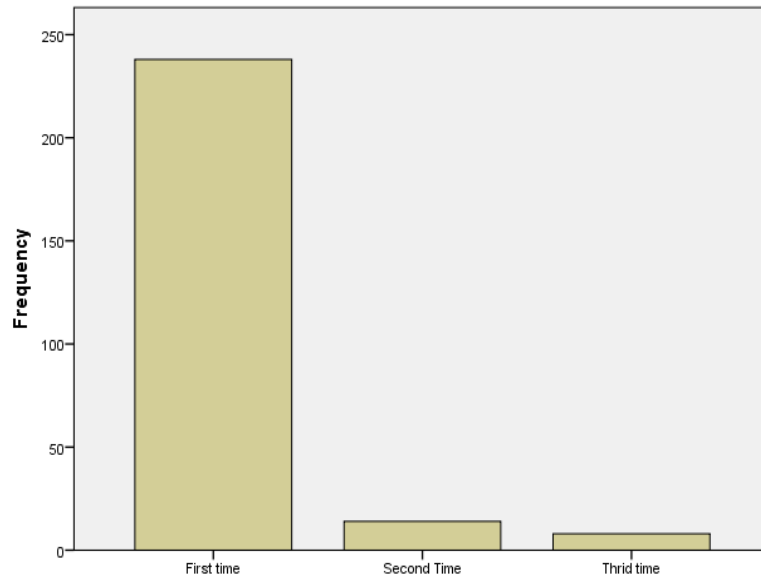

Figure 7: Number of financing application

First time borrowers recorded the highest percentage at 91.5% compared to borrowers of second and third time who constituted 5.4% and 3.1% respectively. The percentage of borrowers is based on the amount of financing in which a higher percentage was recorded for financing of small amount. Second and third time borrowers usually recorded large financing amount because of overlapping or additional financing amount.

4.2 .Measurement Model Assessment

The validity and reliability of the measurement model for this study are evaluated using the following analyses: internal consistency reliability, indicator reliability, convergent validity, and discriminant validity. To check the consistency reliability, the algorithm analysis was run by using the Smart PLS 3.0. The details are as in the following Table 4 and figure 8, which shows the internal consistency reliability.

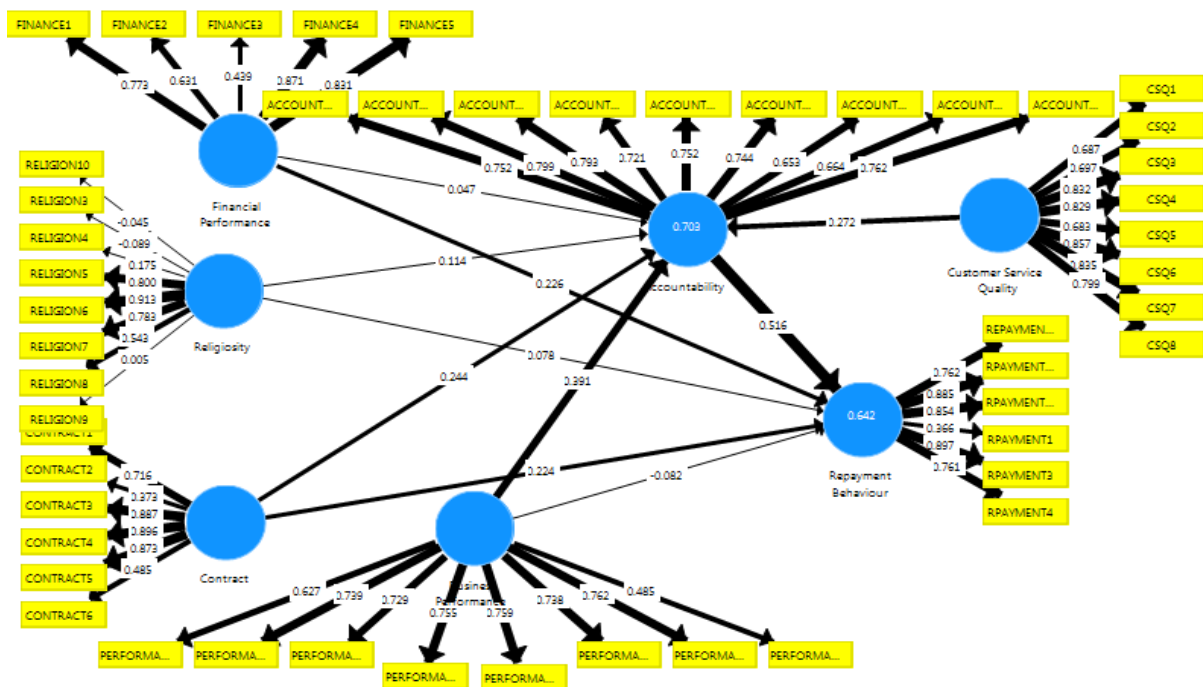

Figure 8: Alorism Analysis

Table 4: Internal Consistency Reliability

Construct	Items	Loading	Cronbach's Alpha	rho_A	CR	AVE
Financial Performance	Finance 1	0.773	0.758	0.801	0.842	0.527
	Finance 2	0.631				
	Finance 3	0.44				
	Finance 4	0.871				
	Finance 5	0.831				
Religiosity	Religion5	0.813	0.795	0.887	0.860	0.613
	Religion6	0.929				
	Religion7	0.793				
	Religion8	0.547				
Understanding Of Contract	Contract1	0.714	0.844	0.899	0.891	0.629
	Contract3	0.889				
	Contract4	0.901				
	Contract5	0.881				
	Contract6	0.508				
Business Performance	Performance1	0.639	0.860	0.859	0.893	0.545
	Performance2	0.759				
	Performance3	0.723				
	Performance4	0.742				
	Performance5	0.784				
	Performance6	0.743				
Repayment Behaviour	Repayment1	0.366	0.854	0.897	0.896	0.602
	Repayment2	0.897				
	Repayment3	0.762				

	Repayment4	0.885				
	Repayment5	0.761				
	Repayment6	0.854				
Customer Service Quality	CSQ1	0.688	0.907	0.908	0.925	0.609
	CSQ2	0.698				
	CSQ3	0.832				
	CSQ4	0.829				
	CSQ5	0.683				
	CSQ6	0.857				
	CSQ7	0.835				
	CSQ8	0.798				
Accountability	Accountability1	0.752	0.897	0.903	0.915	0.547
	Accountability2	0.798				
	Accountability3	0.793				
	Accountability4	0.720				
	Accountability5	0.753				
	Accountability6	0.745				
	Accountability7	0.655				
	Accountability8	0.666				
	Accountability9	0.761				

4.2.1 Indicator Reliability

This research accepts factor loadings of more than 0.4 as suggested by (Hulland, John, 1999; Kwong-Kay Wong, 2013). Table 4 shows all the items that have obtained loading value of more than 0.4 except Religion 3, Religion 4, Religion 9, Religion 10, Contract 2 and Performance 9, which were deleted since each item obtained a low loading value of 0.089, 0.0.175, 0.005, 0.0045, 0.379 and ⁴0.485 respectively.

4.2.2 Convergent Validity

The measurement model's convergent validity is assessed by examining its average variance extracted (AVE) value. According to Bagozzi and Yi (1988), the value of AVE should be 0.5 or higher for a validity to be achieved. Table 4 shows that all constructs have AVE value that ranges from 0.527 to 0.629 and it satisfies the recommended

⁴ Item PERFORMANCE9 still need to deleted even though loading 0.485 because if was effected AVE value.

threshold value of 0.5. Hence, as illustrated by the result, the measurement model of the study demonstrated an adequate convergent validity.

4.2.3 Discriminant Validity

In this research, the measurement model's discriminant validity is assessed through three measurements: 1) Fornell and Larcker's (1981) criterion, 2) cross-loading, and 3) HTMT. The measurement model has a discriminant validity when 1) the square root of the AVE exceeds the correlations between the measure and all other measures, 2) the indicators' loadings are higher against their respective construct compared to other constructs, and 3) the value of HTMT is greater than 0.9. The results showed that all square roots of AVE exceeded the off-diagonal elements in their corresponding row and column. In Table 5, the bolded elements represent the square roots of the AVE and the non-bolded values represent the intercorrelation value between constructs. In conclusion, all off-diagonal elements are lower than the square roots of AVE and thus, it was confirmed that the Fornell and Larcker's criterion is accepted.

The next assessment of discriminant validity is via a Heterotrait-monotrait (HTMT) test. The value of HTMT for each construct should be lower than 0.9 and the value was recommended by Gold et al. (2001) and Henseler et al., (2015). Table 6 shows that the HTMT output for all the constructs in this research have no discriminant validity problem. In conclusion, the overall result for reliability and validity tests conducted on the measurement model is satisfactory and confirmed, an indicator that the measurement model for this study is valid and appropriate to be used to estimate parameters in the structural model.

Table 5: Fornell and Larcker's Inter-correlation Matrix

	Accountability	Business Performance	Contract	Customer Service Quality	Financial Performance	Religiosity	Repayment Behaviour
Accountability	0.739						
Business Performance	0.743	0.738					
Contract	0.630	0.520	0.793				
Customer Service Quality	0.671	0.558	0.454	0.781			
Financial Performance	0.563	0.526	0.440	0.587	0.726		
Religiosity	0.361	0.347	0.298	0.178	0.1	0.783	
Repayment Behaviour	0.754	0.555	0.630	0.673	0.58	0.323	0.776

Table 6: The HTMT Output Using Smart PLS

	Accountability	Business Performance	Contract	Customer Service Quality	Financial Performance	Religiosity	Repayment Behaviour
Accountability							
Business Performance	0.845						
Contract	0.714	0.615					
Customer Service Quality	0.714	0.623	0.492				
Financial Performance	0.654	0.654	0.524	0.691			
Religiosity	0.410	0.393	0.337	0.208	0.221		
Repayment Behaviour	0.810	0.622	0.708	0.742	0.684	0.368	

4.3 Structural Model

This section on measuring the structural model involves assessing R², beta, and the corresponding t-values (Hair, Hult, Ringle, & Sarstedt, 2014). To acquire the t-values, a procedure of bootstrapping with 5000 resamples was used. Besides these fundamental measures, researchers were supposed to report predictive relevance (Q²) and effect sizes (f²) (Hair et al., 2014; Soto-Acosta, Popa, & Palacios-Marqués, 2016) as well. In addition, this research continued to assess the mediation relationships that were proposed in the conceptual framework. The bootstrapping analysis has been running to identify the relationship and significant level.

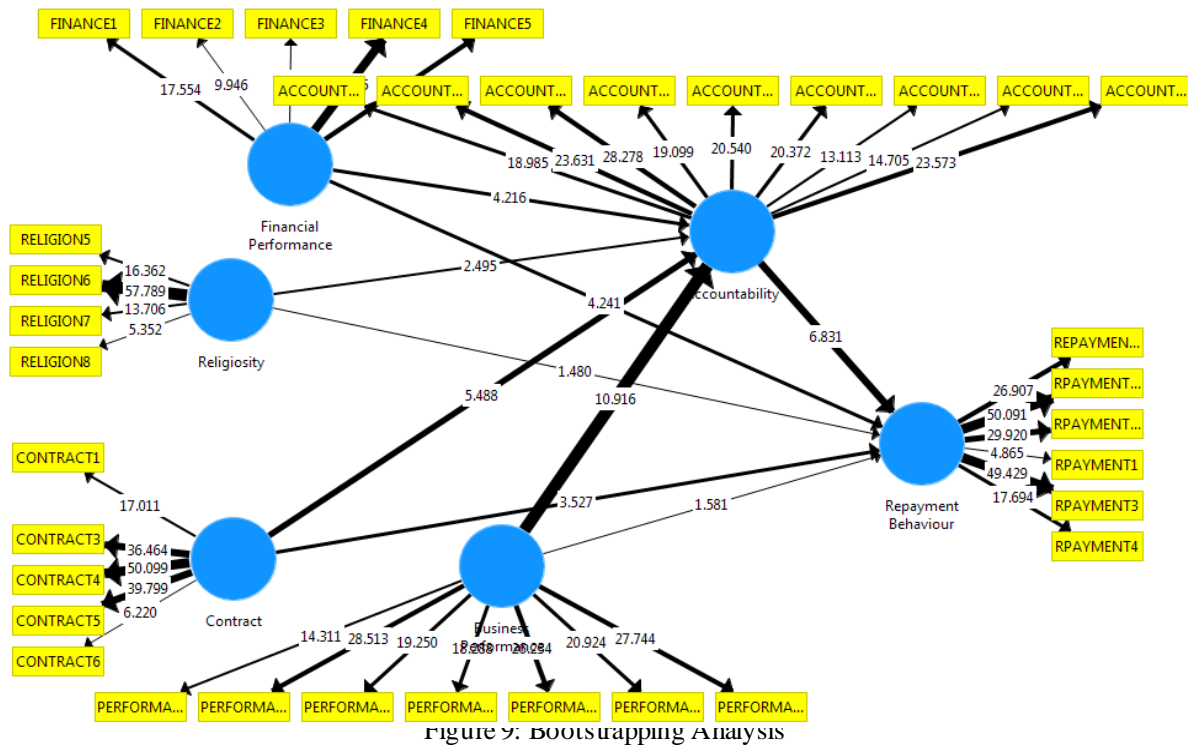

4.3.1 Path Coefficients

The path coefficients must surpass 0.100 to account for a particular impact within the model and be significant at least at the 0.05 level of significance (Huber et al., 2007). In reference to table 7, this study firstly looked at the antecedent to accountability. Financial strength ($\beta = 0.182$, $p < 0.01$), religiosity ($\beta = 0.102$, $p < 0.05$), understanding of contract ($\beta = 0.2777$, $p < 0.01$) and business performance ($\beta = 0.468$, $p < 0.01$) were positively related to accountability explaining 65.6% of the variance in the accountability. Next, for the antecedent to repayment behaviour, financial strength ($\beta = 0.23$, $p < 0.01$) and understanding of contract ($\beta = 0.228$, $p < 0.01$) were positively related to repayment behaviour explaining 64.1% of the variance in the repayment behaviour. However, religiosity ($\beta = -0.075$, $p > 0.05$) and business performance ($\beta = -0.101$, $p > 0.05$) were not related to repayment behaviour.

Table.2: Result of the Structural Path Analysis

Hypothesis	Relationship	Std Beta	Std Error	t-value	P-Values	Decision	f^2	R^2	Q^2
H1a	Financial Performance -> Repayment Behaviour	0.23	0.054	4.241	0.000	Supported	0.093	0.641	0.35
H1b	Religiosity -> Repayment Behaviour	0.075	0.051	1.48	0.139	Not Supported	0.013		
H1c	Contract -> Repayment Behaviour	0.228	0.065	3.527	0.000	Supported	0.084		
H1d	Business Performance -> Repayment Behaviour	-0.101	0.065	1.581	0.114	Not Supported	0.012		
H2a	Financial Performance -> Accountability	0.182	0.043	4.216	0.000	Supported	0.065	0.656	0.332
H2b	Religiosity -> Accountability	0.102	0.04	2.495	0.013	Supported	0.025		
H2c	Contract -> Accountability	0.277	0.05	5.488	0.000	Supported	0.15		
H2d	Business Performance -> Accountability	0.468	0.043	10.916	0.000	Supported	0.376		
H3	Accountability -> Repayment Behaviour	0.526	0.077	6.831	0.000	Supported	0.262		

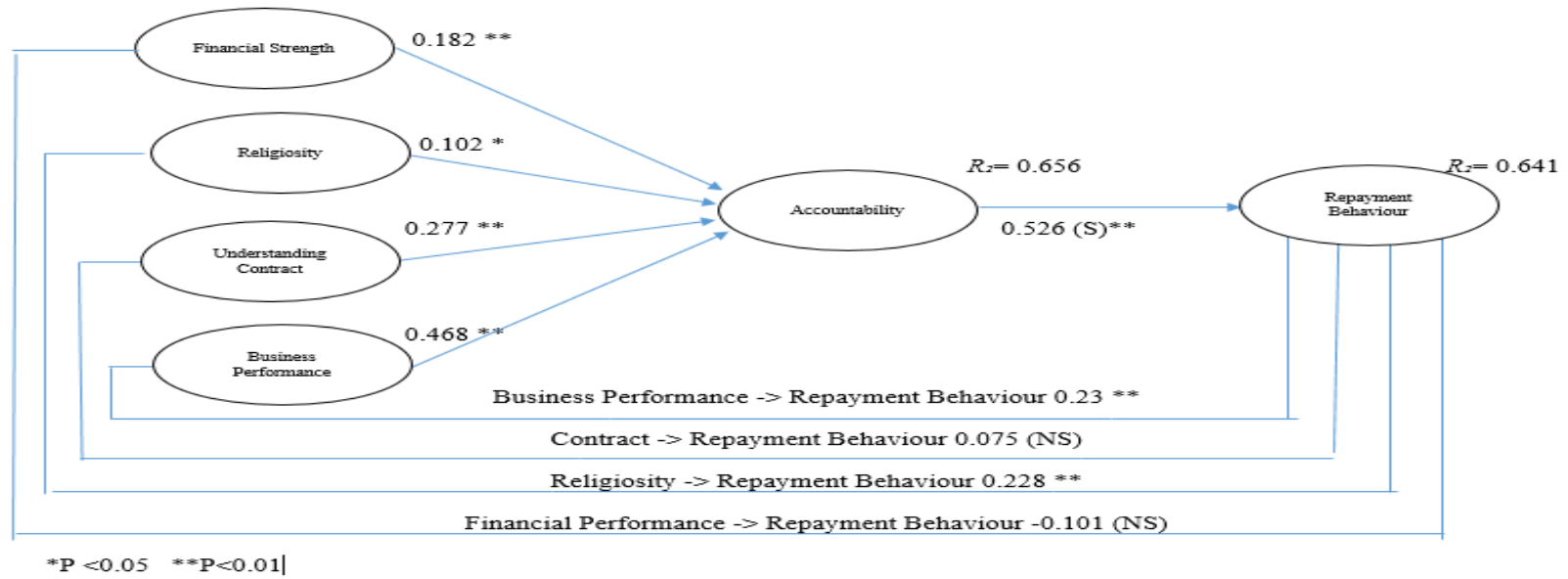

Figure.10: Results of Structural Model

4.4 Mediating Analysis

To test the mediation analysis, this research employed the analysis of indirect effect as suggested by Preacher and Hayes (2008) by using the bootstrapping method (with two tails) analysis revealed (refer Table 8) that the indirect effect of accountability between financial strength ($\beta=0.091$) and religiosity ($\beta=0.053$) was positively significant with t -value of 3.481 and 2.358 respectively. The relationship between understanding of contract ($\beta=0.147$) and business performance ($\beta=0.249$) has higher correlation and was strongly positive significant with a t -value of 4.885 and 5.149 respectively. This research also confirms that there is mediation, given that the indirect effect of financial strength 0.091, 95% Boot CI: [LL=-0.044, UL=0.145]; religiosity 0.053, 95% Boot CI: [LL=-0.120, UL=0.1]; understanding of contract 0.147, 95% Boot CI: [LL=-0.092, UL=0.211]; and business performance 0.249, 95% Boot CI: [LL=-0.16, UL=0.3510] do not straddle a 0 in between. Based on the above results, this research concludes that the mediation effect of accountability on the relationship between financial strength, religiosity, understanding of contract, business performance, and repayment behaviour is statistically significant. Therefore, all the hypotheses are supported.

Table.3: Indirect Analysis

Ho	Relationship	Std Beta	Std Error	t-value	Decision	LL	UL
H4a	Financial Performance ->Repayment Behaviour	0.0910	0.0260	3.4810	Yes	0.0440	0.1450
H4b	Religiosity->Repayment Behaviour	0.0530	0.0220	2.3580	Yes	0.0120	0.1000
H4c	Contract -> Repayment Behaviour	0.1470	0.0300	4.8850	Yes	0.0920	0.2110
H4d	Business Performance ->Repayment Behaviour	0.2490	0.0490	5.1490	Yes	0.1600	0.3510

5. DISCUSSION OF FINDINGS

Based on **H1**, the result shows that two hypotheses are significant while another two hypotheses are not significant. For H1a, the relationship between financial strength with repayment behaviour is positively significant ($\beta = 0.23$, $p= 0.0$). The beta value recorded the highest value compared with other variables. As mentioned by Tinoco, (2013) the company that faces difficulties in fulfilling its financial obligation will have the problem of default. Kenton (2019) stated that a company or an individual cannot generate income from business activities which means it is unable to manage its finances especially the operation cost, which will lead to default.

H1b: There is positive significant relationship between religiosity and repayment behaviour. Religiosity did not directly affect repayment behaviour and it resulted in no significant relationship ($\beta = 0.075$, $p=0.139$). This result contradicts with the theory that religion has the power to influence human behaviour because it is related with human spirituality. This result indicates that the knowledge of religion does not directly influence borrower behaviour in repayment. As mentioned under the theory of reinforcement, people's behaviour depends on the consequences of whether they gain benefits or suffer losses (Calvin & McDowell, 2016). Hence, the borrower does not feel the effect will imposed to them if not implementing the religion. As mentioned by (Abou-Youssef et al., 2015) the implementing of religious is not about enough with knowledgeable but most importantly is about taqwa which is the element to drive knowledge doing right things.

H1c: There is positive significant relationship between understanding of contract and repayment behaviour. This result supported the hypothesis by showing positive significant relationship ($\beta = 0.228$, $p=0.0$) between contract and repayment. The beta value recorded the second highest value compared to other variables, which means that the contract variable has higher correlation with repayment behaviour. This result is parallel with that of the previous study which found that the contract plays a significant role in guiding borrowers to follow the agreement. Most of the borrowers are in default when they fail to fulfil and comply with the agreement of a promissory note. *H1d: There is positive significant relationship between business performance and repayment behaviour.* The result found that business performance has negative correlation ($\beta = - 0.101$, $p = 0.114$) with repayment behaviour. This result contradicts the previous study which showed that good business performance usually can make repayment promptly. Previous studies have established that business performance has positive significant influence on the ability of the borrower to repay debt (Achim & Borlea, 2013; Nawai & Shariff, 2012; Shaharudin, Basri, & Isa, 2016). Likewise, (Nawai, 2013) found that good business performance will more likely lead the borrower to repay the loan on time. This result is supported by the studies by Nannyonga (2000); Onyenucheya & Ukoha (2007); Oke et al., (2007); Von Pischke (1991) who showed that borrowers who have higher business performance have

a higher chance of repaying their loans compared to borrowers facing declining business performance. However, the result showed that the relationship between business performance and repayment is not significant and has no effect on repayment.

The second research question is **2) Does borrower characteristic have significant relationship with the level of accountability?** From the coefficient analysis path, all the variables have a positive significant relationship with accountability. The result for H2a showed positive significant relationship ($\beta = 0.182$, $p = 0.0$) between financial strength and accountability. The relationship between religiosity and accountability also shown positively significant ($\beta = 0.102$, $p = 0.013$). This result is parallel with the finding of Hess (2012) who explored the impact of religiosity on personal financial decisions, specifically in areas of high religious social norms. This finding is consistent with the study by Vasconcelos (2009) who found that religion teaches people to have good behaviour and to be good in decision making.

H2c result shows positive significant relationship between understanding of contract and accountability with positive beta coefficient ($\beta = 0.277$, $p = 0.05$). This result is consistent with the previous study in that all parties are obligated and responsible for the agreement because they are bound by the agreement (Arsyad, 2006; Rodríguez-Meza, 2000). H2d result showed positive significant relationship between business performance and accountability with beta coefficient ($\beta = 0.277$, $p = 0.05$). This beta coefficient recorded the higher value compared with other variables and it is considered as strongly correlated with repayment behaviour. This result is consistent with the previous study by Shu-Teng et al., (2015) who found that business characteristics (business experience) have positive significant relationship with repayment and is supported by a study from Nawai and Shariff (2013) which revealed that business with higher sales earns more profit and has better payment performance.

3) Does the level of accountability have significant relationship with repayment behaviour? The relationship is positively significant ($\beta = 0.526$, $p = 0.01$) as explained by variance of 27.7%. Apparently, this finding is also parallel with the theory of reinforcement and repayment behaviour by (Deng et al., 2016). According to (Deng et al., (2016) the reinforcement learning process is at the heart of successful relationship with repayment behaviour and accountability in which reinforcement encourages borrower to become accountable based on reward and punishment. According to Skinner (1931), human behaviour can be changed based on the impact that is imposed on them.

The fourth research question is **4) Does the level of accountability mediate the relationship with borrower characteristic?** Based on the result, it can conclude that the accountability is positively and significantly mediate all relationships. Compared with direct effect, the result of religiosity and business performance is not significant. The correlation of indirect effect between religiosity and repayment behaviour has shown increased value in beta from 0.075 (direct effect) to 1.02 (indirect effect).

6. CONCLUSION

This study is an attempt to initiate comprehensive research related to payment behaviour, and the objective of this study is to gain a better insight of the internal factors affecting repayment behaviour among microfinance borrowers. Generally, the results of the analysis showed that borrowers' repayment behaviour was affected by their characteristics and accountability. Moreover, religiosity and business performance did not have a significant direct relationship with repayment behaviour. This research also found that accountability played a significant positive role as a mediator between borrower characteristics (financial strength, religiosity, understanding contract, and business performance) and repayment behaviour. Hence, this result expected will significantly contribute to the knowledge of microfinance programme, in which it explains that repayment performance plays an important role in ensuring that microfinance institutions can continue providing microfinance products to micro entrepreneurs and simultaneously help to improve the social economy and alleviate poverty. In practical, the result will help financial institutions to identify early warning signs and some factors that are potentially related to borrower behaviour. Besides, policy makers will be able to identify the underlying causes to achieve the objective of eliminating poverty.

REFERENCE

- Abou-Youssef, M. M. H., Kortam, W., Abou-Aish, E., & El-Bassiouny, N. (2015). Effects of religiosity on consumer attitudes toward Islamic banking in Egypt. *International Journal of Bank Marketing*, 33(6), 786–807. <https://doi.org/10.1108/IJBM-02-2015-0024>
- Achim, M. V., & Borlea, S. N. (2013). Business performances : between profitability, return and growth. *Economic Sciences Series*, 2, 1–12.
- Angelucci, M., Karlan, D., & Zinman, J. (2012). Win some lose some? Evidence from a randomized microcredit program placement experiment by Compartamos Banco. In *Working Paper* (Issue May).
- Arsyad, L. (2006). Assessing factors affecting the repayment rate of microfinance institutions. A case study of village credit institution of Gianyar, Bali. *Gadjah Mada International Journal of Business*, 8(2), 247–273. <http://i-lib.ugm.ac.id/jurnal/download.php?dataId=9971%5Cnpapers3://publication/uuid/0A5D607C-D8C0-4DB1-9D00-169B66486CE6>
- Bandura, A. (1974). *behavior Theory.pdf* (pp. 859–869).
- Bank Rakyat. (2015). *NPL Report 2015 -Rural Development Financing-i Scheme*.
- Berita Harian. (2018). *AIM alu-alukan penegasan PM perkasa wanita dalam perniagaan*. Sinar Karangkraf Sdn. Bhd. <https://www.sinarharian.com.my/article/4741/BERITA/Nasional/AIM-alu-alukan-penegasan-PM-perkasa-wanita-dalam-perniagaan>
- Bernama. (2018). *Tekun Nasional's NPL hits 37.82 pct of total debts*. <http://www.bernama.com/en/news.php?id=1621393>
- Bhatt, N., & Tang, S. Y. (2002). Determinants of Repayment in Microcredit: Evidence from Programs in the United States. *International Journal of Urban and Regional Research*, 26(2), 360–376.
- Bichanga, W. O., & Aseyo, M. L. (2013). *Causes of Loan Default within Micro Finance Institutions in Kenya*. 04(12), 316–335.
- C.C Eze, U. . I. (2007). *Determinants of loan repayment under the indigenous financial system in southeast Nigeria*. 2(2), 116–120.
- Calvin, O. L., & McDowell, J. J. (2016). Extending unified-theory-of-reinforcement neural networks to steady-state operant behavior. *Behavioural Processes*, 127, 52–61. <https://doi.org/10.1016/j.beproc.2016.03.016>
- Cassar, A., Crowley, L., & Wydick, B. (2007). The effect of social capital on group loan repayment: Evidence from field experiments. *Economic Journal*, 117(517), 85–107. <https://doi.org/10.1111/j.1468-0297.2007.02016.x>
- CEIC. (2017). *Malaysia Non Performing Loans Ratio*. <https://www.ceicdata.com/en/indicator/malaysia/non-performing-loans-ratio>
- CEIC. (2019). *Malaysia Non Performing Loans Ratio*. <https://www.ceicdata.com/en/indicator/malaysia/non-performing-loans-ratio>
- Central Bank of Malaysia. (2012). *Guideline On Classification Of Impaired Loans/Financing And Provisioning For Bad And Doubtful Debts*.
- Chaudhary, M. A., & Ishfaq, M. (2003). Credit worthiness of rural borrowers of Pakistan. *The Journal of Socio-Economics*, 32, 675–684. *The Journal of Socio-Economics*, 32, 678–684.
- Chong, F., Morni, F., & Suhaimi, R. (2010). Demographic factors and repayment performance of NBFIs customers in Kuching. *CSSR 2010 - 2010 International Conference on Science and Social Research, C SSR*, 1340–1345. <https://doi.org/10.1109/CSSR.2010.5773748>
- Dawson, M. E., & F. (1974). *The role relational awareness in human autonomic discrimination classical conditioning*.
- Deng, Y., Gu, Q., & He, J. (2016). *Reinforcement Learning and Mortgage Partial Prepayment Behavior*. April.
- Dixon, R., Ritchie, J., & Siwale, J. (2006). Microfinance: accountability from the grassroots. *Accounting, Auditing & Accountability Journal*, 19(3), 405–427. <https://doi.org/http://dx.doi.org.ezlibproxy.unisa.edu.au/10.1108/09513570610670352>
- Fayyad, M. (2013). Classification of Contractual Agreements in Comparative and Islamic Jurisdictions: Does it Make Any Sense? *Arab Law Quarterly*, 27(3), 203–229. <https://doi.org/10.1163/15730255-12341256>
- Fianto, B. A., Maulida, H., & Laila, N. (2019). Determining factors of non-performing financing in Islamic microfinance institutions. *Heliyon*, 5(8). <https://doi.org/10.1016/j.heliyon.2019.e02301>
- Ganle, J. K., Afriyie, K., & Segbefia, A. Y. (2015). Microcredit: Empowerment and disempowerment of rural women in Ghana. *World Development*, 66, 335–345. <https://doi.org/10.1016/j.worlddev.2014.08.027>
- Godquin, M. (2004). Microfinance repayment performance in Bangladesh: How to improve the allocation of loans by MFIs. *World Development*, 32(11), 1909–1926. <https://doi.org/10.1016/j.worlddev.2004.05.011>
- Greaves, R. B., Dietmann, S., Smith, A., Stepney, S., & Halley, J. D. (2017). A conceptual and computational framework for modelling and understanding the non-equilibrium gene regulatory networks of mouse embryonic stem cells. *PLoS Computational Biology*, 13(9), 1–24. <https://doi.org/10.1371/journal.pcbi.1005713>
- Hess, D. (2012). *The impact of religiosity on personal financial decisions*. 14, 1–13.
- Hulland, John, R. I. S. (1999). Use of partial least squares (PLS) in strategic management research: A review of four recent studies. *Strategic Management Journal*, 20(2), 195–204.
- Idama, A. (2014). *The Causes of Loan Default in Microfinance Banks : The Experience of Standard Microfinance Bank , Yola , Adamawa*. 16(11), 74–81.
- Kementerian Kemajuan Luar Bandar & Wilayah (KKLW). (2018). *BOOKLET ' SKIM PEMBIAYAAN EKONOMI DESA ' (SPED)*.
- Kenton, W. (2019). *Financial Distress*. Investopedia. https://www.investopedia.com/terms/f/financial_distress.asp
- KKLW. (2018). *Laporan Prestasi Pembiayaan SPED*.
- Kwong-Kay Wong, K. (2013). Partial Least Squares Structural Equation Modeling (PLS-SEM) Techniques Using SmartPLS. *Marketing Bulletin*, 24, 1–32.
- Lewis, M. K. (2006). Accountability and Islam. *Fourth International Conference on Accounting and Finance in Transition*, 1–16.
- MAG, K. M. and D. (1998). Factors affecting rural medium-term loan repayment: Evidence from a South African development finance institution. In: G Peters and J von Braun (Eds) *Food Security, Diversification and Resource Management: Refocusing the Role of*

- Agriculture? In *Occasional Paper No. 8, International Association of Agricultural Economists* (pp. 322–328). , Ashgate Publishing Co Ltd, Aldershot, UK, 1998.
- Mekonnen, M. (2015). *DETERMINANTS OF LOAN REPAYMENT PERFORMANCE OF RURAL WOMEN BASED SAVING AND CREDIT COOPERATIVES' MEMBERS: THE CASE OF DIRE DAWA ADMINISTRATION*.
- Mohammed, A. F., & Wobe, M. H. (2019). Factors Affecting Loan Repayment Performance of Microfinance Institution Borrowers. *International Journal of Applied Behavioral Economics*, 8(2), 27–43. <https://doi.org/10.4018/ijabe.2019040103>
- Mokhtar, S. H. (2011). *Microfinance Performance in Malaysia*. 134.
- Morduch, J. (2006). *Smart subsidies*. *ESR Review*, 8(1), 10.
- Nawai, N. B. M. N. B. M. S. (2013). Determinants of Repayment Performance in Microfinance Programmers in Malaysia. *Proceedings of the 2nd Applied International Business Conference (AIBC2013)*, 11(December), 7–8.
- Nawai, N., & Shariff, M. N. M. (2012). Factors Affecting Repayment Performance in Microfinance Programs in Malaysia. *Procedia - Social and Behavioral Sciences*, 62, 806–811. <https://doi.org/10.1016/j.sbspro.2012.09.136>
- Nazri, M., Ahmad, M., & Yusoff, A. (2011). The Concept of Rewards and Punishments in Religion: A Special Reference to Kitab Al-Adab of Sahih Bukhari. *World Journal of Islamic History and Civilization*, 1(4), 249–254. [http://www.idosi.org/wjihc/wjihc1\(4\)11/5.pdf](http://www.idosi.org/wjihc/wjihc1(4)11/5.pdf)
- Otero, M. (1999). Bringing Development Back , into Microfinance. *Journal of Microfinance*, 1(1), 1–10.
- Oxford Dictionary. (2017). *English Oxford Living Dictionary*. <https://en.oxforddictionaries.com/definition/accountability>
- PNB. (2018). *PNB net income up 17% to P9.6B in 2018*. <https://www.pnb.com.ph/index.php/pnb-net-income-up-17-to-p9-6b-in-2018>
- Reverso Dictionary. (2017). *asset portfolio definition, asset portfolio meaning*. <https://dictionary.reverso.net/english-definition/asset+portfolio>
- Robinson, M. S. (2001). The Microfinance Revolution Sustainable Finance For The Poor. *The World Bank, Washington, D.C.*, 9.
- Rodríguez-Meza, J. L. (2000). *GROUP AND INDIVIDUAL MICROCREDIT CONTRACTS: A DYNAMIC NUMERICAL ANALYSIS*.
- Samer, S., Majid, I., Rizal, S., Muhamad, M. R., Sarah-Halim, & Rashid, N. (2015). The Impact of Microfinance on Poverty Reduction: Empirical Evidence from Malaysian Perspective. In *Procedia - Social and Behavioral Sciences* (Vol. 195, pp. 721–728). Elsevier B.V. <https://doi.org/10.1016/j.sbspro.2015.06.343>
- Schultz, W. (2015). Neuronal Reward and Decision Signals: From Theories to Data. *Physiological Reviews*, 95(3), 853–951. <https://doi.org/10.1152/physrev.00023.2014>
- Shaharudin, Z., Basri, M. N. A., & Isa, M. Y. B. M. (2016). Factors Influencing Payments Behavior among Customers of Islamic Retail Financing. *Journal of Islamic Banking and Finance*, 4(2), 34–37. <https://doi.org/10.15640/jibfv4n2a5>
- Shu-Teng, L., Zariyawati, M. A., Suraya-Hanim, M., & Annuar, M. N. (2015a). Determinants of Microfinance Repayment Performance: Evidence from Small Medium Enterprises in Malaysia. *International Journal of Economics and Finance*, 7(11), 110. <https://doi.org/10.5539/ijef.v7n11p110>
- Shu-Teng, L., Zariyawati, M. A., Suraya-Hanim, M., & Annuar, M. N. (2015b). Determinants of Microfinance Repayment Performance: Evidence from Small Medium Enterprises in Malaysia. *International Journal of Economics and Finance*, 7(11), 110. <https://doi.org/10.5539/ijef.v7n11p110>
- Sinha, D. (1998). Economic growth and government expenditure in China. *Business*.
- Skinner, B. F. (1931). The concept of the reflex in the description of behavior. *Journal of General Psychology*, 5, 427–458.
- Sun, T. (2018). *PUNB targets to lower non-performing loans*. SUN MEDIA CORPORATION SDN BHD. <https://www.thesundaily.my/archive/punb-targets-lower-non-performing-loans-JUARCH582133>
- suraya Hanim Mokhtar, G., & Gan, N. & C. (2012). Determinants of microcredit loans repayment problem among microfinance borrowers in Malaysia. *International Journal of Business and Social Research (IJBSR)*, 2, 33–45.
- Tinoco, M. H. (2013). *Financial Distress and Bankruptcy Prediction using Accounting , Market and Macroeconomic Variables by*.
- van Rooyen, C., Stewart, R., & de Wet, T. (2012). The Impact of Microfinance in Sub-Saharan Africa: A Systematic Review of the Evidence. *World Development*, 40(11), 2249–2262. <https://doi.org/10.1016/j.worlddev.2012.03.012>
- Venkatraman, N., & Ramanujam, V. (1986). Measurement of business performance in strategy research: a comparison of approaches أداء قياس الأعمال. *The Academy of Management Review* (Vol. 11, Issue 4, pp. 801–814). <https://doi.org/10.2307/258398>
- Wong, C. Y., & Eng, Y.-K. (2018). *Good-bye GST, Hello SST for Malaysia: In Search of Efficiency Equivalence*. July. <https://doi.org/10.13140/RG.2.2.32578.68809>
- World Bank Group. (2017). *FINANCE & MARKETS GLOBAL PRACTICE Financial Inclusion in Malaysia*. May. <http://documents.worldbank.org/curated/en/703901495196244578/pdf/115155-WP-PUBLIC-GFM08-68p-Fpaperwebversion.pdf>
- Zeller, M. (1996). Determinants of loan repayment in group lending: The role of program design, intra-group risk pooling and social cohesion. *Economic Development and Cultural Change (Forthcoming)*.
- Zhou, Z., Centre, L., Studies, P. P., & Lau, Z. Z. (2014). *GOODS AND SERVICES TAX IN A Policy Analysis*. October 2013.

ROLE OF INTELLECTUAL CAPITAL COMPONENTS AND GOVERNMENT SUPPORT ON ISLAMIC MICROFINANCE INSTITUTION'S PERFORMANCE: A STUDY IN MALAYSIA

Maryam Jameelah Hashim, Nur Afizah Muhamad Arifin & Rahim Khamis

Faculty of Business Management, Puncak Alam Campus, Universiti Teknologi MARA, Malaysia

Abstract

Islamic microfinance institutions (IMFIs) should put a high priority on increasing the firms' intellectual capital (IC) so that they can maintain their excellent performance and can be sustainable. Nowadays, institutions are facing enormous challenges to stay competitive in the present economic environment. Besides, institutions are not only facing difficulties in maintaining their performance, but they have ignored the importance of intellectual capital as a significant production factor that accounts for the economic and financial prosperity of nations. This study aims to examine the role played by intellectual capital components (human capital, customer capital and structural capital) and government support in increasing the Islamic microfinance institutions (IMFIs) performance. This study uses the partial least square – structural equation modeling (PLS-SEM) to analyze the research model and found that it explains 59.7% of the substantial amount of variance in IMFIs performance. Theoretically, the study extends the intellectual capital theory in projecting the IMFIs performance. The empirical results show that the components of IC and government have a significant effect on IMFIs performance.

Keywords: Islamic microfinance institutions performance, intellectual capital, government support, PLS-SEM

1.0 INTRODUCTION

Islamic Microfinance institution's performance (IMFIs) is crucial for ensuring the efficient utilization of funds deposited into the microfinance program by donors and assisting regulators in monitoring the institutions. Assessing the performance of IMFIs involves examining its development towards accomplishing its goals. Therefore, IMFIs need to determine the key challenges to maintain their operations and remaining sustainable. Additionally, it is more sensible for IMFIs to focus on intellectual capital (IC) and further prioritize their relations with government bodies and perform well to remain sustainable in the future. Therefore, assessing the performance of IMFIs has always been one of interest to management teams of the institutions and researchers. Researchers have extended efforts to determine measures for the concept of performance (Bamey, 1991; Edvinsson & Malone 1997; Gogan, 2014; Jancenelle, 2015; Manzari, Kazemi, Nazemi, & Pooya, 2012; Mendes, Mario, & Romao, 2016). Besides, researchers have extended their study by evaluating the relationship between institutions' performance and their intangible assets that could give value added to the institution's performance.

Further, researchers have advocated that microfinance institutions (MFIs) should put a high emphasis on increasing the institutions' intellectual capital so that they can maintain their excellent performance and can be sustainable in the future. Previous researchers from the field of intellectual capital are expressing their arguments that in a contemporary business environment, the ability of financial institutions to deliver and perform successfully is possible only with the help of intellectual capital (Hashim et al., 2015; Halim et al., 2014; Henry and Watkins, 2013; Inkinen, 2015; Khalique et al., 2014, 2015; Khalique and Pablos, 2015). Eventually, by collaborating with Bank Negara Malaysia (BNM), the government of Malaysia realized that microfinancing is very important for the growth of the country's economy. Therefore, in early 2006, the government urged financial institutions comprising development and commercial banks to promote microfinance products to the public.

Increasing global competition compels many financial institutions around the world to achieve outstanding performance. IMFIs need to identify and manage the key drivers of performance more effectively and efficiently. In the current scenario, intellectual capital has been recognized as a vital corporate asset because the conventional performance measurement techniques are incapable of measuring intangible dimensions of institutions' performance (Weqar, Khan, & Raushan, 2020). This study argues that to strengthen the performance, IMFIs should start with an internal analysis and recognize their resources and capabilities. IMFIs

with substantial intangible resources can get a competitive advantage and differentiate themselves from their competitors in a cutting edge business environment. Due to this reason, this study used the theory of intellectual capital as a theoretical foundation. The theory of intellectual capital looks inside the IMFIs to capitalize the intangible resources to enhance the performance. Intellectual capital is also known as a catalyst for generating value-added products, services, and for improving the performance of IMFIs. To thrive and stay alive in a competitive and dynamic business environment, IMFIs have to be competent and innovative.

Consequently, IMFIs need to understand the relationship which exists between intellectual capital, government support, and the institution's performance. In this current study, intellectual capital consists of three components, which are human capital (knowledge and skills), customer capital, and structural capital. Therefore, this study aims to identify the role of intellectual capital components and the government support on the performance of IMFIs.

2.0 LITERATURE REVIEW

2.1 Islamic Microfinance Institutions (IMFIs) performance

There has been an increasing interest in conventional microfinance products recently, and this can be seen, especially in Muslim majority countries. However, Sharma (2010) claimed that traditional microfinance contributes to an increase in debt and poverty, burdens the poor, and has even led to death in some cases. Therefore, IMFIs should provide solutions to alleviate poverty, satisfy the growing needs of Muslim borrowers, and assist the poor in their distress (Dusuki, 2008). The best way to support the poorest of the poor against the evils of greed and fraud involved in conventional microfinance is by implementing the IMFIs principles, which include ethical, moral, and social characteristics (Samad, 2014). Even though the demand for IMFIs is strong, but the supply of Islamic products is still trivial compared to the collection of conventional products (Abdelkader & Salem, 2013). This lack of Islamic products is due to the critical constraints faced by the IMFIs, such as the distribution channels, resources, and outreach (Samad, 2014). It is thus essential that IMFIs improve their resources and delivery mechanisms, get to know their customers better, and earn government support for its regulation to grow and survive in the industry. Ahmed (2002) argued that the growth and sustainability of IMFIs largely depend on the availability of external funds and their efficient operations. He added that IMFIs could operate efficiently if the training of employees done regularly to acquire and hone relevant skills (Ahmed, 2002). There is a need for Islamic-oriented training courses in IMFIs.

2.2 Intellectual capital (IC)

IC represents the soft assets of organizations that contribute to the enhancement of the organization's performance. In the current knowledge-based economy, IMFIs provide services to customers and consider intangible assets dynamic resources for the success of the institutions compared to agricultural-based and industrial-based economies that concentrate only on tangible assets. IC is reflected as the heart of a knowledge-based economy (Khaliq, Shaari, Isa, & Samad, 2013). Although intellectual comes from the word intellect (meaning pure intellect), the founder of IC, John Kenneth Galbraith (1969), presumed it a degree of intellectual action. IC is defined as "knowledge that can be converted into profits" (Sullivan, 2000). Edvinsson and Malone (1997) defined IC as knowledge, which can be converted into value. The definition proposes that the management of knowledge (the sum of what is known) creates IC.

2.2.1 Human capital

Human resources are the most valuable assets in any business; however, companies consider it the most neglected asset. Consequently, depending on how managers treat their employees could be a valued asset or liability to a company (Khan, Farooq, & Hussain, 2010). Human capital refers to the skills, knowledge, and experience shared by experts or employees that add value to their organizations (Baron, 2011). Researches from different study have empirically tested the relationship between human capital and organizational performance. The evidence exhibits that human capital strongly influence organizations performance (Abdullah & Othman, 2019; Dzenopoljac et al., 2016; Hang Chan, 2009; Molodchik et al., 2019). Subsequently, one of the core dimensions of intellectual capital is human capital (Kianto, Sáenz, & Aramburu, 2017; Sardo et al., 2018). Amrizah and Rashidah (2013) posit that human capital constitutes the skills and knowledge of employees, which is acquired through training and manifests in improving the company's performance. As for IMFIs, they face a lack of professionalism and technical expertise at the senior management level, which creates poor internal control of the environment and poor implementation and formulation of strategies. Ruíz, Gutiérrez, Caro, and Navarro (2017) stated that to improve firm performance, firms need to develop better human capital by ruling out the old routines to make way for the new knowledge.

Therefore, this research study demonstrates that improving the skills and knowledge of IMFI's human capital will improve its customer's demand and upgrade their structural capital. Ling (2012) claimed that to compete in the global market, firms should invest in developing entrepreneurial leadership (human capital) while enhancing the management process (structural capital), and further develop the relationship with other firms (customer capital). Knowledge will have a significant influence on IC and then lead to the development of new technical and organizational competencies, which means that structural capital as a supportive infrastructure of human capital (Shih, Chang, & Lin, 2010). There is a study that empirically has proven a significant positive correlation between human capital and structural capital (Abdullah & Sofian, 2012). Besides, there is also evidences that customer capital interferes with the connection with human capital (Agostini & Nosella, 2017). Therefore, this study focusses on the relationship between human capital knowledge and skills in customer capital. Secondly, this study also emphasizes the relationship between human capital knowledge and skills in structural capital. Subsequently, the hypothesis is:

H1a: Human capital knowledge has a positive influence on customer capital. H1b: Human capital knowledge has a positive influence on structural capital. H1c: Human capital skills has a positive influence on customer capital.

H1d: Human capital skills has a positive influence on structural capital.

2.2.2 Customer capital

Customer capital refers to the relationships between IMFI's and stakeholders (e.g., customers, suppliers, the government, or related industry associations) and others such as brand names, trademarks, and reputation. Customer capital can only be managed, not controlled. Improvement in customer capital involves moving beyond the boundaries of an organization to develop relationships and trust among customers, suppliers, and the surrounding communities (Akpınar & Akdemir, 1999). For IMFI's to remain sustainable in the long run, support from the local community, customers, and suppliers is essential (Prawiranata, 2013). The argument is that customer capital is the stronghold of intellectual capital, and it thoroughly intervenes in the connection between human capital (Agostini & Nosella, 2017). Therefore, besides having a strong financial foundation, IMFI's should build a substantial banker-customer relationship (Prawiranata, 2013). According to Hashim, Osman, and Alhabshi, (2015), customer capital provides the enormous contribution toward organizational performance compared to the other capitals, while Khalique et al. (2015) stated that customer capital significantly contributes to the implementation of SME's in Pakistan. Thus, the hypothesis is:

H2: A positive relationship between exists between customer capital and IMFI's performance.

2.2.3 Structural Capital

Structural capital comprises of models, concepts, computers, systems, and patents that are formed by workforces but retained by the organization (Akpınar & Akdemir, 1999). Likewise, it may also be developed in another place and brought into the organization to improve productivity. Therefore, structural capital relates to the capability of an organization to fulfill its customers' demands. Evidence does suggest that IMFI's with an excellent organizational structure and having skilled workforces provides competent and excellent services that will result in the superior performance of an organization (Amrizah & Nawal, 2013). Conversely, if an organization possesses knowledgeable and skilled employees, but has less effective structural capital, it is believed that the whole IC will not be stretched to its maximum capacity. Previous researches have also agreed that structural capital has a direct influence on the performance of an organization (Djilali, 2012; Ariawan, 2016; Abdulai, 2012 and Biyun, 2015). Moreover, an organization that has an impressive structural capital usually acquires a supportive culture and gives chances to individuals on a trial and error basis.

H3: A positive relationship between exists between structural capital and IMFI's performance.

2.3 Government Support

Rules implemented by the government are called regulations. Their purpose is to ensure a uniform application of the law by those under the government's control. In Malaysia, the government has appointed the central bank to act as their advisor and banker. The central bank of Malaysia, established on January 26, 1959, is also known as BNM. The objective of BNM is to issue currency, regulate the financial institutions of the country, develop the monetary policy, and monitor the credit system. The main challenge faced by MFI's is improving the institution's capacity to sustain its operation and capture a greater outreach. Consequently, governments play a positive role in

the regulation, supervision, design, and process of a comprehensive financial sector (Abdul Rahman & Dean, 2013). Furthermore, government regulations allow MFIs to progressively achieve sustainability in their operations and increase their outreach (Greuning, Gallardo, & Randhawa, 1998). The direct financial support from the government and donors is essential to establish the MFIs. Thus, for IMFIs to be effective, the support should emphasize developing the sustainability and outreach of MFIs. Therefore, the hypothesis is:

H4: A positive relationship between exists between government support and IMFIs performance.

3. METHODOLOGY

3.1 Data Collection

This study only covered active Islamic microfinance institutions in Malaysia. As such, this study has selected target respondents from each of the 15 states in Malaysia. These respondents were identified by using non-probability judgmental sampling. According to Awang (2012), respondents who were suitable to represent their company were selected based on the researcher's decision. The target respondents comprised senior executives, managers, and higher-level management of Islamic microfinance institutions, who were considered knowledgeable on the government's support as well as involved in the internal control and development of the institutions. Five hundred (500) survey questionnaires have been distributed to prospective respondents through email, and only 266 surveys (53.2%) returned and usable for analysis.

3.2 Estimation Technique

A personally administrated survey was employed in this study using a judgmental sampling method. Respondents were selected based on the required characteristics (Awang, 2012). Development of questionnaires to collect data for the research model constructs. The questionnaire consists of four sections, where the first section is intellectual capital (IC) focused on four components, which were human capital, customer capital, structural capital, and social capital. The second section covered government support (GS). The third section is on IMFIs performance (IMFIs). All items in the first, second, and third sections apply the seven Likert scale (ranging from 1 'strongly disagree' and 7 'strongly agree').

Meanwhile, the fourth section was related to the demographic profile. There are two parts under the demographic profile, namely, organization and individual profile. This study uses G-power software to calculate the sample size of the respondents, whereby the minimum sample size required was determined. Since the model had a maximum of three predictors (for the outcome variable of IMFIs performance), the effect size set to medium (0.15), and the required power was 0.80. In the field of social science, the minimum acceptable has developed to 80% (Gefen, Rigdon, & Straub, 2011). As the sample size required was 77, hence data collected was slightly larger than the required number. A total of 266 managers participated in this study. The response rate accounted for 53.2%, which is considered satisfactory (Sekaran & Bougie, 2010). The model in Figure 1 was measured by using Smart PLS 3.2.7, which is based on bootstrapping and path modelling (Khalique et al., 2020). There are two stages in a PLS analysis, measurement model, and structural model (Hair et al., 2016). The assessment of the measurement model requires the measures' reliability and validity, where the validity measures through convergent validity and discriminant validity. Meanwhile, reliability is measured by examining the Composite Reliability (CR). Consequently, structural model testing with 500 re-samples was conducted after the development of the measurement model to analyse the hypothesized relationships between critical success factors and organizational performance.

4. FINDINGS

Out of 500 surveys distributed, 266 surveys (53.2%) were returned and usable. Table 1 shows that most of the respondents held a senior management position (140 or 52.6%), the middle management position 76 (28.6%) respondents, and 50 (18.8%) respondents held a top management position. Of the 266 respondents, 243 (91.4%) were male, and the remaining respondents (8.7%) were female. Most of the respondents are between the age of 26 to 35 years old (120 or 45.1%), 100 respondents (37.6%) are at the age between 36 to 45 years, 30 respondents (11.3%) are 46 to 55 years, 12 respondents (4.5%) are between 20 to 25 years and only 4 (1.5%) respondents are above 56 years old.

Table 1. Respondents' Profile

		Frequen	%
		cy	
Gender	Male	243	91.4
	Female	23	8.7
Age Group	20-25	12	4.5
	26-35	120	45.1
	36-45	100	37.6
	46-55	30	11.3
	Above 56	4	1.5
Designation	Top management	50	18.8
	Senior management	140	52.6
	Middle management	76	28.6
Working experience	1-5	50	18.8
	6-10	120	45.1
	11-15	40	15.0
	Above 15	56	21.1

4.1 Partial Least Square – Structural Equation Modelling (Measurement Model)

This study has fulfilled the confirmatory factor analysis (CFA) before proceeding to the measurement model. Next is to determine the measures' reliability, convergent validity, and discriminant validity. To assess the convergent validity, Hair, Black, Babin, and Anderson (2010) suggested the use of factor loadings while Average Variance Extracted (AVE), and Composite Reliability (CR) could be used to assess convergent validity. As shown in Table 2, most item loadings are higher than 0.7 (significant at $p < 0.01$), all Average Variance Extracted (AVE) exceeded 0.5 (Bagozzi, 1988), and the Composite Reliability (CR) for all the variables are more than 0.7 (Gefen, Straub, & Boudreau, 2000).

Table 2. Discriminant Validity

Construct	Items	Loading	CR	AVE
Human Capital Knowledge	HCK1	0.725	0.854	0.539
	HCK2	0.722		
	HCK3	0.784		
	HCK4	0.708		
	HCK5	0.728		
Human Capital Skills	HCS9	0.774	0.887	0.663
	HCS10	0.842		
	HCS11	0.800		
	HCS12	0.839		
Customer Capital	CC1	0.728	0.928	0.618
	CC2	0.803		
	CC3	0.741		
	CC4	0.824		
	CC5	0.829		
	CC6	0.816		
	CC7	0.741		
	CC8	0.796		
Structural Capital	SC1	0.759	0.944	0.652
	SC2	0.775		
	SC3	0.857		
	SC4	0.868		
	SC5	0.791		
	SC6	0.781		
	SC7	0.786		
	SC8	0.852		
	SC9	0.792		
Government Support	G1	0.873	0.930	0.690
	G2	0.789		
	G3	0.816		
	G4	0.872		
	G5	0.847		
	G6	0.782		
MFI's Performance	MP1	0.799	0.961	0.691
	MP2	0.847		
	MP3	0.835		
	MP4	0.814		
	MP5	0.857		
	MP6	0.835		
	MP7	0.860		
	MP8	0.812		
	MP9	0.810		
	MP10	0.799		
	MP11	0.875		

Besides, this study uses the Heterotrait Monotrait (HTMT) discriminant criterion to validate discriminant validity (Henseler, Ringle, & Sarstedt, 2015). Henseler et al. (2015) posited the correlation value between constructs is less than one shows that discriminant validity is achieved. However, this study has followed a more conservative threshold of 0.85, indicating a more evident difference between the constructs (Clark & Watson, 1995; Kline, 2011). Table 3 presents the correlation estimates for the HTMT evaluations. The correlation value between the constructs was less than 0.85, hence, confirming that the discriminant validity was met via the HTMT assessment.

Table 3. Heterotrait Monotrait (HTMT)

Constructs	CC	GS	HC K	HCS	MP	SC
Customer Capital (CC)						
Government Support (GS)	0.59					
	6					
Human Capital Knowledge (HCK)	0.80	0.58				
	3	3				
Human Capital Skills (HCS)	0.75	0.45	0.82			
	0	6	2			
MFI Perf (MP)	0.69	0.67	0.63	0.581		
	9	3	4			
Structural Capital (SC)	0.82	0.63	0.73	0.625	0.75	
	2	4	5		1	

4.2 Partial Least Square – Structural Equation Modelling (Structural Model)

The R-squared (R^2) of the endogenous variable was used to explain variance. According to Sandin, Sanchez-Arribas, Chorot, and Valiente (2015), the R^2 value above 0.60 is high, between the range of 0.30 to 0.60 is moderate, and less than 0.30 is low. The R^2 generated in Figure 1 shows that all the exogenous variables (CC, SC, and GS) were capable of explaining 59.7% of the IMFIs performance. Meanwhile, human capital knowledge (HCK) and human capital skills (HCS) were qualified to explain 54.5% and 43.5% of customer capital and structural capital, respectively.

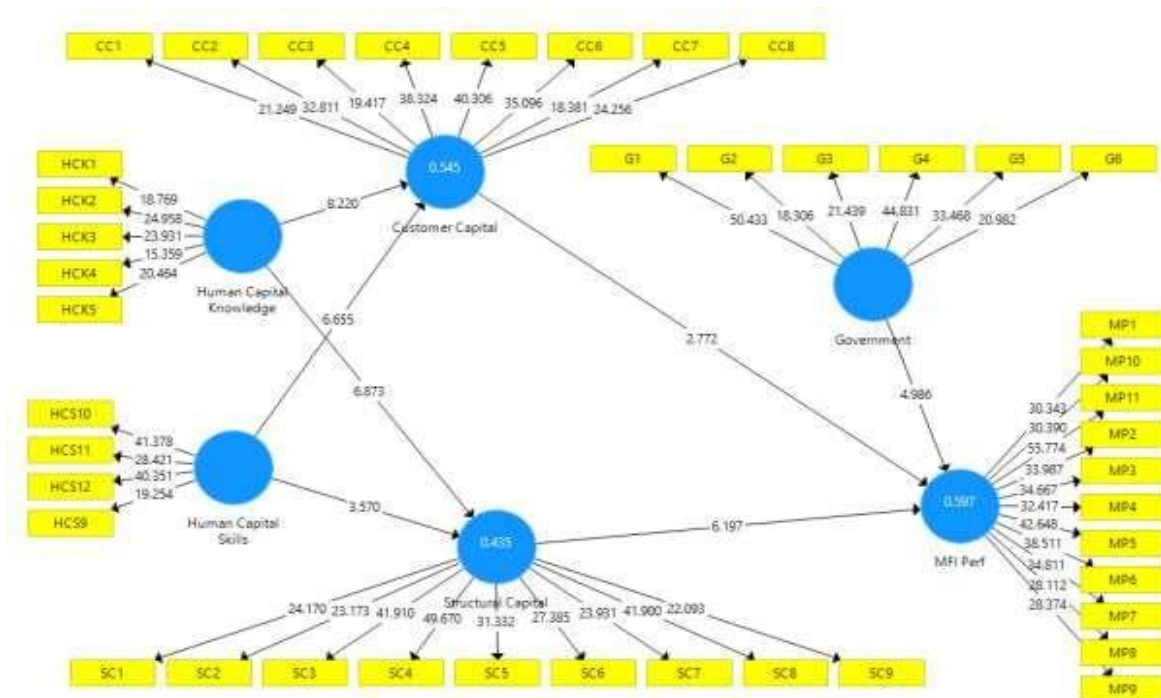

Figure 1. Theoretical framework

The results of the hypothesis testing shown in Table 4, which outlines the path coefficients, observed t-statistics, and significance levels for all the hypothesized paths. According to past works done by Hair, Sarstedt, Hopkins, and Kuppelwieser (2014) and Henseler, Ringle, and Sinkovics (2009), the acceptable t-values to ascertain the significance level in the one-tailed test are 1.28 (10% significance level at $p < .10$), 1.645 (5% significance level at $p < .05$), and 2.306 (1% significance level at $p < .01$).

$p < .05$), and 2.33 (1% significance level at $p < .01$). Based on the result of this study, all the hypotheses shown a significant positive relationship with endogenous variables. From the perspective of IMFIs performance as endogenous variable, CC ($\beta = 0.199$, $t = 2.772$, $p < .01$), SC ($\beta = 0.387$, $t = 6.197$, $p < .01$) and GS ($\beta = 0.298$, $t = 4.986$, $p < .01$) show positive and significant relationships with IMFIs performance. As a result, H2 (CC has a significant positive influence on IMFIs performance), H3 (SC has a significant positive influence on IMFIs performance), and H4 (GS has a significant positive influence on IMFIs performance) are supported. Likewise, for customer capital and structural capital as endogenous variables, HCK ($\beta = 0.432$, $t = 8.220$, $p < .01$) and HCS ($\beta = 0.376$, $t = 6.655$, $p < .01$) has positive significant influence on customer capital and HCK ($\beta = 0.468$, $t = 6.873$, $p < .01$) and HCS ($\beta = 0.247$, $t = 3.570$, $p < .01$) has positive significant influence on structural capital. As a result, H1a and H1c (HCK and HCS have a significant positive influence on customer capital). Also, H1b and H1d (HCK and HCS have a significant positive influence on structural capital) are supported.

Table 4. Path Coefficient and Hypothesis Testing

Hypothesis	Relationship	Std Beta	Std Error	T Values	P Values	LL	UL	Result
H1a	Human Capital Knowledge_ -> Customer Capital	0.432	0.053	8.220	0.000	0.345	0.525	Supported
H1b	Human Capital Knowledge_ -> Structural Capital	0.468	0.068	6.873	0.000	0.350	0.568	Supported
H1c	Human Capital Skills -> Customer Capital	0.376	0.057	6.655	0.000	0.283	0.468	Supported
H1d	Human Capital Skills -> Structural Capital	0.247	0.069	3.570	0.000	0.145	0.370	Supported
H2	Customer Capital -> IMFI Perf	0.199	0.072	2.772	0.003	0.073	0.307	Supported
H3	Structural Capital -> IMFI Perf	0.387	0.062	6.197	0.000	0.287	0.489	Supported
H4	Government Support -> IMFI Perf	0.298	0.060	4.986	0.000	0.205	0.401	Supported Perf

Table 5 illustrates that the mediating effect is examined using a t-test with pooled standard errors. According to Henseler (2016), this is a parametric approach method. The findings suggested that customer capital (CC) mediates the relationship between human capital knowledge (HCK) and skills (HCS) on IMFIs performance. Furthermore, the findings confirmed that structural capital (SC) also mediates the relationship between human capital knowledge (HCK) and skills (HCS) on IMFIs performance. Overall, it shows that customer and structural capital requires the knowledge and skills of human capital in managing the operations and improve the performance of IMFIs. Therefore, H5 (CC mediates the relationship between HCK and IMFIs performance) H6 (CC mediates the relationship between HCS and IMFIs performance) H7 (SC mediates the relationship between HCK and IMFIs performance) H8 (SC mediates the relationship between HCS and IMFIs performance) were supported.

Table 5. Mediator Effect

Hypothesis	Relationship	Beta	Std Error	T Values	P Values	LL	UL	Result
H5	Human Capital Knowledge_ -> Customer Capital -> IMFI Perf	0.086	0.035	2.486	0.007	0.031	0.145	Mediate
H6	Human Capital Skills -> Customer Capital -> IMFI Perf	0.075	0.029	2.612	0.005	0.030	0.121	Mediate
H7	Human Capital Knowledge_ -> Structural Capital -> IMFI Perf	0.181	0.035	5.157	0.000	0.129	0.244	Mediate
H8	Human Capital Skills -> Structural Capital -> IMFI Perf	0.096	0.034	2.807	0.003	0.050	0.159	Mediate

5. CONCLUSION

This study has met its research objective in considering the role of IC components and government support on the performance of IMFIs in Malaysia. Therefore, the results are derived from the entire process of conducting this study. Several studies have revealed that IC components used to measure the performance of organizations

(Khalique et al., 2020; Muchran, 2020; Abdullah & Othman, 2019; Molodchik et al., 2019; Bontis et al., 2000; Halim, 2010; Hashim, Osman, & Alhabshi, 2015; and Kamaluddin & Rahman, 2013). IC, consisting of human capital, customer capital, and structural capital, is a factor of production and an essential asset in a company's value creation process, which allows it to compete successfully (Sharabati, Jawad, & Bontis, 2010). Moreover, IC has been tested empirically to have a highly significant impact on the performance of Islamic microfinance institutions in Malaysia (Hashim et al., 2015). The full utilization of IC by an organization will tend to improve their profitability and productivity (Ariawan et al., 2016). Many studies support the direct connection between government support and the organization's performance (Abdullah & Sofian, 2012; Hubka & Zaidi, 2005; Ngah & Ibrahim, 2009; Purkayastha, Tripathy, & Das, 2014).

The current finding is consistent with the results of a study by Khalique et al. (2015), who stated that organizations require strong coordination and linkages with the government for their development. According to Skaggs and Mark (2004), human capital skills expect to handle complications in the working environment of an organization. Also, Shih et al. (2010) indicated that structural capital mainly provides an environment that supports institutions to invest in their human capital to create and leverage its knowledge to enhance organizational performance. However, it is challenging to obtain creative and innovative employees who can share their potential capability with the IMFIs to produce an effective internal communication system. Bontis et al. (2000) argued that it is a more significant challenge for the service industries to control the employees' skills and codified their capability into an effective information system. The evidence from this study suggests that IMFIs should mobilize their knowledgeable, experienced, and skilled employees to build networks with clients to enable easy access to the microfinance program. In the long run, employees should be encouraged to improve their practical skills, learning, and experience toward social interactions for the efficient and sustainable development of IMFIs performance. It is, therefore, crucial that IMFIs encourage employees to gain sufficient practical skills, learning, and experience to ensure efficient and sustainable development of its human capital to improve performance. Managers should promote an appropriate training program to help employees to forget old habits and learn new knowledge. By making them attend meetings, conferences, and fairs, encouraging them to work together in teams, making them participate in projects and perform different critical jobs, and making them responsible for collecting suggestions internally. These methods would develop the organization's human capital to achieve better performance (Aledo Ruíz et al., 2017). To boost the performance of IMFIs, managers should use a suitable IC blend with the support of the government to increase institutions' performance. Since the results of this study clearly showed that human capital with existing knowledge and skills about their work was the most important intellectual resource, IMFIs should take the initiative to source competent people or build the capacity of the employees that play critical roles in the industry. In effect, the microfinance firm's staff selection system should place greater emphasis on social competence, employee motivation, employee agility, and leadership abilities of staff, instead of their professional competence. Finally, to conclude that IMFIs should have a balance in managing their human capital knowledge and skills, structural capital, and customer capital, including support from the government, will perform better in terms of financial and market performance.

REFERENCES

- Abate, G. T., Borzaga, C., & Getnet, K. (2014). Cost efficiency and outreach of microfinance institutions in Ethiopia: Do they contrast with financial cooperatives? SSRN Electronic Journal.
- Abdullah, N.N. and Othman, M.B. (2019), "Examining the effects of intellectual capital on the performance of Malaysian food and beverage small and medium-sized enterprises", *Technology (IJCIET)*, Vol. 10 No. 2, pp. 135-143
- Adnan, N. S., Kamaluddin, A., & Kasim, N. (2014). Intellectual Capital in Religious Organisations: Malaysian Zakat Institutions Perspective. Accounting Research Institute, 16(June), 2013–2014. <https://doi.org/10.5829/idosi.mejsr.2013.16.03.11092>
- Agostini, L., & Nosella, A. (2017). Enhancing radical innovation performance through intellectual capital components. *Journal of Intellectual Capital*, 18(4), 789-806.
- Ahmed, F., Brown, B., & Williams, S. P. (2013). Is it time to regulate microfinance? *Progress in Development Studies*, 13(3), 209–220. <https://doi.org/10.1177/1464993413486546>
- Ahmed, H. (2002). Financing Microenterprises: An Analytical Study of Islamic Microfinance Institutions. *Islamic Economic Studies*, 9, 27–64. Retrieved from http://www.isdb.org/irj/go/km/docs/documents/IDBDevelopments/Internet/English/IRTI/CM/downloads/IES_Articles/Vol_9-2
- Akpinar, A. T., & Akdemir, A. (1999). Intellectual capital. In *Third European Conference* (pp. 332–340).
- Al-Shami, S. S. A., Majid, I. B. A., Rashid, N. A., & Hamid, M. S. R. B. A. (2013). Conceptual Framework: The Role of Microfinance on the Wellbeing of Poor People Cases Studies from Malaysia and Yemen. *Asian Social Science*, 10(1), 230–242. <https://doi.org/10.5539/ass.v10n1p230>
- Awang, Z., Asyraf, A., & Asri, M. (2015). Parametric and Non-Parametric Approach in Structural Equation Modeling (SEM): The Application of Bootstrapping. *Modern Applied Science*, 9(9), 58–67.
- Bagozzi, R. R. (1988). On the Evaluation of Structural Equation Models, I ~ LI, 16(1).
- Barney, J.B. (1991). Firm Resources and Sustained Competitive Advantage. *Journal of Management*. <https://doi.org/10.1177/014920639101700108>
- Baron, A. (2011). Measuring human capital. *Strategic HR Review*, 10(2), 30–35. <https://doi.org/10.1108/14754391111108338>
- Bontis, N., Keow, W. C. C., & Richardson, S. (2000). Intellectual capital and business performance in Malaysian industries. *Journal of*

- Intellectual Capital, 1(1), 85–100. <https://doi.org/10.1108/14691930010324188>
- Bontis, N., Keow, W., & Richardson, S. (2000). Intellectual Capital and Business Performance in Malaysian Industry. *Journal of Intellectual Capital*, 1, 85-100.
- Chen, M.-C., Cheng, S.-J., & Hwang, Y. (2005). An empirical investigation of the relationship between intellectual capital and firms' market value and financial performance. *Journal of Intellectual Capital*, 6(2), 159–176. <https://doi.org/10.1108/14691930510592771>
- Chin, W. W. (2010). How to Write Up and Report PLS Analyses. <https://doi.org/10.1007/978-3-540-32827-8>
- Clark, L. A., & Watson, D. (1995). Constructing validity: basic issues in objective scale development. *Psychological Assessment*, 7(3), 309–319.
- Dženopoljac, V., Janošević, S. and Bontis, N. (2016), “Intellectual capital and financial performance in the Serbian ICT industry”, *Journal of Intellectual Capital*, Vol. 17 No. 2, pp. 373-396.
- Edvinsson, L., & Malone, M. S. (1997). *Intellectual capital: Realizing your company's true value by finding its hidden brainpower*. New York, NY: U.S.A., *Harper Business Publisher*.
- Galbreath, J. T. (2004). *Determinants of Firm Success: A Resource-Based Analysis*.
- Gefen, D., Rigdon, E. E., & Straub, D. (2011). An Update and Extension to SEM Guidelines for Administrative and Social Science Research. *MIS Quarterly*, 35(2), A1–A7. <https://doi.org/10.1016/j.lrp.2013.01.001>
- Gefen, D., Straub, D. W., & Boudreau, M.-C. (2000). Structural Equation Modeling and Regression: Guidelines for Research Practice. *Communication for the Association for Information Systems*, 4(7), 79.
- Halim, H.A., Ahmad, N.H., Ramayah, T. and Hanifah, H. (2014), “The growth of innovative performance among SMEs: leveraging on organisational culture and innovative human capital”, *Journal of Small Business and Entrepreneurship Development*, Vol. 2 No. 1, pp. 107-125.
- Hair, J.F. Jr, Hult, G.T.M., Ringle, C. and Sarstedt, M. (2016), *A Primer on Partial Least Squares Structural Equation Modeling (PLS-SEM)*, Sage Publications, Thousand Oaks, California.
- Hair, J. F., Black, W. C., Babin, B. J., & Anderson, R. E. (2010). *Multivariate Data Analysis (7th edition)*. Pearson.
- Hair, J. F., Sarstedt, M., Hopkins, L., & Kuppelwieser, V. G. (2014). Partial least squares structural equation modeling (PLS-SEM). *European Business Review*, 26(2), 106–121. <https://doi.org/10.1108/EBR-10-2013-0128>
- Hang Chan, K. (2009), “Impact of intellectual capital on organisational performance: an empirical study of companies in the Hang Seng Index”, *The Learning Organization*, Vol. 16 No. 1, pp. 4-21.
- Hashim, M.J., Osman, I. and Alhabshi, S.M. (2015), “Effect of intellectual capital on organizational performance”, *Procedia-Social and Behavioral Sciences*, Vol. 211, pp. 207-214.
- Henry, L. and Watkins, D. (2013), “Intellectual capital in developing micro-states: the case of Caribbean SMEs”, paper presented at the *Proceedings of the 5th European Conference on Intellectual Capital 2013*
- Henseler, J., Ringle, C. M., & Sarstedt, M. (2015). A new criterion for assessing discriminant validity in variance-based structural equation modeling, 115–135. <https://doi.org/10.1007/s11747-014-0403-8>
- Henseler, J., Ringle, C. M., & Sinkovics, R. R. (2009). *The use of Partial Least Square Path modeling in international Marketing*. *New Challenges to International Marketing: Advances in International Marketing*, 20, 277–319. [https://doi.org/10.1108/S1474-7979\(2009\)0000020014](https://doi.org/10.1108/S1474-7979(2009)0000020014)
- Hisrich, R. D., & Peters, M. P. (2008). *Entrepreneurship*. McGraw-Hill Singapore.
- Holsapple, C. W., & Joshi, K. D. (2001). *Organizational knowledge resources*. *Decision Support Systems*, 35, 39–54.
- Hossain, M. T. (2012). Human Resource Management Practices and Employees' Satisfaction Towards Private Banking Sector in Bangladesh. *International Review of Management and Marketing*, 2(1), 52–58.
- Inkinen, H. (2015), “Review of empirical research on intellectual capital and firm performance”, *Journal of Intellectual Capital*, Vol. 16 No. 3, pp. 518-565.
- Jenkins, W. (2003). *Sustainability theory*. *Encyclopedia of Sustainability*, 380–384. Kahaso, T. N. (2012). The Key Success Factors for Microfinance Industry In MOMBASA.
- Kamaluddin, A., & Kasim, N. (2013). The Relationship between Human Resource Management and Islamic Microfinance Providers' Performance: The Mediating Role of Human Capital. *International Journal of Business and Social Science*, 4(16), 52–57. Retrieved from http://ijbssnet.com/journals/Vol_4_No_16_December_2013/5.pdf
- Kamaluddin, A., & Rahman, R. A. (2013). Intellectual Capital Profiles: Empirical Evidence of Malaysian Companies. *International Review of Business Research Papers*, 9(6), 83–101. Retrieved from <http://search.ebscohost.com/login.aspx>
- Khalique, M. Hina, K., Ramayah, T., & Shaari, J. A. N. (2020). Intellectual capital in tourism SMEs in Azad Jammu and Kashmir, Pakistan. *Journal of Intellectual Capital* Vol. 21 No. 3, 2020 pp. 333-355. Emerald Publishing Limited 1469-1930. <https://doi.org/10.1108/JIC-11-2018-0206>
- Khalique, M., Bontis, N., Abdul, J., Abu, S., & Isa, H. (2015). Intellectual capital in small and medium enterprises in Pakistan. *Journal of Intellectual Capital*, 16(1), 224–238.
- Khalique, M. and Pablos, P.O.d. (2015), “Intellectual capital and performance of electrical and electronics SMEs in Malaysia”, *International Journal of Learning and Intellectual Capital*, Vol. 12 No. 3, pp. 251-269.
- Khalique, M., Shaari, J. A. N. b., Isa, A. H. b. M., & Samad, N. B. (2013). Impact of Intellectual Capital on the Organizational Performance of Islamic Banking Sector in Malaysia. *Asian Journal of Finance & Accounting*, 5(2), 75. doi:10.5296/ajfa.v5i2.4005.
- Khalique, M., Shaari, J. A. N. Bin, Isa, A. H. B. M., & Samad, N. B. (2013). Impact of Intellectual Capital on the Organizational Performance of Islamic Banking Sector in Malaysia. *Asian Journal of Finance & Accounting*, 5(2), 75. <https://doi.org/10.5296/ajfa.v5i2.4005>
- Khan, B., Farooq, A., & Hussain, Z. (2010). Human resource management: an Islamic perspective. *Asia-Pacific Journal of Business Administration*, 2(1), 17–34. <https://doi.org/10.1108/17574321011037558>
- Kline, R. B. (2011). *Principles and practice of structural equation modeling*. New York: Guilford Press. New York: Guilford Press.
- Ling, Y. (2012). A Study on the Influence of Intellectual Capital and Intellectual Capital Complementarity on Global Initiatives. *The Electronic Journal of Knowledge Management*, 10(2), 154–162. <https://doi.org/10.1108/03055721211207806>
- Mokhtar, S. H. (2011). Microfinance performance in Malaysia. Lincoln University. Retrieved from <http://researcharchive.lincoln.ac.nz/handle/10182/4186>
- Molodchik, M.A., Jardon, C.M. and Bykova, A.A. (2019), “The performance effect of intellectual capital in the Russian context: industry vs company level”, *Journal of Intellectual Capital*, Vol. 20 No. 3, pp. 335-354.
- Muchran. (2020). Effect of Intellectual Capital on Sustainable Financial Performance of Indonesian Pharmaceutical Firms with Moderating Role Knowledge Management. *Systematic Review Pharmacy*, Vol 11, Issue 1, Jan-June, 2020
- Muhammad, N. M. N., & Ismail, M. K. A. (2009). Intellectual Capital Efficiency and Firm's Performance: Study on Malaysian Financial Sectors. *International Journal of Economics and Finance*, 1(2), 206–212.

- Nawai, N., & Shariff, M. N. M. (2012). Factors Affecting Repayment Performance in Microfinance Programs in Malaysia. *Procedia - Social and Behavioral Sciences*, 62, 806–811. <https://doi.org/10.1016/j.sbspro.2012.09.136>
- Nimtrakoon, S. (2014). The Relationship Between Intellectual Capital, Firms' Market Value and Financial Performance: Empirical Evidence from Asian Countries.
- Prawiranata, I. R. (2013). *Sustainable Microfinance in Indonesia: A Sociocultural Approach*. Victoria University.
- Roos, J., Roos, G., Edvinsson, L., & Dragonetti, N. C. (1997). *Intellectual Capital Navigating in the New Business Landscape*. Macmillan Business.
- Sandin, B., Sanchez-Arribas, C., Chorot, P., & Valiente, R. M. (2015). Anxiety sensitivity, catastrophic misinterpretations and panic self-efficacy in the prediction of panic disorder severity: Towards a tripartite cognitive model of panic disorder. *Behaviour Research and Therapy*, 67, 30–40.
- Sardo, F., Serrasqueiro, Z. and Alves, H. (2018), "On the relationship between intellectual capital and financial performance: a panel data analysis on SME hotels", *International Journal of Hospitality Management*, Vol. 75 No. 2, pp. 67-74.
- Sekaran, U., & Bougie, R. (2010). *Research Methods for Business A Skill-Building Approach* (Fifth Edit). John Wiley and Sons Ltd.
- Sharabati, A.-A. A., Naji Jawad, S., & Bontis, N. (2010). Intellectual capital and business performance in the pharmaceutical sector of Jordan. *Management decision*, 48(1), 105-131.
- Tenenhaus, M., & Esposito, V. (2005). PLS path modeling, 48, 159–205. <https://doi.org/10.1016/j.csda.2004.03.005>
- Tuyon, J., & Alfonso, A. (2012). Analysis of Microfinance Institutions Lending and Credit Assessment Mechanism in East Malaysia. In *International Conference on Management, Economics and Finance (ICMEF 2012) Proceedings* (p. 20). Retrieved from http://www.globalresearch.com.my/proceeding/icmf2012_proceeding/034_196_ICMEF2012_Proceeding_PG0463_0482.pdf
- Ulum, I. (2007). Pengaruh Intellectual Capital Terhadap Kinerja Keuangan Perusahaan Perbankan. Universitas Diponegoro Semarang. <https://doi.org/10.1108/14691930010324188>
- Wetzels, M., Odekerken-Schröder, G., & Oppen, C. van. (2009). Using PLS Path Modeling for Assessing Hierarchical Construct Models: Guidelines and Empirical Illustration. *MIS Quarterly*, 33(1), 177–195. <https://doi.org/Article>
- Zehri, C., Abdelbaki, A., & Bouabdellah, N. (2012). How Intellectual Capital Affects A Firm's Performance? *Australian Journal of Business and Management Research*, 2(06), 32–39.
- Zia, M., Muhammad, H., Arbab, S., Shahzad, A., & Bilal, S. (2014). VAIC and Firm Performance: Banking Sector of Pakistan. *Information and Knowledge Management*, 3(4), 100–107

AL-HAJIYAT DALAM PERLAKSANAKAN INSTRUMEN AL-TAWRIQ UNTUK PEMBANGUNAN ASET WAKAF

Asikin Razak & Fuadah Johari

Fakulti Ekonomi dan Muamalah Universiti Sains Islam Malaysia (USIM), Malaysia

Abstrak

Kajian ini bertujuan untuk mengkaji pembahagian Maqasid Syariah (al-Hajiyat) dalam pelaksanaan instrumen al-Tawriq untuk pembangunan aset wakaf. Kajian kualitatif telah digunakan dalam penyelidikan ini. Ia mengkaji literatur dan sesi temubual sebagai pengumpulan data deskriptif. Sebilangan besar pengurus wakaf di setiap negeri pada umumnya menghadapi kesulitan dalam mengembangkan aset wakaf dan mereka menghadapi masalah kewangan untuk mengembangkan aset wakaf. Instrumen Al-Tawriq adalah kaedah mencairkan aset wakaf untuk tujuan pembangunan harta wakaf. Dengan itu dapat memaksimumkan manfaat setiap aset wakaf dan memudahkan pengurus wakaf menangani isu berkaitan aset wakaf. Oleh itu, instrumen al-Tawriq dapat memenuhi syarat-syarat Maqasid Syariah al-Hajiyat kerana instrumen ini telah menjadi syarat penting untuk kesejahteraan aset wakaf. Penyelidikan konseptual ini menjadi suatu keperluan dan potensi instrumen al-Tawriq tanpa membincangkan perincian operasi dan perundangan serta memfokuskan bahagian al-Hajiyat dalam Maqasid Syariah. Organisasi wakaf harus menggunakan kemampuan instrumen al-Tawriq dan mempraktikkannya untuk mengembangkan aset wakaf terbiar sambil memberikan banyak faedah kepada masyarakat sosial yang disasarkan. Justeru, pengembangan aset wakaf melalui kaedah al-Tawriq suatu keperluan kepada institusi wakaf termasuk institusi swasta yang menyumbang kepada pembangunan sosio-ekonomi masyarakat.

Keywords: Maqasid Syariah, al-Hajiyat, al-Tawriq Wakaf,

1.0 PENGENALAN

Al-Tawriq adalah suatu instrumen kepada pembangunan harta-harta wakaf yang terbiar. Idea ini telah diilhamkan oleh seorang minda syariah iaitu Dato' Dr. Daud Bakar dalam suatu majlis yang berlangsung di Fakulti Ekonomi dan Muamalah, USIM pada 27 April 2016. Beliau memberi galakan kepada para ahli penyelidik supaya mengembangkan instrumen al-Tawriq ini sebagai salah satu pemudah cara dan suatu solusi untuk membangunkan aset wakaf terbiar (Mohd. Daud Bakar, 2020). Proses al-Tawriq wakaf berlaku dahulu diikuti dengan proses istibdal. Kecairan tunai yang diperoleh hasil daripada aktiviti mencairkan aset wakaf adalah dinamakan instrumen al-Tawriq (Fuadah, 2020). Instrumen al-Tawriq sebenarnya telah lama dipraktikkan dalam pengurusan institusi wakaf sebagai salah satu solusi untuk mendapatkan kecairan dan memperkembangkan aset wakaf sekaligus memberikan manfaat yang maksimum kepada masyarakat terutamanya umat Islam.

Kajian mengenai maqasid syariah dalam mencairkan aset-aset wakaf dengan memfokuskan kepada pembahagian maqasid syariah al-hajiyat sebagai suatu keperluan mempraktikkan instrumen al-Tawriq akan dibincangkan secara lebih lanjut. Kajian ini adalah sebagai satu solusi kepada pengurus wakaf dalam melaksanakan konsep al-Tawriq untuk menyelesaikan masalah aset-aset wakaf terbiar bersandarkan syariah Islamiyah.

Terdapat dua contoh utama yang membabitkan pelaksanaan al-Tawriq bagi tujuan pembangunan aset-aset wakaf ke arah yang lebih produktif. Pertama, aset wakaf yang mempunyai nilai yang rendah dan memberi hasil yang sedikit dijual dan ditukarkan kepada aset wakaf yang lebih tinggi nilainya dan memberi hasil yang banyak kepada masyarakat.

Contohnya kes yang berlaku di Singapura, Majlis Agama Islam Singapura telah menjual 20 unit kedai kepada Fusion Investment bernilai 9 juta dollar Singapura. Kebanyakan unit kedai tersebut adalah harta tanah wakaf yang berada di kawasan yang tidak strategik dan aset berkualiti rendah pada kadar 1% hasil pulangan dan dana yang terkumpul daripada Tawriq wakaf tersebut adalah sebahagian modal kos pembangunan projek yang selebihnya diperolehi daripada sukuk musyarakah sebanyak 25 juta dollar Singapura (Fahrurroji, 2015). Hasil dana terkumpul di istibdalkan kepada pengubah suaian dan baik pulih pembangunan baharu yang lebih berkualiti tinggi dan komersial. Hasil kreativiti dan inovasi MUIS dalam merancang strategi pembangunan wakaf di Singapura telah menyumbang kepada pembentukan sumber pendapatan untuk ma'wquf 'alayh, dan juga berusaha untuk menikmati hasil yang lebih kompetitif di samping nilai harta wakaf juga meningkat (Fahrurroji, 2015)

Contoh yang lain, iaitu projek tanah Wakaf Abdul Kadir yang membabitkan MAINPP dalam penjualan aset hasil dari pembangunan atas tanah wakaf. Hasil penjualan pembangunan tanah wakaf ini dapat memberi dana kepada pembangunan tanah wakaf lain iaitu tanah Wakaf Abdul Kadir. Terdapat 3 kategori pembahagian aset wakaf yang dibangunkan. Pertama, sebahagian daripada 46 unit rumah tersebut digunakan sebagai penempatan semula penduduk yang telah dipindahkan bagi pembangunan semula tanah wakaf tersebut. Kedua, 6 unit adalah untuk sewaan manakala yang ketiga, 100 unit rumah akan dijual kepada orang awam yang beragama Islam (berstatus 'lease hold') (Fuadah, 2019).

Perlaksanaan konsep al-Tawriq dalam pembangunan aset-aset wakaf ini bukan sahaja dapat memberi impak yang positif kepada institusi wakaf bahkan dapat menyelesaikan isu berkaitan aset-aset wakaf yang tidak produktif. Namun, persoalan utama adalah sejauh mana instrumen al-Tawriq ini menjadi suatu keperluan (Al-Hajiyat) berlandaskan maqasid syariah kepada institusi wakaf dalam membangunkan aset-aset wakaf sekaligus memberi kesan yang positif kepada masyarakat.

KONSEP AL-TAWRIQ WAKAF

Al-Tawriq adalah berasal dari kata al-Wariq iaitu menukarkan aset kepada kecairan tunai. Penjualan sebahagian daripada harta wakaf bertujuan untuk menampung kos pengurusan, penyelenggaraan atau pembangunan (Mohd Daud Bakar, 2017). Fuadah Johari (2018) ada menyatakan al-Tawriq mempunyai dua terminology dan definisi iaitu al-Tawriq berasal dari kata waraqa, Awraq al-Mal dan al-Wariq dan memberi makna literal al-Tawriq sebagai sekuriti. Definisi al-Tawriq oleh Ali Mahyudin (tidak bertarikh) berasal dari perkataan waraqa al-syajar, perak berlipat ganda atau tidak berlipat ganda. Namun, dari segi ekonomi, al-Tawriq adalah sekuritisasi, yang bermaksud instrumen undang-undang dan ekonomi moden untuk pengembangan pasaran kewangan dalam ekonomi.

Oleh itu, al-Tawriq dapat ditafsirkan dalam dua keadaan. Yang pertama adalah mencairkan aset untuk mendapatkan wang tunai. Yang kedua adalah pembubaran aset tidak alih (harta tanah) melalui penciptaan hutang / instrumen kewangan baru (sijil) dalamerti memindahkan aset kewangan dari pemberi pinjaman asal kepada yang lain, sebahagian besarnya melalui institusi kewangan, dan bursa saham (Fuadah Johari, 2019). Konsep al-Tawriq seringkali dinggap sama dengan konsep istibdal tetapi sebenarnya proses al-Tawriq berlaku sebelum terjadinya istibdal ke atas tanah wakaf. Al-Tawriq adalah suatu istilah baru yang diperkenalkan bertujuan untuk membangunkan aset-aset wakaf yang tidak produktif dan terbiar sekali gus dapat mempertingkatkan kualiti pengurusan yang baik kepada institusi wakaf dalam menangani isu-isu berkaitan aset wakaf.

Maqasid Syariah

Maqasid adalah berasal dari kata jamak maqsid dan maqsad yang berasal dari perkataan qasada dan di dalam bahasa arab bermaksud menuju kepada sesuatu arah (al-Qazwini, 1986). Maqasid syariah membawa maksud objektif, tujuan, matlamat agama dan kehendak menjadikan jalan yang lurus dan jelas yang datang dari Allah yang berbentuk hukum berkaitan ibadat, akidah, munakahat, jenayat, muamalat, politik dan sosial yang menjadikan punca kepada sesuatu kehidupan (Mahmud Shaltut, 2007). Setiap apa yang diciptakan Allah mempunyai tujuan dan hikmahnya dan mustahil bagi Allah menjadikan sesuatu perkara tanpa matlamat dan tujuan (Nor Muhamad et al., 2015).

Menurut pengertian syara' maqasid syariah adalah tujuan dan makna yang dikehendaki oleh syara' di dalam mensyariatkan sesuatu hukum untuk mencapai kemaslahatan umat manusia (Ramli et al., 2016). Menurut Muahammad Abdul 'Ati maqasid syariah terbahagi kepada tiga jenis, pertama adalah maqasid am, kedua adalah maqasid khas dan ketiga adalah maqasid juz'iah (separa). Beliau menjelaskan bahawa maqasid 'ammah adalah tujuan yang memenuhi syariat dan berusaha untuk mencapainya di semua atau sebahagian perundangan Islam. Beliau menyebut dan menerangkan maqasid ammah ini sebagai menarik kebaikan serta menolak keburukan, menurut peraturan, menyamaratakan semua manusia, memperteguhkan umat Islam dan memartabatkan syariah Islam dan sebagainya. Beliau memberi maksud maqasid khas adalah tujuan yang ingin dicapai oleh syariah dalam bab tertentu seperti maqasid syariah dalam hukum kekeluargaan, jual beli harta, dan muamalah yang berkaitan dengan badan-badan (kerja dan pekerja), maqasid kehakiman dan sebagainya. Maqasid khas termasuk dalam pensyariatkan hukum yang berkaitan dengan setiap perilaku manusia seperti al-rahm, mendirikan system kekeluargaan dalam akad perkahwinan dan menolak kemudaratan yang berlaku secara berterusan dalam pensyariatkan talak (Ramli et al., 2016).

Terdapat tiga jenis pembahagian maqasid syariah seperti yang dinyatakan oleh Imam al-Haramyn iaitu al-maqasid al-dhoruriyyah (objektif penting), al-maqasid al-hajiyah (objektif pelengkap) dan al-maqasid al-tahsiiniyyah (objektif hiasan) (Muhamad Ali, 2007). Pengkategorian ini secara tegas diterima dan diterima oleh para ahli hukum Islam dan menjadi tumpuan mereka dalam membincangkan maqasid al-shariah (Awan et al., 2017).

Al-Dhoruriyyah melibatkan semua perkara yang menjadi keperluan asas kepada setiap individu. Ia merupakan suatu kemaslahatan yang wajib dipenuhi untuk mendirikan kemaslahatan dunia dan agama seperti setiap manusia hendaklah memiliki harta untuk menjalani kehidupan seharian dan Allah S.W.T telah menurunkan pensyariatkan berkaitan dengan persoalan menggunakan harta, membelanjakan harta dan pemilikan harta (Nor Muhammad et al., 2015). Sekiranya tidak memenuhi maqasid al-dhoruriyyat kehidupan manusia akan menjadi terancam baik di dunia ataupun di akhirat (Mustofa, 2017). Di dalam maqasid al-Dhoruriyyat terdapat lima perkara penting iaitu memelihara agama, diri, akal, keturunan dan harta (Nor Muhammad et al., 2015).

Al-Hajiyat adalah maslahat yang sekunder yang sangat diperlukan oleh manusia untuk memudahkan kehidupan dan menngangkat kesulitan dan kesempitan sekiranya tidak ada, akan ada kesusahan dan kesulitan, yang implikasinya tidak menghancurkan kehidupan (Shidiq, 2020). Maslahat al-Hajiyat berkait dengan perkara-perkara ibadah, adat, muamalat dan jenayah (Sa'id Azhar, 2010).

Al-Tahsiniyyah merupakan maslahat yang penting yang dituntut kepada manusia seperti menjaga adat-adat yang baik dan budi pekerti yang mulia (Yusuf, pemakaian maqasid). Sekiranya ia tidak ada tidak akan membawa kehancuran kepada hidup manusia seperti yang berlaku kepada al-Dhoruriyyat dan tidak pula membawa kepada kesukaran hidup seperti yang berlaku kepada al-Hajiyat.

Al-Tawriq Wakaf Dalam Melestarikan Maqasid Al-Hajiyat

Dalam konteks wakaf, keseluruhan pengurusan wakaf harus mempertimbangkan maqasid wakaf. Maqasid wakaf merujuk kepada tujuan utama wakaf adalah melakukan amal soleh demi Allah SWT (Mahmud & Shah, 2010). Pembahagian maqasid terbahagi kepada tiga bahagian berdasarkan urutan kekuatannya seperti al-daruriyyat, al-hajiyat dan al-tahsiniyyat di samping pelengkapannya (mukammilat) (Ramli et al., 2016). Wakaf juga memainkan peranan penting dalam memelihara daruriyyat, hajiyat dan tahsiniyyat (Arshad et al., 2018).

Selain itu, maqasid al-syariah menjadi parameter dalam merancang jalan keluar untuk menyelesaikan setiap masalah wakaf (A wang et al., 2017). Maqasid al-Hajiyat bertujuan untuk memberi kesenangan dan mengelakkan kesusahan kepada masyarakat. Harta wakaf harus dipelihara dan dikembangkan untuk memenuhi hasrat pewakaf iaitu untuk mendapat ganjaran pahala dari Allah S.W.T. Abu Ishak Al-Syatibi ada menyebut tentang penerangan al-hajiyat dalam buku beliau Al-Muwafaqat Fi Usul al-Syariah, bahawa al-hajiyat adalah kepentingan yang diperlukan oleh manusia untuk memberi kemudahan dan mengangkat kesukaran kepada masyarakat.

Al-Tawriq wakaf memberi kemudahan kepada pengurus wakaf terutamanya dalam menangani masalah wakaf. Namun, dalam keadaan yang luar biasa atau demi kepentingan pembangunan wakaf yang adil atau keadilan social, pihak pengurus wakaf seharusnya melihat secara lebih wakaf juga terlibat secara tidak langsung dalam proses untuk mencapai al-Maqasid al-Hajiyat. Sebagai contoh, para ahli hukum Islam bersetuju bahawa al-ijarah (pajakan Islam) diatur dan dibenarkan oleh Syariah untuk mencapai al-maqasid al-hajiyah (A wang et al., 2017).

Pandangan Para Imam Muktabar Mengenai Al-Tawriq Wakaf

Prinsip wakaf pada asalnya tidak boleh di jual, di warisi dan dihibahkan seterusnya terputus pemilikan harta kepada pewakaf. Walaupun aset wakaf perlu dipertahankan sebagaimana prinsip asal wakaf berdasarkan hadis Baginda Nabi Muhammad, al-Tawriq wakaf dibenarkan berdasarkan ijtihad para Qadi dan panel penasihat syariah (Fuadah et al., 2018) . Namun begitu terdapat beberapa keadaan yang mengharuskan wakaf dijual seperti aset wakaf tersebut tidak lagi berfungsi dengan baik dan tidak akan mendatangkan manfaat kepada umat manusia.

Seperti yang dinyatakan dalam perbincangan di atas, instrumen al-Tawriq adalah suatu proses yang akan berlaku sebelum berlakunya proses istibdal yang mana proses al-Tawriq adalah suatu proses menukarkan suatu aset wakaf kepada kecairan tunai, manakala istibdal berlaku selepas itu apabila kecairan yang diperolehi akan dibeli suatu aset wakaf yang lain bagi menggantikan aset wakaf yang lama. Pendapat para ulamak berkaitan al-Tawriq iaitu menukarkan adalah lebih kurang sama dengan pendapat para ulamak mengenai istibdal.

Para ulamak bersependapat bahawa aset-aset wakaf yang tidak melibatkan masjid dibolehkan menjual aset tersebut dan tidak menjadi suatu masalah yang besar (Fuadah et al., 2018). Imam Hambali mengharuskan penjualan aset wakaf yang rosak ataupun aset wakaf yang tidak mendatangkan manfaat seperti masjid dan aset wakaf selain masjid (Ibn Qudamah, 1969). Kuda perang yang tidak mampu lagi untuk digunakan ketika berperang dijual dan hasil jualan itu dibeli kuda perang yang lain.

Imam Syafie tidak membenarkan penjualan aset wakaf termasuk aset wakaf bukan masjid tetapi membenarkan

mengubah fungsi aset wakaf dalam bentuk kegunaan yang lain sekiranya fungsi asalnya tidak lagi boleh digunakan (Abu Zahrah, 1972). Di samping itu, Imam Maliki juga membenarkan penjualan aset-aset wakaf yang tidak lagi berfungsi seperti tujuan asal wakaf, dan membenarkan dalam keadaan tiga syarat pertama, pewakaf mensyaratkan agar aset wakaf tersebut dijual, kedua adalah barang yang diwakafkan tidak lagi memenuhi maksud pewakafan termasuklah jenis harta alih dan yang terakhir adalah khas bagi harta yang tidak alih sekiranya di jual mestilah untuk keperluan perluasan jalan, masjid dan perku buran sahaja (Abu Zahrah, 1972).

2.0 SOROTAN LITERATUR

Instrumen al-Tawriq adalah salah satu penyelesaian untuk meningkatkan pembangunan aset-aset wakaf. Kualiti aset wakaf akan meningkat dengan mendapatkan kecairan tunai bagi tujuan pendanaan baru untuk tujuan pembangunan dan perbelanjaan penyelenggaraan (Fuadah et al., 2018). Mutawwali adalah orang yang bertanggungjawab mengembangkan dan membangunkan tanah wakaf supaya masyarakat mendapat manfaat yang berterusan daripada aset-aset wakaf (Mat Hassan, 2018). Aset-aset wakaf perlu ditadbir secara efisien supaya ia lebih produktif dengan menggunakan kaedah yang betul berlandaskan maqasid syariat. Instrumen maqasid syariah adalah salah satu teori seismograf hukum Islam yang menjadi suatu piawaian dalam usaha untuk mendapatkan kebaikan dan menolak semua keburukan serta dapat mengangkat semua kesulitan yang menggugat aktiviti kehidupan manusia (Ramli, n.d.).

Sekiranya kebanyakan tanah wakaf yang belum dibangunkan dapat dibangunkan, Malaysia akan mendapat pulangan yang besar dan ini dapat digunakan untuk pelbagai tujuan yang dimaksudkan seperti untuk penerima wakaf, ekonomi masyarakat Islam, untuk mengekalkan harta wakaf dan juga untuk membiayai wakaf yang lain tanah (Mohd Ali et al., 2015).

3.0 METODOLOGI KAJIAN

Pada peringkat permulaan kajian ini telah merujuk beberapa pendapat dan perbincangan para ilmuwan mengenai isu dan cabaran yang dihadapi oleh pengurus wakaf dalam menangani aset-aset wakaf tidak produktif, halangan yang dihadapi dan maqasid wakaf. Pada peringkat kedua kajian ini menggunakan kaedah kualitatif dengan mengenalpasti pendapat dan kepentingan instrumen al-Tawriq sebagai salah satu solusi kepada aset-aset wakaf yang tidak lagi produktif berdasarkan perspektif pengurus wakaf. Data dikumpulkan melalui temu bual secara separa berstruktur secara langsung dengan pengurus wakaf dari Majlis Agama Islam yang terdiri dari empat buah negeri. Peserta yang ditemu ramah terdiri dari ketua-ketua jabatan wakaf dari Majlis Agama Islam yang terpilih. Semua sesi temu ramah akan dirakan dengan izin peserta dan kemudian ditranskripkan bagi memastikan ketepatan dan kesahihan data tersebut (Perakyla, 1997). Data di analisis menggunakan perisian Atlas.ti 8 dan penemuan dari analisis data temu bual digunakan untuk mengenalpasti instrumen al-Tawriq dapat memenuhi maqasid al-Hajiyat kepada institusi wakaf.

4.0 ANALISIS KAJIAN

Hasil daripada analisis temu bual menunjukkan bahawa pengurus wakaf telah pun mengamalkan konsep al-Tawriq tanpa sedar yang berlaku di bawah projek istibdal. Pengurus wakaf mengamalkan konsep al-Tawriq untuk membangunkan tanah-tanah wakaf yang kurang produktif dan mempunyai nilai komersial yang rendah. Namun ada sebahagian pengurus wakaf bersetuju tentang konsep al-Tawriq dilaksanakan bagi memudahkan urusan membangunkan aset-aset wakaf yang tidak produktif selaras dengan teori maqasid al-hajiyat.

Pengurus wakaf: "Tanah di Sekolah Al-Ibtisam Padang Senai baru ni dia ada tanah lebih kurang dalam 3 relong lebih tetapi tanah berpaya dan memang tidak boleh dibangunkan, nilai untuk menambun balik tanah itu pun tinggi, jadi baruni dia minta supaya untuk jual tanah itu dan nak beli tanah yang dekat dengan sekolah tu, jadi kita dah putus dalam fatwa pun, fatwa pun putus kata setuju untuk kita jual kemudian beli tanah balik di depan tu berhampiran dengan sekolah tu dalam lebih kurang 1 relong tu pun tak sampai kot tapi nilai tinggi tanah tinggillah".

Temu ramah di atas menunjukkan bahawa suatu projek al-Tawriq telah dilaksanakan di Kedah kesan daripada aset wakaf yang tiada potensi untuk dibangunkan dan terletak di kawasan yang bukan "hotspot". Pengurus wakaf mengusulkan cadangan kepada majlis fatwa.

Pengurus wakaf: "Saya faham yg instrumen al-tawriq ni, kita buat satu keputusan utk cairkan dana kita, tapi kita tak buat konsep macam tu, atas permintaan atau kes-kes tertentu, yg ada keperluan baru kita buat, kita panggil istibdal".

Pernyataan di atas menyimpulkan bahawa Al-Tawriq adalah suatu keperluan untuk institusi wakaf dalam membangunkan aset wakaf yang tidak produktif serta mematuhi syariah dalam setiap aspek aktiviti mereka dalam mencapai objektif wakaf.

Gambarajah 1.1 : Al-Tawriq di Kedah

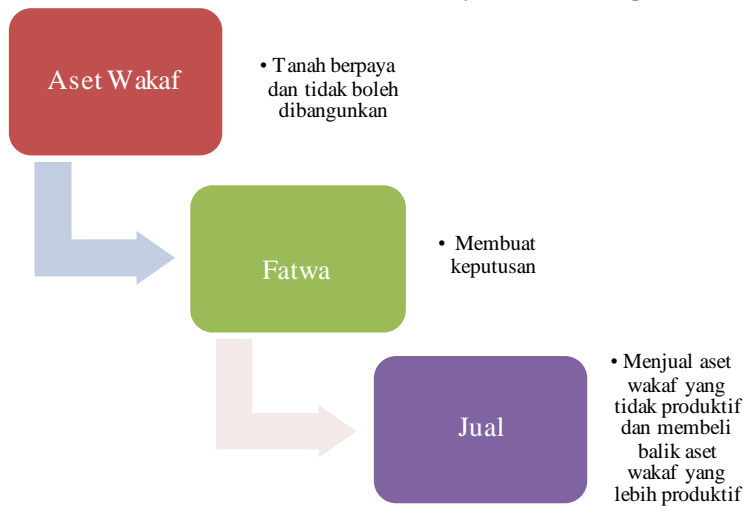

4.1 Maqasid Al-Shariah sebagai Petunjuk dalam Melaksanakan Sesuatu Projek:

Berdasarkan gambarajah 1.1 menunjukkan Keputusan pelaksanaan al-Tawriq bergantung kepada majlis fatwa. Sinonimnya pihak majlis fatwa telah meneliti dan melihat dari sudut pandang maqasid syariah sebelum membuat sesuatu keputusan membenarkan suatu projek dilaksanakan. Wujudnya aset wakaf yang tiada potensi untuk dibangunkan menyebabkan pihak Sekolah al-Ibtisam mengambil keputusan untuk menjual tanah tersebut. Pihak Majlis Agama Islam mengusulkan dan mendapat kelulusan dari pihak majlis fatwa. Proses menjual tanah yang tidak berpotensi berlaku kemudian mendapat kecairan (proses al-Tawriq) hasil dari penjualan aset wakaf kemudiannya membeli satu tanah wakaf yang berada di kawasan yang lebih strategik.

Berdasarkan temubual selanjutnya, pengurus wakaf membentangkan instrumen al-Tawriq yang berlaku di bawah projek istibdal seperti digambarkan dalam jadual 1.2

Jadual 1 : Kecairan (Al-Tawriq Wakaf) dalam pelaksanaan projek Istibdal

No.	Projek	Isu	Al-Tawriq Wakaf	Analisis Maqasid Hajjat
1	Wakaf Zuriat Tok Pelam	Pengambilan tanah wakaf oleh kerajaan untuk membina projek kerajaan. Menjual tanah wakaf kepada kerajaan dan ganti dengan tanah yang lain	Al-Tawriq wakaf berlaku dalam projek istibdal. Kecairan yang dapat hasil dari jualan tanah kepada kerajaan (Al-Tawriq)	Keperluan kepada mencairkan aset wakaf untuk memudahkan projek kerajaan berjalan.
2	Tanah Perkuburan di Darga, Alor Setar	Kedudukan tanah perkuburan yang tidak sesuai, Pemaju membuat kawasan perumahan	Al-Tawriq wakaf berlaku dalam projek istibdal. Kecairan diperoleh hasil dari menjual tanah perkuburan kepada pemaju perumahan.	Keperluan kepada mencairkan aset wakaf kerana kedudukan aset wakaf yang tidak sesuai dan memberi kemudahan kepada pemaju untuk membina kawasan perumahan.
3.	Tanah Wakaf Berhampiran pejabat zakat Kedah	Kedudukan tanah berada di dalam kawasan pejabat zakat, untuk jalan masuk ke pejabat zakat dan pembesaran kawasan pejabat zakat.	Al-Tawriq berlaku dalam projek istibdal. Kecairan diperoleh hasil dari menjual tanah wakaf kepada pejabat zakat Kedah.	Keperluan kepada menjual aset wakaf kerana berada di kawasan yang tidak sesuai dan memudahkan urusan Pejabat Zakat Kedah.
4.	Lapangan Terbang Alor Setar	Tanah wakaf berada di kawasan lapangan terbang	Al-Tawriq berlaku dalam projek istibdal. Kecairan diperoleh hasil dari menjual tanah wakaf kepada lapangan terbang.	Keperluan kepada menjual aset wakaf kepada lapangan terbang dan memudahkan urusan pihak lapangan terbang.

Sumber : Hasil temubual bersama Pengurus Wakaf, pada 16 Disember 2019.

Berdasarkan jadual 1 di atas, elemen maqasid al-hajiyat digunakan di dalam mencairkan aset-aset wakaf yang mempunyai masalah dan isu seperti yang berlaku kepada Wakaf Zuriat Tok Pelam. Pihak majlis agama terpaksa menjual kepada pihak kerajaan untuk membina projek kerajaan. Selain itu, keperluan kepada menggunakan instrumen al-Tawriq kerana kedudukan Tanah Perkuburan di Darga, Alor Setar yang berada di kawasan yang tidak sesuai. Aset wakaf tersebut dicairkan dan kemudiannya diganti kepada tanah yang berada di kawasan yang lebih sesuai. Kemudiannya isu yang berlaku di tanah wakaf yang berhampiran Pejabat Zakat Kedah yang mana keperluan kepada menggunakan instrumen al-Tawriq untuk memudahkan urusan pengurus wakaf. Instrumen al-Tawriq juga digunakan dalam projek istibdal wakaf yang berlaku di Lapangan Terbang Alor Setar. Kedudukan tanah wakaf yang berada di dalam kawasan lapangan terbang terpaksa dicairkan dan kemudian digantikan kepada tanah wakaf yang berada di kawasan lain.

5.0 KESIMPULAN

Penyelidikan ini meneroka teori maqasid al-Hajiyat dalam melaksanakan konsep al-Tawriq bagi tujuan pembangunan aset-aset wakaf. Pengurus wakaf memberikan respon yang positif terhadap pelaksanaan al-Tawriq ke atas tanah-tanah wakaf yang tidak produktif supaya terus diperkembangkan untuk manfaat masyarakat. Setiap projek ke atas aset wakaf mestilah mendapat persetujuan daripada pihak fatwa dengan melihat kepada ilmu maqasid syariah dengan meneliti elemen penjagaan agama, nyawa, akal, keturunan dan harta sesuai dengan keutamaan daruriyat, hajiyat dan tahsinat. Sangat penting untuk memasukkan unsur maqasid syariah dalam pengurusan wakaf kerana wakaf adalah suatu penyerahan kepada Allah S.W.T dan termaktub di dalam al-Quran dan as-Sunnah.

Perlaksanaan pengurusan wakaf seharusnya selari dengan prinsip Islam. Maqasid al-Hajiyat selari dengan pelaksanaan instrumen al-Tawriq dalam memberi kemudahan dan mengangkat kesulitan kepada institusi wakaf dalam menguruskan aset-aset wakaf. Penggabungan maqasid elemen ke atas al-Tawriq wakaf menjadikan alat pengukur yang sesuai untuk membimbing institusi wakaf untuk menjalankan tanggungjawab yang telah diamanahkan kepada mereka. Di samping itu, relevan kepada pengurus wakaf dalam memahami dan membuat penelitian secara mendalam tentang konsep al-Tawriq.

RUJUKAN

- Abu Zahrah. (1972). *Muhadarat fi al-Wakaf*. Darul Fikr Al-Arabi, Kaherah .
- Arshad, R., Zain, N. M., Urus, S. T., & Chakir, A. (2018). Modelling Maqasid Waqf performance measures in Waqf institutions. *Global Journal Al-Thaqafah*, 2018.
- Awang, M. B., Hamid, N. A., Nazli, I., & Lotpi, M. (2017). Maqasidic Approach in the Management of Waqf Property: A Study with Reference to Malaysian Contemporary Issues. *Pertanika J. Soc. Sci. & Hum*, 25, 301–308.
- Fahruroji, F. (2015). *Pengembangan Harta Wakaf di Singapura*. *Jurnal Equilibrium*, 3(1), 105-125.
- Fuadah, J. (2019). *Pelaksanaan Al-Tawriq (kaedah kecairan) ke atas tanah komersial wakaf: kajian kes di Pulau Pinang*. Proceedings of International Conference on Zakat, Tax, Waqf And Economic Development (ZAWED) 2019.
- Fuadah, J., Wan Abdul Fattah, W. I., Muhammad Aunurrochim, M., Hanim, M., Ahmad Syukran, B., & Nurul Asikin, A. R. (2018). Penerokaan Konsep Al-Tawriq Dalam Pencairan Aset Wakaf Exploration of the Concept of al-Tawriq in Waqf Asset Liquidity. *Journal of Fatwa Management and Research*, 2018(Special Edition), 198–214.
- Ibn Faris al-Qazwini, `Ali al-Husain Ahmad. 1986M/1406H. *Mujmal al-Lughah*. Tahqiq Zahir `Abd al-Muhsin Sultan. j. 3. c. 2. Beirut: Muassasah al-Risalah
- Ibn Qudamah, A. I. M. (1969). *Al-Mughni Li Ibn Qudamah*, Juz 6. Maktabah al-Kaherah, Sudan .
- Mahmud Shaltut. 2007M/1428H. *al-Islam `Aqidah wa Syari`ah*. c. 29, Kaherah: Dar alShuruq
- Mat Hassan, S. H. (2018). *Kelestarian Pembangunan Harta Wakaf: Analisis Terhadap Perumahan Wakaf Di Pulau Pinang*. 16.
- Mohd Ali, N., Ahmad, R., & Mahdzan, N. S. A. (2015). The need of an effective business model for waqf land development in Malaysia. *20th International Research Conferences on Business, Economics and Social Sciences*, 1, 1–12.
- Muhamad Ali, M. A. A. (2007). *al-Maqasid as-Syariah Waatharuha Fil Fiqh Islami*. Cairo : Darul Hadith.
- Mustofa, U. A. (2017). Syariah Card Perspektif Al-Maqasid Syariah. *Jurnal Ilmiah Ekonomi Islam*, 1(01).
- Nor Muhamad, N. H., Jaafar, M. A., Abdullah, M., Nizaludin, N. A., Salleh, M. M., & Mohd Zin, M. M. (2015). Konsep Maqasid Syariah Dalam Pengurusan Wakaf. *UMRAN - International Journal of Islamic and Civilizational Studies (EISSN: 2289-8204)*, 2(3).
- Ramli, M. A. (n.d.). *Objektif Syariah (Maqasid al-Syariah): Konsep Dan Kedudukannya Sebagai Teori Seismograf Hukum Islam*.
- Ramli, M. A., Islam, S., Zulkarnain, N. M., Farhan, M., & Ariffin, M. (2016). *Pemakaian Maqasid Al-Shariah (Objektif Syariah) Sebagai Seismograf Dalam Penilaian Isu Semasa*.
- Sa'id Azhar, H. (2010). *Maqasid As-Syari`ah `inda Imam al-Haramain Wa atharuha fi at-Tasarrufat al-Maliah*. Maktabah ar-Rushd Nashirun Riyadh.

THE CONCEPTUALIZE OF PRODUCT RANGE WITH SME OWNER PREFERENCE ON ISLAMIC SME FINANCING

Ahmad Aizuddin, H.^a Norhazlina, I.^b Amir Shaharuddin^c & Sumaiyah Abd Aziz^d

^aFaculty of Labuan International Finance, University Malaysia Sabah

^{b,c}Faculty of Economics and Muamalat, Universiti Sains Islam Malaysia (USIM).

Abstract

SME sector is the largest client in bank financing, especially in commercial business banking. An environment with a dual banking system, which is, both Islamic and conventional financial operate together, make the financial market more competitive. To ensure that Islamic financial products and services can compete with the existing market, Islamic banking management needs to ensure that its services have a place, especially to the SME sector. Among the steps that need to be taken is to know the banking product preference among those firms. Therefore, this study will formulate a conceptual framework for the factors of the product range of Islamic banking products to investigate Islamic SME financing preference among the SME owner. The product range of this range will be further strengthened with the theoretical support of planned behavior from the side of the Managerial perspective among the SME firms.

Keyword: SME financing, Islamic Banking, Source of capital, Halal business

1.0 INTRODUCTION

The life of a Muslim is not a freedom. Every horn of deeds is bound by the law of by sharia. This situation is to ensure that every Muslim always knows that they are only a servant to his creator. *Halal* and *Haram* are among the things that are very taken care of by them. *Halal* is an excerpt from Arabic which means things that permissible while this is the opposite of the word *Haram* which means things that need to be forbidden.

The rulings of *halal* and *haram* elements is very broad in the context of the daily life of Muslims. It is guarded through many angles. Among the aspects that are often highlighted are matters of worship such as prayer, fasting, and in terms of nutritional aspects such as food and beverage that contain alcohol as well as animals that are forbidden from Islam such as swine and so on. However, the awareness and knowledge of Muslims on *halal* and *haram* is unbalanced. Muslim community are more concern on the halal ingredient on the aspect of food. At the one part, in the area of trading and business transaction for example, the shariah requirements especially on the part of financial matters are still left behind. The halal business operator only ensures their production meet the requirement of the halal standard procedure but, not on their source of capital. For this reason, it make challenges for Islamic banking to growth and at the same time extend their financial market share in Malaysia.

Although the existence of the Islamic financial system in Malaysia reaches the age of 40, but the awareness in the importance of this system is still low, especially to SME business entrepreneurs. More than half of the country's small and medium enterprises (SMEs) are not fully aware of the availability of Islamic business facilities (Edge, 2019). Due to that, most of the entrepreneur adopts conventional banking practice instead of Islamic financing. The ultimate goal of banking customer is to get the financial resource. Issues in the formation of the product are less emphasized. This make most of the client in financial market treat the Islamic financial system as the same as conventional.

This matter is also one of the issues that is less emphasized in financial management for industry enterprises in Malaysia, especially for those who hold a Halal certificate. Halal ecosystems in the business chain in Malaysia are limited to the products and services provided. The financial resources owned by these firms are not made one of the processes in obtaining their Halal certification. This situation causes these two industries to develop without the support of each other. Thus, Ishak and Man (2011), argue that the government need to plan a new policy in Halal ecosystem which can strengthen the connection between both industries. Thus, it is important to ensure that 'halal' encompasses every aspect of the halal industry, including its financing, which must be fully free of interest-based debt financing (Abdullah & Oseni, 2017). If financial resources are taken from a Shariah non-compliant

based such as conventional bank, the goods and services supplied by those financial resources technically would assume is haram (IFN 2014).

Beside purification on production, a Halal assessment also evaluate the shariah compliant status of the firm. A firm with the title of Shariah compliant based are not assess the region based of the owner. It much more on the character of the firm itself. One component which are the criteria of shariah compliant status for a firm is the assessment of their component on the usage of their financial instrument. The financial resources element in the enterprise is also one of the important things in ensuring that the business belongs to a Halal status firm. A different approach is implemented by the securities commission (SC) of Malaysia in their shariah stocks screening process. Apart from the aspects of goods and services provided by the company, the determination of stock with halal status also touches on the aspect of their financial resources. Financial management involving banking services such as deposit saving and financing must comply with the guidelines provided by the SC. Labelling as a shariah-compliant stock to a company on Bursa Malaysia must ensure that services from conventional banking are limited to 33% of the overall service.

Although such policies are not used by the government in determining Halal certification to business premises, but it can provide guidance to industry players to know their business status. Indirectly, awareness in Islamic finance among SME entrepreneurs can be improved. At the same time, the government also continues to play its role in supporting the growth of Islamic finance when it is made one of the key players in supporting the policy of Halal Development Master Plan 2030.

The cooperation of all parties is necessary in strengthening this Islamic financial system, especially in Malaysia. Therefore, as a platform in the provision of Islamic financial services, institutional players need to formulate new strategies in strengthening the performance of their services. In 2018, Bank Negara Malaysia (BNM) has activated a new development strategy for Islamic financial institutions in Malaysia. A Value Based Intermediation (VBI) proposed by the central bank in order for the Islamic financial institution to enhance their marketability. In addition to the aspect of profit, the true value of Islamic teachings is emphasized in the framework of this strategy model. The concept of mutual assistance is given full support in ensuring that the Islamic financial system remains supported by the local community, especially business entrepreneurs.

To ensure the strategy and framework plan from the government in ensuring the growth of the Islamic financial system in Malaysia runs smoothly, views and support by banking customers are necessary. Therefore, this article will formulate a new framework in looking at the factors that drive Islamic SME finance preference among the SME owner in Malaysia. By applying the theory of Planned behavior, a new variable is proposed which is the product range factor. The continuation of this article will be followed by discussions in previous literature studies and further propose a new conceptual framework on Islamic SME financing preference among the SME owner.

2.0 LITERATURE REVIEW

2.1 Islamic Banking

The operation of the Islamic financial system is different from the existing financial system. There are three main pillars of business in Islamic financial institutions, namely, emphasizing the aspects of partnership, sale and purchase transactions as well as the rental system (Hamzah & Gazali, 2015). These contracts will be developed to create an interest-free banking product based on the provisions outlined by Shariah. Ahmad (1994) argues that Islamic banking within an Islamic economic system must be based on zero-based interest, equity participation, joint ventures and profit sharing.

All these contracts are used in existing banking products such as deposits and financing and also exist in investment banking services. Among the shariah business contracts used in Islamic banking products are, *Musyarakah* and *Mudarabah* (Partnership), *Ijarah* and *Ujr* (rental and wages) and sale and purchase contracts such as *Murabahah*, *Salam*, *Istisna* and *Bai Bithaman Ajil*.

Islamic banking is encouraged to use the principles of *mudarabah* and *musyarakah* in their transactions. Products like this receive many requests from banking customers because it can help ease their financial burden, especially in terms of business capital assistance (Haron & Ibrahim, 2016). The concept of profit and loss sharing (PLS) in this contract is seen as fair to both parties and avoids the issue of zero-win situation. Such a principle is also one of the differences that can be seen between the Islamic financial system and the existing banking. However, Islamic Banking nowadays is difficult to apply such a contract in their products and services. This is because Islamic banking will be at high risk due to the uncertain current situation. Besides, some studies (Siddiqi, 1985; Rosly and

Bakar, 2003) regard PLS as the only strict principle of an Islamic banking system. Therefore, Islamic banking operations are now more focused on sale and purchase and renting contracts in their banking products. as it also make the product of Islamic banking differ from conventional approach where shariah mode of contract are adopting on their entire banking operation (Amin, 2020).

2.2 Past Study on SME with Islamic Banking

There are several previous studies investigate the relationship between the Islamic banking system and the SME sector. This relationship is seen in two different approaches, namely bank lending relationship dan adoption of SME owner. A study from Aysan, et al. (2016) reveal that, Islamic banks (known as Participation banks in Turkey) are more inclined toward financing SMEs than conventional banks. Moreover, as all noticed that, SME character are opaque in nature but, the quality of SME for Islamic bank's is comparable to that of conventional banks. Meanwhile, Shaban, et al.(2016) argue that, in the model of price competitiveness, the Islamic finance control the market as the nature of its products. While, different result finding by Masduzzaman, et all (2018) which, effect of Islamic and conventional banking on SME firm efficiency is flow at the same way. Different type of financial resource does not affect the firm performance unless any other factor included such as size, of the firms, sector and business location.

On the aspect of behaviour approach, the adoption of SME owner towards Islamic banking reveal some different result. Shaharuddin, et all. (2005) investigate the perception of SME business on Islamic finance on their business financial instrument used. The factors determined such as knowledge, satisfaction, acceptance, and perception of the SME owner towards the reliability of the Islamic financial instrument. Based on that, the SME owner less prefer the Islamic finance as the most desirable financial institutions. Meanwhile, studies conducted by Jaffar & Musa, (2014) take different approaches. They argue that there is a link between industry players gaining Halal certification status with the Islamic financial sector. Therefore, further investigations were conducted using the Theory of Planned Behavior to look at the intentions of these SMEs on Islamic financial products. It is shows that, the factor of attitude, subjective norms and perceived behavioural control significant for the intention of SME owner on Islamic financial products.

Also, the rapid growth of the Islamic financial sector in Africa has led to further studies by (Badaj & Radi, 2018) to look at the perception of these SMEs on Islamic financial services. With the development of the theory by the previous researcher, this study uses the Decomposed Theory of Planned Behavior and evaluated eleven dimensions to examine the SME financing system's actions against the profit and loss method. The 11 variables are Cost, Risk Sharing, Business support, Loss of control, Access to conventional Debt, stage of development Financial suitability, religious beliefs, Normative beliefs, self-efficacy and facility condition. Each of these variables is reacting differently. There is a connection between these factors and some of them are opposed.

Considering the wide variety of results of previous studies on the use of Islamic finance instruments, further studies by Al Balushi, et al, (2019) look at other aspects of lending, especially among SMEs. Among the items used to view this relationship are SME manager knowledge, size, and firm characteristics. By using the Oman Muscat, as a research site, the results show that specific knowledge and attributes are related to the use of Islamic financing but not to firm characteristics. The entrepreneur's knowledge of Islamic finance with the familiar Islamic finance contract is closely linked to their decision to choose Islamic financial instruments. However, knowledge of the contract of ijarah has no relation whatsoever to the years of contracting *Musyarakah*, *Murabahah*, and *Mudarabah*. This implies that their understanding of experience depends only on contracts that they understand. In addition, the backbone of SME entrepreneurs reflects some different factors in influencing them to use these Islamic financial services. Gender differences and educational background are supportive of this relationship but not to differences in marital status and age of entrepreneurs. However, for the characteristics of the firm's characteristics, it is found that the relationship between the features of the prime and the use of Islamic finance instrument does not exist. Due to the limited size of the study area, this decision has yet to represent the entire SME community in general and needs to be applied further to developing countries.

2.3 Product Range

Products and services are one of the factors that motivate customers to buy and use the goods. different tastes and desires cause the customer to weigh before making any purchase decision. In business matters, owners will look into many things including the needs of their company. If a product and service supply a large chain of products, then their tendency to own such goods and services is high. This is acknowledged when the findings of a study from Abdul-Hamid et al (2011) and Amin (2008) found that product type is an incentive for customers to use Islamic home financing products. Amin (2008) also argues that, the question of shariah compliance causes Islamic home financing products to provide a wide range of products and according to the needs of consumers. Mean while,

in the context of price competition, the diversification of Islamic financing products especially to the SME sector causes Islamic banking to be in high demand compared to conventional banking (Shaban et al., 2016). Product range is an element that was not taken into account by previous researchers in looking at the relationship of Islamic financing adopting among the SME owner. Enterprises of SME firms that provide halal goods and services are polluted if their financial resources come from usury sources (Abdullah & Oseni, 2017).

3.0 CONCEPTUAL FRAMEWORK

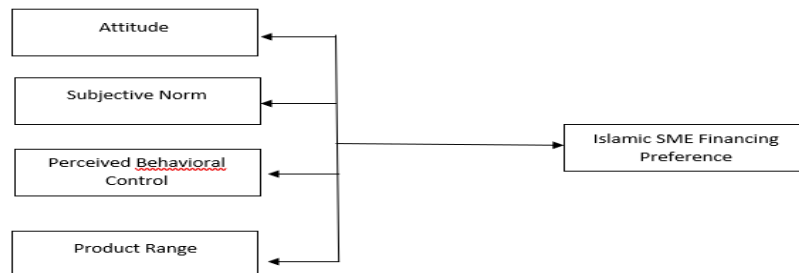

Figure: a conceptual framework of product range towards Islamic SME financing preference

4.0 CONCLUSION

Financing is a necessity for all. For the business sector, especially those SME firm categories, capital injection is vital for their business growth. As a financial services provider, Islamic banking needs to play an essential role in ensuring that every SME enterprise is not left behind in enjoying Sharia-compliant financial facilities. This also coincides with Islamic banking's primary goal, which is to prioritize social relations rather than profit. The importance of shariah-compliant financial resources is paramount, especially to entrepreneurs who supply halal products and services. This will make the flow of the halal ecosystem perfect by considering all the factors. Therefore, research in looking at the factors that motivate SME entrepreneurs to make decisions about their financing capital from resources that follow Shariah methodology should be updated to get a more robust relationship framework.

REFERENCE

- Abdullah, S., & Oseni, U. A. (2017). Towards a shari'ah compliant equity-based crowdfunding for the halal industry in Malaysia. *International Journal of Business and Society*, 18(S1), 223–240.
- Abdul-Hamid, M., Yaakob, N.I., Mujani, W.K., Sharizam, M. and Jusoff, K. (2011), "Factors adopting Islamic home financing: a case study among consumers of Islamic banks in Malaysia", *Middle-East Journal of Scientific Research*, Vol. 7, pp. 47-58.
- Ahmad, Z. (1994), "Islamic banking: state of the art", *Islamic Economic Studies*, Vol. 2 No. 1, pp. 1-34
- Al Balushi, Y., Locke, S., & Boulanouar, Z. (2019). Omani SME perceptions towards Islamic financing systems. *Qualitative Research in Financial Markets*, 11(4), 369–386. <https://doi.org/10.1108/QRFM-06-2018-0078>
- Amin, H. (2008). Choice criteria for Islamic home financing: Empirical investigation among Malaysian bank customers. *International Journal of Housing Markets and Analysis*, 1(3), 256–274. <https://doi.org/10.1108/17538270810895105>
- Amin, H. (2020). Critical success factors for the receptiveness of Islamic home financing in Malaysia. *International Journal of Emerging Markets*, 15(5), 849–873. <https://doi.org/10.1108/IJOEM-04-2018-0187>
- Aysan, A. F., Disli, M., Ng, A., & Ozturk, H. (2016). Is small the new big? Islamic banking for SMEs in Turkey. *Economic Modelling*, 54(October 2015), 187–194. <https://doi.org/10.1016/j.econmod.2015.12.031>
- Badaj, F., & Radi, B. (2018). Empirical investigation of SMEs' perceptions towards PLS financing in Morocco. *International Journal of Islamic and Middle Eastern Finance and Management*, 11(2), 250–273. <https://doi.org/10.1108/IMEFM-05-2017-0133>
- Edge, T. (2019). *BNM tells SMEs to look past misconception into Islamic financing facilities*. 1–8.
- Hamzah, A. A., & Gazali, H. M. (2015). The roles of Islamic financing towards the successful of Islamic micro enterprise: A study in labuan. *International Journal of Business, Economics and Law*, 8(1), 8–11.
- Haron, R., & Ibrahim, K. (2016). Islamic financing in mitigating access to financing problems of SMEs in Malaysia: A survey analysis. *Intellectual Discourse*, 24, 387–408.
- Jaffar, M. A., & Musa, R. (2014). Determinants of Attitude towards Islamic Financing among Halal-certified Micro and SMEs: A Preliminary Investigation. *Procedia - Social and Behavioral Sciences*, 130, 135–144. <https://doi.org/10.1016/j.sbspro.2014.04.017>
- Masduzzaman, M., Akther, M., & Ara, S. (2018). Efficiency of SMEs financed under conventional and Islamic banks: Bangladesh perspective. *Journal of Islamic Economics, Banking and Finance*, 14(1), 61–70. <https://doi.org/10.12816/0051167>
- Rosly, S.A. and Bakar, M.A.A. (2003a), "Performance of Islamic and mainstream banks in Malaysia", *International Journal of Social Economics*, Vol. 30 No. 12, pp. 1249-6
- Shaban, M., Duygun, M., & Fry, J. (2016). SME's lending and Islamic finance. Is it a "win-win" situation? *Economic Modelling*, 55, 1–5. <https://doi.org/10.1016/j.econmod.2016.01.029>
- Shahrauddain, Amir, Suhaila Abdul Hamid., Yasmin Hanai M. Safian & Muhamad Muda. 2005. "A Study on Small and Medium Sized Enterprises Perception towards Islamic Banking Products". *Journal of Muamalat and Islamic Finance Research*. Vol. 2. No. 1. pp. 1-26
- Siddiqi, M.N. (1985), *Partnership and Profit-Sharing in Islamic Law*, The Islamic Foundation Leicester, Leicestershire.

SURVIVAL STRATEGIES ON MUSLIM SMALL AND MEDIUM ENTERPRISE (SME) OWNERS DURING COVID-19: A STUDY ON TOURISM INDUSTRY IN MALACCA.

Nuurul 'Afiah Mamad

International Islam University Malaysia

ABSTRACT

The issue of pandemic COVID-19 affected Malacca SMEs businesses in tourism industry to survive. The purpose of this qualitative study is to explore the problems faced by Malacca Muslim SME businesses in tourism sector and to identify survival strategies based on owners' perspective to sustain their business. This study used a descriptive analysis method of primary and secondary data obtained directly both from personal interview of business owners and from various documentation sources. The result found that the SME Muslim business owners problems during the pandemic COVID-19 measures are operation closed, cash flow problems and incentive rejected. Meanwhile, the main themes of current survival strategies relate to cost reduction, government incentives and problem-solving skills. Finding had implication to others SMEs business in the tourism industry to sustain their business by providing knowledge about the survival strategies required for small business.

Keywords

COVID-19, Survival Strategies, Small Medium Enterprises (SME), Tourism Industry, Malacca tourism

1.0 INTRODUCTION

COVID-19 is an infectious disease caused by a newly discovered strain of coronavirus, a type of virus known to be causing respiratory infections in humans. The COVID19 outbreak started explosively in Wuhan and spread throughout China (WHO, 2020). This virus spreads from the person to person and has been announced by the World Health Organization as a fatal global pandemic (BBC, 2020).

The COVID-19 epidemic in Malaysia started with a small wave of 22 cases in January 2020 through imported cases. It was accompanied by a larger wave mainly from local transmissions resulting in 651 cases urged Malaysia government to choose a more stringent measure (Ministry of Health Malaysia, 2020). A limited lock-down strategy called Movement Control Order (MCO) was immediately initiated to the whole country as a way to suppress the epidemic trajectory (*Mailis Keselamatan Negara*, 2020). The COVID-19 pandemic that led to movement control order (MCO) in the country added pains and difficulties to the economic situation, particularly the SMEs. During the MCO, all nonessential businesses were closed and affected SMEs in the tourism sector (Linda Bethke, 2020). The tourism sector, which employs 3.5 million people and contributes 15 percent to the country GDP, had seen revenues falling by 90 percent in March, adding that it was looking at a near-total loss in business for the months of April through June (The Star, 2020).

Tourism is considered one of the hardest hits by the COVID-19 outbreak. The sector is experiencing a rapid and sharp drop in demand and a rise in job losses worldwide, putting many SMEs at risk (Paola Maniga, 2020). SMEs are important in Malaysian economic and as the backbone in Malaysia tourism industry that third largest contributor to Malaysian GDP with RM 41.96 billion in the first half 2019 (Tourism Malaysia, 2019). SMEs in tourism industry had indicated a potential reduction in employment from anywhere between 70 percent and 90 percent over the coming few months in order to simply survive and also taking up any additional loans for fear of being saddled with further debt as recovery was expected to take much longer than expected (The Star, 2020).

Tourism is one of the Malacca major contributor to the economy and has many industry players from various sub-sectors (Malay Mail, 2020). Meanwhile, Melaka's tourism industry holds tremendous potential for the state because Malacca is well known for its well-preserved heritage and culture. On 7 July 2008 Melaka was formally identified as a World Heritage Site (WHS) by the United Nations Educational, Scientific and Cultural Organization (UNESCO) (Teo et al., 2014). The issue of pandemic COVID-19 affected Malacca SMEs businesses in tourism industry to survive.

Because of these issues, the purpose of this qualitative study is to explore the problems faced by Malacca SME Muslim businesses owners in tourism sector and to identify survival strategies based on owners' perspective to sustain their business. Qualitative study is involving a non-numerical data research that used to interpret meaning that help to understand social life through the study of phenomenon, targeted populations or places. According to Creswell (2014) qualitative study can be described as an approach to explore and understand the meaning of individuals or group attribute to a social or human problem. Qualitative study takes into account the natural contexts in which individuals or groups function, as its aim is to provide a comprehensive understanding of real-world problems (Korstjens & Moser, 2017).

2.0 RESEARCH OBJECTIVES

Based on the research topic, this research wants to identify the problems of the Muslim SME owners and their survival strategies. The research objectives as follows:

To identify the problems faced by the SME during pandemic COVID 19.

To explore the SME survival strategies to sustain the business during pandemic COVID 19

This paper includes two qualitative research questions related to research objectives which are:

What are the problems faced by the SME during pandemic COVID-19?

How SME businesses survive during pandemic COVID-19?

My research questions divided into two types philosophies which is ontology research question and epistemology research questions. For an ontology research question, my study is to find the nature of participant realities, then for the epistemology research questions my study is to knowing and understanding of the phenomenon of interest. In discussing ontology, Antwi & Hamza (2015) described ontology as the way the investigator defines the truth and reality. For the ontology question Guba and Lincoln (1994) stated that it is "what is the form and nature of reality?", "what is there that can be known about it?" Only those questions that relate to matters of real existence and real action are allowable. My ontology research question is "What are the problems faced by the SME during pandemic COVID-19?". This question is about to find the reality about the impact of pandemic COVID-19 to their business.

Epistemology refers to the branch of philosophy that studies the nature of knowledge and the valid kinds of knowledge (Grey, 2014). Epistemology question is a process that the investigator comes to realize the truth and reality or how do we know what we know? (Guba, 1990, as cited in Antwi & Hamza, 2015). Guba and Lincoln (1994) stated that epistemology question discover the objective of how the things really are and the things really work. For the second research questions in my study is "How to survive the SME business during pandemic COVID-19?". I was interviewed the business owner in tourism industry about what are the survival strategies that their applied to sustain their business during pandemic COVID-19.

3.0 LITERATURE REVIEW

The most seriously affected by the pandemic and the resulting Movement Control Order (MCO) are the small and medium sized enterprises (SME), which are now beginning to develop survival strategies to maintain their company. (Reeves & Deimler, 2009). SMEs are important drivers of economic growth by generating jobs, contributing to GDP, technological innovations and other aspects of economic and social development. The recession will intensify the decline of failed business models, accelerating the restructuring of entire industries (Reeves & Deimler, 2009). To survive the business, Porter (1980) recommends the following strategies, which have been called "Porter's Generic Strategies": cost leadership, differentiation of product or service, and emphasis on narrow segment.

The study on survival strategies used by commercial banks in Zimbabwe post dollarization (2009-2015) revealed that strategies used by commercial banks approaches product differentiation, superior distribution channels, effective risk management as well as technological innovation. The study also revealed that the major internal business factors that influence strategy implementation include resource availability, organizational structure, effective communication and good leadership.

In addition, among small and medium-sized enterprises (SMEs) in the Lagos State area of Oshodi-Isolo indicated the type of strategies adopted was indicted through integrative strategy, diversification strategy, differentiation strategy, generic competitive strategy, and corporate strategy, which resulted their sustainability within given period (Ifekwem & Adedamola, 2016).

Studying the survival strategy variables (SSVs) used by Malaysian construction firm in the past two economic downturns shows that the construction firms reacted differently in the two periods of recessions, and among the top five SSVs identified were management style, market penetration, quality improvement, business growth, and product creation (Abu Bakar et al., 2011).

Another study by Majukwa et al., (2020) on the strategies employed by the owners of small- and medium- sized enterprises (SMEs) in Zimbabwe use to sustain their companies by the passion and dedication, quality of goods and services, customer satisfaction and employing staff with the right skills.

Recent study by Ahmad Rafli, et. Al (2020) founded that the impacts of MCO on SMEs are classified into two problems. First, operational problems which are disruption of operation; disruption of supply chain; and fore sighting the future business direction. Second, the financial problems (i.e. cash flow imbalance; access to stimulus packages; risk of bankruptcy). While, the major themes of the current strategies for survival come under the financial and marketing strategies.

Hadi, (2020) recommends some policy and strategic guidelines to recovery SMEs in tourism industry with: (1) government funding for channel growth, and program coordination from various government departments would result in coordinated policies including the growth of export and domestic market advertising with a range of more current and diverse media. (2) Credit policies by banks with lower interest rates and simpler processes will thus help the acceleration of the revitalization process; (3) Improvement of the quality of physical and non-physical infrastructure, resulting in a higher competitiveness of the SME innovative tourism center in Yogyakarta City. Malaysia government provided many financial and non-financial incentives for SMEs businesses to sustain their business. Financial incentives include grants, loans, venture capital funding, or tax benefits, physical infrastructure, information and training (Lauren, 2020). According to Rohaya et. Al (2016) in the study about the effectiveness of the financial incentives provided by the government found that tax incentives have a positive impact on SMEs' performance. *Penjana Economic Recovery Plan* announced two incentives plans to every businesses sector in the tourism industry, such as travel agencies, hotels and airlines, will be given an extension period for deferment of tax instalments which is from Oct 1 to Dec 31, 2020.

Based on survival strategies that found and recommended by the researchers from all industry are different in terms of types of businesses, and factors. It shows that, SMEs have many strategies to sustain their business.

4.0 METHODOLOGY

Based on my research objective, question and paradigm, I choose multiple case study design to describe in depth experience of six owner of SME in tourism product. Mariotto, Zanni, and DeMoraes (2014) defined a case study as a detailed explanation of a business situation. Meanwhile, multiple case studies increase the possibility of direct replication which makes the conclusions resulting from independent cases more powerful than those from a single case (Yin, 2014).

The sample I was selected on five Muslim owners of SMEs business in tourism sector at Malacca (Table 1). The selection of interviewees based on characteristics of tourism product guidelines introduced by international organisations such as the United Nations World Tourism Organization (UNWTO), Eurostat, and the Organization of Economic Co-Operation and Development (OECD) are accommodation, travel & tours, food and beverage, and miscellaneous (Kalsitinoor Set, 2013).

Table 1 : Respondents

Respondent	Code	Gender	Type of Business	Methodology	Interview Date / Time
A	PI-1	Male	Food & Beverage	Face to Face Interview	13 June 2020 / 8.00pm-9.00pm
B	PI-2	Male	Food & Beverage	Phone Interview	14 June 2020 / 3.00 pm- 3.25 pm
C	PI 3	Female	Accommodation	Phone Interview	19 June 2020 / 6.00 pm – 6.30 pm
D	PI-4	Female	Miscellaneous	Phone Interview	19 June 2020 / 12.50 pm – 1.20 pm
E	PI-5	Female	Travel & tours	Phone Interview	2 July 2020 / 11. 10 am – 11.30 am

I was used personal interview and documents analysis method to collect data. Interview is a process in which a researcher and participant engage in a conversation focused on questions related to a research study (De Marias,

2004 cited on Merriam, 2009). The rationale for using the interview methods is to enable the researcher to find out what is on their mind, what they think and how they feel about something (Frankel J.R, 2000).

4.1 Procedure of Interview Process

Before the interview session I was contacted interviewees a few days early to ensure they get enough time to permission and well-prepared to answer the questions. First, I was introduced myself and telling them why this research is important to understand pandemic impact for SME. Second, after get their willingness to become a respondent, I was prepared consent letter and voluntary form then share it to them via WhatsApp or email. Third, I was make an appointment to set time and date.

I was used semi-structured interview in collecting data. According to Merriam (2009) semi-structured interview is a type of interview in the middle between structured and unstructured and the questions are more flexibly worded or the interview is a mix of more and less structured questions. The interview is guided by a list of questions or issues to be explored, and neither the exact wording nor the order of the questions is determined ahead of time. A set of questions are prepared as shown in Table 2. The questions are carefully designed to obtain appropriate evidence to support the research objectives.

Table 2: Interview Questions

Information	Questions	
Owner and business background	1	Can you introduce about yourself and business.
Problems and Survival Strategies	1	How does your business affected due to pandemic COVID-19?
	2	Can you elaborate how much your business had affected with pandemic COVID-19 in terms of cash flow and profit?
	3	How did you facing and overcome this issue?
	4	How do you manage your employees during pandemic COVID-19?
	5	What kind of strategies did you use to keep your business survive?
	6	What are you planning for the future that help your company survive during and perhaps after the MCO and CMCO?
	7	Did you get information about initiatives by the government to help SME sector?
	8	Do you get help from government to sustain your business?.
	9	How far initiatives by government help to sustain your business?
	10	What kind of help that you need by government to improve SME business?

This interview was conducted by face to face and audio telephone call based on interviewees consent because of Conditional Movement Control Order (CMCO) still running. I will tell them that the interview will be fully recorded and get their permission first. Beside that I also take note all the information by writing it at my notebook. I conducted the personal interviews in a quiet public area near the participant place of business and for phone interview by telephone call at home. Interviewees need to answer each question in two minutes include the time of I read the questions. Total time of this interview will be held in 20 – 30 minutes.

For the document's analysis, I collected data about the problems and survival strategies among the SME through press release (online newspaper) and survey data. The press release and survey data enabled me to determine the issue and survival strategies to sustain the business during pandemic COVID-19.

Reflections on the Interview Process

For all the interview session, throughout this process, I learnt that as researchers also need to act as participant in order to ask the questions covered in my research. Besides, I need to pay attention to detail, record and take note for all of the information during the interview process.

Validity and Reliability

Furthermore, I learned that validation and reliability are also critical to maintaining the trust (Lincon & Guba, 1985). Validation is how accurately the data represents the participant's view of a phenomenon (Marshall & Rossman, 2016). I have already prepared and distributed consent letter and voluntary form to the selected respondents for process validation, as annexed in the appendix. I have used the instrument for collecting data for this research study. I used an audio recorder and written in paper to capture the participant's answers. I used data triangulation to validate the information accurately with document analysis. In data triangulation, the same data

from different sources is collected with the hope that the information will converge to validate the data (Denzin, 1970).

For reliability process, I gathered my data by strictly adhering to my interview protocol. I used the interview protocol to guide the interview process. I had a list of basic questions like those about background and introduction about their business. I then moved to the more difficult questions about the impact of pandemic COVID-19 and survival strategies. The interview protocol kept me focused on the questions that provided me with the data.

Data is trustworthy because it has established dependability if the finding can be repeated by another researcher using similar participants in similar conditions (Koch, 2006). I personally transcribed the audio recordings and information of the interviews in Bahasa Malaysia. For the next process my friends translated the transcribed verbatims in English language and then another friend translated it again into Bahasa Malaysia. I also gave the respondents the opportunity to check the transcripts and give feedback about their accuracy. All the respondents confirmed that my interpretations represented exactly of what they had shared during the interviews.

5.0 DATA ANALYSIS

For data analysis, I used Microsoft word and Microsoft excel to transform the collected data into codable units for analysis. The process of this research based on three (3) phases of coding: open coding, axial coding and selective coding. In the open coding, for the labelling events, it consisted of placing conceptual labels on discrete happenings, event and instances in data.

The researcher combined the data for axial coding, and for selective coding it involved identifying and selecting the core categories, and these core categories were systematically linked to related core categories. Additionally, the actual names of respondents were not visible during this process, but they were given a unique code / ID to protect their identity. After I translated all the data into codes, the data analysis process began.

6.0 RESULTS

6.1 The problems faced by the SME during pandemic COVID 19

The main problem of pandemic COVID-19 to the Muslim SME owners in tourism sector is operation closed. All of the respondents highlight their main concerns on the operation closed during the MCO [PI-1, PI-2, PI-3, PI-4, PI-5] as shown in Table 3. The government order on the closure of all non-essentials business premises had stopped the SMEs business in the tourism sector which is accommodation, travel & tours, food and beverage, and miscellaneous. The media previously reported that three hotels in the Malacca had announced they were shutting operations following the Covid-19 outbreak (DI-1).

These necessarily led to cash flow problems as reported by Department of Statistics Malaysia (2020) where 67.8 percent of respondents of the companies/ business firms participating in the Special Survey Effects of Covid-19 (Round 1) stated that no sales/revenue during MCO. Some business recorded "no income" after the total business lockdown during the MCO (PI-1, PI-3, PI-4, PI-5) and some business dropped around 70 % compared to the previously (PI-2). More than 50% out of 419 companies (respondents) revealed that revenue had dropped by more than 50% (DI-2). Although the business have the issue with cash flow, the Muslim owners are still obligated to make compulsory expenses such as the staffs' salary, business loans, rental fees, utilities and other fixed costs. Some Muslim business owners had faced the problem with the business stimulus package (PRIHATIN Economic Stimulus Package 2020 and Additional PRIHATIN SME Economic Stimulus Package or PRIHATIN SME+) because all the application was rejected (PI-3).

Table 3: The problems faced by the SME during pandemic COVID 19

Theme	Interview Transcrip
Closed Operation	<p>"Not affected much to myself, because I have another business. But for restaurant business, yes affected. We couldn't run business" (PI -1).</p> <p>"My business affected very much because I had to closed my business during MCO (PI-2)"</p> <p>"Very affected. We were closed our hotel because there are no customers for three months" (PI-3).</p>

	<p>“Very affected in terms of income because we need to shut down our SPA” (PI-4).</p> <p>“Worse, no business running during MCO and we have to shut down our office” (PI-5).</p> <p>“The media previously reported that three hotels in the state had announced they were shutting operations following the Covid-19 outbreak” (DI-1).</p>
Cash Flow Problems	<p>“Within 3 months closed the business, and no income. I Loss around RM 500,000.00 a month “ (PI-1)</p> <p>“No income and the losses is around RM 50,000.00 a month” (PI-3)</p> <p>“My business income was affected because 3 month we need to closed the SPA business” (PI-4).</p> <p>“No income at all” (PI-5)</p>
	<p>“My business dropped around 70 % compared to the 58organizati “ (PI-2).</p> <p>More than 50% out of 419 companies (respondents) revealed that revenue had dropped by more than 50% (DI-2).</p>
Application Rejected	<p>Unfortunately, my applications were rejected. I don't apply wage subsidy because I don't have employees and I don't pay the PERKESO. Now, I try to apply zero rate loan from <i>Bank Simpanan Nasional</i> and hope the application will approve (PI-3)</p>

6.2 THE SME SURVIVAL STRATEGIES TO SUSTAIN THE BUSINESS DURING PANDEMIC COVID 19

6.2.1 Cost Reduction

Cost reduction is the first step and smart tactic for many companies to survive the business (Roger Perry, 2020). Most of the employers choose this strategy to survive their business during pandemic COVID-19. Employers are beginning to cut salaries as the economic impact of the corona virus pandemic begins to bite their bottomline (D-2). The small and medium enterprises (SMEs), who are now beginning to look into salary cuts to survive (D-2). Reduction on work days per week (39%), reduction in some benefits agreed in the collective agreement for unionised companies (34%) and reduction in working hours per day (29%) (D-2). Based on the interview to the owner of business, the cost reduction that their applied with grant leave to their employee without payment (PI-5) paid basic salary (PI-4), revised the salary (PI-2) and paid half of salary (PI-1).

6.2.2 Government Incentive

Government incentive are important in encouraging and supporting SMEs business (Henry, 2010). Malaysian government announced business stimulus package (PRIHATIN Economic Stimulus Package 2020 and Additional PRIHATIN SME Economic Stimulus Package) to help the SMEs sustain their business. All five respondents were applied the incentive offered by the government, but only four respondents approved for wage subsidies by PERKESO.

6.2.3 Wage subsidies

The government has provided businesses with a RM10 billion assistance plan targeted at small and medium-sized companies to subsidize certain salaries for a three-month period (D-2). Wage subsidies as “income to employees besides of EPF withdrawal to less the burden” (P5). “Alhamdulillah, that incentives could relieve my burden to cover my staff's salary cost” (PI-2, PI-4). “Government incentive actually helping our SMEs entrepreneurs very much. I also applied this incentive to help less burden for my workers because during MCO, they have no job and get half of salary” (PI-1).

6.2.4 Tax exemption

Tax incentives have a positive impact on the success of SMEs in maintaining their company during the recession (Rohaya et. Al, 2016). Full tax exemption also will be given to the tourism industry players in the beginning this July to June 30 2021 to help those affected by the current situation and as part of efforts to revive the country's tourism industry (D-1).

This result reinforced evidence at Rohava et. Al (2016) in the study about the effectiveness of the financial incentives provided by the government found that tax incentives have a positive impact on SMEs' performance.

6.2.5 Problem Solving-Skill

Problem solving skill important to employer to overcome obstacles and find a solution that best resolves the issue to survive the business (Abu Bakar et al., 2011) . From the interview of respondents found they looking for another income by online business "I did online business by Facebook. I am selling shampoo hair care product manufactured by my SPA. The income from online business can help me to pay employee's salary" (PI-4). Other respondents change the operation system from dine in at restaurant to take away "After the MCO, I was running my business for take away to cover business income" (PI-2).

The respondents also will improve their marketing strategy to survive the business. "I will improve marketing strategy and use media social for attract tourist and local people to come to my shop" (PI-2). We need to restart again our domestic package by promoting through social media (PI-5).

7.0 CONCLUSION AND DISCUSSION

The purpose of this qualitative study is to explore the implication of the Covid-19 on Malacca SME Muslim businesses owners in tourism sector and to identify survival strategies based on owners' perspective to sustain their business in line with the resource-based perspective. To summarise, the problems faced by the Muslim owners of SMEs during the COVID-19 pandemic are operation closed, cash flow problems and incentive rejected. There is consensus among respondents that the main themes of current survival strategies relate to cost reduction, government incentives and problem-solving skills. The accumulated financial resources of the organization are very efficient instruments for stabilization during the crisis era, while other assets and skills enable companies to respond to new market opportunities.

7.1 Implications.

From a practical perspective, the findings of this study are useful and highlight the contribution such as bellow:

7.1.1 Contribution to the Researcher/s

Based on this study, the researcher received a new knowledge and good experience, which can help to solve some existent problems. Other than that, the researcher will be expose to the real working environment and face some problems that exist in the organization and these problems can be good information for better preparation in problemsolving skills. For other researcher/s, it will benefit in term of limitations in this research that suggest for another area to conduct of study.

7.1.2 Contribution to the SMEs Business

The results of this study may help others SMEs business in the tourism industry to sustain their business by providing knowledge about the survival strategies required for small business. Applying the knowledge gained from this study may enable small business owners to direct their limited business resources to those areas critical to the survival of the business. The findings from this study might contribute to positive social change by reducing the burden on business owner. The respondents, as small business owners, used their determination and managed the uncertain situation to support their small businesses by getting prepared with good financial planning and emergency funds to cover payroll and other fixed costs for at least six months. SMEs must have some degree of strategic capabilities and be agile enough to adapt in times of crisis as modern companies are exposed to numerous unexpected global crises. Investment in technology, software, online marketing and new distribution network are important in unpredictable future of the Covid-19 pandemic crisis

REFERENCES

- Abu Bakar, A. H., Yusof, M. N., Awang, A., & Adamy, A. (2011). Survival Strategies Of Construction Companies In Malaysia Duri ng Two Periods of Recession. *International Journal of Academic Research*, 3(4), 481–486.
- BBC. (2020). Coronavirus: What is a pandemic and why use the term now? Retrieve from <https://www.bbc.com/news/health-51358459>
- Creswell, J. W. (2008). *Educational research: Planning, conducting, and evaluating quantitative and qualitative research* (3rd ed.). Upper Saddle River, NJ: Pearson Education.
- Distribution of COVID 19 cases. Available at <http://covid-19.moh.gov.my/> (Accessed on 20 April 2020)
- Frankel J.R. (2000). *How to Design and Evaluate Research in Education*. USA: Macgraw-Hill.
- G. Ramesh Babu. (2008). *Research Methodology in Social Sciences*. India: Concept Publishing Company
- Hadi, S. (2020). Revitalization Strategy for Small and Medium Enterprises after Corona Virus Disease Pandemic (Covid-19) in Yogyakarta. *Journal of Xi'an University of Architecture & Technology*, XII(IV), 4068–4076. <https://doi.org/10.37896/jxat12.04/1149>
- Henry, C. (2010). Guest editorial. *Environment and Planning C: Government and Policy*, 28(2), 191–194. <https://doi.org/10.1068/c2802ed>
- Ifekwem, N., & Adedamola, O. (2016). Survival Strategies and Sustainability of Small and Medium Enterprises in the Oshodi -Isolo Local Government Area of Lagos State. *Acta Universitatis Sapientiae, Economics and Business*, 4(1), 103–118. <https://doi.org/10.1515/auseb-2016-0006>
- Kalsitinoor Set. (2013). Tourism Small and Medium Enterprises (TSMEs) in Malaysia. *International Journal of Business and Social Science* Vol. 4 No. 16
- Lincoln, YS. & Guba, EG. (1985). *Naturalistic Inquiry*. Newbury Park, CA: Sage Publications.
- Majukwa, D., Fan, S. K., & Dwyer, R. J. (2020). Impact of sustainability strategies on small- and medium-sized enterprises in Zimbabwe. *World Journal of Entrepreneurship, Management and Sustainable Development*, 16(2), 149–163. <https://doi.org/10.1108/WJEMSD-10-2019-0079>
- Marshall, C., & Rossman, G. B. (2016). *Designing qualitative research* (6th ed.). Thousand Oaks, CA: Sage Publications, Inc.
- MEDIA STATEMENT - Findings of Special Survey (Online) Effects of COVID-19 on Economy and Companies/ Business Firms. (2020, July 20). Retrieved from https://www.dosm.gov.my/v1/index.php?r=column/cfour&menu_id=b1d2TmwvM3VUcHRVYk53cFVycm1wZz09&bul_id=akRBOTBxeW1NOUZ6N0ZEdU1zbFJ6dz09
- Norman K. Denzin & Yvonna S. Lincoln. (2011). *Handbook of Qualitative Research*. Thousand Oaks, United States : SAGE Publication Inc
- Perintah Kawalan Pergerakan (Movement Control Order). (2020, April 22). Retrieve fro <https://www.mkn.gov.my/web/ms/covid-19/>
- Reeves, M., & Deimler, M. S. (2009). Strategies for winning in the current and post-recession environment. *Strategy and Leadership*. <https://doi.org/10.1108/10878570911001444>
- Roger Perry. (2020 March 26). COVID-19: A Survival Strategy for Extreme Economic Turbulence Retrieved from <https://www.victorianchamber.com.au/news-media/all/2020/03/covid19-a-survival-strategy-for-extreme-economic-turbulence>
- Rohaya, Md Noor & Shuid, Siti & Marlia, Siti & Hussin, Siti. (2016). SMEs' Performance Financial Incentives and Governance. 10.1007/978-981-10-0036-2_11.
- Sharan B. Merriam. (2009). *Qualitative Research A Guide to Design and Implementation*. United States of America: Jossey Buss Tourism contributes RM41.69 billion to Malaysia economy with 13.35 million tourists in the first half of 2019 . (2019, august 23). 60 rganizat from <https://www.tourism.gov.my/media/view/tourism-contributes-rm41-69-billion-to-malaysia-economy-with-13-35-million-tourists-in-the-first-half-of-2019>
- Teo, C. B. C., Khan, N. R. M., & Rahim, F. H. A. (2014). Understanding Cultural Heritage Visitor Behavior: The Case of Melaka as World Heritage City. *Procedia – Social and Behavioral Sciences*, 130, 1–10. <https://doi.org/10.1016/j.sbspro.2014.04.001>
- World Health Organization. (2020, May 11). Coronavirus Disease 2019 (COVID-19): situation report, Retrieved from <https://www.who.int/docs/default-source/coronaviruse/situation->

EMBRACING ISLAMIC CONCEPT OF CORPORATE GOVERNANCE OF WHISTLE-BLOWING IN MALAYSIA

Wong Hua Siong

School of Law, College of Law, Government and International Studies, Universiti Utara Malaysia, Malaysia

Abstract

Whistle-blowing in the corporate world has emerged to be one of the vital issues of company laws and corporate governance. It is an important element in the enforcement of the company laws. In our continuous effort to promote good corporate governance, visible and timely enforcement of the laws are critical. The act of whistle-blowing can cause a conflict of interest between individual, organizational and society per se. Much of the disagreement arises from the view that a whistle-blower is a person who possessed the knowledge of mismanagement by others or a person who is disloyal to the organization that employed him or her. A whistle-blower is a person who informs the stakeholders about a person who engages in an unlawful or immoral activity. It is difficult for the whistle-blower to reveal incidents of abuse, mismanagement or corruption that occurred in the workplace. Thus, this paper will examine the issues and challenges whistle-blowers face and the available whistle-blower laws that can protect their rights and well-being. The common law protection of whistle-blowers from other common law jurisdictions is examined and the prospective the application of the Islamic concept of good corporate governance is suggested to be more efficacious. This is qualitative study that involves a systematic study of philosophical and academic views through literatures. Therefore, this study is not an empirical study but rather a library study from various primary data sources such as Quran, Hadis, relevant cases and legislations and secondary data sources namely articles and journals from online database. The study found that many countries have started to pay attention to the importance of whistle-blowing by enacting the relevant legislations to protect whistle-blowers and at the same time to promote good governance within both the public and private organizations. Whistle-blowers in Malaysia are protected by the Whistle-blower Protection Act 2010 ('WPA 2010') has shown its commitment in eliminating corporate fraud, corruption and misbehaviour through the enactment of the WPA 2010. It is submitted that there is still a bridging gap between whistle-blower protection and good corporate governance practices in Malaysia compared to common law and civil law countries.

Keywords: Whistle-blowing, whistle-blower, corporate governance, Islamic concept

1.0 INTRODUCTION

Whistle-blowing in the corporate world has emerged to be one of the emerging issues of company laws and corporate governance. It is an important element in the enforcement of the company laws. In our continuous effort to promote good corporate governance, visible and timely enforcement of the laws are critical. Good corporate governance should not limit itself to one's own company, but also should consider the ramifications on the public interests. The Oxford dictionary defines whistle-blower as "a person who informs on a person or organization regarded as engaging in an unlawful or immoral activity". On the same premise, Gregory R. Watchman⁵ stated that "Whistle-blowers are citizen activists who are witnesses to wrongdoing and seek to correct it. They play a vital role in an open, democratic, society by holding our institutions accountable to the people they serve." While Pascoe and Rachagan stated that "Whistle-blowing is a term used to describe the disclosure of information by someone who reasonably believes such information is evidence of contravention of any laws or indicates mismanagement, corruption or abuse of authority."⁶

Thus, a whistle-blower can be a person who is an employee of a company, a government department, a contractor, or a supplier who becomes aware of any illegal activities and divulged the information to the general public or the

⁵ Gregory R. Watchman, Executive Director of the United States' Government Accountability Project ("GAP") (a non-profit public law firm founded in 1977 to advance corporate and governmental accountability, primarily through whistle-blowing advocacy work) "Sarbanes-Oxley Whistle-blowers: A New Corporate Warning System", GAP's Website, Nov. 2004. <<http://www.whistle-blower.org/doc/GAP%20Analysis%20Sarbanes%20Oxley%20Epd>>. Accessed on 1 Mac 2018.

⁶ Pascoe, Jannie and Shanthi Rachagan, "Key Development in Corporate Law Reform in Malaysia", Singapore Journal of Legal Studies [2005] 93-113.

enforcement agency on any wrongdoing, i.e., fraud, corruption, etc. A whistle-blower usually conveys and shares the knowledge on any wrongdoing which he/she thinks occurs in the whole organization or only in a specific department. To protect whistle-blowers from being victimized, such as dismissal from a job or being mistreated, there are specific laws safeguarding the whistle-blowers. In addition, most companies have a separate policy informing their employees how to report such an incident.

A whistle-blower can also file a lawsuit or a complaint with the enforcement agency which will conduct a criminal investigation against the company or any individual department. There are two types of whistle-blowers, i.e., internal and external. Internal whistle-blowers is those who report the misconduct, fraud, or indiscipline to senior officers of the organization, e.g., Head of Human Resource or CEO. While, the external whistle-blowing refers to a situation where a whistleblower reports the wrongdoings to people outside the organization, i.e., the media, enforcement agency, or police. The crime or wrongdoing could be in the form of fraud, deceiving employees, corruptions, or any other act which misleads the stakeholders.

It must be emphasized that over the years, the role played by the whistle-blowers has gained popularity and recognition in the corporate world. Although there is a certain degree of loyalty towards the employers, an employee's duty to the public at large is said to be more important as collapse of a giant corporation would have a negative impact to many stakeholders. The whistle-blowers risk their jobs and often facing retaliation for their action as they are treated as the 'traitors' of the company, even though their action was for the benefit of the public at large including the company itself.

Generally, whistle-blowing is an activity or action when a person who is generally known as whistle-blowers who reveals any kind of information or activity that is deemed or to be deemed illegal, unethical, or incorrect in their organization, either private or public organization. It should be noted that the disclosure or reporting could be made internally, to the management of the company or externally, to any third party. Vigilance is the key in resolving or deterring any malpractice or wrongdoing in any company.

This paper examines the issues on the challenges, laws, rights and well-being of whistle-blowers and aspects of good corporate governance. It will also analyse the legal positions of whistle-blowers in other jurisdictions, particularly, Australia, United Kingdom, United States, New Zealand and Malaysia; The paper also proposed the application of the Islamic concept of whistle-blowing and good corporate governance to further make them more efficacious.

2.0 RESEARCH METHODOLOGY

This is qualitative study that involves a systematic study of philosophical and academic views through literatures. Therefore, this study is not an empirical study but rather a library study from various primary data sources such as Quran, Hadis, decided cases and secondary data sources namely articles and journals from online database. In order to address the research objectives and research questions, the involved extensive literature review of the laws relating to whistle-blowing and corporate governance from the newspaper reports, reported cases, scholarly articles, textbooks, legislations, case precedents on legal aspects of whistle-blowers and corporate governance from the common law countries, i.e., Australia, United Kingdom, United States, New Zealand and Malaysia. The work also drew a comparison between conventional aspects of whistle-blowers and corporate governance to the injunctions of the Quran which would provide an Islamic perspective on aspects of whistle-blowers and good corporate governance.

3.0 LITERATURE REVIEW

Several case precedents involving whistle-blowing incidences were reported over the years.⁷ In one case in the U.S., there was a chemical technician called Karen Silkwood at the Kerr-McGee plant in Oklahoma. In 1974, Silkwood reported serious systemic health and safety infractions at the plant to the Atomic Energy Commission. In November of that year, due to her strongly discovery of malicious retribution for reporting the company, she set about testing positive for plutonium contamination. On the same month, she met with a New York Times reporter with all of her documentation she had collected. On the way there, she was involved in a mysterious car accident that killed her. The cause of the accident has never officially been confirmed. Due to whistle-blowing act, she was killed.

Another case of whistle-blowing reported in 2002 with regard to the company's numerous fraudulent attempts to

⁷ Example of famous whistle blowing cases. <<http://www.investopedia.com/financial-edge/01/12/whistle-blowers-and-their-impact-on-business.aspx>>. Accessed on 1 Mac 2018.

falsify the financial statement, when Sherron Watkins, a vice president of the multi-national Enron Corporation, testified before a Senate committee of the said fraudulent financial statement. This scandal led to the discovery of one of the largest corporate failures in history. Another one of the major whistle-blowing cases will be the fuel efficiency defeat device in Volkswagen.⁸ It seems that not a single employee from Volkswagen tried to whistle blowing about the defeat devices used to cheat the fuel economy during the test drive. However, once the issue become widespread, more employees starting to whistle blow on this. This might be due to the culture of the organization. Apparently the same fueleconomy defeat device was used by Volkswagen back in 1973 and been fined for \$120 000. Therefore, it could be the culture, policies and processes in the organization whereby the wrongdoings are considered as normal.⁹ This results in fear in the employees in order to whistle-blowing as they might lose their jobs.

In 2012, well-known case of whistle-blowing involves GlaxoSmithKline with staggering and the record setting lawsuit of \$3 billion.¹⁰ Phillips & Cohen, LLP two of the whistle-blowers provided the government with irresistible evidence that was at the heart of the government's case against GlaxoSmithKline. Glaxo's settlement is regarded as the largest Medicare fraud which ever made, and the largest settlement of a whistle-blower. Another whistle-blowers, namely Thomas Gerahty, a former senior marketing development manager for Glaxo, and Matthew Burke, a former regional vice president for Glaxo had also provided precious insider information that the London-based pharmaceutical company was engaging in corrupt nationwide schemes to push sales of Advair, Wellbutrin, Imitrex and other popular prescription drugs for "off-label" (unapproved) uses, that it used improper financial inducements to market its drugs, and that it misrepresented the safety and efficacy of those drugs. Glaxo's illegal practices caused Medicare, Tricare – the healthcare program for the military and Medicaid to incur huge losses.

In the Enron's case, Sherron Watkins had exposed the malpractices and wrongdoings of one of the biggest corporation in the United States. This led to the collapsed of Enron Corporation in 2002.¹¹ Sherron Watkins worked as an accountant at Enron then. She had warned her chairman, Kenneth Lay about accounting practices in the company in early 2001 when she discovered that Andrew Fastow, the Chief Financial Officer, operated a complex off-the-book structures which obscured the fact that the company was owed hundreds of millions of dollars. Instead of investigating her concerns, Kenneth Lay terminated her contract. The incident was reported in November 2001 where it appeared that the company had overstated its profits by \$600 million. For her exemplary deed, Sherron Watkins was named as one of the "Persons of the Year" in 2002 as reported by the Times.¹² Also in 2004, David Franklin, a scientist working at Pfizer won a \$27 million settlement in a lawsuit with regard to encourage the doctors to prescribe a drug for unapproved use against the company of defrauding Medicaid.¹³ The most recent case that shocked the world was when Edward Joseph Snowden, a former CIA employee leaked classified and restricted information to the public from the United States National Security Agency in 2013.

It can be highlighted that from the year 2001 onwards, the corporate sector witnessed the collapse of few corporate giants in the United States and Europe, namely, Enron,¹⁴ WorldCom,¹⁵ Parmalat¹⁶ etc. These corporate failures revealed that the companies' financial statements were tempered by 'creative accounting', fraud and corruption. This could have been avoided if the malpractices or frauds were reported to the relevant authorities at the early stages by the whistle-blowers.

On the local scene, Datuk Zarina Anwar who was the ex-Chairman of the Securities Commission of Malaysia stated that "Whistle-blowing is a term used to describe the disclosure of information that one reasonably believes to be evidence of contravention of any laws or regulation or information that involves mismanagement, corruption or abuse of authority. The whistle-blower is like the referee in a football game, using his/her whistle to call a foul."¹⁷

⁸ Whistle blowing challenges in VW: <<http://richardbstrong.com/vw-challenge-whistleblowing/>>. Accessed on 1 Mac 2018.

⁹ Whistleblowing challenge – VW case: <<https://www.whistle-blowersecurity.com/blog/the-whistleblowing-challenge>> Accessed on 1 Mac 2018.

¹⁰ GSK fraud whistleblowing – largest medicare fraud. <<http://www.phillipsandcohen.com/2012/Whistle-blowers-played-major-role-in-Glaxo-case-leading-to-Glaxo-s-record-settlement.shtml>>. Accessed on 1 Mac 2018.

¹¹ Ainsworth, John, "Whistle-blowing: The UK Experience", *MAICSA Annual Conference 2007*, Nikko Hotel, Kuala Lumpur, 16 & 17 Jul. 2007.

¹² Sherron Watkins was named as the "Persons of 2002" together with other two whistle-blowers i.e. Cynthia Cooper of WorldCom and Coleen Rowley of the FBI.

¹³ O'Donnell, *loc. cit.*

¹⁴ American's energy company based in Houston, Texas. Enron's stock price falls from \$70 (in January 2001) to \$0.26 (in November 2001) before it was suspended from the New York Stock Exchange on 15 January 2002.

¹⁵ The United States' second-biggest long-distance phone company and the largest mover of internet traffic.

¹⁶ Italy's eighth-largest food industrial empire.

¹⁷ Zarina Anwar, "Whistle-blowing: Subversive Spy or Responsible Corporate Citizen?", *Regional Conference on Agenda for the 21st Century – Revitalising the Corporation*, JW Marriot Hotel, Kuala Lumpur, 29 Sept. 2003.

Under the Malaysian context, we have seen several reported cases of accounting irregularities of committed by listed corporations, for example, Transmile Group Berhad¹⁸ and Megan Media Holdings Berhad,¹⁹ Energro, Pasaraya Hiong Kong, GP Ocean and Nasioncom.²⁰ These companies were highlighted by Datuk Zarina Anwar where she stated that “We have seen this happen here over the last few years with the likes of Energro, Pasaraya Hiong Kong, GP Ocean and Nasioncom and now more recently Transmile and Megan Media. Our response to these developments is very clear – the SC will take swift and firm enforcement actions against the perpetrators. As evidenced by our enforcement record, we have instituted actions against company directors, auditors, corporate advisors and management. There is a range of enforcement powers available to the SC and I will be very clear – we will use all these powers and leave no stone unturned in our investigative and enforcement efforts, to come down hard on any one that abuses our market. I am heartened to note that many aspects of our existing framework for corporate governance and financial reporting has played a key role in maintaining high overall standards that have been acknowledged internationally. Our whistle-blowing provision, for instance, has played a key role in assisting the SC’s enforcement efforts.”

In Malaysia, it was reported recently that Dr Syed Omar Syed Agil, 56, had sought protection as a whistle-blower for allegedly exposing the financial improprieties of his colleagues at Institut Profesional Baitulmal Sdn Bhd (IPB).²¹ This was the first such case in Malaysia to seek relief under the WPA 2010 through a court process. The High Court Judge, Justice John Louis O’Hara ruled that IPB failed to prove that the detrimental action taken against the plaintiff was not in reprisal for his (Dr Syed Omar) disclosure to the anti-graft body and the police.

3.1 The Whistle-Blowers’ Dilemma And Challenges

It is important to discuss the problems faced by the whistle-blowers. The act of whistle-blowing is not an easy task. In fact, only very few people dare to whistle-blow. In the case of an employee, who has access of information of a company, whistle-blowing would inevitably draw retaliation from the management of the company. As described succinctly by Datuk Zarina Anwar, “Let us face it – it is not easy for the whistle-blower to disclose information on the abuse, mismanagement or corruption that he/she believes is taking place within the work environment especially if the transgressors are people that he/she knows and works closely with ... The general impression of a whistle-blower thus becomes someone who is not a team player, who has the need for personal aggrandizement, or has a strong sense of paranoia.”²²

A whistle-blower may face one of the following problems:

- a) their action is deemed to be disloyal to the company they work with;
- b) risk of not able to find a job when labelled as whistle-blower
- c) risk of being dismissed and losing his/her job;
- d) risk of being sued in the court for disclosing information;
- e) being discriminated by others as traitors by not being in the ‘team’; or
- f) denied promotion by their superior.

The stated problems faced by whistle-blowers above are not exhaustive. There are direct and indirect retaliatory actions that are faced by the whistle-blowers. Due to these reasons, many people despite having knowledge of the wrongdoings of a company choose to be silent. In the long term, the consequences of such attitude lead to severe consequences. It is against these backgrounds that the whistle-blower advocates strive for the law on whistle-blowing protection to be incorporated into the legal system to encourage whistle-blowing.²³

As reported in a survey conducted, more than 50% of the employees do not feel free and feel hesitate to express

¹⁸ The shares of Transmile Group Berhad fell from year-high of RM14.40 to year-low of RM3.36 within few months.

¹⁹ Megan Media Holdings Berhad is an optical data storage disc manufacturer which was classified as PN17 on 19 June 2007.

²⁰ See Speech by Datuk Zarina Anwar (Chairman of the Securities Commission): “Future Director of the Legal and Regulatory Framework for Malaysia’s Capital Market”, *MIBA Regional Capital Market Conference*, Nikko Hotel, Kuala Lumpur, 20 Jun. 2007.

²¹ Whistle-blower CEO wins suit. <www.thesun.com.my>. Accessed on 1 Mac 2018.

²² Zarina Anwar, “Whistle-blowing: Subversive Spy or Responsible Corporate Citizen?”, *Regional Conference on Agenda for the 21st Century – Revitalizing the Corporation*, JW Marriot Hotel, Kuala Lumpur, 29 Sept. 2003: “Undoubtedly, the whistle-blower will face the struggle between acting in the public interest and the sense of loyalty to management and colleagues. This struggle is heightened in an environment where the concept of overarching loyalty to superiors, colleagues and protection of the public image and reputation of the corporation is constantly re-enforced within the structures of the corporation. Whilst it may be useful for the organization to inculcate a corporate culture where the organization is viewed as a “team” or “family” for the purposes of increasing productivity and profitability and to effectively manage issues like compliance, integration and control, the downside is that it can alienate those who stand up to questionable practices.”

²³ Reports undertaken by the Organization for Economic Co-operation and Development (“OECD”) revealed that in most of the corporate disaster which have taken place, the employees were aware of the problems but too worried about damaging his/her jobs and raise the problems, or that they have raised their concerns but has been ignored.

out their opinions freely at workplace²⁴ because of fear of vengeance whereby any organizations foster a climate of “shooting the messenger” when any bad news is expressed by an employee. The employees are also concern of their job insecurity and as such it is best to “keep their mouths shut” whenever possible. Another factor would be lack of management responsiveness as their opinions were not be heard by the management team. Furthermore, a lack of openness between employers and employees has also brought the negative consequences, namely the problems go undetected, good ideas are never surfaced, the relationships between managers and employees criticize and the motivation declines because employees view their work as no longer worth their full psychological commitment.²⁵

Hence, it is important for the senior management to raise a spirit of openness in the work environment. From the past experience, most of the employees felt that they were ignored or embarrassed when they express the opinion particularly with regard to the whistle-blowing act. Thus, senior managers must willfully try very hard to ask for opinions and then listen carefully. The positive consequence from this action will increase the probability that the employees to report directly and open to new ideas as well. It is suggested that an organization can prepare the suggestion boxes to foster the openness in work environment. The employees may send their statement via suggestions box to the managerial level and this whole process will be done in private and confidential and is not open for discussion. Finally, active listening skills must be learnt by everyone in organization. Mostly communication between the parties breaks down due to insufficient listening skills. Listening is a censoriously important management skill that can help improve employees’ willingness to speak up. The managers must be fully psychologically engaged when listening to employees by maintaining efficient body languages, namely maintaining eye contact, nodding head at the appropriate times, and saying appropriate things in response to their words to build the confidence of the employees. Good body gesture will bring the trust and confident between the employees and employers.

Establishing and operating a good whistle blowing systems in countries with high level of corruption offer several challenges.²⁶ Companies around the world have responded to these challenges with a varying degree of success. The main challenges and solutions for having a well-functioning whistle blowing system are including universal access. The most basic challenge of a whistle-blower system is to provide easy access to those wishing to report. In doing so, companies face various challenges.

Second challenges for the whistleblowing related to the existence of clear and well known policies. After making them accessible, whistle-blower systems have to be well-known and accepted within the company. Many companies therefore use different information channels such as intranet, e-mails and information cards as well as regular training on compliance and ethics with the induction of new employees, company-wide training courses and special training for senior management to advertise whistleblowing systems and existing reporting mechanisms. Experience shows that while there might be cultural reservations towards whistleblowing, if communication is framed accordingly it does not lead to rejection or lower take-up (World Bank 2003). In general, a good policy should help to clarify the existing rules, reduce the fear whistle-blowers may have and create useful reports. Such policies should thus be integrated into the overall compliance policy of the company and provide a proper guidance on the whistleblowing such as type of issues, specifications, time frame involved and the channel.

The following challenges on the whistleblowing will be in managing and solving the reports. One of the major reservations against whistle-blower systems is that they produce large amounts of trivial or false reports. To deal with the high number of cases, companies need to use efficient screening and case management methodologies. This means defining different types, levels and degrees of formality of investigations, including criteria when no further action is required, as well as clear guidance and access for escalation and reporting to senior management and external bodies. Companies also face the challenge of balancing the wish of whistle-blowers for an anonymous or confidential reporting with the need for clarification of the information initially provided and the whistle-blowers’ expectation to receive feedback on the results of their reports. The use of external organisations/providers to manage whistleblowing systems is also seen as a possible solution to facilitate universal access while ensuring confidentiality and anonymity. Multinational companies also face the challenge that the same case can be reported through different channels in different regions. They should therefore share data and compare cases between different regions as far as data protection policy allows them. This data should also enable them to regularly evaluate their whistleblowing system, monitor the time it takes to resolve cases and detect patterns of problems or delays.

²⁴ Discovery survey. <<http://www.discoverysurveys.com/articles/itw-014.html>>. Accessed on 1 Mac 2018.

²⁵ Why whistleblowing is good? <<https://www.payscale.com/career-news/2014/01/why-being-a-whistle-blowing-employee-is-a-good-thing>>. Accessed on 1 Mac 2018.

²⁶ Whistleblowing in multinational companies: <http://www.transparency.org/files/content/corruptionqas/Best_practice_and_challenges_for_whistleblowing_systems_in_multinational_companies_2014.pdf>. Accessed on 1 Mac 2018.

3.2 Ramifications Of Whistleblowing

The act of whistleblowing could bring positive and negative ramifications. The effect of whistleblowing to the organization or society are as follows:

(i) Organization and Society

Whistleblowing will produce positive and negative results. Firstly, the act of whistleblowing may lead to the end of unethical business practices. This action could save most of the individuals and whole communities from untold financial, economic and even environmental losses. For example, pollution and damage to the environment has been reduced and subsequently stopped by the actions of one individual who “blew the whistle” on an unethical employer.²⁷ Furthermore, most of the businesses that engaged in unethical practices have been shut down because of the actions of whistle-blowers. For example, Ernie Fitzgerald, a whistleblower who exposed billions of dollars of cost overruns at the Pentagon, described whistleblowing as “committing the truth,” because employers often react as if speaking the truth about wrongdoing were tantamount to committing a crime.²⁸

(ii) Whistle-Blowers

Whistle-blowers who blew the whistle will face many consequences from their action including but not limited to possible firing, civil action or even being imprisonment. In other words, they could be victimized. In an organization, an employee has to follow the rule of “chain of command”, i.e., before an employee discusses the issues of whistleblowing with anyone else, he has to discuss the matter with his or her immediate supervisor first.

Whistleblowing mostly will bring good results in the society. However, it is undeniable that the blower will face negative consequences, such as ostracism, demotion, dismissal, reprimands, blacklisting as well as hardship and difficulty because of the possible resistance by those against whom the whistle is being blown.

In Islam tolerance was stated as a synergy. The Quran exhorts:

“... .. and forbid (people) from all that is evil and bad and bear with patience whatever befalls you, verily these are some of the important commandments ordered by Allah with no exemption.” (Qur’an, 3:110)

“O my son! Offer prayers perfectly, enjoin (people) to all that is good, and forbid (people) from all that is evil and bad and bear with patience whatever befalls you. Verily, these are some of the important commandments ordered by Allah with no exemption.” (Qur’an, 31:17)

One of the instances where whistleblowing was reported occurred during the reign of Caliph Umar (R.A). While delivering a sermon of Jumaat prayer in a mosque by Caliph Umar (R.A) who wore two wrappers, someone had questioned him where he got the second wrapper from. The issue was raised because the questioner was aware of the source of the wrappers, and the number allotted to each person. Umar, then, called his son, Abdullahi (R.A), to explain to the public that it was he (Abdullahi) who sacrificed his own share, due to the inadequacy of one wrapper for the rather tall Caliph Umar.

(iii) Ethical Perspective

The act of whistleblowing can cause conflict of interest between the individual, organizational and society. Many of the disagreement from the context that one views a whistle-blower, as person who shared knowledge of mismanage for the advantage of others or a person who acted disloyal to their organization. According to the ‘Broken Windows’ theory upheld by former New York Mayor, Rudolf Giuliani, communities will report or fix a broken window.²⁹ This implies correcting even the minute occurrences of wrongdoing, in this manner imparting comparable obligations in others and making a superior situation for all. Supporting whistleblowing inside organizations demands a culture of self-control and responsibility and that the management can guarantee security to the staff and business. The ethical perspective of whistleblowing can be seen from three perspectives, i.e., public perception, personal perception and corporate perception.

²⁷ Tom Devine, Tarek F. Maassarani, “The Corporate Whistleblower’s Survival Guide- A Handbook for Committing the Truth”, (2011): Berrett-Koehler Publishers, Inc., 4.

²⁸ *Ibid.*

²⁹ Broken Window theory: <<https://global.britannica.com/topic/broken-windows-theory>>. Accessed on 1 Mac 2018.

(iv) Public perception of ethics and whistleblowing

The act of whistleblowing can be a controversial issue. However, if businesses promote good corporate governance for all, whistleblowing does not need to be interpreted as negatively or as solely the preserve of business or community leaders. As per a survey done by the US Democracy Corps in 2007, it revealed that more than 70% voters supported whistle-blower protections. Among these voters, approximately 40% expressed their view that legislation to be enacted for the said protection.³⁰

(v) Personal perception of ethics and whistleblowing

The whistle-blower is ultimately uncertain between trustworthiness to their employer. The first impression is that they have the most to lose in a bureaucratic organization. This desensitizing environment could change the whistle-blower's perception of their relevance within a company or their ability to influence change, thus degrading their sense of responsibility and motivation to report. However, it is arguable that the whistle-blower should be brave to reveal such information if they are confident what they did is correct and motivated. The whistle-blowers and the media have enjoyed a synergetic relationship. Even they might have different agendas and purposes, they share the common ambition to expose wrongdoing and seek for changes in an organization or systems.

(vi) Corporate perception of ethics and whistleblowing

Some organizations provide a whistleblowing hotline in their workplace however they should not be satisfied when it comes to its usage and communication. A company should not assume that it is good news if the company does not receive many whistleblowing reports. Businesses have duties and responsibilities to the public including but not limited to governing bodies to act on whistleblowing intelligence or risk adverse consequences. Similarly, if there are environmental concerns arising from a whistleblowing report, these the company must address the issue with the correct authorities. However, from ethical context, some actions of whistleblowing could be considered as wrong cause of action. For example, the Republicans branded Bradley Manning, the Wikileaks informant, a terrorist and whipped the media and public into a frenzy regarding breaches of national security. Nevertheless, a culture of misconduct and corruption to infiltrate operations should not have occurred in any type of businesses.

3.3 WHISTLE-BLOWER PROVISIONS IN COMMON LAW JURISDICTION

3.3.1 Australian Corporations Law 2001

In Australia, the whistle-blower protection is stated under Part 9.4AAA of the Australian Corporations Law (hereinafter referred to as 'ACA') (Section 1317AA to Section 1317AE). The ACA which was introduced in year 2004 provides an extensive protection to whistle-blowers by having sections relating to prohibition of victimization, right to compensation and confidentiality requirements etc.

Section 1317AA(1)(a) of the ACA³¹ states that a 'discloser' which qualifies to be protected which includes an officer or employee of a company. It also covers the persons under contract for services or goods to the company. This section provides a wider range of persons protected compared to those under our CA/SIA/CMSA. Sections 1317AA(1)(d) and I of the ACA provides similar 'filters', namely the discloser must have reasonable grounds to suspect contravention of law and the discloser must make the disclosure in good faith. However, Sections 1317AA(1)(c) of the ACA has a peculiar requirement that the discloser must inform the person to whom the disclosure is made of his name before making the disclosure. It is opined that such sub-section is aimed to make sure that the discloser is a genuine one and not someone who make disclosure but keep his identity secret.

Section 1317AB of the ACA provides that states that a protected persons is not subject to any civil or criminal liability for making the disclosure.³² Our CA/SIA/CMSA provides that the protected persons shall be liable to be sued in any court. By interpreting the phrase "liable to be sued", one may argue that the protection is only in the area of civil action. If the intention was to include both civil and criminal action, the sections should read as "liable

³⁰ <<http://www.democracycorps.com/National-Surveys/>>. Accessed on 8 September 2018.

³¹ Section 1317AA(1)(a) states "the discloser is: (i) an officer of a company; or (ii) an employee of a company; (iii) a person who has a contract for the supply of services or goods to a company; or (iv) an employee of a person who has a contract for the supply of services or goods to a company."

³² Section 1317AB(a) states "If a person makes a disclosure that qualifies for protection under this Part: (a) the person is not subject to any civil or criminal liability for making the disclosure; and (ii) no contractual or other remedy may be enforced, and no contractual or other right may be exercised, against the person on the basis of the disclosure."

to be *sued or prosecuted*³³. In this sense, the Australian provision of Section 1317AB of the ACA is wider than the provisions in Malaysia, as it covers *civil and criminal actions*.

Section 1317AC of the ACA prohibits victimization of the discloser because of the disclosure made under the Act. It prohibits actual detriment and threatening to cause detriment to the discloser³³. This section protects the whistleblower from even a *threat*, which could be express or implied or conditional or unconditional³⁴. It is not necessarily to prove that the person threatened actually feared that the threat would be carried out³⁵. Such comprehensive provisions are not found in our CA/SIA/CMSA.

Section 1317AD of the ACA provides for compensation of damages to the victim.³⁶ The compensation provision is not provided under our CA/SIA/CMSA. The ACA took the whistle-blower protection even further by stating the confidentiality requirements under Section 1317AE of the ACA. A discloser who makes a qualifying disclosure to the specified officers of a company, the said specified officers are duty bound to keep the information and the identity of the discloser confidential at all time. The exception is that such disclosure is made to the relevant authority. Such provision is important for a company to establish an internal whistle-blowing system.

Whistle-blower legislation has already existed in Australia before the introduction of Part 9.4AAA of the ACA. The Public Interest Disclosure Act 1994 (Australian Capital Territory), the Protected Disclosure Act 1994 (New South Wales), the Whistle-blowers Protection Act 1994 (Queensland) and the Whistle-blowers Protection Act 1993 (South Australia) have already been enacted in different states in Australia since 1990's with the aim to protect the whistle-blowers from making public interest disclosure relating to maladministration, illegal conduct, corruption in the public sector. The ACA on the other mainly deals with the companies in relation to corporation's law.

The Australian provides an extensive protection to the whistle-blowers. There are important legislation relating to whistle-blower enacted since 1990's and the 2004 insertion of Part 9.4AAA to the ACA further strengthen the protection of whistle-blower in Australia.

3.3.2 Public Interest Disclosure Act 1998 Of United Kingdom (Pida)

Whistle-blower in the United Kingdom is protected under the PIDA. Section 47B of the PIDA provides that a worker (including employee) has the right not to be subjected to any detriment by any act, or any deliberate failure to act, by his employer done on the ground that the worker has made a protected disclosure.

The area of "qualifying disclosure" is defined rather widely which covers the areas under the employment law to protect the worker from any detrimental act, which includes the reasonable belief of the worker:

- (a) that a criminal offence has been committed, is being committed or is likely to be committed,
- (b) that a person has failed, is failing or is likely to fail to comply with any legal obligation to which he is subject,
 - I that a miscarriage of justice has occurred, is occurring or is likely to occur,
- (d) that the health or safety of any individual has been, is being or is likely to be endangered,
 - I that the environment has been, is being or is likely to be damaged, or
- (f) that information tending to show any matter falling within any one of the preceding paragraphs has been, or is likely to be deliberately concealed.³⁷

In the event a worker is subject to detrimental act because of the disclosure made, a complaint can be made to the employment tribunal claiming for compensation.

3.3.3 Protected Disclosures Act 2000 Of New Zealand

In contrast to the United Kingdom, New Zealand's Protected Disclosures Act 2000 ('PDA') provides wider protection to whistle-blower.

PDA protects an employee of a public and private sector for disclosing "serious wrongdoing" which includes:³⁸

³³ Section 1317AC(1) and (2) of the ACA.

³⁴ Section 1317AC(4) of the ACA.

³⁵ Section 1317AC(5) of the ACA.

³⁶ Section 1317AD states "If (a) a person (the "person in contravention") contravenes subsection 1317AC(1), (2) or (3); and (b) a person (the "victim") suffers damage because of the contravention; the person in contravention is liable to compensate the victim for the damage.

³⁷ Section 43B of the PIDA.

³⁸ Section 3 of the PDA.

- (a) an unlawful, corrupt, or irregular use of public funds or public resources;
- (b) an act, omission, or course of conduct that constitutes a serious risk to public health, public safety, or the environment;
- (c) an act, omission, or course of conduct that constitutes a serious risk to the maintenance of law, including the prevention, investigation, and detection of offences and the right to a fair trial;
- (d) an act, omission, or course of conduct that constitutes an offence; and
- (e) an act, omission, or course of conduct by a public official that is oppressive, improperly discriminatory, or grossly negligent.

It is argued that the definition of 'serious wrongdoing' is wide enough to cover any breach or non-performance of the laws concerning company laws despite the fact that it is not defined expressly under Section 3 of the PDA. The PDA is a very liberal Act as it also covers the public sector whistle-blowing. Disclosure of serious wrongdoing could be made against a company or even the governmental agencies. G. Gunasekara³⁹ stated that "... the New Zealand legislation is also consistent with New Zealand's well-established climate of open government. It also helps to counter a common misconception that privacy is often protected at the expense of the public interest."⁴⁰

3.3.4 Sarbanes-Oxley Act 2002 Of United States

One of the most significant developments for whistle-blower protection is the enactment of the Sarbanes-Oxley Act 2002 ("SOA") in the United States. It is an Act to protect investors by improving the accuracy and reliability of corporate disclosures made pursuant to the securities laws in the United States. The SOA was enacted in the wake of many corporate failures which whipped out millions of dollars of the investors and when the market confidence on corporate governance is low. Title VIII of the SOA entitled "Corporate and Criminal Fraud Accountability" provided, *inter alia*, the protection to the whistle-blowers. Whistle-blowing protection for employees of a publicly traded company is provided in Section 806 of the SOA⁴¹.

It should be noted from the outset that Section 806 of the SOA is aimed to protect the whistle-blowers in providing information in *fraud cases*. Section 806 of the SOA protects the "employees" of a company from any act of "discharge, demote, suspend, threaten, harass, or in any other manner discriminate against an employee" by the company or any officer, employee, contractor, subcontractor, or agent of such company.

The SOA gives wider protection towards the employees in terms of the retaliatory action that could be taken against the whistle-blower. The SOA protects the whistle-blowers from any act of "discharge, demote, suspend, threaten, harass, or in any other manner discriminate against an employee".

The SOA also gives a wider protection where it prohibits retaliatory action by the "*company or any officer, employee, contractor, subcontractor, or agent of such company*". For example, the company could direct a third party to harass the whistle-blower and this will not be protected under the SIA. In addition, Section 806(b) of the SOA⁴² provides for *procedure of the enforcement action*. The similar provisions are not provided under the CA/SIA/CMSA.

³⁹ Lecturer in Commercial Law, University of Auckland, New Zealand.

⁴⁰ G. Gunasekara, 'Whistle-Blowing: New Zealand And UK Solutions To A Common Problem' (2003) 24 Stat. LR 39.

⁴¹ Section 806(a) of the SOA states, *inter alia*, "Whistle-blower Protection for Employees of Publicly Traded Companies – No company with a class of securities registered under section 12 of the Securities Exchange Act of 1934 (15 U.S.C. 781), or that is required to file reports under section 15(d) of the Securities Exchange Act of 1934 (15 U.S.C. 78o(d)), or any officer, employee, contractor, subcontractor, or agent of such company, may discharge, demote, suspend, threaten, harass, or in any other manner discriminate against an employee in the terms and conditions of employment because of any lawful act done by the employee—(1) to provide information, cause information to be provided, or otherwise assist in an investigation regarding any conduct which the employee reasonably believes constitutes a violation of section 1341, 1343, 1344, or 1348, any rule or regulation of the Securities and Exchange Commission, or any provision of Federal law relating to fraud against shareholders, when the information or assistance is provided to or the investigation is conducted by - (A) a Federal regulatory or law enforcement agency; (B) any Member of Congress or any committee of Congress; or (C) a person with supervisory authority over the employee (or such other person working for the employer who has the authority to investigate, discover, or terminate misconduct); or (2) to file, cause to be filed, testify, participate in, or otherwise assist in a proceeding filed or about to be filed (with any knowledge of the employer) relating to an alleged violation of section 1341, 1343, 1344, or 1348, any rule or regulation of the Securities and Exchange Commission, or any provision of Federal law relating to fraud against shareholders."

⁴² Section 806(b) of the SOA states, *inter alia*, "Enforcement Action. — (1) In general. — A person who alleges discharge or other discrimination by any person in violation of subsection (a) may seek relief under subsection (c), by— (A) filing a complaint with the Secretary of Labour; or (B) if the Secretary has not issued a final decision within 180 days of the filing of the complaint and there is no showing that such delay is due to the bad faith of the claimant, bringing an action at law or equity for de novo review in the appropriate district court of the United States, which shall have jurisdiction over such an action without regard to the amount in controversy. (2) Procedure - (A) In general - An action under paragraph (1)(A) shall be governed under the rules and procedures set forth in section 42121(b) of title 49, United States Code. (B) Exception - Notification made under section 42121(b)(1) of title 49, United States Code, shall be made to the person named in the complaint and to the employer. (C) Burdens of proof - An action brought under paragraph (1)(B) shall be governed by the legal burdens of proof set forth in section

The first decision under the SOA in the United States was reached in the case of *Welch v Cardinal Bankshares Corp*⁴³. The administrative law judge concluded that the complainant was terminated in retaliation for disclosing accounting irregularities. However, the provisions in the SOA are not perfect either. It was reported in the *Wall Street Journal* in year 2004 that over three hundred individuals have filed claim with the United States Department of Labor's Occupational Safety & Health Administration ("OSHA") and 56% of the complaints have been dismissed by the OSHA. The complainants withdrew the complaint in 12% of the cases and 20% are still pending. Only 12% of the cases where the OSHA found reasonable cause to believe that the complaint had merit.⁴⁴

Since the SOA came into force, there are many cases that have been filed in the United States. In *Hopkins v ATK Tactical Systems*⁴⁵ it was held that the complainant's disclosure of allegedly illegal release of sludge water into ground water system was not protected as it did not constitute a fraud on shareholders. In *Lerbs v Buca Di Beppo, Inc.*⁴⁶ the court stated that for a whistle-blower disclosure to be protected, the reported information must have a certain degree of specificity, general inquiries about the propriety of certain transactions without identification of particular concerns was insufficient. In *Halloun v Intel Corp.*⁴⁷ it was held that belief that an activity was illegal may be reasonable even when subsequent investigation proves a complainant was entirely wrong. In *White v Burlington Northern & Santa Fe Railway Co.*⁴⁸ retaliatory action was stated to mean any adverse treatment that is based on the retaliatory motive and is reasonably likely to deter a charging party or others from engaging in protected activity of whistle-blowing. In *Collins v Beaser Homes, USA, Inc.*⁴⁹ it was held that the burden of proof is on the plaintiff to show that the plaintiff's protected activity was a contributing factor in the unfavorable action alleged in the complaint.

It is pertinent to note that the provisions cater for an early warning system for malpractice and wrongdoing in a company. Gregory R. Watchman⁵⁰ stated that "Institution with effective whistle-blower programs can use such programs to identify internal problems early, minimize the harm resulting from such problems, protect their institutional integrity, and preserve their reputation in the larger community. In this sense, the focus on corporate governance accountability stemming from the many business scandals of the past several years has brought not only regulatory mandates, but a true opportunity for corporate leaders to 7organizat and take advantage of this critical early warning system."⁵¹ On the collapse of Enron, Kirstine Drew⁵² stated a number of lessons to be learned i.e. accounting practices, anti-bribery enforcement, *whistle-blowing*, political connections and donations to political parties, corporate compliance programs etc.⁵³

3.3.5 Whistle-Blower Protection Act 2010 Of Malaysia

Despite the introduction of various legal frameworks, whistleblowing in Malaysia remains rare in comparison to the number of complaints received by various enforcement agencies. Figures presented in Table 1 show that, in 2012, out of a total of 8,953 complaints received by the MACC only 28 were from whistleblowers. For the Police, out of a total of 1,475 complaints, 67 were from whistleblowers.⁵⁴ Considering the importance of whistleblowers in discovering cases of fraud, as exemplified by the U.S., these numbers suggest whistleblowers in Malaysia remain hesitant. Meanwhile, figures presented in Table 2 also show that the number whistleblowers in Malaysia remain timid.

Table 1: Number of whistleblowers complaints to various Malaysian enforcement agencies in 2012⁵⁵

Agency	Number of Complaints Received	Number of Whistleblowers
Royal Malaysian Police	1,475	67
MACC	8,953	28
Kastam	375	0

42121(b) of title 49, United States Code."

⁴³ No 2003-SOX-15 (July 19, 2004).

⁴⁴ "For Financial Whistle-Blowers, New Shield is an Imperfect One", *Wall Street Journal*, 4 Oct. 2004.

⁴⁵ 2004-SOX-19 (ALJ May 27, 2004).

⁴⁶ 2004-SOX-8 (ALJ June 15, 2004).

⁴⁷ 2003-SOX-7 (ALJ March 4, 2004).

⁴⁸ Fed. App. 0101P (6th Cir. April 14, 2004).

⁴⁹ 2004 WL 2023716 (N.D. Ga. September 2, 2004).

⁵⁰ Executive Director of GAP.

⁵¹ Watchman R. Gregory, *loc. cit.*

⁵² Public Services International Research Unit (PSIRU), University of Greenwich, London.

⁵³ Drew, Kristine, "Enron – The Foreign Corrupt Practices Act & The OECD Convention", *Public Services International Research Unit's Website* <<http://www.psiru.org/reports/2002-03-C-Enron.doc>>. Accessed on 19 March 2018.

⁵⁴ MACC Annual Report, 2012

⁵⁵ The latest MACC Annual Report available online is for 2012.

JPJ	737	1
Imigresen	125	0
SC	447	0
SSM	1,895	2

Sources: <http://www.sprm.gov.my/index.php/en/corporate-info/resource-centre/annual-reports/book/230-macc-annual-report-2012/31-annual-report>.

Table 2: Whistleblower Protection Act 2010 (Act 711) Implementation Report

YEAR	2011	2012	2013	2014	2015	2016	2017*	TOTAL
COMPLAINTS RECEIVED	1,690	14,007	12,333	12,722	12,527	7,507	2,066	62,852
WHISTLEBLOWER	17	98	69	208	4	50	27	473

*Updated Date: August 2017

Sources: <http://www.bheuu.gov.my/index.php/en/statistics/statistics-for-implementation-of-the-whistleblower-protection-act-2010>.

The United Kingdom's (UK) Public Interest Disclosure Act 1998 (PIDA) (UK Legislation, 1998) and the Employment Rights Act 1996 (ERA) (UK Legislation, 1996) which require the whistleblower to act in good faith and both do not extend protection to persons related to or associated with the whistleblower. Whereas, the Malaysian WPA 2010 Act extends its jurisdiction down to the state level, provides fiscal incentives and penalties as well as extending protection to persons related to whistleblower. While the Act in Malaysia may be said to be more comprehensive than similar legislation in these other countries gaps still remain. The whistleblowing mechanism still has shortcomings. Further modifications can strengthen the Act and increase the independence of the whistleblowing process.

4.0 ISLAMIC PERSPECTIVE OF WHISTLEBLOWING

One of the main components in Islamic whistleblowing⁵⁶ which has been practiced and sanctioned in the Islamic political culture by Prophet Muhammad. The objective of whistleblowing is to promote truth and saving the society from being harmed and to emphasize the business ethics in organization or government establishment. In fact, the central message for Islamic teaching involves with ethics which is in line with these conventional motives of whistleblowing. This can be seen from the verse:

"It is not righteousness that ye turn your faces to the East and West, but righteous is he who believeth in Allah and the last day and the angels and the scripture and the prophets, and giveth his wealth for lone of him, to kinsfolk and orphans and the needy and the wayfarer and to those who ask, and to set slaves free and observeth proper worship and payeth the poor-due. And those who keep their treaty when they make one, and the patient in tribulation and adversity and time of stress such are those who are sincere, such are the God fearing."
(Qur'an, 2:177).

This multi-dimensional system of Islamic ethical values also can be seen from the famous Hadith of the Apostle of Allah, whilst He (the prophet) refers to the whole religion as a set of ethics. Where it was reported that:

Prophet Muhammad (saw) said "I was sent to complete the set of ethics" and "The best Jihad is the word of truth against a tyrant ruler". (Abu Dawud, Tirmidhi, Ibn Maja)⁵⁷

Thus, we can see that there is no room for egoism in Islamic ethical values as manifested in the concept of relativism, no room for profit maximization as in the micro economic approach, and no room to the ideology of "the end justifies the means" as in the universalism. The goal Islamic willing to achieve by ethics is the refinement and purification of soul, as explained by Ghazali "ethic is the characteristics and moral constitution of soul"⁵⁸ (Ashraf, 1963). The main features of Islamic ethics are at the same time, the means of soul purification and refinement, Unity, equilibrium, freewill, responsibility and benevolence. In Quran chapter 68:4, Allah (SWT) describes about His Apostle:

"And verily, for you (O Muhammad) are an on exalted standard of character." (Quran, 68:4)

This verse impliedly defined ethics as standard character. And once again Allah describes about being truthful and not hiding the wrongdoings in his verse below

⁵⁶ Whistleblowing from Islamic perspective: <<http://www.gamji.com/article4000/NEWS4501.htm>>. Accessed on 1 Mac 2018.

⁵⁷ The need for muslim whistle-blowers reviving a prophetic tradition. <<http://5pillarsuk.com/2013/07/25/the-need-for-muslim-whistle-blowers-reviving-a-prophetic-tradition/>>. Accessed on 1 Mac 2018.

⁵⁸ Ashraf, S. M. (1963) The faith and practice of Al-Ghazali, Kashmiri Bazar, LAHORE.

“And if you are on a journey and cannot find a scribe, then a security deposit [should be] taken. And if one of you entrusts another, then let him who is entrusted discharge his trust [faithfully] and let him fear Allah, his Lord. And do not conceal testimony, for whoever conceals it – his heart is indeed sinful, and Allah is Knowing of what you do.” (Quran, 2:283)

So what is the position of whistleblowing in Islam? In the teaching of Islam, whistleblowing is a lawful act in Islam and each of the Muslim has a duty and obligation to perform this obligation. However, from the perspective of Amru bil Maaruf, (enjoining goodness) Wal Nahyi an Al Munkar (forbidding wrongdoing) or from the point of view of Shahada (witness attestation) which is applicable in Islamic Law of Evidence, which is mandatory upon Muslims, then whistleblowing is a responsibility of a Muslim because the purpose of whistleblowing is the same as that of “enjoining goodness and forbidding wrongdoing supported by good witness attestation”. Whistleblowing is one of the three stages of Iman (faith), as narrated from Abi Saïd dil Khudri (R.A): I heard the prophet of Allah (P.B.U.H.) saying,

“He who saw Munkar (wrongdoing) amongst you should prevent it with his hand, if unable to, then with his mouth (i.e. whistleblowing), if unable to, then (dislike it) in his heart and that is the least of faith.”

This shows how big is the role of the whistleblowing in Islam. Jabir (R.A) Narrated a Hadith from the Holy Prophet (S.A.W.),

“Discussions are confidential (not subject to disclosure) except in three places: “Shedding unlawful blood, Unlawful cohabitation and Unlawful accumulation of wealth”.

Narrated by Abu Dawud. Another Hadith Narrated from Zaid Bn Khalid; the prophet (SAW) says:

“May I tell you who is the best witness? He who testify his witness before asked to do so”, hadith narrated from Zaid bin Khalid⁵⁹

According to Ibn Taymiya,⁶⁰ through this Allah indicated that His religion is perfected via His Messenger Rasulullah (p.b.u.h) who called towards goodness and forbade wrongdoings, made lawful only what is good (and pure) and prohibits people from what is bad (and impure). In other verses, Allah mentioned, *“You are the best nation brought forth for the people of the world; you enjoin right and you forbid wrong, and you believe in Allah”* (Al-Imran:110) *“The believers, men and women, are awliyyaa’ (helpers, supporters, friends, protectors) of one another: they enjoin good and forbid evil”*. (at-Taubah: 67) *“And Allah Most High said “Believing men and believing women are the protecting friends of each other: they enjoin right and they forbid wrong”* (at-Taubah:71) *“Let there arise out of you a band of people inviting to all that is good, enjoining what is right, and forbidding what is wrong: They are the ones to attain felicity”* (al-Imran:104).

The Prophet Muhammad (p.b.u.h) warned that permissive societies shall be punished with calamity; striking everyone without exception. Ibn Mas’ud reported that prophet Muhammad (p.b.u.h) said, *“There was never a messenger (from God) who did not have disciples, that is, Companions who did not work after him with the Book of God and Practice (of the Prophet) until the time after them that some people appeared who mounted the pulpits and spoke fine words, but committed filthy deeds. It is the right and religious obligation incumbent upon every believer to fight against them by hand; if one is not able, then in words; and if one is not able, in his heart, there is no Islam beyond this.”* (Muslim) In another hadith, Malik bin Dinar reported prophet Muhammad (p.b.u.h) said *“Allah Most High sent a revelation to an angel: “Overtum such and such a city.” (The angel) said: “O Lord God, How can I do this when such and such a person who has never committed a sin by even a winking of the eye is in there.” (Allah) said: „Do it, for he never once frowned at the sins of others.”* (Ibn Abbas, Tabrani, Baihaqi) Abu Bakar reported that prophet Muhammad (p.b.u.h) said *“There are no people in whose midst acts of disobedience are habitual, and who can change these habits but not change them, except that Allah visits them with a sweeping 72rganizati.”* (Abu Dawud, Tarmidzi, Ibn Majah)

Narrated by Aishah, prophet Muhammad (p.b.u.h) said, *“Allah punishes all the inhabitants of a land in which there were 17,000 men whose deeds were like the deeds of the Prophets.”* They asked: *“Why, O Rasulullah?”* He said: *“Because they were not angry at others for the sake of Allah Most High and they did not forbid their conduct.”* (Ibn Abi Dunya, Abu Syaikh, Ibrahim, Umar Sanai). Internal and external whistleblowing cases are very rare and practically no whistleblowing system and protection laws are in place. In the following discussion,

⁵⁹ Hadith related to whistleblowing. <<http://www.gamji.com/article4000/NEWS4501.htm>>. Accessed on 1 Mac 2018.

⁶⁰ Ibnu Taimiya. Enjoining Right and Forbidding Wrong, (Salim M. Trans). Retrieved from <<http://www.java-man.com/pages/books/alhisba.html>>. Accessed on 10 September 2018.

we will try to highlight how Islam views whistleblowing's five elements in light of al-Ghazali and Ibn Taymiya's treatises on the subject of *alhisbah* and good corporate governance can be useful and worthwhile to be adopted in Malaysia?

(i) The Guard

Al-Ghazali⁶¹ explained official mandate is needed the higher the degree of the guardianship responsibility. For instance, no official appointment is necessary when advising (first gently and then in stronger tones) a person against committing harm, or even when using physical force to stop the wrongdoer in this tracks. It follows that if all these fails, or are expected to fail, one would do better to report the wrongdoing to higher authorities, hence whistleblowing. According to Ibn Taymiya,⁶² the mandated authority should comprise possessors of political and temporal power, and the people of knowledge and intellectual influence. In turn, members of the "authority" must demonstrate certain qualities (i) knowledge (of the wrongful act and its implications) (ii) self-restraint and (iii) good nature. Ibn Taymiya gave two additional qualities (iv) gentleness and (v) patience. He also emphasized that hisbah, and by association, the whistleblowing report made, must only be done for the sake of Allah (in the interest of the public and not to gain attention or to exact revenge) and conforms to Shari'ah recommendations.

(ii) The information

Whistleblowing actions must concern with wrongdoing, or "*munkar*" which is anything that prohibited by Allah and His Messenger, including but not limited to criminal offenses or *73rgan* behavior. It includes also breaches of legal obligation or trust, miscarriages of justice, causing danger to health, safety or the environment. Essentially, Muslims are obliged to protect the interests of people from *harm* or *mafsadah* in particular with respect to the five basic needs: religion, life, intellect, lineage and wealth as established in the *maqasid al Shariah* framework. Imam al-Ghazali (d.505H) specified that the act must demonstrate four characteristics: (i) the act is reprehensible meaning it is prohibited by law or is indecent; (ii) the act is occurring or has occurred, meaning no report should be made based on suspicion alone; (iii) the act is observed without resorting to spying or intrusion of another person's privacy; and (iv) it is truly obvious that the act is improper, not based on suspicion or personal judgment.

(iii) The Procedure

From Muslim history during the four pious Caliphs⁶³ (*Al-Khulafa-ur-Rashidun*), we learn that the public are free to voice their problems direct to the Caliphs or the governors of the region. In fact, the primary responsibility of our current governance should be the same as it was in the days of the early Caplihs, i.e. to make and follow the law in accordance with the teaching of Qu'ran and the Sunnah, to secure impartial and speedy justice for all nations and to strive hard in the path of God. As such, in responding to the report about a wrongful act, the authorities must make every effort to uncover the actors leading to such behaviour, give proper counsel and sort out the underlying grievances of the perpetrator. Failing which, stronger methods can be employed to stop the act or punish the perpetrator.

(iv) The protection

"*Keep up prayer and enjoin the good and forbid the evil, and bear patiently that which befalls you; surely these acts require courage.*" (al-Lukman:17) The above verse cautions would be whistleblowers to anticipate retribution or rebuke and therefore, he should be strong for indeed Allah will reward him, and he is the Most Just. Al-Ghazali described three types of retribution, which we can draw inspiration from to help determine suitable responses. Firstly, the whistleblower should make the report even if it means possible loss of income or discrimination, except when the deprivation is immediate and he cannot cope with it. Secondly, the whistleblower need not make the report if there is strong reason to believe that the retaliation will involve major physical and financial loss, that is not tolerable with his existing ability and circumstances. The final type of retribution is one that causes hamon family members and relatives. If there is genuine risk someone can hurt his family to revenge his incriminating testimony to the authorities, he should not proceed to whistleblow. According to al-Ghazali, "*to endure (the troubles) with respect to himself is lawful, but not with respect to others.*" Similarly, Ibn Taymiya emphasized that a good act is obligatory only when its benefit outweighs its negative consequences.

⁶¹ Al-Ghazali (2002). Al-Ghazali on enjoining good and forbidding wrong (Muhammad Nur A. S, Trans). In Seyyed Hossein N. (Ed.). Chicago: Great Books of The Islamic World.

⁶² Ibnu Taymiya (1987). Public duties in islam, the institution of the hisbah (Mukhtar H., Trans.). Khurshid A. (Eds.). United Kingdom: The Islamic Foundation.

⁶³ They are the first four Caliphs: Abu Bakr, 'Umar, Uthman and Ali. They lived simple and righteous lives and strove hard for the religion of God. Their justice was impartial, their treatment of others was kind and merciful, and they were one with people- the first among equals.

5.0 RECOMMENDATION

Whistleblowing practices should be considered a part of organization's management system in handling misconduct activities occur within an organization. Employers can also play an important role in supporting whistleblowing practices in the organization as a way to report wrong doing and manage risks to the organization. Moreover, they also need to be well prepared for controlling any such concern raised by workers. Hence, these are some the best practices that employer can do to support whistleblowing:

- Have an appropriate written procedure in place for whistleblowing policy.
- Workers are easy to access to the whistleblowing policy / procedures.
- Raise awareness of the policy or procedures in workplaces for all the workers.
- Ensure the organization's whistleblowing policy or procedures clearly identify who can be approached by workers that want to raise a disclosure. Organisations should ensure a range of alternative persons who a whistle-blower can approach in the event a worker feels unable to approach their manager.
- Ensure that all disclosures raised will be dealt with appropriately, consistently, fairly and professionally.
- Until and unless required by law to reveal it, the identity of the worker raising a disclosure should be protected and to offer support throughout with access to mentoring, advice and counseling.
- Create an organizational culture where workers feel safe to raise a disclosure in the knowledge they will not facing any harm from the organization as a result of speaking up.

Last but not least, the notion where whistle-blowers are traitors needs to stop because, as a Muslim, we should take and learn examples shown by Prophet Muhammad (s.a.w) and practice it in our daily life where there were lots of proofs and example explained in hadith and Quran that mentioned about the practices. Even though it does not specifically mention on whistleblowing, but the concept related to *amr ma'ruf nahi mungkar* is there. Thus, all the Muslim, including ulama and Islamic organisations including the 'National Oversight and Whistle-blowers Centre' are to be advised and encouraged to make whistleblowing more organized, professional and structured. All civil-minded citizens of Malaysia must also give fully moral support to this excellent initiative.

6.0 CONCLUSION

In conclusion, many countries have started to pay attention to the importance of whistle-blowing by enacting the relevant legislations to protect whistle-blowers and at the same time to promote good governance within both the public and private organizations. Whistle-blowers in Malaysia are protected by the "Whistle-blower Protection Act 2010" (WPA), which came into force on 15 December 2010, has shown its commitment in eliminating corporate fraud, corruption and misbehavior through the enactment of the WPA 2010. It is submitted that there is still a bridging gap between whistle-blower protection and good corporate governance practices in Malaysia compared to common law and civil law countries. This is due to the shortcomings of the WPA 2010 in encouraging whistleblowing in large corporations is to overcome the exclusion of internal whistle-blowing from the scope of the WPA 2010. It is suggested that Malaysian Parliament would rectify the weakness of the WPA 2010 to ensure that the whistle-blower protection in Malaysia would be in line with the international standards in this area. Strengthening wider protection for whistle-blowers would promote good corporate governance in Malaysia. As a result, this would prompt greater investors' confidence and attract a steady flow of investment funds into Malaysia (Low et al., 2011).

Islam recognizes any profession that does not contradict its teachings, irrespective of where it comes from, and any profession that encourages moral conduct in any endeavour of life, (if called Islamic) one could not be wronged. Islam has a base for anything and everything that exists can be distinguished as either halal (lawful), haram (unlawful), makruh (disliked), mustahab (recommended) or mandub (optional). Whistleblowing in a business organization that has the motive of bringing prudence, transparency and accountability is not only halal (lawful) but also wajib (obligatory) depending upon what the condition warrants.

Leader, managers and anybody in the position of authority should practice whistleblowing. However, the necessary protection should be given to the blowers and they must be treated positively. Whatever information brought by them must be investigated fairly before any necessary action to be taken considerately. As in the case of one of the companion of the Holy Prophet during the reign of Caliph Umar (R.A). It was reported to Umar that; one of the companion of the Holy Prophet was into excessive alcohol drinking at sham (Syria), then Umar wrote a portion of the initial part of Suratul Gafir and up to... the forgiver of sin, the accepter of repentance, the severe in punishment, the Bestower (of favours), None has the right to be worshipped but He, to Him is the final return

(Qur'an 40: 1-3). The lesson attached to this, is that, when the whistle is blown, the first thing is to scold or remind the wrong doer, then if he persists, appropriate action should be taken. Although, when such action has an effect on the public, punishment must be done instantaneously.

REFERENCES

- Ainsworth, John(2007). *Whistle-blowing: The UK Experience*, MAICSA Annual Conference 2007, Nikko Hotel, Kuala Lumpur, 16 & 17 Jul.
- Al-Ghazali (2002). *Al-Ghazali on enjoining good and forbidding wrong (Muhammad Nur A. S, Trans)*. In Seyyed Hossein N. (Ed.). Chicago: Great Books of The Islamic World.
- Ashraf, S. M. (1963). *The faith and practice of Al-Ghazali, Kashmiri Bazar, LAHORE*.
- Deborah Solomon (2004). "For Financial Whistle-Blowers, New Shield is an Imperfect One", *Wall Street Journal*, 4 Oct.
- G. Gunasekara (2003). *Whistle-Blowing: New Zealand and UK Solutions To A Common Problem*, 24 Stat. LR (2003): 39.
- Ibnu Taimiya. Enjoining Right And Forbidding Wrong, (Salim M. Trans). Retrieved from <http://www.java-man.com/pages/books/alhisba.html>.
- Ibnu Taymiya (1987). Public duties in islam, the institution of the hisbah (Mukhtar H., Trans.). Khurshid A. (Eds.). United Kingdom: The Islamic Foundation.
- Khairunnisa Abd Samad and Haniza Khalid (2015). *Whistle-Blowing as an Aspect of Amar Ma'aruf Nahi Munkar in Institutional Governance*. International Conference on Aqidah, Dakwah And Syariah 2015 (IRSYAD2015), Kuala Lumpur, 12th – 13th October 2015.
- Low LT, Law KA, Ong SF (2011). Corporate Governance Assessment in Company Board Structure, *Afr. J. Bus. Manage*, 1175-1183.
- Pascoe, Jannie and Shanthi Rachagan (2005). Key Development in Corporate Law Reform in Malaysia, *Singapore Journal of Legal Studies*, 93-113.
- Tom Devine, Tarek F. Maassarani (2011). *The Corporate Whistleblower's Survival Guide- A Handbook for Committing the Truth*, Berrett-Koehler Publishers, Inc.
- Zarina Anwar (2003). Whistle-blowing: Subversive Spy or Responsible Corporate Citizen?, Regional Conference on Agenda for the 21st Century – Revitalising the Corporation, JW Marriot Hotel, Kuala Lumpur, 29 Sept. 2003.

ISLAMIZATION OF ACCOUNTING POLICY AS A SOLUTION TO THE ETHICAL PROBLEM IN ACCOUNTING

Saikou Gassama

University Of Airlangga Business and Economics

Abstract

There is a growing concern for accountant involvement in the continuous scandals which is due to the moral standards of some accountants and there are number of academics who suggest that the education system is to be partially blame. Ethical components in accounting education have been found to be insufficient and there is a lack of serious attention to tackle the problems in accounting. The objective of this paper is firstly to portray the significant of ethics in accounting education. Secondly, the paper argues for the direction of accounting education to focus on religious ethical development and values in developing accounting ethics specifically Islam. The paper further looked at the Islamic ethical perspective and how it provide some insights into the process of developing a more humanized and ethical accountant. This paper proposes the Islamization of ethical principle of accounting as a solution to ethical problems face by accounting profession, in a form of including Islamic ethics in accounting curriculums to be taught as part of the ethical accounting education process.

Key words: islamization, accountant, ethics, education, solution.

1.0 INTRODUCTION

Accountants owed an obligation to the society to explicitly communicate information for decision making. There is an increased fear that accountants, on several occasions, fail to give the required information requested by the users of their information, despite the existence of the professional ethics standards developed by the Institute of Management Accountants still some accountants act unethical (IMA) (Jajairam 2017). Also there is an increasing concern of the recent low unethical standards of some accountants. There is a growing intellectuals suggesting that the education system should bear some of the faults. They raised concerned for a need to looked at the kind of educational system that produces accounting professionals who, consciously or otherwise, appear to act unethically ethics is a set of principles or moral values (Yarahmadi and Hoyar 2015). Realizing the lack of ethical components in accounting education (Graham et al. 2013), this paper seeks to give a solution to the ethical problem in accounting profession and education system. The paper suggest that the solution to the ethical problems is in the adaption of religious ethical development and values in developing accounting ethics instead of just concentrating on the secular aspect of ethics and professional code of conduct. The paper proposed that the Islamic view and ethical perspective can provide solution to the process of developing a more responsible and ethical accountant. This paper also suggests the Islamic legal principles of sharia as an ethical mechanism to be considered as a method to solve ethical conflicts usually faced by accountants.

The paper therefor aims at tackling the fearless unethical and cultural unprofessional behavior of some accountant by inserting Islamic teachings and culture, Islam provides the ideological foundation for a variety of personal attributes that promote economic development (Salahudin et al. 2016), which have a significant influence on the lives of millions of people. also we hope here to encourage accountants to engagement and struggle to understand and apply Islam and development of Islamic law or Sharia to reflect dynamic principles of jurisprudence so as to contribute, in relation to the accounting focus, to conceptual development within Islam (Kamla, Gallhofer, and Haslam 2006). Accountants are also deemed as a watchman of financial markets. Without accountants to maintain quality and integrity of financial information, the markets for capital would be by far inefficient, the cost of capital would be higher, and the standard of living would be lower (Beattie 2000). As narrated in the previous part, this paper debates that accounting education has to include ethics as part of the integrated curriculum whereby from an Islamic point of view accountants need to free themselves from the secular world view which treats ethics as an ulterior aspect of professional and worldly life. This paper suggests an Islamic process of training accountants to be inculcate in accounting curriculum. Islam really views the work of accountants as significant to ascertain proper management of this world in order to achieve the ultimate blessing of God on the earth, in Islam, ethics governs all aspects of life. As stated by Prophet Muhammad (Peace be upon him) "I have not been sent except to perfect the ethical system" (Mahdavi-khou and Khotanlou 2012). In this section, the paper argues that in order for accountants to be able to act as moral judge in a business society they need to be trained with an Islamic ethical

mechanism. This is where the paper proposes the Islamic legal principles of as the basis of setting proper priorities for the work to be undertaken by the accountants. In this regard, accounting education has to be developed by instilling the proper stages of the ethical decision-making process that incorporate religious considerations and public interest.

This study suggests a capstone course on Islamic accounting ethics as a process to teach ethics in the accounting curriculum. The course can be taken by final year undergraduates in the final semester to consolidate and put into a proper perspective the knowledge of accounting techniques and professional values that they have acquired in the earlier studies. First, the importance of the Islamic worldview such as the Islamic belief, the role of men, and the pursuit of success that transcends beyond this worldly life, and others. This is important to expose students to the Islamic worldview and ethics and later on to relate all these principles to ethical problems in accounting. Secondly, the objective of the course should include to make students aware of rising issues facing the accounting profession and accountants. The AAOIFI's (Accounting and Auditing Organizations of Islamic Financial Institutions) code of professional conduct can be used as a material to explain and educate students to the attributes of ethical awareness and principles from an Islamic perspective.

Ethics education, needs to pay attention to at least three major issues. First, ethics should not be treated as just another subject that students learn about. Islamic ethics is of no exception and it should be taught as a subject where students can relate to comprehensive ethical dilemmas that they have encountered in the accounting curriculum as well as to potential ethical dilemmas that they might be facing when they join the accounting profession. Secondly, ethics education should not involve the uncritical assimilation of professional codes of conduct. Students need to be exposed to critical debates and discussions on the code of professional conduct and not to treat ethical codes as just written guidelines. There must be a proper education process for the students to internalize ethical principles. Finally, studying abstract ethical theory is not that important although a familiarity with broad ethical principles and concepts might be useful. The article argues that ethics education should attempt to humanize accounting students, that is, it should engender a sense of moral commitment towards other individuals. As rightly pointed by Mahdavihou and Khotanlou (2012), Islamic ethics should be introduced into accounting education and, in particular, emotional commitment to other individuals should be motivated. It is also proposed that increasing ethical commitment to other individuals may go some way towards fighting the attempt of accountants to loot other people.

2.0 CORPORATION OF ISLAMIC ETHICS IN ACCOUNTING

In the Islamic aspect, the only notable effort so far to establish a code of ethical conduct for accountants was developed by the Accounting and Auditing Organizations of Islamic Financial Institutions (AAOIFI) in 1998. The AAOIFI is a body established with the objective, among others, to develop, promulgate, and review accounting standards to be complied with by the member institutions. The rules of ethical conduct stated in this code shall apply to internal accountants, internal auditors and external auditors of Islamic financial institutions. The AAOIFI's code of ethical conduct for accountants presents an ethical framework for accountants derived from the Islamic Sharia rules and principles. The basic assumption of this code is that Muslim accountants will be motivated to comply with such a code for reasons due to religious beliefs and as a means of obeying Allah's orders and refraining from things forbidden by Him. In addition, accountants will be motivated to observe the ethical principles contained in the professional codes of ethics provided that the latter principles do not contravene the Sharia rules and principles. The code also aims to help in developing the accountant's ethical awareness by bringing to their attention ethical issues involved in professional practice. The accountant need to be teach about ethics that are based on religion so that they can see the duty as an obligation to be executed in honest manner.

The structure of the AAOIFI's code of ethical conduct consists of three sections; namely the Sharia foundations of accounting ethics, the principles of ethics for accountants, and the rules of ethical conduct for accountants. The Sharia foundations of accounting ethics delineate seven basic foundations; namely, integrity, sincerity, piety, righteousness, Allah fearing, and, accountability to Allah.

From these seven foundations, AAOIFI developed six basic ethical principles; namely, trustworthiness, legitimacy, objectivity, professional competence and diligence, faith-driven conduct, and professional conduct and technical standards. Finally, for all six ethical principles, they developed guiding rules for accountants in their professional works. A critical evaluation of the AAOIFI's code of ethical conduct will show that having a code is not a solution to the ethical challenges faced by accountants. The AAOIFI's code of ethical conduct will be of use as a guide to Muslim accountants and accounting students. However, the code of ethical conduct cannot and does not intend to provide an operational guide for, or impact ethical awareness among accountants and accounting students. Empirical studies need to be undertaken to explore the acceptance of this code especially among

accountants and auditors of Islamic financial institutions that have adopted the AAOIFI's code of ethical conduct as their guide.

3.0 ETHICAL ISSUES AND CAUSES OF ETHICAL FAILURE

The numerous scandals cause the public to question the trustworthiness of accountant, why some run businesses honestly and others turn into criminals. Despite appearance of number of scandals, the causes of unethical accounting practices are complex and interconnected. Some may attempt to rob the corporation, while others are drawn into illegal practices gradually through ignorance or good intentions.

Greed; at the root of a complex matter is a very simple fact: Some people enjoy having lots of money and will break the law to get it. Accounting, whether it is on an individual basis or within the context of a multinational corporation, offers the opportunity to "cook the books" and take a little or a lot more for yourself without actually pointing a gun or breaking into someone's house.

Opportunity; Accounting sometimes involves dealing with very large amounts of money, some of which can be easily hidden, siphoned off or removed with little chance of detection. When presented with this level of temptation, some people succumb, particularly if they perceive themselves to be in a situation of financial need.

Pressure to Manipulate the Figures; accountants are always under great deal of pressure, especially when things are not going well with the business. This increase the temptation accountant to fudge the numbers just to provide impressive report. It's a real problem for accountants, whether they're employees or an outside firm you've hired.

Omission; an accountant also feel pressure to simply leave things out of financial reports if they'd cast a shadow over the company. This is the flip side of actively misrepresenting numbers, and psychologically it might feel easier.

Confidentiality Issues; like doctors and lawyers, accountants naturally spend much of their time dealing with confidential information. Using that information inappropriately, or failing to protect confidential information properly, are both ethical issues for an accountant.

Conflicts of interest can be an especially difficult ethical issue to recognize. If your senior accounting staff receives bonuses based on the stock price, for example, they have a motivation – consciously or unconsciously – to make decisions that favor higher stock prices, even if they're not good for the company or its investors in the longer term.

Ethics instruction has increasingly become an established component of accounting education. Concerns about the level of unethical behavior in practice serve as the impetus for the integration of ethics instruction into accounting courses (Dellaportas 2017); and Adriaan Taylor (2013). More recently, ethics instruction has begun to be regarded as a necessary part of the socialization of accounting students into the profession (see, for example, Clikeman and Henning 2000).

There are a number of studies aimed at finding out whether accountants are ethical and whether they view their discipline as ethical. Based on some research findings, accountants were found to have less ethical awareness than expected and did not view accounting as an ethical discipline.

4.0 SOLUTION TO THE ISSUES:

In the light of the scandals and unethical behaviors of accountants what can be done to solve this problem? the solution is Islam, some ethical notions presumed a wider and more holistic significance to the accountant. In terms of responsibility, the accountant in Islam is not merely responsible to human superiors, the management/client or shareholders. He/ She is a servant and trustee of God in all situations, and is simultaneously responsible to God, the Owner of his very self and the resources he is utilizing and managing. To forget or to neglect this fundamental aspect of this responsibility is tantamount to a betrayal of divine trust with all the attending consequences in this world and in the next (Bhatti et al. 2016). The accountant in Islam is not only required to maintain a good relationship with superiors, clients and the management but he is also required to maintain, improve and strengthen his relationship with his Master by fulfilling his religious obligations. Islam is the religion that its followers believed came from the creator of the world, it's a religion that is term as a way of life. Islam has a fundamental ethical principle which if adapted in accounting could serve as solution to the ethical problem facing the profession at the moment. In Islam, ethics governs all aspects of life. Islam has its own concept of ethics that are derived from the Holy Qur'an and Sunnah. Islam provides the ideological foundation for a variety of personal attributes that promote economic development (Salahudin et al. 2016). Under Sharia led financial systems, more transparency, more disclosure and openness is required to ensure distributive justice. According to Rahim and Rahman (2003) in their paper seeks to address the importance of ethics in accounting education and evaluates the development of literature in this area. The paper argues that the direction should be on religious ethical development and values in developing accounting ethics rather than just focusing on the secular aspect of ethics and professional code of

conduct. The paper suggests that the Islamic worldview and ethics perspective can provide some insights into the process of developing a more humanized and ethical accountant.

5.0 CONCLUSION AND RECOMMENDATIONS

The realization that having a code of ethical conduct is necessary but may not be sufficient has prompted many to suggest that ethics need to be systematically incorporated into the accounting curriculum both at the tertiary level as well as in the professional education. However, there are a number of approaches that had been identified and can be adopted in teaching ethics in the accounting curriculum. For example, identified at least three models for integrating ethics into the accounting curriculum: devote half a semester of the Introduction to Business course to general business ethics; integrate ethics into each and every accounting course throughout the curriculum; and, develop a capstone course at the senior level that deals with the complex issues of business, social responsibility and professional responsibility.

This paper suggests an inclusion of Islamic accounting ethics as a program to teach ethics in the accounting curriculum. The course should also aim to make students aware of emerging issues facing the accounting profession and accountants. The AAOIFI's code of professional conduct can be used as a material to explain and expose students to the attributes of ethical awareness and principles from an Islamic perspective. However, the practical usefulness of the AAOIFI's code will be limited to the explanation of ethical principles such as trustworthiness and the like. Also ethics should not be treated as just another subject that students learn about. Islamic ethics is of no exception and it should be taught as a subject where students can relate to comprehensive ethical dilemmas that they have encountered in the accounting curriculum as well as to potential ethical dilemmas that they might be facing when they join the accounting profession. Ethics education should not involve the uncritical assimilation of professional codes of conduct. Students need to be exposed to critical debates and discussions on the code of professional conduct and not to treat ethical codes as just written guidelines. With these changes can be made in the ethical problems of accounting profession.

REFERENCES

- Adriaan Taylor. 2013. "Ethics Training for Accountants: Does It Add Up?" *Meditari Accountancy Research* 21(2):161–77.
- Beattie, V. 2000. "The Future of Corporate Reporting: A Review Article." *Irish Accounting Review* 7(1):1–36.
- Bhatti, Omar K., Uzma S. Aslam, Arif Hassan, and Mohamed Sulaiman. 2016. "Employee Motivation an Islamic Perspective." *Humanomics* 32(1):33–47.
- Clikeman, Paul M. and Steven L. Henning. 2000. "The Socialization of Undergraduate Accounting Students." *Issues in Accounting Education* 15(1):1–17.
- Dellaportas, Marzlin Marzuki Nava Subramaniam Barry J. Cooper Steven. 2017. "Asian Review of Accounting Article Information : Accounting Academics ' Teaching Self-Efficacy and Ethics Integration in Accounting Courses : A Malaysian Study Abstract." *Journal Accounting* 25(1):37–39.
- Graham, Carol M., Patrick Kelly, Dawn W. Massey, and Joan Van Hise. 2013. "One Size Does Not Fit All-Different Strategies for Teaching Accounting Ethics." *Research on Professional Responsibility and Ethics in Accounting* 17:139–57.
- Jaijairam, Paul. 2017. "Ethics in Accounting." (November).
- Kamla, Rania, Sonja Gallhofer, and Jim Haslam. 2006. "Islam, Nature and Accounting: Islamic Principles and the Notion of Accounting for the Environment." *Accounting Forum* 30(3):245–65.
- Mahdavikhou, Mahdi and Mohsen Khotanlou. 2012. "New Approach to Teaching of Ethics in Accounting 'Introducing Islamic Ethics into Accounting Education.'" *Procedia - Social and Behavioral Sciences* 46:1318–22.
- Rahim, Abdul and Abdul Rahman. 2003. "ETHICS IN ACCOUNTING EDUCATION : CONTRIBUTION OF THE ISLAMIC PRINCIPLE OF MA'LAH." 1(1):1–18.
- Salahudin, Shahrul Nizam bin, Siti Sarah binti Baharuddin, Muhammad Safizal Abdullah, and Abdullah Osman. 2016. "The Effect of Islamic Work Ethics on Organizational Commitment." *Procedia Economics and Finance* 35(August):582–90.
- Yarahmadi, Hossein and Email Hoyaryahoom. 2015. "Ethics in Accounting." 5(1):356–60.

SHARIAH INDICATORS OF SHARIA WEDDING ORGANIZER

Aisyah As Salafiyah, Muhammad Yusuf Ibrahim & Arip Rahman

Tazkia Islamic University College,

Abstract

The study is aim to seek, compile, and propose an index to measure the shariah indicators of wedding organizer. The study was used a multi-stages process of methodology, that is a literature review method and descriptive analysis. A literature review is used to compile a basic theory of wedding organizer sharia index which will be reviewed from a religious and scientific resources. Then, it will be elaborated by a descriptive analysis. The findings is, there are sixteen indexes to measure a shariahness of wedding organizer, that is (1) no seclusion, (2) no tradition that replaces sharia, (3) no pre-wedding, (4) make-up artist has the same gender as the bridegroom and keep the prayer time, (5) no standing party, (6) modest clothes (according to sharia), (7) in collaboration with halal catering, (8) no excessive make-up (*tabarruj*), (9) using an Islamic bank account, providing package options, (10) contract according to sharia, (11) no music, (12) no alcohol, (13) only accept legal, and (14) unwed pregnancy.

Keywords: Shariah Index, Maqashid Shariah, Wedding Organizer, Halal Industry

1.0 INTRODUCTION

1.1 Background

Halal lifestyle has become a trend that was spread around the world, whether in Muslim or non-Muslim country (Mohd Nawawi, et al., 2019). It was developed in all sectors, from food, cosmetic, travel to wedding organizer. That is caused by the increase of consumer interest in halal product. In a Muslim country, the awareness of halal becomes higher. Not only from believe side, but the halal of a product has been developed legally with a certain standardization (Abu-Hussin, et al., 2016). Furthermore, the trend is also progressed in a non-Muslim countries (Wilson, 2012).

Based on State of the Global Economic Report (2018). Malaysia has the higher halal indicator score than the other country, followed by United Arab Emirates, Bahrain and Saudi Arabia. Whilst, Singapore as non-Muslim country occupies an eleventh position as the halal country in the world. Overtake Indonesia as a biggest Muslim population country which is in tenth position (Agustina, et al., 2019).

Aside from Singapore, the halal lifestyle also blooming in Thailand. Moreover, the production of halal product of the country competes Malaysia. And Thailand has become the one of the top five halal producer country in Asia. It was recognized by Malaysia, Pakistan, Brunei Darussalam, Japan, Kuwait and Cambodia as a companion (Abdul Rahman, et al., 2013; Abdul, 2014). The conditions illustrate the increase of halal lifestyle interest in the world. herefore, the standardization or the indicators to measure the halal scientifically is needed. So as there is no fraud in claiming the halal status. So far, there is a lot of proposal about halal indicators of food and tourism, such as in Samori, et al., (2014), Battour & Ismail (2015), Nurrachmi (2017), Mastercard-Crescentrating (2018), Asnawi, et al., (2018), etc. But specifically, an index to measure the shariahness of wedding organizer still doesn't exist. While, the marriage is an obligation for a human especially a Muslim. As an industry which has a considerable potency, wedding organizer has been multiply. And not a few which claim itself to be sharia wedding organizer. Even though, the shariahness of those wedding organizer doesn't proven. Thus, to accomplish it, an index to measure the shariahness of wedding organizer is needed. So, there is no arbitrary claim on sharia status of wedding organizer.

1.2 Objectives

Regarding to the background, it is concluded that an objectives of this research are as follows;

- To describe and elaborate about sharia wedding organizer.
- To seek, compile, and propose an index to measure the sharia indicators of wedding organizer.

2.0 LITERATURE REVIEW

2.1 About Wedding Organizer

Wedding Organizer is a professional management activity that initiates activities in the world of marriage and makes it a conceptual and organized event. Like helping to find a wedding reception venue, entertainment at a wedding, decorating, catering, managing fashion vendors and photography vendors. The purpose of a Wedding Organizer is to make the customer calmer because he has an experienced team of partners to be invited to discussion, be asked for advice, and input. (Belinda, et al., 2018). The duties of a Wedding Organizer at a wedding are as follows:

- Planning the event, helping the event rundown.
- Doing budget planning.
- Accompany and arrange the event from the application program to the reception.
- Vendor planning and selection such as buildings, catering, decoration, bridal make-up and clothing, make-up and family clothing, invitations, documentation, photography, videos, souvenirs, performers, live music, traditional ceremonies, and so on.
- Oversee the running of the event and vendor readiness to support the running of the event (Directing, Monitoring, time-keeping, and check-listing).

Yonatan (2020) stated, in Indonesia, the birth of the Wedding Organizer and similar business entities is proof that marriage is a large-scale business field. The important role of the Wedding Organizer is like a hierarchical sequence.

2.2 About Wedding Organizer

Several studies related to the Wedding Organizer have been carried out, including the article written by Yuliani & Kosasi (2015), they found that the concept is the most important criterion in the decision making of a Wedding Organizer choice that is equal to 51%, continued with a 25% budget, 15% professionalism, and 9% reputation. Through this paper, Yuliani and Kosasi created a decision support system for choosing Wedding Organizer with the aim to help the bride and groom who will get married choose the right Wedding Organizer according to the needs and budget of the wedding provided.

In addition, Sugiono & Astika (2018) in their article stated that Wedding Organizer has now developed into an industry that is quite attractive because Indonesia is facing demographic bonuses where more productive numbers compared to unproductive ones. An increasingly modern era requires people to be busiest working, especially in urban communities, so the existence of a Wedding Organizer is a solution for couples who work in preparing for their wedding.

Followed by Merina (2019), she states that the implementation of marriage today is still not in accordance with sharia, such as the concept of standing parties, photo pre-wedding, excessive makeup, and clothing that does not cover genitals. So, departing from this phenomenon, there emerged a business in the world of marriage (Wedding Organizer) that carries a wedding party by an Islamic concept. The results is the interest of Islamic wedding party is at a moderate level where social media and subjective norms have a significant positive effect on the interest of wedding party. with the concept of sharia.

2.3 Maqashid Sharia

Syofyan (2014) explained, etymologically the sharia maqashid consists of two words, namely maqashid and sharia. maqashid is the plural form of *maqshud* which means intent or purpose. The sharia means the road to water, or can be said with the road to the source of life.

The concept of sharia maqashid actually started from the time of Al-Juwani which was famous for Imam Haramain and by Imam Al-Ghazali then was compiled systematically by *ushul fiqh* expert in Maliki's school from Granada (Spain), Al-Shatibi (2012). The concept was written in his famous book, *al-muwafaqat fi usul al ahkam* (the Reconciliation of the Fundamentals of Islamic Law), especially in chapter II, which he called the book *al-maqashid*.

According to as-Syatibi, basically sharia is established to realize the benefit of the servant (*mashalih al-ibad*) both the world and the hereafter. This benefit is the sharia maqashid and is divided into three categories, namely *dharuriyyat* (primary rights), *hajiyyat* (secondary rights) and *tahsiniyyat* (supplementary rights).

Dharuriyyat is maintaining the needs that are essential for human life. There are five basic needs, namely: religion (*al-din*), soul (*al-nafs*), lineage (*an-nasl*), wealth (*al-mal*) and intellect (*al-aql*). While *hajiyyat* is a need that is not essential, but a need that can prevent people from the difficulties of their lives. Not maintained this need does not threaten the five basic human needs. And *tahsiniyyat* is a necessity that supports the improvement of human dignity in society and before his Lord in accordance with obedience.

2.4 Sharia Index for Industrial Practice

Islamic Maqashid index is a measurement model of performance based on sharia objectives (Maqashid syariah). The maqashid al-shariah index is an index based on three visions, namely individual education (*ta'dib al-fard*), enforcement of justice (*iqamah al-adl*) and encouraging welfare (*jalb al-maslahah*) (Zahrah, 1958).

Rusydia & Firmansyah (2018) stated that the maqashid sharia index is one aspect in measuring that it can be said to be shariah compliant if it is in accordance with the shariah maqashid and through several stages. To produce Islamic maqashid index there are 3 (three) stages, namely:

- Determine the Performance Ratio

The first step that must be done is to determine the performance ratio that will be used based on data availability.

- Determine the Performance Ratio

The next stage is to perform multiplication operations between dimensions and performance ratios with each weight. Mathematically can be explained in the following models:

- Educating Individuals
- Enforce Justice
- Producing Benefit

- Calculating the Maqashid index

The complete understanding of maqashid index is taken from the noble value of Islam (maqashid syariah) which is understood as the ultimate goal of sharia which promotes the values of well-being and benefits (*jalb al masalih*) also relieving suffering (*dar al-mafasid*).

The maqashid index of sharia is understood as the ultimate goal of sharia which leads to the values of well-being and benefits and relieving suffering. The Islamic maqashid Index was developed by Abu Zahrah into 3 Sharia objectives, namely:

- a. *Tahdhib al-fard* (Individual Education)
- b. *Iqamah al-'adl* (Embodiment of Justice)
- c. *Jalb al-maslahah* (Community Welfare)

3. METHODOLOGY

3.1 Literature Review Method

A literature review was a method which used to analyze critically or gathering a summaries with a relevant resources (Cronin, et al., 2008). Where the main purpose is updating a literature or establish a research basics to be used in further research (Ramdhani, et al., 2014). At this research, the using of this method is aimed to compile a basic theory of wedding organizer sharia index. The compilation will be reviewed from a religious and scientific resources. It is because the research is related to the religion existence. So, the using of religion sources is required at this compilation. Then, the compilation will be strengthened by a scientific literature.

3.2 Descriptive Analysis

Regarding to Loeb, et al. (2017), descriptives analysis a fundamental component of observation, question identification, hypotheses encogitation and examination to generate a new question, hypotheses or observation. Descriptive analysis is used for various purposes, such as describing the trend, create the new measure of a phenomenon, or even only to describe a samples of a study.

Whilst, at this research, the use of this method is aim to create the new measure of a phenomenon. That is, after compiling an index with literature review method. The authors will elaborate the explanation of the index or indicators in a substantive forms implemented in Ibrahim, et al. (2019).

4. DISCUSSION

The framework of the study that describes the performance measurement of sharia-based wedding organizers based on maqashid shariah theory. maqashid shariah theory used is the concept of maqashid shariah compiled by the author based on references from various sources. Based on this index, the performance measurement of wedding organizer is measured in terms of maqashid shariah or its sharia objectives which are translated into five goals and sixteen indicators.

The first goal is to protecting the religion divided into five indicators. Then the second goal, which is protecting the life or soul, is divided into four indicators. In the third goal, protecting the wealth divided into three indicators. In the fourth goal, protecting the intellect divided into two indicators. The fifth goal, which is to protecting the lineage, is divided into two indicators. The wedding organizer index table in accordance with sharia provisions can be seen in table 1 below.

Table 1. Wedding organizer index

No	Goals	Indicator	Source
1	Protection of Religion (Al-Din)	No jumble between men and women (seclusion)	QS. Al-Ahzab, 33: 53
		No custom or tradition that replaces sharia	Shahih Bukhari, 7: 6774
		No Pre-Wedding	QS. Al-Isra', 17: 32
		Make-up artist has the same gender as the bridegroom	Shahih Bukhari, 5: 4516
		Keep the prayer time	QS. An-Nisa, 4: 103
2	Protection of Life or Soul (An-Nafs)	No Standing Party	Shahih Muslim no. 2024
		Modest clothes (according to sharia)	QS. Al-Ahzab, 33: 59
		In collaboration with halal catering	QS. An Nahl, 16: 114
		No excessive make-up (<i>tabarruj</i>)	QS. Al-Ahzab, 33: 33
3	Protection of Wealth (Al-maal)	Using an Islamic bank account	Qs. Ali Imran, 3: 130
		Providing package options	QS. Al Isra, 17: 29-30
		Muamalah contract according to sharia	QS. An Nisa, 4: 29
4	Protection of Intellect (Al-'aql)	No music	QS. Luqman, 31: 6-7 Shahih Bukhari, 4: 3638
		No alcohol	QS. Al-Baqarah, 2: 219 QS. Al-Maidah, 5: 90-91
5.	Protection of Lineage (An-nasl)	Only accept legal and official marriages.	QS. Al Isra, 17: 32
		Not accepting MBA partners (Married by Accident)	QS. An Nur, 24: 3

Roles and tasks performed by sharia wedding organizers have been endeavored to comply with Islamic regulations, but there are still differences in activities and facilities with different Islamic principles between one wedding organizer and other wedding organizers, this is because there is no index that comprehensively discusses any indicators which must be fulfilled by a sharia wedding organizer. Therefore, the following is a classification of the index of sharia wedding organizer that has been prepared based on sharia maqashid and has a strong foundation from the Quran and Sunnah.

4.1 Protection of Religion

No Seclusion

In terms of danger, of course seclusion has a great treatment that is to damage one's heart so that it is compelled to think about adultery and even do it. The danger of seclusion starts from the sight of the eye and then moves into a person's heart and heart is very weak, while his lust always invites evil. Therefore, in a wedding for men and women should be placed in a separate place accompanied by a veil as a barrier so as not to cause *mudharat*. As mentioned in QS. Al-Ahzab, 33: 53.

يَا أَيُّهَا الَّذِينَ آمَنُوا لَا تَدْخُلُوا بُيُوتَ النَّبِيِّ إِلَّا أَنْ يُؤْذَنَ لَكُمْ إِلَى طَعَامٍ غَيْرٍ نَاظِرِينَ إِنَاهُ وَلَكِنْ إِذَا دُعِيتُمْ فَادْخُلُوا فَإِذَا طَعِمْتُمْ فَانْتَسِرُوا وَلَا مَسْتَأْذِينَ لِحَدِيثٍ إِنَّ ذَلِكُمْ كَانَ يُؤْذِي النَّبِيَّ فَيَسْتَحْيِي مِنْكُمْ وَاللَّهُ لَا يَسْتَحْيِي مِنَ الْحَقِّ وَإِذَا سَأَلْتُمُوهُنَّ مَتَاعًا فَاسْأَلُوهُنَّ مِنْ وَرَاءِ حِجَابٍ ذَلِكُمْ أَطْهَرُ لِقَوْلِكُمْ وَقُولِهِنَّ وَمَا كَانَ لَكُمْ أَنْ تُؤْذُوا رَسُولَ اللَّهِ وَلَا أَنْ تُنكِحُوا أَرْوَاحَهُنَّ مِنْ بَعْدِهِ أَبَدًا إِنَّ ذَلِكُمْ كَانَ عِنْدَ اللَّهِ عَظِيمًا

"O you who have believed, do not enter the houses of the Prophet except when you are permitted for a meal, without awaiting its readiness. But when you are invited, then enter; and when you have eaten, disperse without seeking to remain for conversation. Indeed, that [behaviour] was troubling the Prophet, and he is shy of [dismissing] you. But Allah is not shy of the truth. And when you ask [his wives] for something, ask them from

behind a partition. That is purer for your hearts and their hearts. And it is not [conceivable or lawful] for you to harm the Messenger of Allah or to marry his wives after him, ever. Indeed, that would be in the sight of Allah an enormity”.

There is no custom or tradition that violates sharia

Islamic teachings and regulations must be higher than everything. Any events, ceremonies, and customs that are contrary to Islam must be abandoned and eliminated. Some Muslims in the way of marriage always elevate and flatter local customs, so that the Sunnah of the Prophet Saw is right and authentic they have been turned off and extinguished. Whereas the Sunnah of the Prophet Saw is the light in this religion.

لَا تَعُومُ السَّاعَةُ حَتَّى تَأْخُذَ أُمَّتِي بِأَخْذِ الْقُرُونِ قَبْلَهَا، تَبِيرًا بِتَبِيرٍ وَبِزَاعًا بِبِزَاعٍ. قِيلَ يَا رَسُولَ اللَّهِ كَفَارِسَ وَالرُّومِ. فَقَالَ وَمَنْ النَّاسُ إِلَّا أَوْلَادُكَ

"Doomsday will not occur until my umat take the path of the previous generation inch by inch, one by one. Then someone asked the Messenger of Allah SWT., Do they need it like Persia and Rome? He replied, who else then?" (Shahih Bukhari, 7: 6774).

So in a Sharia Wedding Organizer does not accept customs in a marriage that violates Sharia such as customary dress that makes the bride and her companions or the bridegroom to show genitalia, show off hair, shoulders and other body parts to the audience, or ceremonies traditional ceremonies that are clearly shirk like the ceremony of stepping on an egg which is felt to bring blessing. Thus, the Sharia Wedding Organizer does not accept the existence of concepts, regulations, teachings, and procedures other than those in accordance with Islamic teachings.

No Pre-Wedding

Islam forbids twos between couples who are not yet halal. The pre-wedding photo in question is an intimate photo of the prospective husband and future wife that was carried out before the marriage contract. Pre-wedding photos are forbidden because when taking pictures, they don't have any ties. That is not justified in Islamic law. In a pre-wedding, for the bride and groom is forbidden because in making the photo is done accompanied by the existence of seclusion. While the work of a pre wedding photographer is also forbidden because it is considered to show a willingness to disobey. Allah explains in His Word QS. Al-Isra, 17: 32

وَلَا تَقْرُبُوا الزَّوْجَىٰ إِنَّهُ كَانَ فَاحِشَةً وَسَاءَ سَبِيلًا

“And do not approach unlawful sexual intercourse. Indeed, it is ever an immorality and is evil as a way”.

In this verse Allah forbids His servant to commit adultery and approach him. Likewise, it is not permissible to attack the things that are approaching and encouraging adultery, including here are the twos when pre-wedding photos. Thus, it should be in a Sharia Wedding Organizer to negate a pre-wedding so as not to fall into disobedience.

Make-up artist has the same gender as the bridegroom

It is forbidden for a man to touch a woman who is not his mahram. Vice versa, a woman should not touch a man who is not his mahram.

عَنْ ابْنِ عَبَّاسٍ رَضِيَ اللَّهُ عَنْهُمَا قَالَ تَعَدَّتْ الصَّلَاةُ يَوْمَ الْبَطْرِ مَعَ رَسُولِ اللَّهِ صَلَّى اللَّهُ عَلَيْهِ وَسَلَّمَ وَأَبِي بَكْرٍ وَعُمَرُ وَعُثْمَانُ فَكَلَّمَهُمْ بِمَسَلِّيهَا قَالَ الْخَلِيفَةُ ثُمَّ يَخْتَلِبُ بِيَدِ فَذَلَّ نَبِيُّ اللَّهِ صَلَّى اللَّهُ عَلَيْهِ وَسَلَّمَ فَكَانَتْ أَنْظَرُ إِلَيْهِ جِئِينَ الرَّجَالَ بِيَدِهِ ثُمَّ أَقْبَلَ يَسْعُهُمْ حَتَّى أَتَى النِّسَاءَ مَعَ بِلَالٍ فَقَالَ يَا أَيُّهَا النَّبِيُّ إِذَا جَاءَكَ الْمُؤْمِنَاتُ يَتَابَعَنَّكَ عَلَى أَنْ لَا يُسْرَكَنَّ بِاللَّهِ شَيْئًا وَلَا يَسْرَقَنَّ وَلَا يَزْنَيْنَّ وَلَا يَقْتُلَنَّ أَوْلَادَهُنَّ وَلَا يَكْفَيْنَّ بِيَهْتَانٍ يَفْتَرِيهِنَّ بَيْنَ آبَائِيهِنَّ وَأَرْجُلِيهِنَّ حَتَّى قَرَعَ مِنْ آيَةِ كَلِمَاتٍ قَالَتْ أَمَّا ذَلِكَ فَقَالَتْ امْرَأَةٌ وَاجِدَةٌ لَمْ يُجِبْهُ غَيْرُهَا نَعَمْ يَا رَسُولَ اللَّهِ لَا يَدْرِي الْكُفْرُ مَنْ هِيَ قَالَ فَصَدَّقَنِّي وَبَسَطَ بِلَالٌ تَوْبَهُ فَجَعَلَنِّي يَلْبَسُ النَّعْجَ وَالْحَوَاتِيمَ فِي تَوْبِ بِلَالٍ

“Ibn Abbas ra. said; I once participated in the 'Eid Al-Fithri Prayers with the Prophet saw, Abu Bakr, Umar and Utsman, then all prayed before the khutbah. And after prayer, then they deliver the sermon. When the Prophet saw came down, then I saw when he ordered with his hands that the men sit. And after that, he walked accompanied Bilal past them until he reached the place where the women are. Then he read: “O Prophet, if the women of faith come to you to pledge to obey that they will not associate anything with God, do not steal, do not commit adultery, and will not kill their children, and will not do lies ...” (QS. Al-Mumtahanah 12). Until he finished reading the whole verse. After that he said: "You are all above that promise." Then one of the women answered, Yes, O

Messenger of Allah. While the others are silent. Al Hasan does not know who this woman is. Eventually the women gave alms, while Bilal spread his clothes, while they threw their bracelets and rings into Bilal's clothes (Shahih Bukhari, 5: 4516).

Based on it, Touches of the opposite sex who are not permitted by Islamic teachings are not justified. Therefore, the Sharia Wedding Organizer must provide the same makeup artist as the women for the bride and the man for the groom.

Keep the prayer time

فَإِذَا فَحِثْتُمْ الصَّلَاةَ فَادْكُرُوا اللَّهَ قِيَامًا وَقُعُودًا وَعَلَىٰ جُنُوبِكُمْ ۚ فَإِذَا اطْمَأْنَنْتُمْ فَأَقِيمُوا الصَّلَاةَ ۗ إِنَّ الصَّلَاةَ كَانَتْ عَلَى الْمُؤْمِنِينَ كِتَابًا مَوْقُوتًا

"And when you have completed the prayer, remember Allah standing, sitting, or [lying] on your sides. But when you become secure, re-establish [regular] prayer. Indeed, prayer has been decreed upon the believers a decree of specified times." (QS. An-Nisa, 4: 103)

Included in the marriage ceremony are the bride and groom neglecting the five daily obligatory pray. It is unfortunate, most Muslims are neglected in the obligatory prayer when they do a wedding reception. The number of guests, make-up that sticks to the face or wedding dress worn should not prevent to pray at the beginning of time. Sharia Wedding Organizer will provide a reminder time and invite the bride and groom, family and invited guests to pray first and then continue the wedding.

4.2 Protection of Life or Soul

No Standing Party

Standing party is eating or drinking while standing which is usually found in a wedding. Eating and drinking while standing is prohibited in Islam.

أَنَّ النَّبِيَّ -صَلَّى اللَّهُ عَلَيْهِ وَسَلَّمَ- زَجَرَ عَنِ الشَّرْبِ قَائِمًا

The Prophet Saw really forbade from drinking while standing (Shahih Muslim, [37] Book of Drinks: 3771)

Sharia Wedding Organizer will provide a seat in accordance with the number of invited guests who have been predetermined, but to ensure or estimate the number of invited guests who are present the bride and groom should choose to make the Sharia Wedding Organizer provide more seats in case the extra invited guests avoid guests invitation to eat and drink while standing.

Modest clothes (according to shariah)

In the prospective bride must wear Islamic clothes that cover the shape of the curves of her body, also veil and complete with and feet. This is the command of Allah in his word QS. Al-Ahzab, 33: 59.

يَا أَيُّهَا النَّبِيُّ قُلْ لَأَزُوجِكُمْ وَبَنَاتِكُمْ وَنِسَاءَ الْمُؤْمِنِينَ يُبْدِينَ عُلُوقَهُنَّ مِنْ جَلْبَابِهِنَّ ۚ ذَلِكَ أَدْنَىٰ أَنْ يُعْرَفْنَ فَلَا يُؤْذَيْنَ ۗ وَكَانَ اللَّهُ غَفُورًا رَحِيمًا

"O Prophet, tell your wives and your daughters and the women of the believers to bring down over themselves [part] of their outer garments. That is more suitable that they will be known and not be abused. And ever is Allah Forgiving and Merciful."

In collaboration with halal catering

Sharia Wedding Organizer must ensure that the catering used is halal catering, because this is very important. As Allah commands His people to eat halal food again both in QS. An-Nahl, 16: 114

كُلُوا مِمَّا رَزَقَكُمُ اللَّهُ حَلَالًا طَيِّبًا وَاشْكُرُوا ۚ تَعْمَتَ اللَّهُ إِنْ كُنْتُمْ إِتَاءَهُ تَشْكُرُونَ

"Then eat of what Allah has provided for you [which is] lawful and good. And be grateful for the favor of Allah, if it is [indeed] Him that you worship".

No excessive make-up (*tabarruj*)

In addition to providing similar makeup, ornate procedures must be in accordance with the guidance of shar'i, do not resemble infidel women, do not change God's creation and do not resemble men. As explained in the word of God in the QS. Al-Ahzab, 33:

وَقَرْنَ فِي بُيُوتِكُنَّ وَلَا تَبَرَّجْنَ تَبَرُّجَ الْجَاهِلِيَّةِ الْأُولَى ۚ وَأَقِمْنَ الصَّلَاةَ وَآتِينَ الزَّكَاةَ وَأَطِعْنَ اللَّهَ وَرَسُولَهُ ۚ إِنَّمَا يُرِيدُ اللَّهُ لِيُذْهِبَ عَنْكُمُ الرِّجْسَ أَهْلَ الْبَيْتِ وَيُطَهِّرَكُمْ تَطْهِيرًا

“And abide in your houses and do not display yourselves as [was] the display of the former times of ignorance. And establish prayer and give zakat and obey Allah and His Messenger. Allah intends only to remove from you the impurity [of sin], O people of the [Prophet's] household, and to purify you with [extensive] purification”.

As for wearing false eyelashes are included fraud and including changing God's creation. Just like pulling or shaving the eyebrows to tidy up is included in the hadith ban on shaving the eyebrows in general. Including tabamuj wearing hijab or clothing that depicts (shape) the body even though the fabric is not thin, such as the hijab or tight clothing worn by many women today, so clearly illustrated their posture and limbs.

4.3 Protection of Wealth

Using an Islamic bank account

The purpose of transactions carried out using Islamic accounts is to ensure that the assets received originate from halal assets. Although it does not guarantee certainty, but it becomes an endeavor to be free from conventional banks, which is certainly the torment that occurs therein. As Allah has forbidden in QS. Al-Imran, 3: 130.

يَا أَيُّهَا الَّذِينَ آمَنُوا لَا تَأْكُلُوا الرِّبَا أَضْعَافًا مُضَاعَفَةً وَاتَّقُوا اللَّهَ لَعَلَّكُمْ تُفْلِحُونَ

“O you who have believed, do not consume usury, doubled and multiplied, but fear Allah that you may be successful.”

Providing package options

The purpose of providing package options here is to avoid burdensome for prospective customers who want to use Sharia Wedding Organizer at a cost that is not burdensome with the various package options available, so Sharia Wedding Organizer can not only be used by capable people.

وَلَا تَجْعَلْ يَدَكَ مَغْلُولَةً إِلَىٰ عُنُقِكَ وَلَا تَبْسُطْهَا كُلَّ الْبَسْطِ فَتَقْعُدَ مَلُومًا مَّحْسُورًا - إِن رَّبُّكَ يُنْطِقُ الرُّزُقَ لِمَن يَشَاءُ وَيَقْدِرُ ۗ إِنَّهُ كَانَ بِجَوَاهِرِهِ خَبِيرًا
بصيرًا

“And do not make your hand [as] chained to your neck or extend it completely and [thereby] become blamed and insolvent. Indeed, your Lord extends provision for whom He wills and restricts [it]. Indeed He is ever, concerning His servants, Acquanted and Seeing.” (QS. Al-Isra, 17: 29-30)

Muamalat contract according to sharia

Using a contract that is clearly in accordance with sharia is one form of efforts to achieve halal fortune. Allah mention in QS. An-Nisa, 4: 29.

يَا أَيُّهَا الَّذِينَ آمَنُوا لَا تَأْكُلُوا أَمْوَالَكُمْ بَيْنَكُمْ بِالْبُطْلِ إِلَّا أَن تَكُونَ تِجَارَةً عَن تَرَاضٍ مِّنْكُمْ ۚ وَلَا تَقْتُلُوا أَنْفُسَكُمْ ۚ إِنَّ اللَّهَ كَانَ بِكُمْ رَحِيمًا

“O you who have believed, do not consume one another's wealth unjustly but only [in lawful] business by mutual consent. And do not kill yourselves [or one another]. Indeed, Allah is to you ever Merciful.”

Every transaction made by several parties who are directly bound to the Sharia Wedding Organizer must use a clear agreement in accordance with the Sharia, so that no party is wronged with each other, in order to achieve a blessed business and get the blessing of Allah Swt.

4.4 Protection of Intellect

No music

Another crime in marriage is the presence of music, whether in the form of musical instruments, songs or songs or entertainment stage. Music in the Islamic view is haram, because in fact songs and songs cause hypocrisy in the heart and make sense corrupted. Allah Swt mentioned in QS.Luqman, 31: 6-7.

وَمِنَ النَّاسِ مَن يَشْتَرِي لَهْوَ الْحَدِيثِ لِيُضِلَّ عَن سَبِيلِ اللَّهِ بِخَيْرٍ عِلْمٍ وَيَتَّخِذَهَا هُزُوًا ۗ أُولَٰئِكَ لَهُمْ عَذَابٌ مُّهِينٌ

“And of the people is he who buys the amusement of speech to mislead [others] from the way of Allah without knowledge and who takes it in ridicule. Those will have a humiliating punishment”.

جاء النبي صلى الله عليه وسلم فتدخل حين نبي علي فجلس على فراشي كمنجلىك مني فجلست جواريات لنا يحترين بالدف وتنين من قبل من ابالي
يوم بدر إذ قالت إحداهن وبينا نبي يعلم ما في غد فقال دعي هذه وقولي بالذي كنت تقولين

"One time, the Prophet saw and entered when I was married. Then he sat on my bed, as you sat from me. Then the female slaves hit the tambourine and remembered the privileges of soldiers who died during the Battle of Badr. Then one of them also said: And in our midst there is a Prophet, who knows what will happen tomorrow. So he said: Leave this phrase, and say what you want to say" (Shahih Bukhari, 4: 3638).

No Alcohol

Keep your mind by not providing drinks that can be intoxicating in a wedding. In addition to the effects it can bring to mind, it is clear that the forbidden Allah has conveyed in QS. Al-Maidah, 5: 91.

إنما يريد الشيطان أن يوقع بينكم العداوة والبغضاء في الخمر والميسر ويصدكم عن ذكر الله وعن الصلاة فهل أنتم منتهون

"Satan only wants to cause between you animosity and hatred through intoxicants and gambling and to avert you from the remembrance of Allah and from prayer. So will you not desist?"

4.5 Protection of Lineage

Only accept legal and official marriages

ولا تقربوا الزنى إنه كان فحشاء ومناء شبيها

"And do not approach unlawful sexual intercourse. Indeed, it is ever an immorality and is evil as a way." (Surat Al-Isra, 17: 32)

Sharia Wedding Organizer will ensure that prospective customers who will use their services are free from unauthorized marriages or adultery. By asking that prospective customers show official proof or marriage certificate. Thus, we can be sure that marriage originates from a legal marriage.

Not accepting MBA partners (Married by Accident)

Sharia Wedding Organizer does not accept couples who come from marriages that are carried out due to pregnancy out of wedlock, or what is currently known as married by accident. Sharia Wedding Organizer will ensure that every prospect comes from a marriage blessed by Allah Swt as mentioned in QS. An-Nur, 24: 3

الزاني لا يتكح إلا زانية أو مشركه والزانية لا يتكحها إلا زان أو مشرك وحرم ذلك على المؤمنين

"The fornicator does not marry except a [female] fornicator or polytheist, and none marries her except a fornicator or a polytheist, and that has been made unlawful to the believers."

5. CLOSING STATEMENT

5.1 Conclusion

The findings is, there are sixteen indexes that can be used to measure a shariahness of wedding organizer which based on five maqashid shariah indicators. And the result was (1) no seclusion, (2) no tradition that replaces sharia, (3) no pre-wedding, (4) make-up artist has the same gender as the bridegroom and keep the prayer time, (5) no standing party, (6) modest clothes (according to sharia), (7) in collaboration with halal catering, (8) no excessive make-up (*tabarruj*), (9) using an Islamic bank account, providing package options, (10) contract according to sharia, (11) no music, (12) no alcohol, (13) only accept legal, and (14) unwed pregnancy.

5.2 Implication

Each of indicators regard to Al-Quran and the Hadith. Means, it is accordance to Islamic law. And the indexes will be used to measure a sharianess of wedding organizer. So, it is recommended to wedding organizers to prove the shariahness the business based on this indicators. Because it can prove the shariah status of the wedding organizers. But, the study has limitations on the compilation of indices to measure the wedding organizer's willingness. So that, the further research is required to develop this research by different methods. Where, a further researchers can measure the shariahness of wedding organizers which claim a shariah status based on the indexes. It is required to ensure that, there is no fraud claim of this status. Besides it, the further research can strengthen the theory of an index by an opinion of the expert.

REFERENCES

- Al-Quran Al-Karim.- Waqf from King Abdullah bin Abdulaziz Al Saud. (2006). Madinah Al-Munawwarah.
- Al-Bukhari, M. bin I. (1981). Shahih Bukhari. Beirut. Darul Fikr.
- Al-Shatibi, I. I. M. (2012). The Reconciliation of the Fundamentals of Islamic Law: Vol. I. Reading. Garnet Publishing Limited.
- An-Naisaburi, M. bin A. H. (1991). Shahih Muslim. Beirut. Dar Kutub Ilmiyyah.
- Antonio, M. S., Sanrego, Y. D., & Taufiq, M. (2012). An Analysis of Islamic Banking Performance : Maqashid Index Implementation in Indonesia and Jordania. Journal of Islamic Finance, 176(813), 1–18. platform.almanhal.com/Details/Article/37299
- Belinda, I. I., Hanum, I., & Salayanti, S. (2018). Perancangan Bride Center di Bandung. E-Proceeding of Art & Design, 5(3), 3103–3110.
- Duvall, E., & Miller, B. (1985). Marriage and family development. Harper & Row. <http://agris.fao.org/agris-search/search.do?recordID=US201300387858>
- Fatimatuzahra, I. R. (2016). Analisis Kinerja Perbankan Syariah Indonesia Ditinjau Dari Maqashid Sharia : Pendekatan Maqashid Sharia Index. Universitas Islam Indonesia.
- Meri Merina, -. (2019). Pengaruh Media Sosial Dan Norma Subyektif Terhadap Minat Mahasiswa Pada Walimatul ‘Ursy Dengan Konsep Syariah : Studi pada Mahasiswa Fakultas Pendidikan Ekonomi dan Bisnis Universitas Pendidikan Indonesia Kampus UPI Bandung [Universitas Pendidikan Indonesia]. <http://repository.upi.edu>
- Mohammed, S., Lorenzen, K., Kerkhoven, R., van Breukelen, B., Vannini, A., Cramer, P., & Heck, A. J. R. (2008). Multiplexed proteomics mapping of yeast RNA polymerase II and III allows near-complete sequence coverage and reveals several novel phosphorylation sites. Analytical Chemistry, 80(10), 3584–3592. <https://doi.org/10.1021/ac7024283>
- Mutia, E., & Musfirah, N. (2017). Pendekatan Maqashid Shariah Index Sebagai Pengukuran Kinerja Perbankan Syariah Di Asia Tenggara. Jurnal Akuntansi Dan Keuangan Indonesia, 14(2), 181–201. <https://doi.org/10.21002/jaki.2017.10>
- Nisa, M., Amrulloh, M. R. A., & Rozaki, A. W. (2019). Aplikasi SHAWOO (Sharia Wedding Organizer Online): Upaya Inklusi Produk Layanan Halal Dengan Konsep Sharing Economy.
- Rusydia, A. S., & Firmansyah, I. (2018). Efficiency versus Maqashid Sharia Index: an Application on Indonesian Islamic Bank. Shirkah: Journal of Economics and Business, 2(2). <https://doi.org/10.22515/shirkah.v2i2.154>
- Sekaran, U., & Bougie, R. (2000). Research methods for business: A skill-building approach. John Wiley & Sons.
- Sugiono, R. A. (2018). Analisis Pengaruh Harga, Promosi Dan Citra Perusahaan Terhadap Keputusan Penggunaan Jasa Wedding Organizer (Studi Pada Griya Cantik Ozza wedding Organizer). UIN Raden Intan Lampung.
- Syofyan, A. (2014). Analisis kinerja bank syariah dengan metode indeks maqasid syariah di indonesia. Al Masraf: Jurnal Lembaga Keuangan Dan Perbankan, 2(2), 145–158.
- Yuliani, I. D. A. E., & Kosasi, S. (2015). Sistem Pendukung Keputusan Pemilihan Wedding Organizer. Eksplora Informatika, 5(1). <http://www.ejournal.stikom-bali.ac.id/index.php/0410362/article/view/590>

OPERATIONAL SPECIFIC FACTORS (OSF) THAT IMPACTED THE PERFORMANCE OF FAMILY TAKAFUL OPERATORS IN MALAYSIA

Zainordin Zinon Abidin^a, Noraziah Che Arshad^b & Nor Jannah Ismail^c

^{a,c} Commerce Department, Politeknik Muadzam Shah, Malaysia

^b Islamic Business School, Universiti Utara Malaysia, Malaysia

Abstract

Global Islamic finance industry consists of four main markets; banking, sukuk, takaful and Islamic funds. Among all the markets, takaful is provide significant element to the Islamic finance industry. The takaful performance is important indicator to evaluate the effectiveness of the industry and shows how the industry counters to the challenges and help their businesses survive. The purpose of this study is to analyse the performance of 11 family takaful operators in Malaysia for the period 2013 to 2018. There are five operational specific factors (OSF) tested in this study which are size, capital, premium growth, underwriting risk and expense ratio. This study use a panel data analysis to analyze the data obtained from family takaful operator's financial statements. The findings show that the performance of family takaful operators was affected by four types of OSFs which are size, capital, underwriting risk and expense ratio, while premium growth was found have no impact to the performance of family takaful operators. The capital which is having a greater impact from other OSFs on the performance of family takaful operators in Malaysia. From these results, it is recommended that the family takaful operators should control and manage properly their capital in order to increase companies' performance and stabilize their financial system.

Keywords: Performance, Family Takaful operators, operational specific factor.

1.0 INTRODUCTION

An important element in the financial services sector such as takaful and insurance industry is performance. It is important indicator to evaluate the effectiveness of the industry, how does the industry counter to the challenges and which companies are going to survive their businesses. In addition, the Malaysian financial system's landscape has experienced major structural changes through the era of globalisation with numerous liberalism measures popularized over the last century. Such conditions are likely to affect the insurance industry's performance. According to Mwangi and Iraya (2014), performance is an indicator of an institution's income, and profitability as proofed by the growth in the organization's share value. The performance is used to measure the efficiency of an assets used by entities to generating profits. It will give the indication of the management level in managing the assets. High level performance is important to company because would increase confident level of an investors to make investments that would generate the company's profit (Heikal, Khaddafi and Ummah 2014).

1.2 Overview of Family Takaful industry in Malaysia.

Takaful is an Islamic Insurance based on Islamic principles which accordance with Shariah rules. Sudan and Saudi Arabia was the pioneer of the takaful industry in the late year of 1970s (Abduh, Omar and Tarmizi, 2012). The takaful industry began in Malaysia in the early 1980s as a response to Muslims' needs to have an alternative to conventional insurance at that time. A committee has been set up by the Malaysian government to examine the possibility of forming an Islamic insurance company in Malaysia in 1982. As a result, Takaful Act was enacted in Malaysia in 1984 and Syarikat Takaful Malaysia Berhad became the first takaful operator in Malaysia in November 1984 (Lim, Idris & Carissa, 2010).

According to BNM (2019), presently, there are 11th family Takaful operators registered in Malaysia including AIA Public Takaful Berhad, Ammetlife Takaful Berhad, Great Eastern Takaful Berhad, Etiqa Family Takaful Berhad, Zurich Takaful Berhad, Syarikat Takaful Malaysia Keluarga Berhad and Takaful Ikhlas Family Berhad. Hong Leong MSIG Takaful, FWD Takaful Berhad (formerly known as HSBC Amanah Takaful), Prudential BSN Takaful Berhad, and Sun Life Malaysia Takaful Berhad (formerly known as MAA Takaful). In November 2002,

the Malaysian Takaful Association (MTA) is established under the Malaysian Societies Act of 1966 and their main functions as a supervise self-regulation entity to promote and protect the interests of Takaful operators industry in Malaysia.

In Malaysia, Takaful industry has been regulated under the Islamic Financial Services Act 2013 (IFSA 2013). This Act had replaced the previous law regulating the takaful namely Takaful Act 1984. An important change brought for takaful industry by enacted of IFSA was the split licenses of insurance and takaful entities for their life/family and general businesses in order to improve the administration of general and family business operations in Malaysia. According to Bank Negara Malaysia (BNM, 2019), the IFSA 2013 is an initiatives to streamline the laws governing the conduct and oversight of financial institutions in Malaysia to make sure that this laws tends to be significant and efficient in maintaining the performance of industry, encourage sustainable growth of industry and provide sufficient insured's protection (Thajudeen, 2015). The reason for the decoupling of Takaful industry specifically to push them into a new level of maturity, and at the same time, the takaful operators can participate in strategic alliances and partnerships to meet the higher capital requirements. Besides that, the takaful business can concentrate all the resources on improving performance of a specific line of business. It can also provide opportunity for new takaful industry players to be more competitive to their counterpart conventional insurance industry (Thajudeen, 2015).

Table 1.1: Profits of family takaful operators in Malaysia.

Year	2014	2015	2016	2017	2018
	(RM Millions)				
Family Takaful operators	2,116.0	1,671.5	2,009.6	2,526.5	2,171.6

Source: Financial Stability reports 2018,1

Table 1.1 shows the amount of excess income over outgo or profits of family takaful operators in Malaysia. It shows that the profit recorded by family takaful operators in 2014 was RM2,116 million and decreased to RM1,671.5 million in 2015, however, in 2016, profits rose back to 2,009.6 million and continued to increase to RM2,526.5 million during the year 2017. However, in 2018, it recorded a decrease to 2,171.6 million. It can be concluded that takaful industries shows a decline trend in profitability for 2018.

Behind the trend of increasing and decreasing of family takaful operator's performance, there are several factors that influence the result of this trend. Therefore, the operational specific factors that impacted the performance of the takaful in Malaysia needs to be analysed to investigate which factors that gave impact to performance of Family takaful operator in generating a profit especially after new Act of IFSA 2013 has been enacted as well as to investigate whether the enforcement of this new Act would give impact and improving the performance of takaful or not.

2.0 LITERATURE REVIEW

2.1 CAMEL framework model

Financial Soundness Indicators (FSI) is used for insurance industry are known as CAMELS. CAMELS are stands for Capital adequacy, Asset quality, Reinsurance, Adequacy of claims and actuarial, Management soundness, Earnings and profitability, Liquidity and Sensitivity to market risk. This framework was commonly used in insurance industry and has displayed an excellent outcome in the assessment of insurance industry's financial soundness. (Smajla, 2014).

This framework has been design in IMF-Background paper by Das, Davies and Podpiera, (2003) and the paper also proposes CAMELS framework as a set of crucial factors that to be used for monitor the insurance companies' financial soundness and the insurance industry itself.

Table 2.1: The variable used related to CARAMELS framework model.

Type of Financial Sound	CARAMEL Framework	Variable used in this study
Indicator (FSI)	Indicator	
Financial Performance	Capital Adequacy	Capital
	Asset Quality	Size
	Management Soundness	Underwriting risk Expense ratio
	Earnings /Profitability	Premium growth

2.2 Profitability

According to Abduh, Omar and Tarmizi (2012) there are various ways to evaluate the performance of Takaful operators. One of the most commonly used is to look at company profits. Generally, the performance of insurance industry can be estimated by measuring their profitability, which is an indicator of business' successful and it represent the financial performance (Mazviona, Dube, & Sakahuhwa, 2017).

Thus, this study will evaluate the performance of family Takaful operator and life insurance companies which is referring the profitability as a variable that attributable to the financial performance. Profitability is the key goal of financial management which is to optimise the interests of the owners. Without profitability the firm may not endure in the long term. According to Borlena and Achim (2010), it is well known in the financial literature that profitability is the main goal of any corporation and that is the best measure of performance.

2.3 Size

The company's size can be represented by several parameters including volume of workers, how many branches established or total assets. Malik (2011), Omondi and Muturi (2013), Al-Shami, (2013), Burca and Batrinca (2014) and Çekrezi (2015) are among of researchers in related field that used the total assets of companies as a parameters of size. Size of firm is deemed to be important variable as it indicates that bigger firm are running well in the industry, operating at an economical scale then enjoying higher profit (Flamini, McDonald, & Schumacher, 2015).

According to P. Hardwick (1997), the large insurance companies are better than small insurance company as they can attain operational cost efficiencies via increased production, cost savings in product innovation and process development. A positive correlation between the size of the companies' financial performance is intended since the large companies have more fund, greater diversification of risk and better expenses management of expenditures.

2.4 Capital

According to Wani and Dar (2015), Capital is referred as a good indicator of financial robustness of insurance company. An adequate capitalisation is important to preserve policyholder and encourage the robustness and effectiveness of financial system. It implies whether the insurer has enough capital to digest the losses resulting from the claims. Capital is most used by the researcher as among the factors that influenced the insurer's profitability as it shows the financial strength of the insurer. A positive correlation between the capital and insurers' profitability is intended, since a better equity's flow could leads to better financial stability and create opportunity to expand the businesses.

Berhe and Kaur (2017) stated that the capital adequacy is expressed by ratio of equity to asset. Capital adequacy is representing the companies' financial stability and the capability of company to survive in the market for long term period. The impact of greater capital adequacy leads to soundness financial that can attract more policyholder. In other words, in times of failure or bankruptcy, insurance companies with higher assets presumed to be secure. Otherwise, the greater insurers' equity to asset ratio, the lesser the risk faced, which could attributes to increase their loan price. Consequently, insurers will have lower cost of funding. Furthermore, companies with greater equity to asset ratio will have less demand to raise funds from external sources.

2.5 Premium growth

Empirical evidences reveal that a quick increase in volume of premium is one of the causes of insolvency of insurance companies (Kim, Anderson, Amburgey, & Hickman, 1995). Insurance companies having more assets have higher opportunity of becoming profitable (Ullah, Faisal, & Zuhra, 2016). However, too concerned with development may result to structure destruction as other critical goals can be overlooked (Meshari & Aemiro 2013).

According to Lire and Tegegn (2016), premium growth is a proxy to imply the market potential's rate. This means that insurance companies have a better chance of being competitive over the years. This occurs if they earn revenue from the premium received if undue advertising attention is given to increasing premiums with a proportionate allocation of resources to control their investment portfolios.

2.6 Underwriting risk

According to Adams and Buckle (2003) underwriting risk highlights the efficacy of the underwriters and represents the adequacy of the underwriting quality of the insurers. Fama and Jensen (1983) argued that an insurer need to have more stable cash flows if they engaged in risky activities compared to company that averse to risk taking. Therefore, all of companies in insurance industry is expected an inverse relationship of underwriting risk towards financial performance because when taking too much underwriting risk, it could increase the cost and give an impact to the stability of company.

Clear underwriting guidelines are essential to the financial performance of insurers. The risk of underwriting depends on the life insurers' risk appetite (Wani & Dar 2015). Besides that, Santomero and Babble (1997) described that clear guidelines of underwriting are essential to the success of an insurance company including optimal reliable risk estimation and appropriate exposure pricing. Most of companies should seek the acceptance at standard rates of a large majority of risks, but always implement adjusted premiums that considered of loss experience and other risk factors that do not follow uniform requirements.

2.7 Expense ratio

According to Kramaric, Miletic and Pavic (2017), expense ratio is an operating expense ratio to gross net premium rate. In other words, its measures the amount of earned premium rate to be charged by an insurance company to cover the costs generated in the business. The goal of each insurance company is to increase premiums while at the same time decreasing expenses. Higher operating cost have a significant effect on the income of insurance companies, therefore negative influence of this variable is expected.

Rating (2016) stated that the expenditure ratio reflects insurance operations' efficiency. An insurance companies' expense ratio would be evaluated by business class, along with the same pattern. Tomar and Sainy (2019) explained that the expense ratio can be calculated by the ratio of management's expenses to gross direct premium which reveals how much level of income is being utilized for expenses on management.

3. METHODOLOGY

3.1 Theoretical Framework

Figure 3.1: Theoretical Framework of study

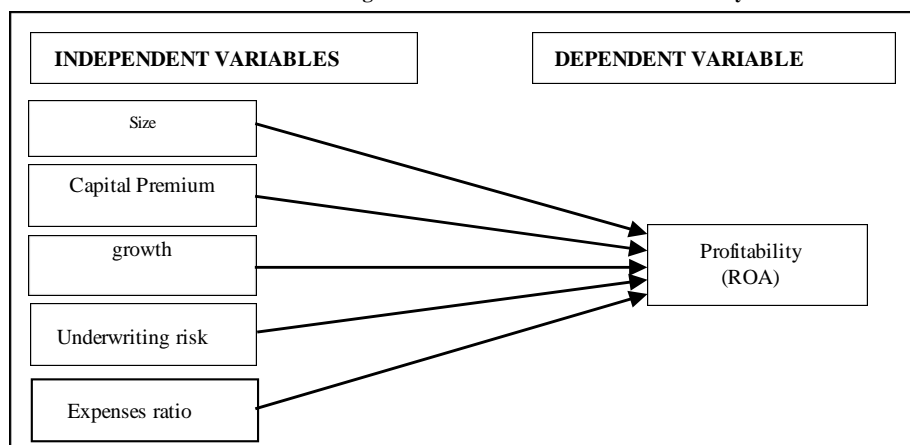

The research framework shows in Figure 3.1 is based on literature review as stated in previous studies. It would give a clear picture of the variables used in this study that related to performance of family takaful operators in Malaysia. Performance in this study is proxy by profitability and was used as the dependent variable. Five independent variables are used in this study that representing operational specific factor (OSF) which are size, capital, premium growth, underwriting risk and expense ratio.

3.2 Hypotesis

Table 3.1 : Summary of hypothesis

	Hypothesis
H_{a1}	There is a significant relationship between size and profitability of family takaful operators in Malaysia.
H_{a2}	There is a significant relationship between capital and profitability of family takaful operators in Malaysia.
H_{a3}	There is a significant relationship between premium growth and profitability of family takaful operators in Malaysia.
H_{a4}	There is a significant relationship between underwriting risk and profitability of family takaful operators in Malaysia.
H_{a5}	There is a significant relationship between expense ratio and profitability of family takaful operators in Malaysia.

3.3 Variables' Measurement

Table 3.2 : Summary of the Variables' Measurement used in the Study.

Category	Variables	Measurement / Ratio used	Authors
Dependent variable	ROA	Profit before tax / Total Assets	Mwangi and Iraya (2014), Sambasivam and Ayele (2013), Akhtar, Ali and Sadaqat (2011), Almajali, Alamro and Al-Soub (2011)
	Size	Natural log of total assets	Wanjugu (2014), Bawa and Chatta (2013), mwangi and Iraya (2014), Lee 2014 and Kumah-Ababio (2018)
Independent Variables	Capital	Total equity / Total asset	Wani and Dar (2015), Krispa and Ajaslla (2016) and Berhe and Kaur (2017)
	Premium growth	GWP(t) –GWP(t-1) / GWP(t-1)	Charumati (2012), Lire and Tegegn (2016), Meshari and Aemiro (2013), Lee 2014, Mwangi and Iraya (2014) and Pjanic, Milenkovic, Kalas and Mirovic (2018).
	Underwriting risk	Benefit Paid / Net premium	Ullah, Faisal and Zuhra (2016), Lire and Tegegn (2016), Charumati 2012, Adams and Buckle (2000)
	Expense ratio	Commissions and management expenses / Net earned premium	Mwangi and Iraya (2014), Lee 2014, Tomar and Sainy (2019)

4.0 RESULTS AND DISCUSSION

4.1. Descriptive Statistics

Table 4.1: Descriptive statistics of the variables for Family Takaful operators.

Variable	Obs	Mean	Std. Dev.	Min	Max
ROA	66	0.399	3.008	-10.820	7.940
Size	66	14.712	1.761	12.000	19.00
Capital	66	0.159	0.100	0.074	0.658
Premium Growth	66	2.205	16.268	-0.318	132.314
Underwriting risk	66	2.259	1.702	0.490	8.870
Expense ratio	66	0.435	0.115	0.207	0.753

Table 4.1 shows the descriptive statistics of six variables which are ROA, Size, Premium growth, expense ratio, capital and underwriting risk of 11 Family Takaful operators in Malaysia for six years. So there are 66 observations for this study. As we can see the result above, the mean value of ROA is 0.399 and the standard deviation is 3.0078.

The maximum value of ROA is 7.940, while the minimum value is -10.820. This shows that the profitability of Family Takaful operators can be either generated or degenerated from their assets.

The mean value of Family takaful operator size ((lnTA) is 14.712 and the standard deviation is 1.761 whereas the maximum value of takaful operator Size is 19 while the minimum value is 12. Besides that, the mean value for Family takaful operator's capital is 0.159 and the standard deviation is 0.100. Capital has a maximum value of 0.658 and minimum value of 0.074. For Family takaful operator Premium growth the mean value is 2.205 and the standard deviation is 16.268 whereas the maximum value of Family takaful operator premium growth is 132.314 while the minimum value is -0.318. Otherwise, the mean value of Family takaful operator's underwriting risk is 2.259 and the standard deviation is 1.702. The maximum and minimum value for underwriting risk are 8.870 and 0.490 respectively. Lastly, the mean of expense ratio is 0.435 while the standard deviation is 0.115. The maximum and minimum value of expense ratio are 0.753 and 0.207 respectively.

4.2 Panel Data Test Analysis

Table 4.2: Hausman Test for family takaful operators.

Test	Family takaful operators (Prob. Chi-Square)
Hausman Test	0.0000**

Note: *p<0.05, **p<0.01

Table 4.2 shows the Hausman test is employed to decide between fixed or random effects and most suitable for the model in this study. The family takaful operators result of Hausman test recorded chi-square score at 0.0000 ($p < 0.01$) which meet the asymptotic assumption so reject the null hypothesis, it is concluded that the fixed effect is selected for this study. Similarly to life insurance companies' Hausman test recorded the chi-squares score at 0.0000 ($p > 0.01$). The test also meet the asymptotic assumptions and reject the the null hypothesis as well and concluded that fixed effects model is most appropriate model for this study.

4.2 Fixed Effect Regression Model Analysis

Table 4.3: Regression Analysis for Family Takaful operators

	Coefficient	Std. Error	p- value
Size	-0.621**	(0.188)	0.002
Capital	-9.764*	(4.405)	0.034
Premium Growth	-0.003	(0.025)	0.898
Underwriting risk	-0.357*	(0.201)	0.080
Expense ratio	-7.870*	(2.771)	0.006
Intercept (baseline)	15.329***	(3.198)	0.000
R-squared = 0.4012			
Adjusted R-squared = 0.3513			
F-statistic = 8.04			
N = 66			

Statistical significance: ***<0.01, **<0.05, *<0.10

Table 4.3 shows the family takaful operators' regression analysis of ROA by using Fixed Effect (FE) model. The table shows the ROA as the dependent variables and family takaful operator's size, premium growth, expense ratio, capital and underwriting risk as independent variable. This model has the high good of fitness among the variables with R-squared 0.4012 which means the proportion of ROA is explained by the independent variables at 40.12%.

Based on the result provided, there are four independent variables that have significant relationship with dependent variable which are size, capital, underwriting risk and expense ratio. Size has negative coefficient which is -0.621 at 0.002 significant level with standard error of 0.188. The capital also shows the negative coefficient of -9.764 at 0.03 significant level with standard error of 4.405. Same result shows by underwriting risk variable with negative coefficient of -0.357 at 0.80 significant level with standard error of 0.201. Expense ratio also has negative coefficient which is -7.870 at 0.006 significant level with standard error 2.771.

There is one independent variables that show insignificant relationship and has a negative coefficient with ROA which is premium growth and. Thus, the researcher develops the multiple linear regression equation as below to

interpret the model.

$$ROA_{it} = 15.329 - 0.621SIZE_{it} - 9.764CAP_{it} - 0.003PG_{it} - 0.357UR_{it} - 7.87ER_{it} + \mu_{it}$$

From the equation above, it can be explained that, one unit of size increase contributes to decrease of 0.621 units of profitability. Otherwise, increasing of one unit of Capital will contribute to the decreasing of 9.764 units of profitability. Besides that, one unit premium growth increase, contributes to decrease of 0.003 units of profitability and when one unit of underwriting risk increases, the profitability will decrease by 0.357 units. The result also reveals that, when one unit of expense ratio increase would contribute to decrease of 7.87 units of profitability.

From the analysis, the most influential determinants of operational specific factors for family takaful operators that give an impact towards the profitability are capital followed by expense ratio, size, underwriting risk and premium growth.

5.0 CONCLUSION AND RECOMMENDATION

5.1 Relationship between operational specific factors (OSF) and profitability of family takaful operator

5.1.1 Size and Profitability

The result from the analysis that has been done used Fixed Effect method shows that. Size has significant connection with profitability for family takaful operator in Malaysia. Therefore, in this study, the researcher fails to reject the first hypothesis H_{a1} . The coefficient of the size showed the negative relationship towards profitability. It is aligning with study done by Ullah, Faisal and Zuhra (2016) which stated that the size can be negative correlated for financial institutions due to the bureaucratic processes, agency cost and inflexibility. Moreover, the bigger company tends to have the higher ratio of losses provision to maintain their total assets. This would give the negative impact towards profitability

5.1.2 Capital and Profitability

Capital is one of the factors that being discussed before as the significant determinant of profitability. From the findings above, this determinant shows significant relationship between them. Therefore, the researcher fails to reject the second hypothesis, H_{a2} . It shows the negative effect to profitability. This negative impact to profitability could indicate that the profitability will decrease when the capital is increase. This result supported the previous studies done by Bawa and Chatta (2013) and Yero (2015). The negative significant correlation may be due to unstable market condition, therefore it is recommended that family takaful operators make an effort to be prudent when raising capital.

5.1.3 Premium growth and Profitability

The analysis result for premium growth and profitability relationship for family takaful operator in Malaysia was insignificant and shows negative result. Therefore, the researcher rejects the third hypothesis, H_{a3} . The study shows that premium growth has no effect to the profitability for takaful industries. This is in line with some previous studies, which the premium growth is not significant with profitability by Mehari and Aemiro (2013), Mwangi and Iraya (2014), Lee (2014), Ullah, Faisal and Zuhra (2016) and Cheng and Wong (2004). Generally, Premium growth tests the penetration level of the industry. Being too focused on premium growth can lead to self-destruction as it would be possible to ignore other important goals. (Kim, Anderson, Amburgey & Hickman, 1995)

5.1.4 Underwriting Risk and Profitability

The analysis of correlation between underwriting risk and profitability for family takaful operators shows that there is significant correlation between the underwriting risk and profitability. Thus the researcher failed to reject the fourth hypothesis, H_{a5} . For family takaful operator the result shows negative relationship between them. The result is aligning with previous studies done by Ullah, Faisal and Zuhra (2016), Lire and Tegegn (2016). The negative results indicate that low risk of underwriting has a positive effect on profitability. Lire and Tegegn (2016) concluded that underwriting risk has a negative impact on the profitability of the insurer, because taking an excessive risk of underwriting can affect the sustainability of the business through higher costs.

5.1.5 Expense ratio and Profitability

Based on the result, the expense ratio shows the significant correlation with profitability for family takaful operator. Therefore, the researcher fails to reject the fifth hypothesis, H_{a5} . The relationship result also shows negative coefficient that indicates that expense ratio would give a negative impact towards family takaful operator's profitability as per expected before. This result supported the previous research done by Mwangi and Iraya (2014) that concluded that the low expenses ratio produce positive effect on profitability. Thus, the results suggesting to reduce expenses of the firm in order to increase the profitability of firm through organized the companies' expenses effectively by management to earn higher returns than competitors (Hardwick, 1997).

5.2 Limitation and recommendations of Study

Based on above findings, we can see that the operational specific factors (OSF) that gave most impact towards profitability that being proxy of determinant of performance for family takaful operators is capital. It is important for the organization of family takaful operator to concern about their capital management in order to strengthen their capital since this could enable them to resist financial crises as well as to ensure safety to the customers in times of economic instability and crisis. The researcher also recommends family takaful operators to increase their capital structure by increasing the equity of the company. It is because, the willingness of the shareholders to invest in the company will contribute to the higher profitability. Otherwise, the resilience of the capital structure will enhance its risk-taking capacity and strengthen its funding capacity, and eventually lead to increased profitability.

Besides that, Family takaful operators should concern about their operational specific factors (OSF) that tested and had significant relationship towards profitability in this study such as size, expense ratio and underwriting risk. They need to measure, manage and control such factors that give an impact towards profitability in order to maintain and increase their profitability as well as their performance.

As a recommendation to the future research, the future researcher is advised to increase the time period of study which is more than six years. Besides that, they maybe can try to do a comparative research among the general takaful operators and general insurance company to test on their businesses. Future researcher may also do a comparison analysis towards local and foreign takaful operators and insurance companies in Malaysia. Other than that, the researcher also recommends to add more variables in future studies regarding the operator's specific factors (OSF) that will balance the whole management of the takaful such as the liquidity, investment yield, and leverage ratio. At the same time maybe the determinant factor could be included the macroeconomics factors such as Gross Domestic Product (GDP), inflation rate, and Price Index (CPI).

5.3 Conclusion

This study, presented the evidential investigation on the performance of 11 family takaful operators conducted using a panel data set over the period of 2013 to 2018. The main objective in this research is to determine the relationship between operational specific factors (OSF) and profitability of family takaful operator in Malaysia. Based on results of Fixed Effect Model regression analysis revealed that companies' size, capital, underwriting risk and expense ratio were statistically significant to profitability of family takaful operators, while premium growth and were negatively related to performance (ROA). Besides that, others objective is to investigate the most influenced of operational specific factors (OSF) towards profitability of family takaful operators in Malaysia and the result shows that the capital is the most operational specific factor that influence or gave most impact towards profitability for family takaful operator and in Malaysia.

REFERENCES

- Abduh, M., Omar, M. A., & Tarmizi, R. M. (2012). The Performance of Insurance Industry in Malaysia: Islamic vis-à-vis Conventional Insurance. *Journal of Islamic Banking and Finance, Volume 29, No. 4*, 40-49.
- Adams, M., & Buckle, M. (2003). The determinants of corporate financial performance in the Bermuda insurance market. *Applied Financial Economics, 13:2*, 133-143.
- Akhtar, M. F., Ali, K., & Sadaqat, S. (2011). Factors Influencing the Profitability of Islamic Banks of Pakistan. *International Research Journal of Finance and Economics*.
- Almajali, A. Y., Alamro, S. A., & Al-Soub, Y. Z. (2012). Factors Affecting the Financial Performance of Jordanian Insurance Companies Listed at Amman Stock Exchange. *Journal of Management Research, Vol. 4, No. 2*, 266-289.
- Al-Shami, H. A. (2013). Determinants of insurance companies' stock return in GCC countries. *PhD. thesis, Universiti Utara Malaysia*.
- Bank Negara Malaysia. (2019). Retrieved from <http://www.bnm.gov.my/index.php?ch=li&cat=insurance&type=L&fund=0&cu=0>
- Bawa, S. K., & Chattha, S. (2013). Financial Performance of Life Insurers in Indian Insurance Industry. *Pacific Business Review International Volume 6, Issue 5*, 44-52.
- Berhe, T. A., & Kaur, J. (2017). Determinants of insurance companies' profitability Analysis of insurance sector in Ethiopia. *International Journal of Research in Finance and Marketing (IJRFM) Vol. 7 Issue 4*, 124-137.
- Borlea, S. N., & Achim, M. V. (2010). Business performances: Between profitability, return and growth. *Annals of University of Craiova-Economic Sciences Series, 2(38)*.
- Burca, A., & Batrinca, G. (2014). The Determinants of Financial Performance in the Romanian Insurance Market International. *Journal of Academic Research in Accounting, Finance and Management Sciences, 4, 1*, 299-308.
- Çekrezi, A. (2015). Determinants of Financial Performance of the Insurance Companies: A Case of Albania. *International Journal of Economics, Commerce and Management, Vol III, Issue 4*.
- Charumathi, B. (2012). On the Determinants of Profitability of Indian Life Insurers – An Empirical Study. *Proceedings of the World Congress on Engineering 2012 Vol 1*.
- Chen, R., & Wong, A. K. (2004). The Determinants of Financial Health of Asian Insurance Companies. *The Journal of Risk and Insurance, Vol. 71, No. 3*, 469-499.
- Das, U. S., Davies, N., & Podpiera, R. (2003). Insurance and Issues in Financial Soundness. *IMF Working Paper*. Fama, E. F., & Jensen, M. C. (1983). Agency Problems and Residual Claims. *Journal of Law and Economics, 26*. Harwick, P., & Adams, M. (1999). Firm Size and Growth in the UK Insurance Industry. .
- Heikal, M., Khaddafi, M., & Ummah, A. (2014). Influence Analysis of Return on Assets (ROA), Return on Equity (ROE), Net Profit Margin (NPM), Debt To Equity Ratio (DER), and current ratio (CR), Against Corporate Profit Growth In Automotive In Indonesia Stock Exchange. *Journal of Academic Research in Business and Social Sciences, 4*.
- Kim, Y. D., Anderson, T. L., Amburgey, & Hickman, J. C. (1995). The use of event History Analysis to examine insurers insolvencies. *Journal of Risk and Insurance, 62*, 94-110.
- Kramaric, T. P., Miletic, M., & Pavic, I. (2017). Profitability Determinants of Insurance Markets In Selected Central And Eastern European Countries. *International Journal of Economic Sciences Vol. VI, No. 2*, 100-123.
- Kripa, D., & Ajasllari, D. (2016). Factors Affecting the Profitability of Insurance Companies in Albania. *European Journal of Multidisciplinary Studies Vol.1 Nr. 1*, 352-360.
- Kumah-Ababio, C. (2018). The Effect of Capital Structure on Profitability of Insurance Companies in Ghana.
- Lee, C.-Y. (2014). The Effects of Firm Specific Factors and Macroeconomics on Profitability of Property-Liability Insurance Industry in Taiwan. *Asian Economic and Financial Review*, 681-691.
- Lim, J., Idris, M. F., & Carissa, Y. (2010). History, Progress and Future Challenge of Islamic Insurance (Takaful) In Malaysia. *Oxford Business & Economics*.
- Lire, A., & Tegegn, T. (2016). Determinants of Profitability in Private Insurance Companies in Ethiopia. *Journal of Poverty, Investment and Development, Vol.26*, 85-92.
- Malik, H. (2011). Determinants of Insurance Companies Profitability: An Analysis of Insurance Sector of Pakistan. *Academic Research International, Volume 1, Issue 3*, 315-321.
- Mazviona, B. W., Dube, M., & Sakahuhwa, T. (2017). An Analysis of Factors Affecting the Performance of Insurance Companies in Zimbabwe. *Journal of Finance and Investment Analysis*.
- Mehari, D., & Aemiro, T. (2013). Firm Specific Factors That Determine Insurance Companies' Performance in Ethiopia. *European Scientific Journal, Vol. 9, No.10*, 245-255.
- Mwangi, M., & Iraya, C. (2014). Determinants of Financial Performance of General Insurance Underwriters in Kenya. *International Journal of Business and Social Science, Vol. 5, No. 13*, 210-215.
- Omondi, M., & Muturi, W. (2013). Factors affecting the financial performance of listed companies at the Nairobi Securities Exchange in Kenya. *Research Journal of Finance and Accounting*, 99-104.
- P. Hardwick. (1997). Measuring Cost Inefficiency in The UK Life Insurance Industry Applied Financial Economics. *Administrative Science Quarterly 45(1)*, 81-112.
- Pjanic, M., Milenkovic, N., Kalas, B., & Mirovic, V. (2018). Profitability Determinants of Non-Life Insurance Companies in Serbia. *Original Scientific Paper*, 333-345.
- Rating, C. (2016). Financial Ratios – Insurance Sector.
- Sambasivam, Y., & Ayele, A. G. (2013). A Study on the Performance Of Insurance Companies in Ethiopia. *International Journal of Marketing, Financial Services & Management Research, Vol.2, No. 7*, 138-150.
- Santomero, A. M., & Babbel, D. F. (1997). Financial risk management by insurers: An analysis of the process. *Journal of Risk and Insurance, 64(2)*, 231-270.
- Smajla, N. (2014). Measuring Financial Soundness Of Insurance Companies By Using Caramels Model – Case Of Croatia. *Interdisciplinary Management Research, vol. 10*, 600-609.
- Thajudeen, K. S. (2015). IFSA 2013: Rationale, Salient Features and Possible Issues.
- Tomar, P., & Sainy, M. (2019). Profitability analysis of Insurance companies: A case of Private Non-life Insurers ABSTRACT Dr Rajiv Gupta.
- Ullah, G. M., Faisal, M. N., & Zuhra, S. T. (2016). Factors Determining Profitability of the Insurance Industry of Bangladesh. *International Finance and Banking, Vol. 3, No. 2*, 138-147.
- Wani, A. A., & Dar, S. A. (2015). Relationship between Financial Risk and Financial Performance: An Insight of Indian Insurance Industry. *International Journal of Science and Research (IJSR), Volume 4, Issue 11*, 1424-1433.
- Wanjugu, M. J. (2014). The Determinants of Financial Performance in General Insurance Companies in Kenya. . Yero, W. S. (2015). Capital Structure and Financial Performance: Evidence from Listed Insurance Firms in Nigeria.

THE AWARENESS TOWARDS ZAKAT OBLIGATION AMONG UNIVERSITY STUDENTS: A STUDY IN UNIMAP

Nor Jannah Ismail & Zainordin Zinon Abidin

Universiti Utara Malaysia, Malaysia.

Abstract

Zakat is one of the important instruments in the economics of Muslims. Islam has laid down clear rules and regulations on zakat which is a religious obligation. The purpose of this study to examine the awareness towards zakat obligation among university students. The aim of this study is to investigate how independent variable which is contained of religiosity, knowledge, attitude, medium promotion, influenced the awareness towards zakat obligation. Besides, this study also trying to determine the relationship between all the variables mentioned. There are 365 respondents involved in this study while the test conducted are analysis descriptive correlation and regression. The findings indicated that there a positive and significant relationship between religiosity, knowledge, attitude, medium promotion and awareness towards zakat obligation. The multiple regression analysis also found that religiosity, knowledge, attitude, medium promotion is influenced and have its own impacts towards the awareness on zakat obligation among university students.

Keywords: Zakat, Awareness, Religiosity, Knowledge, Attitude, Medium Promotion

1.0 INTRODUCTION

Islamic Financial Planning is an integral part of individual life as a prudent financial management and it that can help alleviate the financial burden as well as ease human life in this world. The meaning of Muslims' life is to elevate the desire of Muslims needed not only to pursue material gratification but also to inquire about Allah Almighty's grant for success in this world and hereafter. We need to enter Islam as a whole as a Muslim, therefore, Muslims are encouraged and planned their lives prudently and financially to accomplish the goal of Shariah in the community, business and finance that lead to success and happiness in life. In Surah Yusuf (verses 47-48), Allah Almighty emphasized the crucial of great financial planning whereby people must keep and preserve their wealth within seven years of good harvest and be prepared for seven terrible years. Therefore, Shariah decisions must be adhered to and followed during the whole the process. The essence of Islamic financial planning is a good plan to meet individual goals through.

According to Abdullah and Junaina (2013), financial planning is essential in basic daily life of individuals and their families and financial management awareness from the beginning is best for the future. The concept of Islamic financial planning emphasizes the ultimate goal not only to stop from the practical side but to continue to the Hereafter with an eternal reward. Islamic financial planning is including Islamic income, Islamic expenditure, debt management, protection (risk management) in Islamic, investment, zakat, alms, charity, and waqf.

The concepts of zakat can play an important role in the comprehensive Islamic Financial Planning framework. Zakat, being the third pillar of Islam, is an essential aspect of individual in financial planning. In addition, zakat is a responsibility of the worship of property which is imposed on man kind through the word of Allah SWT in the Quran, and is explained in more detail through the hadith of Prophet Muhammad SAW: And establish prayer and give zakah, and whatever good you put forward for yourselves-you will find it will Allah. Indeed, Allah of what you do, is Seeing. [Al-Baqarah 2: 110] In above verse of the Quran, Allah clearly told to Muslims to issue zakat as obligatory worship such as prayer. Zakat plays the important roles in the Muslim community covering various aspects such as economics, education, law and others.

1.2 Problem Statement

Paying zakat or not paying zakat is accompanying to obedience. Zakat in general is a form of worship as well as other duties of worship such as prayer, fasting and pilgrimage. Despite of compulsory, there are still disobedient individuals to this command (Hairunnizam, Sanep and Mohd Ali, 2007). In religious practice the factor of obedience is very much related to religiosity. Thus the unwillingness to pay zakat symbolizes the reluctance to commit religious orders and gives the impression that the level of religiosity is low. Ghazali (1998) argues that

overcoming disobedience in particular refusing to pay zakat is not an easy task as it relates to the level of faith and attitude. Practically it is difficult to measure but has an impact on belief.

Moreover, in the context of zakat awareness, the religious aspect cannot be ignored because people of high religion will obey zakat compare to the person who are not immensely religious. Religiosity was previously defined as a guideline that Muslims would follow in their daily activities and their judgment of the final decision to fulfil their zakat obligation (Kamil, Zainol, and Saad, 2012). The religiosity influences the person's personality to carry out a good behavior (Kamil et al., 2012). The results show that it is positively and significantly related. In another study, also found that religion and behavior are highly correlated (Alamet.al, 2012)

On the other hand, the obligation to pay zakat is distinctly explained in the Qur'an and Sunnah, however, some Muslims do not bother the command obligatory zakat of their income. Although it is recognized of the zakat obligation, the annual zakat collection is still lower than the income tax collection, even it has been given tax rebates to individual who issue zakat (Saad and Haniffa, 2014). Some individuals consider tax payments equal to zakat and assume that if they have paid taxes than they have no the responsibility of zakat. The implementation of both methods requires further explanation and clarification (Hamid, 1998).

Zakat collection among Muslims in Malaysia is moderate based on statistics released in 2014 by the PPZ despite being described as one of the obligations in the Quran since Muslims are still less aware of zakat (Abashah et al., 2018). Although the amount looks rather big in every year, nevertheless the amount of zakat collected is still insufficient to distribute to asnaf due to the increasing number of asnaf and receiver each year. (Ali et al., 2017).

According to Khamis et al. (2014) people are still unaware and unclear about the conditional of zakat. Fuadah, et al. (2014) found the level of understanding of Islamic principles is one of the factors influencing zakat payment intention. Some people assume that if they have paid the tax, then zakat payment will not have to perform. Besides that, attitude to pay zakat is related with individual belief about the personal impact of outcomes. Huda et al. (2012) stated attitude toward the nature of paying for zakat, subjective norm and regulation of actions among the factors driving the intention to pay. Khamis et al. (2014) found that low attitude among Muslim workers and is also due to poor enforcement of Zakat officials is affect low zakat collection in Malaysia.

2.0 LITERATURE REVIEW

2.1 Concept of Zakat

Zakat literally acquired from the Arabic root word that mean of "which purifies", as well as "that which fosters", i.e. growth and increase (Siddiqi, 1968, p. 28; Mannan, 1986). Zakat means to grow and to increase (Al-Qardawi, 1999). From the arabic, "The root of the word zakah in Arabic means cleanliness, growth, blessing, and praise. All these meanings of the word are used in Quran and Hadith" (Al-Qardawi, 1999). In Shariah, zakat assigns a part of property that God has set for distribution among the eligible categories (Al-Qardawi, 1999)

Zakat growth is often associated with perform the zakat payment, that can increase wealth and get the reward in hereafter. Paying zakat is a religious duty, as mentioned in the Qur'an, Surah 87 verse 14, to achieve purity and goodness of soul.

He has certainly succeeded who purifies himself.

(Al-Qur'an: Al-A'ala 87, verse: 14)

On the other hand, Zakat's main goal, is to redistribute wealth among the poor. Zakat administration involves two function of collection and distribution. The country's role in the collection and allocation of zakat funds began in the days of the prophet in Medina. The zakat fund und is distributed among the eight recipient as specified in the Quran in surah At-Taubah:

﴿ إِنَّمَا الصَّدَقَتُ لِلْفُقَرَاءِ وَالْمَسْكِينِ وَالْعَدِيلِينَ عَلَيْهَا وَالْمَوْلَةَ
 قُلُوبُهُمْ وَفِي الرِّقَابِ وَالْغَرَامِينَ وَفِي سَبِيلِ اللَّهِ وَأَبْنِ السَّبِيلِ قَرِيضَةً
 مِّنَ اللَّهِ وَاللَّهُ عَلِيمٌ حَكِيمٌ ﴾

“Sadaqat are for the poor and the needy, and those employed to administer (the Zakat), for those whose hearts are to be won over, and for the freeing of human beings from bondage, and (for) those who are burdened with debts, and (for every struggle) in Allah’s cause, and (for) the wayfarer: (this is) an ordinance from Allah, Allah is All-Knowing, full of Wisdom.” (9:60).

From the above verses, there are eight categories of people defined in the Quran as the indigent, the poor, those eligible for zakat, (amil), Muallaf, those who are free from slavery, those who are in debt, those who support the cause of Islam and those who wayfarer. Zakat funds disbursed to eight asnaf now exist in various forms of distribution (Yusof, 2010).

2.2 Awareness

Creating awareness is very important as it helps the general public and young generation to understand and recognize the importance of zakat. Zakat awareness is understanding a mechanism to achieve and fulfil the needs of wealth purification. Zakat awareness creates a value of the importance to purify the wealth based on Islamically legal ways. Allah (S.W.T) says *“But if they give up willingly to you anything of it, then take it in satisfaction and ease.”* (Al-Quran, 4:4). Previous studies on zakat not paying enough attention on the importance of its awareness. Zakat awareness creates high potential knowledge of a person to be aware regarding the tools of Islamic wealth purification.

Awareness on zakat obligation payment tools and their influence on people’s behavior have been covered in few studies. For example, Bakar and Rashid (2010) have found that level of awareness of social responsibility, some property has rights other people and zakat income is a religious duty that has driven to pay the income zakat. Whereas mechanisms, way and methods zakat payments are also an incentive factor for an employee to pay zakat. Ellany and Lateff (2011) found two factors that religious understanding and awareness of paying zakat are the most influential among other factors.

Besides that, Awareness levels sometimes vary when it comes to age, gender, and income level. According to (Amin, 2007) customer of Borneo Islamic automobile financing have same level awareness supported by age, marital status and occupation. Despite the awareness of the existence of the Islamic product, however they reluctant to choose Islamic product. People who are considered of being aware of Islamic banking products cannot be considered that they are willing to get involved in the halal products (Rammal and Zurbruegg, 2007).

2.3 Religiosity

Frequently the common factors discussed in the zakat payment are religious values because human factors behaviors are related and can affect human social behaviour. (Michell & Al-Mossawi, 1999). According to Shukor and Jamal (2013), religiosity differs from spirituality, which seeks a connection to a non-material reality perceived as a kind of excellence, whereas religiosity is the observance of the external forms of some religious traditions.

Mohd Ali et al. (2004) found that religious level and religious knowledge was found to be the most important factors in awareness among professional staff of the National University of Malaysia of zakat income.

On the other hand, Bakar and Rashid (2010) also found that religious are determine the zakat payments on income and showing a positive relationship. In accordance with the zakat, Kamil, Zainol, and Ram Al Jaffri (2012) discovered that the element assessment of religiosity has four range. The study found that highly religious business owners are also more likely to adhere to zakat laws, and religiosity plays a crucial aspect in zakat-compliant behavior. Zulkifli and Sanep (2010) stated that the compliance of income zakat payments through formal institutions in the Aceh is influenced by the level of individual religion. According to Zainol (2008), an important factor in zakat compliance in relation to individual behavior is religiosity.

However, Kamil (2002) found that public workers in the state of Kedah had perform their zakat is not influence by religiosity. Compliance behavior is intently connected to religious obligations. Definitely, Muslims who do not pay zakat are considered to be people who do not comply with Islamic obligations (Shamsudin, Azman and Tajuddin, 2016).

2.4 Knowledge

Perceptions and attitudes are influenced by knowledge (Fallan, 1999). Fallan (1999) found that tax knowledge changed the attitudes and perceptions of the students regarding the distribution of taxes. Studies show that

improved tax awareness improves the sense of justice among students in tax distribution, which may increase their chances of paying taxes.

The level of knowledge about zakat, influence Muslim's decisions on zakat payments. Ali, Hairunnizam & Nor Ghani (2004) found that those who were exposed to knowledge has a high degree of awareness in the payment of zakat income. Awareness in performing this worship should be emphasized because compliance is considered a faith in every Muslim. It is related to the level of knowledge individuals about the zakat.

In addition, the knowledge that is being observed from individual Malaysian taxpayers and prove that knowledge on tax is important factors that influence tax compliance (Mohd Rizal, 2010). Furthermore, Natrah (2014) found that tax awareness inadequacy is a major element in tax exception behaviour. Therefore, Muslim need to clearly understand the basics of knowledge of zakat that consists of zakat terms, perfect title, nisab, distance, type of property subject to zakat calculation, zakat calculation, zakat recipients, zakat laws and current zakat laws are based on current circumstances (Mohd Safri, 2006). People with high levels of knowledge will have a high awareness of zakat payments compare to the people who had low knowledge. Moreover, Zulkifli and Sanep (2010) indicates that understanding about zakat essentially influenced zakat compliance.

2.5 Attitude

Ajzen and Fishbein (1980) assess attitude as the index of the degree at which a person likes or dislikes an object; the attitude of a person to his conduct is determined by the set of beliefs he holds for his conduct.

Zainol and Faridahwati (2013) found that attitudes, and subjective norms, definitely affect taxpayer's intention Goods and Service Tax (GST) enforcement. Sapingsi et al. (2011) disclose that only attitude and behavioral control were considered to have an important relationship with the intention of paying zakat. This study shows that attitudes are critical not only affect tax compliance behaviours, as well as compliance behaviours with zakat.

Besides that, Ram Al-Jaffri and Roszaini (2014) emphasize the findings by given prove that intention is an essence of zakat obedient and that both subjective norms and attitudes influence intentions. Additionally, Taib et al. (2008) found that the recognition partnership home financing and the degree of acceptance of that financing have significant on attitude of postgraduate students.

2.6 Medium Promotion

The medium of information distribution is crucial in the dissemination of knowledge and awareness to individuals. It is considered a tool in the dissemination of information through print, electronic media, formal education and informal. Individuals who are extremely exposed to information about zakat are likely to fulfill the zakat obligation (Azman, Zainudin and Musafar Hameed, 2014).

According Osman, Haji Othman, Rana, & Lin (2016) life insurance purchase decisions are influenced by advertising and promotion. Hairunnizam and Sanep (2013) revealed the medium of formal distribution in the form of promotions such as mobile exhibitions, amil and zakat officer plays an important and effective role in the awareness of zakat and the institution that administers the zakat. Negative perceptions should be reduced in circles society so that the interests of religion can be implemented effectively and efficiently.

Zakat institutions need to play a proactive role in spreading zakat information through the use of information and communication (ICT) technologies such as website, social media, billboards, annual reports, radio, television and lecture at mosque. This opinion is in line with the public and is not limited to staff only Ismadi et. al (2004).

A study conducted by Hairunnizam, Sanep dan Mohd Ali (2005) found that awareness campaigns need to be implemented to reach and raise awareness for young people as they are a potential target group for paying future income zakat. Kamil (2005) stated that the internal motivating factors affecting the zakat payer were the quality of service, the exposure of the zakat promotion campaign, the knowledge of income zakat and the religious factors. Accordingly, the study was conducted by Nur Azura, Norazlina and Nor Fadzlin (2004) in the UUM that a high percentage of respondents propose UUM administrators to provide talks, workshops and courses to give aggressive awareness of income zakat to their staff. The study is more focused to the importance of using the medium of communication in communicating information about income zakat. Hairunnizam et al. (2009) found that an inadequate dissemination of information about the zakat distribution make the zakat payer discontented and this is significant to the promotion by Zakat institution.

3.0 METHODOLOGY

3.1 Theoretical Framework

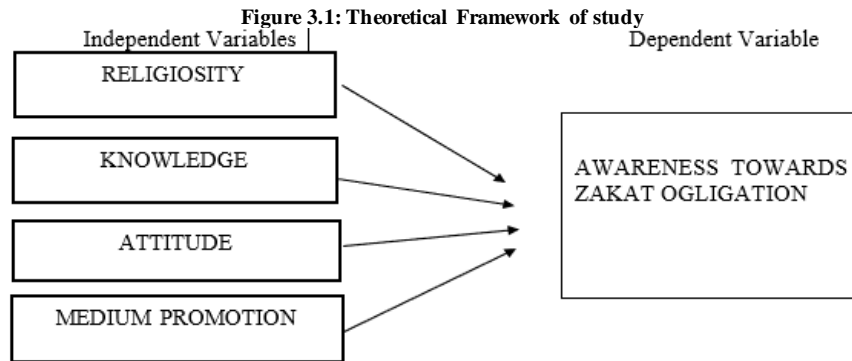

The theoretical model comprises the awareness on zakat obligation as a dependent variable and four factors, which have been identified in the literature, as an independent variable. The factors are religiosity, knowledge, attitude, and medium promotion.

3.2 Hypothesis

3.2.1 Hypothesis 1:

Ho1: There is no relationship between religiosity, knowledge, attitude, medium promotion and awareness towards zakat obligation.

Ha1: There is a relationship between religiosity, knowledge, attitude, medium promotion and awareness towards zakat obligation.

3.2.2 Hypothesis 2:

Ho2: There is no significant influence of religiosity, knowledge, attitude, medium promotion and awareness towards zakat obligation.

Ha2: There is a significant influence of religiosity, knowledge, attitude, medium promotion and awareness towards zakat obligation.

4.0 RESULTS AND DISCUSSION

4.1 Cronbach Alpha

Table 4.1: The Cronbach Alpha for pilot test (n= 50)

Variables	No. of Items	Cronbach's Alpha Value
Zakat Awareness	5	0.855
Religiosity	7	0.883
Knowledge	5	0.693
Attitude	5	0.824
Medium Promotion	5	0.807

Table 4.1 shows the reliability test using Cronbach's Alpha. The value of Cronbach's Alpha ranges between 0.693-0.883, if the value is closer to 1, it shows that the data has high reliability of internal consistency.

4.2 Profile Respondent

Table 4.2: Profile of the respondents (n=365)

Variable	Categories	N	(%)
1.Gender	Male	231	63.3
	Female	134	36.7
2.Age	18 – 20 years	136	37.3
	21 – 23 years	217	59.5
	> 24 years	12	3.3
3.Marital status	Single	363	99.5
	Married	2	0.5
4.Financial support	Educational Loan	308	84.4
	Scholarship	34	9.3
	Family support	21	5.8
	Saving	2	0.5

Table 4.2 shows that 63.3% are male respondents, while 36.7% are female respondents. The respondent from the age group > 24 years old is 3.3%, while 21-23 years old is dominant among UniMAP undergraduate students with 59.5% and 18-20 years old with 37.3%. Marital status of students shows 99.5% are single and 0.5% married. Lastly, financial support which 84.4% is from educational loan, 9.3% from scholarship, followed by family support with 5.8%, and from saving only 0.5%.

4.3 Descriptive Analysis

Descriptive analysis has been used to analyse dependent variable on Zakat awareness and the factors religiosity, knowledge, attitude and medium promotion. A descriptive analysis of all the variables is presented in the Table 4.3 below.

Table 4.3: Level of Factors Zakat Awareness, Religiosity, Knowledge, Attitude and Medium Promotion

Variable (N =365)	Minimum	Maximum	Mean	Std. Deviation
Zakat Awareness	4	5	4.6855	0.36121
Religiosity	4	5	4.60	0.342
Knowledge	3.20	5	4.5436	0.44548
Attitude	4	5	4.7123	0.35049
Medium Promotion	2.80	5	4.4329	0.50624

Table 4.3 show the mean values of the independent variables, religiosity, knowledge, attitude and medium promotion are 4.60, 4.5436, 4.7123 and 4.4329 respectively. While mean value of zakat awareness for dependent variable is 4.6855. In this variables there 4 question that has been asked to indicate the level awareness towards zakat obligation. All the items in variable of zakat awareness is at high scores of agreements. The item "Saya sedar bahawa pembayaran zakat adalah penting untuk meningkatkan ekonomi muslim" is the highest mean score 4.73 followed by the item "Saya sedar membayar zakat adalah tanggungjawab saya sebagai seorang muslim with 4.70. This indicates that the awareness towards zakat obligation among UniMAP students is at the highest level.

From all the variables, the score of standard deviation range between 0.342 and 0.5624. These values indicate that there is a commonality in answering the questionnaire among respondents. In other words, the respondents' answers are considered same from one to another.

4.4 Reliability Test

The reliability testing was performed after factor analysis before proceeding further test. Table 4.4 shows the Cronbach Alpha values for the dimensions comprise in this study after factor analysis. For Religiosity variables, factors showed a good reliability is dimensions on Belief where the Cronbach Alpha values was 0.825 while dimensions of Worship with 0.664. On the other hand, Knowledge, Attitude,

Medium Promotion and Zakat Awareness also showed good reliability where the Cronbach Alpha values were well above 0.8.

Table.4.4 : Reliability Test after Factor Analysis

Variables	Dimensions	Item	Cronbach Alpha Values
Religiosity	Belief	R1, R2, R3, R6, R7	0.796
	Worship	R4, R5	0.692
Knowledge		K1, K2, K3, K4, K5	0.840
Attitude		ATT1, ATT2, ATT3, ATT4, ATT5, ATT6	0.831
Medium Promotion		P1, P2, P3, P4, P5	0.861
Zakat Awareness		AW1, AW2, AW3, AW4, AW5	0.850

4.5 Correlation Analysis

Correlation analysis apply to identify the nature of relationship that exists between independent variables which are religiosity, knowledge, attitude and medium promotion while dependent variables is the level of awareness on zakat. Pearson correlation was run to analyze the data collected. In this study the propose Hypothesis 1 respectively as follow:

H₀: There is no relationship between religiosity, knowledge, attitude, medium promotion and awareness of zakat obligation.

H_a: There is a relationship between religiosity, knowledge, attitude, medium promotion and awareness of zakat obligation.

Table.4.5: Correlation between Determining Factors and the Zakat awareness

Variables	Correlation	Significant Level
Zakat Awareness	1.000	.000
Religiosity		
Belief (<i>Aqidah</i>)	.353**	.000
Worship (<i>Ibadah</i>)	.348**	.000
Knowledge	.471**	.000
Attitude	.596**	.000
Medium Promotion	.329**	.000

**Correlation is significant at the 0.01 level (2-tailed)

Table 4.5 shows the correlation findings matrix between awareness on zakat obligation and religiosity. The relationship between the two variables in Pearson is 0.353 for the dimension of Belief and 0.348 for the dimension of worship, which is the value of 0.01. A significant value of 0.000 express positive relationship between zakat awareness and religiosity, thus null hypothesis (H₀) is rejected and accept the alternative hypothesis (H_a).

Moreover, knowledge and zakat awareness correlation of Pearson is 0.471, while the significant correlation is 0.01. The significant value of knowledge is 0.000, which suggests a positive relationship between awareness and knowledge of Zakat's obligation, thus null hypothesis (H₀) is rejected and accept the alternative hypothesis (H_a). The level of knowledge is indicating at the moderate level.

In addition, The Pearson attitude correlation is 0.596, while the significant correlation is 0.01. The significant value is 0.000, indicate that there are positive relationship between awareness on zakat obligation and attitude, thereby null hypothesis (H₀) is rejected and alternative hypothesis (H_a) is accepted.

Lastly, variables for medium promotion the Pearson Correlation is stated 0.329. The significant value for medium promotion is 0.000, which express a correlation between awareness of zakat obligation and medium promotion, thereby null hypothesis (H₀) is rejected and accept the alternative hypothesis (H_a). In fact, double stars (**)

indicate that there is a significant relationship of 99 percent between dependent variables and independent variables.

Overall, the correlation all the variables of Hypothesis 1 that association between the awareness of zakat obligation with religiosity, knowledge, attitude and medium promotion with the value of 0.353, 0.348, 0.471, 0.596 and 0.329 are considered as moderate and small but definite relationship. In addition, all of these variables are positively correlated with the awareness on zakat obligation. This means that if one unit of all these three variables increase, the awareness of zakat obligation is also increase.

4.6 Multiple Linear Regressions

Multiple linear regressions are used as an analytical tool to investigate the influence of determinant factors of awareness zakat obligation. Linear regression is used to predict variable values based on other variable values. In this study, the researcher wants to predict the determinants factor of awareness zakat obligation among UniMAP undergraduate students while the variables used to predict are religiosity, knowledge, attitude and medium promotion. The hypothesis was formulated as below:

Ha2: There is a significant influence of religiosity, knowledge, attitude, medium promotion and awareness towards zakat obligation.

Tables 4.6 indicates the result for regression analysis involving variable understudied.

Variable	B	t	Significant Level	Tolerance	VIF
R_Belief	0.030	0.610	.542	.661	1.367
R_Worship	0.103	2.175	.030	.719	1.513
Knowledge	0.210	4.363	.000	.694	1.441
Attitude	0.444	9.498	.000	.732	1.367
Medium Promotion	0.047	1.013	.312	.753	1.328
Constant	1.065				
R	0.652				
R square	0.425				
F Value	53.076				
Sig.	.000				

Multiple regression analysis is conducted in order to determine the relative effect of independent and dependent variables to analyse the hypothesised relationship between factor of religiosity, knowledge, attitude, and medium promotion. As discussed in previous chapter preliminary analysis is performed to ensure that there is no presumption of infringement in performing the regression.

4.6.1 Testing the Regression Analysis Result

In testing regression analysis result the researchers referred to values including F value, R square value, β value and T test significant value.

a. The influence of religiosity, knowledge, attitude and medium promotion towards Zakat obligation awareness.

Multiple linear regression as an analytical tool for studying the influence of knowledge, attitudes and medium promotion towards zakat obligations. Linear regression is used to predict variable values based on other variable values. Therefore, researcher wants to predict the awareness on zakat obligation while the variables used in the prediction are the religiosity, knowledge, attitude and medium promotion.

i) F Test

In this study, multiple regressions can be used to study the influence of independent variables on dependent variables. Table 4.6 illustrates the results obtained from multiple regression analysis. It shows that the variance analysis from the ANOVA table of F statistics generated ($F = 53,076$) were significant ($p = 0.000$) at the 0.05 level. This regression model can be assumed to be statistically significant since the p value is less than 0.05. Therefore, it rejects the null hypothesis (H_0) and accepts the alternative hypothesis (H_a). Thus, results show the

independent variables understudied have a statistically significant influences the Zakat obligation awareness.

ii) R² Test

R-squared is a statistical measure of the mounting of the data for the regression line. It is also known as the determination coefficient or multi-regression determination coefficient. The value of R explains simple correlation between dependent and all independent variables ($R=0.652$), that indicates a good degree of variables interaction. The R² express that percentage of variance obtained in the dependent variables can be explained by the independent variables. The higher value of R² does not necessarily mean goodness at all times but it depends on the objective of the study. The relative influence from table 4.6 between independent and dependent variables indicates that the regression model's R square is 0.425. By converting the figure to percentage, the R² for this model is 42.5 percent. This finding also indicate that 57.5 percent of the variance is explained by variables that is not included in the model.

iii) Significant in β Value

Table 4.6 show the relative influence between independent and dependent variables which the factor attitude has the highest β coefficient score of 0.444 with the t-value 9.498 followed by knowledge 0.210 and Religiosity on worship dimension 0.103 with the t-value 2.175. The lowest highest β coefficient score is from Religiosity on Belief dimension score of 0.030 with t-value 0.610. Thus, attitude is the most influential independent variable on the awareness on zakat obligation among university students. In this study, the objective is to examine the significant influence of religiosity, knowledge, attitude, medium promotion and awareness towards zakat, the researcher has summarized the relationship between the variables such as formula equation below. Hence, the following equation represents of the multiple linear regressions analysis:

$$Y = a + b_1x_1 + b_2x_2 + b_3x_3 + b_4x_4 + b_5x_5$$

$$Y = AW: 1.065 + 0.444 A + 0.210 K + 0.103R(w) + 0.04 (MP) + 0.03 R (b)$$

Where, $a = \text{Intercepts}$, $y = \text{Awareness of zakat obligation}$
 $b_1x_1 = \text{Attitude}$

$b_2x_2 = \text{Knowledge}$
 $b_3x_3 = \text{Religiosity (Worship)}$

$b_4x_4 = \text{Medium Promotion}$

$b_5x_5 = \text{Religiosity (Belief)}$

Based on the above formula, explains that when one unit of attitude increases, then the awareness towards zakat obligation will increase by 0.444 units. Next, one unit of knowledge increase would make awareness towards zakat obligation increase by 0.210 units and one unit of Religiosity worship dimension increase would make awareness towards zakat obligation increase by 0.103 units. Overall of the results, the alternative hypothesis (H_a) is accepted, meanwhile the null hypothesis (H_o) is rejected because the regression model has reached statically significant where the pvalue is less than 0.05. Based on this study, attitude gives most significant influences on the awareness towards zakat obligation because those with high attitude will gives positive impact on the awareness towards zakat obligation.

5.0 CONCLUSION AND RECOMMENDATIONS

5.1 Discussion

The objective in this study is to identify the level of awareness on UniMAP undergraduate students towards zakat obligation. This study shows that there is awareness among UniMAP undergraduate students at the high level regarding on the result in descriptive analysis on dependent variable. The mean value of zakat awareness for dependent variable is at 4.6855. This report that UniMAP students are aware of and informed about zakat payments and their role among individuals and communities in a larger picture.

Second objective in this study is to examine the relationships between religiosity, knowledge, attitude, medium promotion and awareness of UniMAP undergraduate students towards zakat obligation. Regarding on the results of the correlation analysis in testing the hypothesis, it is found that there are positive, moderate relationship and significant between attitude and zakat obligation awareness followed by knowledge, religiosity, and medium promotion at value 0.000 (at level $p < 0.01$, Sig 2-tailed). Therefore, H_01 is rejected. From this study, attitude as the independent variable is ranked to have the highest relationship with awareness on zakat obligation among 52 UniMAP undergraduate students followed by knowledge, religiosity and medium promotion. Attitudes have been shown to have significant and modest effects awareness zakat payment which related study by Raedah, Noormala & Marziana (2011), Kamil (2002), Zainol (2008) and Zainol et al. (2009).

Third objective is to study the influences of religiosity, knowledge, attitude, medium promotion on awareness of UniMAP undergraduate students towards zakat obligation. The results of the regression analysis between all independent and dependent variables found that the value of R was 0.652, therefore H_02 is rejected and H_a2 is accepted. The independent variables understudied have a statistically significant influence the zakat obligation awareness.

5.2 Recommendation

Even though the results show that there is a positive effect of zakat awareness among university students, there is still plan and opportunity for improvement especially in fostering the attitude and knowledge of zakat and thus enhancing increasing of zakat collection to the state. Zakat institutions have to diversify the methods of promotions. Through the medium more often in the delivery of information about zakat afforded educate for students to not be enthusiastic about zakat when they go out to real work field. Medium promotion is a channel that can make a positive impact and deliver important information between the two parties of the zakat administrator and the zakat payer.

The finding show that students prefer a two-way communication in receiving the issue of zakat. Zakat institution is necessary to use opportunities and giving confidence in zakat management. Zakat promotion programs can be done in parallel with using appropriate flat-forms through informal mediums such as lectures or talk, sermons, awareness campaigns and promotional activities. Zakat institutions need to be more creative and innovative in promoting zakat payments for example by promoting zakat through Facebook, SMS and WhatsApp which this medium information more familiar and near to the community today.

Nevertheless, the level of individual knowledge is also one of the factors connects this awareness and the medium of mediation. The background of the individual exposed to zakat produces good results in performing zakat worship. The level of knowledge is either general knowledge or specific knowledge can be realized through the perform of zakat by the graduating student.

The enthusiasm and readiness of these groups to receive information should be used effectively by the Zakat Institution in providing ongoing awareness of the importance of zakat. Apart from that, the responsibility to educate the young generation is not only on the responsible of the Zakat Institution but it is an informal continuing education by the family and society.

Nevertheless, the scope of this study is restricted to find the relationship between religiosity, knowledge, attitude and medium promotion toward awareness on zakat obligation. Research in areas related to larger sources such as articles, books, newspapers or even Zakat-related papers is therefore advisable. Specifically, this study is limited to Perlis Malaysia University. Future research could be extended to conduct a wider population to raise awareness among Muslims about zakat.

REFERENCES

- Abashah, A., Irza Hanie Abu Samah, Umami Naiemah Saraih, Sayang Nurshahrizleen Ramlan, & Syafawati W Muhammad Radzi. (2018). The Impact of Attitude and Subjective Norms towards Zakat Compliance Behavior in Malaysia. *International Journal of Engineering and Technology* 7(3).
- Abdullah, A., & Junaina Muhammad (2013). Ethical Values in Islamic Financial Planning. *Jurnal Pengurusan* 38(2013) 133 - 140.
- Ajzen, I., & Fishbein, M. (1980). Understanding attitudes and predicting social behavior. *EnglewoodCliffs NY Prentice Hall* (Vol. 278).
- Alam, Syed Shah, Che Aniza Che Wel, & Mst Nilufar Ahsan. (2012). Is Religiosity an Important Factor in Influencing the Intention to Undertake Islamic Home Financing in Klang Valley? *World Applied Sciences Journal* 19(7).
- Al-Ghazali. (2009). *Bimbingan Mukminin*. Singapore: Pustaka Nasional.
- Ali, M. A., Afiq, M. D., Shamsudin, A. I., Zaman, W. M., Shukri, F. R., & Adelin, N. M. (2017). Factors That Influence the Zakat Collection Funds: Case Study in Kuantan. *South East Asia Journal of Contemporary Business, Economics and Law, Vol. 13*.
- Amin, H. (2007). Extending TAM to SMS banking: analyzing the gender gap among students. *International Journal of Business and Society*, 8 (1).
- Aziz, M. (2015). Metode Istiabat Hukum Zakat Perspektif Yusuf Al Qardawi Dan Implikasinya Terhadap Pengembangan Objek Zakat Di Indonesia.
- Azman, A. S., Norzalina Zainudin, & Latifa Bibi Musafar Hameed. (2014). Keberkesanan Medium Maklumat Sebagai Perantara Terhadap Potensi Berzakat : Kajian Kes Golongan Muda (IPT). *Synergizing Knowledge on Management and Muamalah*.
- Bakar, N. B., & Hafiz Majdi Abdul Rashid. (2010). Motivations of Paying Zakat on Income: Evidence from Malaysia. *International Journal of Economics and Finance*.
- Bhatti, W. A., Hee, H. C., & Sundram, V. P. K. (2012). *A Guide for Beginners: Data Analysis Using Spss and Amos*. Kuala Lumpur: Pearson Malaysia.
- Bidin, Z. (2008). Faktor-faktor Penentu Niat Gelagat Kepatuhan Zakat Pendapatan Gaji.
- Chapra, M. U. (1979). *Objectives Of The Islamic Economic Order, The Islamic*.
- Coakes, S. (2013). *SPSS Version 20.0 for Windows: Analysis without anguish*. Australia: John Wiley & Sons Australia Ltd.
- Coakes, S., & Steed, L.G. (2003). *SPSS: analysis without anguish: version 11.0 for Windows*. Brisbane: Jacaranda Wiley.
- Ellany, E., & Lateff A. (2011). Faktor-Faktor Yang Mempengaruhi Pembayaran Zakat Pendapatan Di Malaysia. *Persidangan Ekonomi Malaysia Ke VI (PERKEM VI)*.
- Fallan, L. (1999). Gender, Exposure to Tax Knowledge and Attitudes Towards Taxation; An Experimental Approach Lars Fallan. *Journal of Business Ethics*, 18, 173–184.
- Gay, L. R., & Diehl, P. L. (1996). *Research Methods for Business and Management*. Singapore: Prentice Hall, c1996.
- Ghazali, A. (1988). *Zakat Satu Tinjauan*. IBS Buku Sdn Bhd.
- Gliner, J., Morgan, G.A, & Leech, N.L. (2009). *Research Method in Applied Setting: An Integrated Approach to Design and Analysis*. New York: Taylor & Francis Group, LLC.
- Gopi, & Ramayanah. (2007). Applicability of theory of planned behavior in predicting intention to trade online: Some evidence from a developing country. *International Journal of Emerging Markets*.
- Hair, J., Anderson, R.E., Tatham, R.L, & Black, W.C. (1998). *Multivariate Data Analysis, (5th Edition)*. Upper Saddle River. NJ: Prentice Hall.
- Hair, J., Black, W.C., Babin, B.J, Anderson, & Tatham, R.L. (2006). *Multivariate Data Analysis, 6th ed*. USA: Prentice Hall International.
- Hairulnizam Wahid, S. A. (2007). Kesedaran membayar zakat. *slāmiyyāt*.
- Haji-Othman, Y. (2017). Compliance Behavior of Income Zakat in Kedah: A moderating Effect Of Islamic religiosity.
- Hamid, A., & Nordin, N. (2001). A study on Islamic banking education and strategy for the new. *International Journal of Islamic Financial Services*, 2(4), pp.311.
- Hasan, A. H. (1988). Antara Zakat dan Cukai Pendapatan Satu Analisis Penyelarasan.
- Heikal, M., & Falahuddin. (2014). The Intention to Pay Zakat Commercial: An Application of Revised Theory of Planned Behavior. *Journal of Economics and Behavioral Studies, AMH International*, vol. 6(9), pages 727-734.
- Huda, N., Nova Rini, Yosi Mardoni, & Pumama Putra. (2012). The Analysis of Attitudes, Subjective Norms, and Behavioral Control on Muzakki's Intention to Pay Zakah. *International Journal of Business and Social Science*.
- Hidayati, A., & Achamad Tohirin. (2010). *Management of zakah: Centralized Vs decentralized approach, 7th International Conference*.
- Idris, K. M. (2002). Gelagat Kepatuhan Zakat Pendapatan Gaji Di Kalangan Kakitangan Awam Persekutuan Negeri Kedah.
- Idris, K. M., Zainol Bidin, & Ram Al Jaffri. (2012). Islamic Religiosity Measurement and Its Relationship with Business Income Zakat Compliance Behavior. *Jurnal Pengurusan*, 34, 3–10.
- Ismadi Badarudin, Arifin Saleh, Sy Ahbudin Senin, & Alias Aziz Deraman. (2004). Kajian aplikasi sistem dalam pelaksanaan zakat berkomputer di negeri Melaka.
- Jaafar, M. N., Amirul Aiff Muhamat, & Hardi Emrie Rosly. (2011). A Study on the Factors Attributes to Non Participation of Zakat Income Among the Muslim Community in Selangor. *2nd ICBER 2011*, 450–462.
- Jaffri, R. A. (2010). Gelagat Kepatuhan Zakat Perniagaan di Negeri Kedah Darul .
- Johari, F., Muhammad Ridhwan Ab. Aziz, & Ahmad Fahme Mohd Ali. (2014). A Review on Literature Of Zakat.
- Kamil Md. Idris, Zainol Bidin, & Ram Al Jaffri Saad. (2012). Islamic Religiosity and Its Relationship with Business Income Zakat Compliance Behavior. *Jurnal pengurusan*, 34, 3–10.
- Kamil, M. (2005). The role of intrinsic motivational factors on compliance behaviour of zakat on employmThe role of intrinsic motivational factors on compliance behaviour of zakat on employmentent . in *Isu-isu Kontemporari Zakat di Malaysia. (1st ed.)*. Melaka: UiTM pp. 137-170. .
- Khamis, M. R., Ariffin Md Salleh, & Abd Samad Naw. (2011). Compliance Behavior of Business Zakat Payment in Malaysia: A. In *8th International Conference on Islamic Economics and Finance* (pp. 1–17).
- Khamis, M. R., Ariffin Md Salleh, & Abd Samad Naw. (2011). Compliance Behavior of Business Zakat Payment in Malaysia: A Theoretical Economic Exposition. *8th International Conference on Islamic Economics and Finance*.
- Khamis, M. R., Rohani Mohd, Ariffin Md Salleh, & Abdol Samad Naw. (2014). Do Religious Practices Influence Compliance Behaviour of Business Zakat among SMEs? *Journal of Emerging Economies and Islamic Research*.
- Lateff, E. E., & Mohd Rizal Palil. (2011). Faktor-Faktor Yang Mempengaruhi Pembayaran Zakat Pendapatan. *PROSIDING PERKEM VI, JILID 1 (2011) 148 – 159*.
- Mannan, M. A. (1986). *Islamic Economics: Theory and Practices*, Cambridge: Hodder and Stroughton.
- Mastura, F., Noor Azman Ali, & Zainol Bidin. (2015). Factors Influencing Zakat Compliance Behavior on Saving. *International Journal of Business and Sosial Research*.

- Michell, P., & Al-Mossawi, M. (1999). Religious commitment related to message contentiousness". *International Journal of Advertising*, Vol. 18 No. 4, pp. 427-443.
- Mishra, D., Ibrahim Akman, & Alok Mishra. (2014). Theory of Reasoned Action application for Green Information Technology acceptance. *Published in Computers in Human Behavior*.
- Mohd. Safi, M. (2006). Zakat perniagaan: Cabaran pelaksanaan di Malaysia. Dalam I. Abdul-Ghaffar & M. T. Hailani (Eds.), *Zakat: Pensyaraitan, Perekonomian dan Perundangan* (pp. 174-197).
- Mohsin, M. I. (2015). Potential of Zakat in eliminating riba and eradicating poverty in Muslim countries {Case Study: Salary deduction scheme of Malaysia}. *International Journal of Islamic Management and Business*.
- Natrah, S. (2014). Tax Knowledge, Tax Complexity and Tax Compliance: Taxpayers' View. *Social and Behavioral Sciences*, 109(1), 1069-1075.
- Nor, A. M., Hairunnizam Wahid, & Nor Ghani Md Nor. (2004). Kesedaran Membayar Zakat Pendapatan di kalangan Kakitangan Profesional Universiti Kebangsaan Malaysia. *Islamiyyat T 26(2)(2004): 59 - 67*.
- Osman, A., Yusuf Haji-Othman, Rana S M Sohe, & Mohammad Solaiman. (2016). Effectiveness of Promotional Tools to Influence the Purchase Decisions of Unsought Products: A study on life insurance. *The Social Sciences*, 11(2), 87 - 92.
- Othman, Y., & Wan Nazjmi Mohamed Fisol. (2017). Islamic Religiosity, Attitude and Moral Obligation on Intention of Income Zakat Compliance: Evidence from Public Educators in Kedah. *International Journal of Academic Research in Business and Social Sciences*.
- Palil, M. R. (2010). Tax Knowledge and Tax Compliance Determinants in Self-Assessment System in Malaysia.
- Qardawi, Y. A. (1998). *Peranan nilai dan akhlak dalam ekonomi Islam*. Angkatan Belia Islam Malaysia (ABIM).
- Qardawi, Y. A. (1999). *The Lawful and The Prohibited in Islam*. American Trust Publications.
- Rahman, A. A., Amiruddin Mohd Sobali, & Syed Mohd Najib Syed Omar. (2012). *Keengganan Membayar Zakat: Menurut Perspektif Syarak dan Perundangan Islam Di Malaysia*. Universiti Sains Islam Malaysia.
- Rahman, M. (2003). *Zakat Calculation: Primarily Based on Fiqh uz Zakat by Yusuf al Qaradawi*. Islamic Foundation (2003).
- Ramayah, T., & Norazah Mohd Suki. (2006). Intension to Use Mobile PC Among MBA Students: Implication for Technology Integrati on in the Learning Curriculum For Technology.
- Rammal, H., & Zurbruegg, R. (2007). wareness of Islamic banking products among Muslims: The case of Australia. *Journal of Financial Services Marketing*, 12(1), pp.65-74.
- Rehman, M. A., & Muhammad Shahbaz. (2010). The Relationship Between Religiosity and New Product Adoption. *Journal of Islamic Marketing*, 63-69.
- Saad, R. A., & Roszaini Haniffa. (2014). Determinants of Zakah (Islamic tax) Compliance Behavior. *Journal of Islamic Accounting and Business Research*.
- Sanusi, N. A., Norazlina Abd. Wahab, & Nor Fadzlin Mohammad Bahar. (2004). Gelagat Kepatuhan Pembayaran Zakat Pendapatan : Kajian Kes UUM.
- Sapingi, R., Noormala Ahmad, & Marziana Mohamad. (2011). A Study On Zakah Of Employment Income: Factors That Influence Academics' Intention To Pay Zakah. In *2nd International Conference on Business and Economic Research*, (pp. 2492-2507).
- Sekaran, U. (1992). *Research Methods for Business: A skill-building approach*. United Kingdom: John Wiley & Sons Ltd.
- Sekaran, U. (2003). *Research Methods for Business: A Skill-building Approach*. John Wiley & Sons.
- Sekaran, U., & Bougie, R. (2013). *Research Methods for Business: A skill building approach sixth edition*. United Kingdom: John Wiley & Sons Ltd.
- Shaari, N. A., Nur'adhilah Abu Hasan, Ramesh Kumar Moona Haji Mohamed, & Mior Ahmad Jafri Md Sabri. (2013). Financial Literacy: A Study Among The University Students. *Interdisciplinary Jourizal of Contemporary Research In Business*. 5(2), pp. 279-299.
- Shukor, S. A., & Jamal, A. (2013). Developing Scales for Measuring Religiosity in the Context of Consumer Research. *Middle-East Journal of Scientific Research 13 (Research in Contemporary Islamic Finance and Wealth Management)*, pp.69-74.
- Siddiqi, S. A. (1968). *Public Finance in Islam*. S. H. Muhammad Ashraf, Lahore, Pakistan. .
- Syahrullah, & Maria Ulfah. (2016). Response of Indonesian Academicians Toward Factors Influencing the Payment of Zakat on Employment Income.
- Taib, F. M., T. Ramayah, & Dzuljastri Abdul Razak. (2008). Factors Influencing Intention to use Diminishing Partnership Home Financing. *International Journal of Islamic and Middle Eastern Finance and Management*.
- Tajuddin, T. S., Aza Shahnaz Azman, & Noraini Shamsuddin. (2016). Zakah Compliance Behaviour On Income Among Muslim Youth In Klang Valley. *Shariah Journal*, Vol. 24, No. 3 (2016) 445-464.
- Wahid, H., & Radiah Abdul Kader. (2010). 'Localization of Malaysian zakat distribution: perception of amil and zakat 'Localization of Malaysian Zakat Distribution: Perception of Amil and zakat. *International Conference - The Tawhidi Epistemology: Zakat and Waqf Economy*.
- Wahid, H., & Sanep Ahmad. (2013). Keberkesanan dan Kesesuaian Medium Promosi Agihan Zakat: Kajian Kes di Negeri Selangor. *PERKIM VIII, JILID 1*, 28-37.
- Wahid, H., & Sanep Ahmad. (2013). Keberkesanan dan Kesesuaian Medium Promosi Agihan Zakat: Kajian Kes di Negeri Selangor. *PERKIM VIII, JILID 1*, 28-37.
- Wahid, H., Mohd Ali Mohd Noor, & Sanep Ahmad. (2005). Kesedaran Membayar Zakat: Apakah Faktor Penentunya? *IJMS*, 12(2), 171-189.
- Wahid, H., Sanep Ahmad, & Radiah Abdul Kader. (2009). Pengagihan Zakat oleh Institusi Zakat di Malaysia: Mengapa Masyarakat Islam Tidak Berpuashati? *Shariah Journal*, Vol. 17, No. 1 (2009) 89-112.
- Yusof, M. I. (2010). Pengurusan Zakat Di Negeri Selangor: Mengorak Langkah Meneraju Perubahan. *International Islamic Development Management Conference (IDMAC 2010)*.
- Zainol, B., & Faridahwati, M. S. (2013). Using Theory of Reasoned Action to Explain Taxpayer Intention to Comply with Goods and Services Tax (GST). *Middle-East Journal of Scientific Research*, 17(3), 387-394.
- Zainuddin, Jahyd, N., & Ramayah, T. (2004). Perception of Islamic Banking: Does It Differ among Users and Non Users.
- Zickmund, W. G. (2003). *Business Research Methods*. Ohio: Thompson.
- Zulkifli, D., & Sanep, A. (2010). Kesan Perundangan Zakat Ke atas Kepatuhan Bayaran Zakat: Ke Arah Strategi Berkesan Program Pengurusan Kutipan Zakat. *The 4th ISDEV International Islamic Development Management Conference (IDMAC 2010)*.

COVID-19: REINFORCING THE IMPACT OF ISLAMIC BANKING THROUGH VALUE-BASED INTERMEDIATION

Shamsuddeen Muhammad Ahmad^a, Nur Farhah Mahadi^b & Nur Razinah Mohd Zain^c

^aUniversity Malaysia Perlis & Kano State Polytechnic, Nigeria

^{b, c}International Islamic University, Malaysia

Abstract

The novel COVID-19 pandemic has caused an unprecedented human crisis around the globe. The necessary actions implemented to contain the virus have sparked both economic and social downturn. It shows the fragility and unpreparedness of the economy to face such a pandemic. Significant weakening of economic conditions has escalated the pressure on households, businesses and financial markets. However, Bank Negara Malaysia has taken a new initiative by introducing Value-Based Intermediation (VBI). The approach of VBI opens a new pragmatic dimension for Islamic banks in providing impactful and beneficial services to the public at large. This paper investigates the approach of VBI and its proposed implementation from Shari'ah perspective. Depending on qualitative investigation, this paper also explores the practices of Islamic banks in applying VBI through Islamic social finance and its impacts. It is found that VBI facilitates Islamic banks to provide impactful services to their customers and other innovative strategies based on Islamic social finance.

Keywords: Covid-19, Islamic Banking, Value-Based Intermediation

1.0 INTRODUCTION

The COVID-19 pandemic represents the biggest test of the post-crisis financial system to date. The pandemic constitutes an unprecedented global macro-economic shock, pushing the global economy into a recession of uncertain magnitude and duration (FSB, 2020). The global financial system faces the dual challenge to sustain the flow of credit amidst declining growth and to manage heightened risks. Governments all over the globe are in the process of formulating and implementing appropriate policies to continue economic activities amidst this turmoil (Shamsuddeen et al., 2020). Besides the Government (policy makers and regulators), financial institutions, sitting at the heart of the economy, have a crucial responsibility in dealing with the adverse effects of COVID-19.

Traditionally, banks and other financial institutions were considered as a mere intermediary between the lender and the borrower. Social considerations were barely present in the business portfolios of financial institutions until the introduction of 'Corporate Social Responsibility' (CSR), Environmental Social Governance (ESG), and impactful investment. Like many other financial institutions, Islamic Financial Institutions or IFIs have become a major player in the financial markets of many countries (Shamsuddeen et al., 2020). In Malaysia, IFIs have already provided similar incentives/relaxations that conventional financial institutions provided for the public. But what additional value or incentives can IFIs exclusively offer during this trying period? This answer becomes more relevant for nations where Islamic finance is endemic, like Malaysia where the size of the Islamic finance industry exceeds 30% of total finance assets.

Value-based intermediation (VBI) aims to deliver the intended outcomes of *Shar'iah* (Islamic law) through practices, conduct and offerings that generate positive and sustainable impact to the economy, community and environment, consistent with the shareholders' sustainable returns and long-term interests. Current initiatives primarily focus on ensuring that the product structures, features and operational aspects of financial transactions (including services) comply with *Shar'iah* requirements as specified in the regulatory framework. It is essential that greater emphasis should be given to consider the wider impact of the financial activities (BNM Strategy Paper, 2018). It seems that the pandemic has presented an opportune moment for IFIs to exhibit their unique socio-economic principles and perform their value-based responsibilities. This paper examines the how Islamic banks can strengthen their impact through value-based intermediation amid Covid-19 pandemic.

The rest of the paper is organized as follows. The next section discusses the concept of value-based intermediation, value-based intermediation from Islamic perspective and VBI in the practice of Islamic Banks. Section 3 describes the underpinning thrust of the VBI during covid-19, while in section 4 concludes the paper.

2.0 LITERATURE REVIEW

2.1 Value-based Intermediation

Value-Based Intermediation (VBI) is defined as “an intermediation function that aims to deliver the intended outcomes of *Shari`ah* through practices, conduct, and offerings that generate positive and sustainable impact to the economy, community and environment, consistent with the shareholders’ sustainable returns and long-term interests” (BNM Strategy paper, 2017). The value-based intermediation or VBI was first introduced in Malaysia in July 2017. This was done through the issuance of a strategy paper by the Central Bank of Malaysia titled the “Value-based Intermediation: Strengthening the Roles and Impact of Islamic Finance”. The introduction of VBI receives positive feedback from the industry players, especially *Shari`ah* scholars. By having VBI as an approach to sustainability, the IFSI is shaped to be stronger especially in resilience towards economic crisis. Furthermore, Malaysia is also attempting to contextualize VBI into a pragmatic practice in the financial services as offered by the IFSI.

According to BNM, IBIs must ensure that their strategy manifests the four underpinning VBI principles (BNM Strategy Paper, 2017):

- 1) Entrepreneurial mindset – the focus of this area is premised on greater involvement in facilitating entrepreneurial activities through holistic offerings by IBIs, which includes financing and proactive support, i.e. advisory, market infrastructure and business network.
- 2) Community empowerment – it is aimed to empower communities through the provision of financial solutions that create a positive impact.
- 3) Good self-governance – this thrust concerns inculcating organisational discipline (self-restraint) and ensuring the meaningful participation of all stakeholders in the governance framework.
- 4) Best conduct – the focus of these principles is to adopt practices that improve IBIs’ offerings, processes, and treatments toward their stakeholders (including IBIs’ customers and employees).

The Islamic banking system is based on trust and community. A common objection is that this is only possible in small communities capable of sustaining personal relationships. To underpin such a development Zaman (2008) argues that a Dar-ul-Amanah is needed to preserve the value of deposits which would then be used for socially profitable objects. The potential to use Islamic motivation to create new types of institutions that conform to the Islamic spirit is illustrated by the Tabung Haji in Malaysia which helps Muslims to perform the Hajj and mobilizes savings for this purpose (IRTI, 1995).

2.2 Value-Based Intermediation from Islamic Perspective

It is believed that VBI is an attempt to promote a more holistic view of *Shari`ah* that is beyond *Shari`ah*-compliance in the business activities of IBIs. According to BNM (2017), wealth preservation forms the core of the *Shari`ah* objectives in financial transactions of IBIs. However, VBI’s approach for wealth preservation goes beyond its literal meaning since it includes encouragement to generate, accumulate, and distribute the wealth in a just and fair manner (BNM Strategy Paper, 2017). This means that VBI has come to serve IBIs as a great place to contribute to social needs. It also emphasizes on developing ethical values for IBIs within the framework of *Maqāsid al-Shari`ah*.

Generally, any approach which is not contradictory to *Shari`ah* is acceptable to be practiced unless there is a clear prohibition to such an approach. In facing the reality of financial services and market, an innovative approach can be considered as a necessity especially when it is to enhance and strengthen the principles of *Shari`ah* in IFSI while facing the modern world. This is allowed by following the Islamic legal maxim of *al-aslu fi al-ashyā’ al-ibāḥah* that means the original of things is permissibility. Although VBI is permissible based on the said Islamic legal maxim, it is not wrong to take careful consideration in analyzing VBI. In analyzing the VBI from an Islamic perspective, it is important to examine the principles of *Shari`ah* that relevant to it. In essence, VBI is derived from the principles of *Shari`ah*. The end outcomes of VBI must be consistent with the holistic objectives of *Shari`ah* or *Maqāsid al-Shari`ah*. This can be traced from the strategy paper of VBI as produced by the Central Bank of Malaysia.

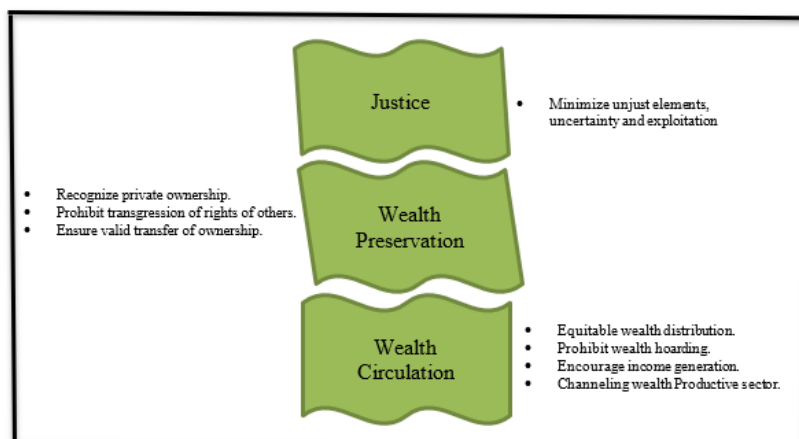

Figure 1: Intended Outcome of *Shari'ah*
Source: Bank Negara Malaysia, 2018

2.3 VBI in the Practice of Islamic Banks

Although VBI is emphasized towards IFSI, the center focus of such VBI practices are derived mainly from the Islamic banks in Malaysia. Since VBI's introduction in 2017, many Islamic banks are actively participated and make efforts to reach the recommendations as provided by the Central Bank of Malaysia. Bank Islam Malaysia Berhad (BIMB) is among the first Islamic banks that make such efforts towards VBI. They produced their own report titled Sustainability Report since 2016. Their approach towards sustainability is by aligning themselves with their goal of becoming a responsible financial entity in doing their financial services operations. As guarded under the principles of *Shari'ah*, BIMB utilized the Islamic social finance instrument of *sadaqah* in achieving VBI.

Another practice of VBI can also be traced from the initiative taken by Agrobank (M) Berhad. Recently, the said bank in collaboration with BERNAS launched an initiative to improve the productivity of paddy and farmers' standards of living. They provided at least a working capital that worth RM50 million to farmers. BERNAS provided free technical advice and consultation to those farmers. They also introduced *tawaruq* based financing facility as financial assistance to farmers with their Paddy-i-Tawaruq product. AmBank Islamic Berhad is another active Islamic financial institution that gives a focus to VBI. The said bank places their VBI initiative towards two main pillars of VBI, namely (i) the financial inclusion, and (ii) environmentally and socially responsible financing. According to the Chief Executive Officer of AmBank Islamic Bhd., Mr. Eghwan Mokhzanee Muhammad, the main focus of the said bank is to have active engagements with small and medium enterprises (SMEs) in Malaysia.

These practices of VBI from the selected Islamic banks indicate the positive acceptance of VBI as introduced by the Central Bank of Malaysia. For certain Islamic banks, their initiatives towards sustainability and achieving *Maqāsid al-Shari'ah* are already carried out even before the introduction of VBI to IFSI in Malaysia.

3.0 THE UNDERPINNING THRUSTS OF VBI IN THE CONTEXT OF COVID-19

COVID-19 has brought a significant shift in the economic condition of the people, and substantial changes in consumption and expenditure patterns. Previous studies have shown that the self-employed group is most vulnerable during, and potentially after the severe economic shock caused by the pandemic (Abdul Hamid, Mohammed & Shamsudheen, 2020). Private sector employees are also not adequately prepared, implying that the impact of financially fragile sectors requires more attention from government. It also signifies that savings habits may require additional reinforcement, with incentives and financial literacy programs for more effective financial planning.

Whilst some countries have been successful in containing the spread of the pandemic, new information on the nature of the virus is consistently released. Therefore, the overall impact is still unpredictable although lockdown efforts have seemed to thwart infection rates substantially (Abdul Hamid, Mohammed & Shamsudheen, 2020). However, economic woes are expected to be felt for some time. More so, In Islamic teachings, every Muslim is expected to embrace the sense of social responsibility towards the community. In the Islamic economic system, this principle allows people to earn their living in a fair and profitable way without exploitation of others so that the entire society may benefit from it (Lewis, 2006).

This principle has been embedded in the thrust of ‘Community Empowerment’ whereby it is a thrust that is created to empower society through the establishment of financial solutions that create a positive impact among them. As a result, an IBI can play a significant role in creating socially sustainable economic impacts for the communities with a balanced consideration between commercial and social aspects (Hassan & Nor, 2019). That can be achieved through the development, funding, and implementation of effective solutions for issues faced by the communities, which aim to create a positive impact on the communities and new business opportunities for IBIs. An example includes the integration of *waqf* and *Īadaqah* within Islamic financial transactions (BNM Strategy Paper, 2017). This integration could also be executed effectively during this period. The unique feature of these funds is unilateral payment, and it reduces the financial difficulties of beneficiaries as they are not required to pay back for the monetary benefit received during the period.



Figure 2: Underpinning thrusts of VBI in the context of Covid-19
Source: INCEIF Covid-19 Economic Outlook Series, 2020

As shown in the figure 2, one of the important thrusts of VBI is solving common issues faced by communities. As COVID-19 has adversely impacted communities in several ways, IFIs could empower communities through provision of financial solutions that create positive impact. In the context of social obligation, those who are capable have the responsibility to assist those who are not, via effective distribution of wealth. IFIs could play a significant role in creating socio-economic impact for the communities by being a responsible intermediary. Balanced consideration between commercial and social aspects should provide a central lynchpin for IFIs in navigating its strategic decisions, thus encouraging the practice of giving back to society, beyond corporate social responsibility activities.

4.0 CONCLUSION

Value based intermediation is a long journey that requires significant transformation of mindset among key stakeholders. Strong and visionary leadership is central to this paradigm shift, specifically in driving changes in the current culture, people and overall ecosystem. Islamic finance advocates empathy and compassion as part of the fundamental Islamic principles. As an expression of this, Islamic banks can collaborate on a crowdfunding platform to create a special fund with zero profit for a predetermined short term, to cushion the impact of their customers, particularly, the micro and SME sectors. Islamic banks can also crowdfund to assist in creating an emergency food bank, protective medical supplies, delivering essentials to the affected people and to provide information and resources on COVID-19. The sector can be a role model by contributing to the positive sentiment of their employees that are forced to work from home without proper support in childcare, IT equipment and internet connectivity, house and family responsibilities and financial challenges by rolling out systematic and clear remote work plans. This mutually beneficial arrangement will restore employee productivity and boost morale.

REFERENCES

- Abdul Hamid, B. Mohammed, Z. and Shamsudheen, S. V. (2020). COVID-19: The Pandemic Disruptor and the new Economic Norm. *Research Management Center, INCEIF*
- Bank Negara Malaysia: Value-based Intermediation: Strengthening the Roles and Impact of Islamic Finance. Strategy Paper, issued 12th March, 2017
- Financial Stability Board (FSB) (2020). COVID-19 pandemic: Financial stability implications and policy measures taken 15 April, 2020
- Hassan, R. B. and Nor, F. M. (2019). Value-Based Intermediation: An Analysis from the Perspective of *Shari'ah* and Its Objectives. *International Journal of Fiqh and Usul al-Fiqh Studies*. Volume 3, Issue 1, 1440/2019
- Islamic Research and Training Institute (1995)
- Lewis, M. K. (2006). *Accountability and Islam*. Fourth International Conference on Accounting and Finance in Transition, 1–16.
- Shamsudheen, S. B. et al., (2020). Covid-19: High Time for Islamic Banks to Show They are Indeed Value-Based Intermediaries. Covid-19 Economic Outlook Series. *Research Management Centre, INCEIF*. April 2020, Issue 4
- Zaman A. (2008). Islamic Economics: A Survey of the Literature, *Munich Personal RePEc Archive*

BUSINESS STRATEGY IMPACT IN CUSTOMER RELATIONSHIP MANAGEMENT PERFORMANCE CHARACTERISTIC AMONG SME'S TRANSPORT SERVICE

Muhamad Fairos Mohamad Shah

FS Management and Academy Pulau Pinang

Abstract

Small and medium enterprises (SMEs) have been competing for survival in the business arena among established organizations. Competitive logistic service business today requires a unique and lasting brand experience to capture customer loyalty. Despite that, earning customer trust is vital to ensure ongoing revenue and profit for business sustainability. Objective of this study is to investigate relationship customer satisfaction and loyalty in delivery industries. Furthermore this study to describe the characteristic of customer and to determine the degree to which marketing variables associated and significant relationship. This study was conducted at Johor Bharu, Pulau Pinang and Selangor. The method of this study are applied research and respondent is individual customer from a logistic company. In addition this study total respondent answered questionnaires about three hundred and ninety one customer. According to finding, the result showed that survey by questionnaire on likert scale is significant to the study. Lastly this study also conducted by SEM analysis. The dimensions for customer relationship management performance factors are business process strategy. Measurement for business process strategy on this study about the Islamic business ethics of customer toward the initiative taken by Logistic service provider on customer value creation, user respect and user consent. However the emergence of new entrepreneurship initiatives especially small enterprises to create innovative ideas can have an impact on the growth and prosperity of the organization and subsequently transport in SMEs. Thus, the growth and establishment of small enterprises can make a unique contribution to entrepreneurship in every economy of the world. Through this customer relationship management studies, entrepreneurship can create innovations that provide new businesses, products, technologies, markets, good quality and more to an economy that can improve gross domestic product and the standard of living of the people.

Keyword: Customer Relationship Management, Business process strategy, SEM analysis, SME's.

1.0 INTRODUCTION

Islamic Business Ethics it is a simple entrepreneurship in a technology intensive context. It is a process of merging technology process and entrepreneurial talent and skills.

Entrepreneurship is a way of thinking and acting that is opportunity obsessed, holistic approach and leadership balanced for the purpose of wealth creation. Searches for change, responds to it, and exploits it as an opportunity. On top of that innovation is the specific tool of entrepreneurs, the means by which they exploits change as an opportunity for a different business or a different service. Entrepreneurship pursuit of opportunity without regard to the resources currently under one's control.

Nowadays, we cannot avoid the muamalat business ethics in our daily life. According to Shah et al., (2017) the using of technology in our life brings more advantages especially in business management. As an entrepreneur to gain or generate more profit for our business every day and with the proper use of technology, customers can get the products or services that we provide to them all around the world without need to meet them face to face. By using the right platform for the business, it will help the business to know what is the right opportunity for the entrepreneur to grab and provide products, services by make it unique as well as memorable to the customers (Shah et al., 2018). The customer relationship function in company represents the front office functions that interact with customers. These are the business processes that allow company to sell products and services to customers, more over communicate with customers with regards marketing and dealing with the after sales service requirements of customers. Each interaction with the customer is recorded and stored within the CRM software where it can be retrieved by other employees if needed to review.

2.0 LITERATURE REVIEW

Customer Relationship Management is an Islamic business ethic. It helps the company to collect and preserve customer details through continuous survey of information about products and services offered to the customer. In this way, companies can customize the suitable product and service preferred by the customer. Effective CRM has become a critical challenge in business competition and marketing and economic advancement of a country (Shah et al., 2016). Firstly is customer loyalty elements in developing integrated customer relationship management strategy. In addition Shah et al., (2019) state that business opportunity is a customer's needs and want that can potentially be meeting by a new business. The source of business opportunity based on problem that customers had in daily life, there are new products or services that discover by an request, from an existing products and services that the entrepreneur wants to improve, or turn some experience or uncommon knowledge into a product or services that benefits others. Then, they need to do some market survey in order to know what the customers' needs and want and how they could solve the problems and make the customers remember the products or services that they used. Customers' satisfaction is an important thing to the business in order to generate the profit and accelerate the growth of the business.

According to Shah et al., (2018), (2019) by utilizing customer value creation, user respect and user consent it is known that entrepreneur are saving the time and distance through cost of marketing and shipping. That a business can be open anytime anywhere, making purchases from different region easier and more convenient. The electronic devices and social network (Blogger, Facebook, twitter, etc) are able to shorten the lead time business spend on receiving and delivering goods or services, creating an instant competitive advantage in the small business. It means that the business process become much simple and easier to the both of suppliers and consumers (Brdiger EK and Wood A 2017). Then, it can maximizing revenue and profits. This is turn increases productivity which ultimately gives rise to profits that means better pay and less strenuous working conditions. The SME's entrepreneur will optimize the resources by decreasing the raw material cost but gaining profits as many as possible through the utilization of technopreneurship toward their business. This was stated by Shah et al., (2020) based on business opportunities, management can increase profits as they can take advantage of opportunities to increase their profits. This is because not everyone will get the same chance. Often the chances are only attracted by some people. Hence, it is the golden opportunity that traders need to take to profit as much as possible. To increase the customers based on existing business opportunities, they must work hard to attract customers. As you know, the newly opened business opportunity has many opportunities to increase existing customers. They should use as many opportunities as possible to increase the number of customers besides expanding their business. And if they already have customers, the way to further increase the number of customers is to show customer reviews of their products to the public. This is also one way to increase the number of customers to the business.

2.1 Customer Relationship Management

Customer relationship management tools include software and browser-based applications that collect and organize information about customers. For instance, as part of their CRM strategy, a business might use a database of customer information to help construct a customer satisfaction survey or decide which new product their customers might be interested in.

Based on innovation, the way to increase sales profits is to reduce the existing cost of the product that has been generated. There are many ways in which traders should think to be something more exciting in the future they must reduce the cost of production of each unit of product (Dehghanpouri et al., 2020), (Shah et al., 2019). This way they can further enhance existing profits.

Based on the concept of product innovation, how to increase customers is to advertise about the innovations that have been made to the product and service. They can advertise in altitude or press. Advertising is one of the most effective ways to promote a product in a short time. According to Shah et al., (2016) the more advertising SME's products are running, the more customers will be aware of the existence and activation of our products and now can certainly attract customers to buy and use our products.

To increase sales profits, as a businessman have to do a product maker. It can be very useful. Buying a low and high sales is definitely the best model for business profits, and if possible to mark more products and maintain a steady flow of business, it will benefit the unfinished profit center. With the presence of a product marker, it can show how far we have the advantage that we can add more strategies to increase existing sales to increase profits. At the same time Shah et al., (2020) added that the best way businesses can get more customers is earning revenue from customers who already know, like and trust your brand more effectively than spending money to get new customers. If you provide customers with superior experience, they will want to do business with you in the future

and will likely send instructions in your way. Almost every business can implement a customer reference program by offering current customer products or services to refer to new customers or customers. Therefore this is how the business can get more customers at the same time, they can gain profits in the business.

Last but not least this interpretation contrast with that of Abhishek et al.,(2018) who argue that business process strategy is a customer's needs and wants that can potentially be meeting by a new business. A business opportunity involves the sale or lease of any product, service, equipment and so on that will enable the purchaser-licensee to begin a business. The source of business opportunity based on problem that customers had in daily life, there are new products and services that discover by an accident, from an existing products and services that the entrepreneur wants to improve into a products and services that can give benefits to others.

2.2 Business Process Strategy

Customer relationship management processes that help form individualized relationships with customers (to improve customer satisfaction) and provide the highest level of customer service to the most profitable customers. Innovation in business process strategy is the action or process of innovating (Edenat, M.A.2018). Referring to Shah et al.,(2019) entrepreneur sells the products and services based on customer satisfaction. They use the correct platform to promote the products and services to make sure the customers know about it and buy the products and services. In the same time, the customer can continuous use the products and services, it will generate our profit (Islam et al.,2017). Technopreneurship are very important to improve sales and customer because with the technology can upgrade the volume of product and service than use the traditional way (Shah et al.,2020).Hence that technology may improve the the quality and quantity of products.

In addition, business process in innovation can generate more profit are the systematic act of turning "something" (product, idea, information, technology, etc.) into a resource that is high value to its target market. The customers do not buy idea, they buy products or services and innovation can necessity is the mother of all invention. Moreover,Shah et al.,(2020),Wahab et al.,(2019) reveal that innovation is at the heart of any growing economy, especially in those where standard practices and existing business models have become obsolete. Redundancy in business practices can lead to financial stagnancy. Entrepreneurship is key to innovating at the individual business level as well as inspiring overall business-sector growth. Successful entrepreneurship requires a focus on creativity, integrating innovation and strategic business practices.

2.3 Customer Relationship Management And Business Process Strategy

Customer relationship management processes that help identify and target their best customers, generate quality sales leads, and plan and implement marketing campaigns with clear goals and objectives. Furthermore technopreneurs are entrepreneurs who are into the core businesses involving technology-based industries. This is supported by Tharikh et al.,(2020) they make use of business process in technology to come out with new or innovative products through a process of commercialization. Hence to generate more profit (sale / customer) in accelerate their business growth technopreneur continuously go through an organic process of continual improvement and always try to redefine the dynamic digital economy a technopreneur is an entrepreneur who is technology savvy, creative, innovation, dynamic, dares to be different and take the unexplored path, and very passionate about their work. They take failure as a learning experience, a stimulator to look things differently and stride for next challenge. Last but not least SME's providing value to customers by harmonizing in-depth materials know-how gained during the development of original product categories that straddle organic and inorganic chemicals and a wide range of technologies developed during the process of making more advanced products.

3.0 OBJECTIVES OF THE STUDY

The objectives of this study are as follow:

1. To investigate the impact of business process strategy in customer relationship management of SME's logistic provider.

4.0 METHODOLOGY

This research is empirical test as well as correlational research in nature. According to Hair et al (2010) for applied research identify by questionnaire. Hence questionnaire survey was carried out for this research and distributed to the individual respondents that consume logistic service provider. In this study likert scale questionnaire were apply for customer to fill in form. Population is a target groups is the customer on the logistic service provider. The target population of this study were three hundred and ninety one respondent from Selangor, Johor Bharu and Pulau Pinang on A, B, and C organization company.

4.1 Theoretical Background for the Models

Customer relationship management is a broadly recognized widely-implemented strategy for managing a company's interactions with customers, clients and sales prospects. It involves using technology to organize, automate, and synchronize business processes-principally sales activities, but also those for marketing, customer service, and technical support.

Business process strategy is the application of scientific knowledge for practical purposes, especially in industry and the development of process and output from scientific knowledge that customer relationship management organization. Business process strategy come into existing when we use the known earlier. This can be realized when an logistic service provider appoints a local company as the business process strategy for a particular area. So that, Chen and Popovich (2003) proposed the perfect underneath to present and support the impression of numerous authors on the significant of process strategy in realizing Customer Relationship Management Performance in the organization.

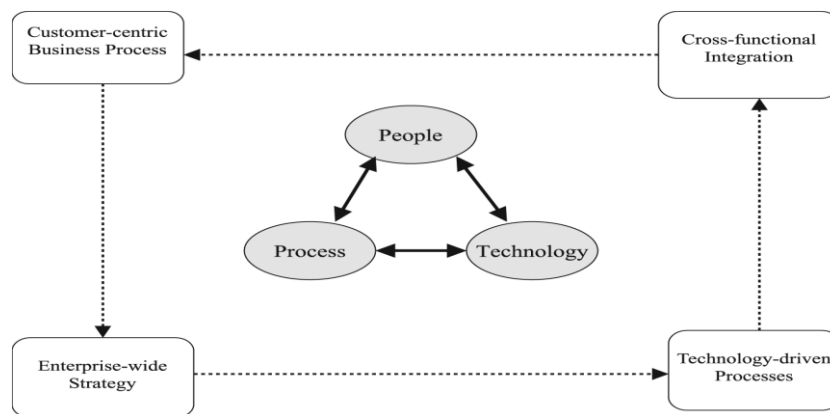

Figure 1: A CRM implementation model Chen and Popovich, 2003

4.2 Hypotheses Development

For this study, prototypical proposed that present research a business process strategy as the determination of Customer Relationship Management models for SMEs logistic in Malaysia. The absolute models projected are as follows.

4.3 Theoretical Framework

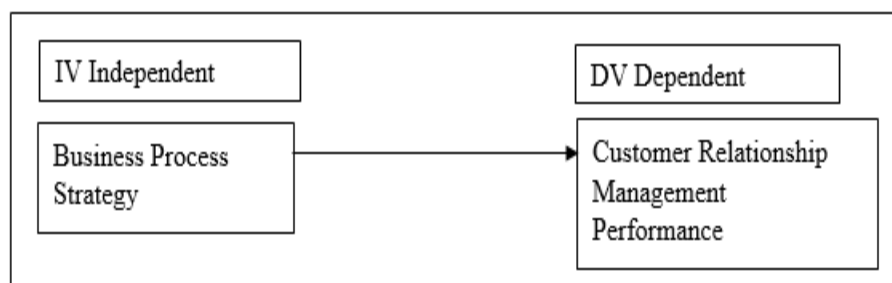

Figure 2: Theoretical Framework

In term of this study Wahab et al.,(2017),Soh et al.,(2017),Shah et al.,(2019),Shah,et al.,(2018),Shah et al., (2017) and Shah et al., (2016) at past research was investigated the character of provider value in business process strategy. Around is a positive significant relationship between business process strategy and customer relationship management. Hence, we hypothesized that:

4.4 Hypothesis

There is a significant relationship between business process strategy factor and Customer Relationship Management.

5.0 RESULT

The SEM model and relevant data are shown in Exhibits Table 3. The model fit parameters were similar to previous SEM analyses. These were considered acceptable for exploratory research focused on scale development (Hair et al., 2010., Beauducel, A. and Wittman, W. 2005). Analysis of the data was using SEM analysis which is previously tested for validity and reliability. Results of the examination of goodness of fit for overall model and was in accordance with the analysis result of SEM, in order to determine whether the hypothetical model is supported by empirical data, This section gifts the particulars of data analysis to assess measurement model and structural model concurrently by using SEM analysis. Moreover measurement instrument are evaluated via CFA dimensionality, reliability and validity of model where indicators are measured by multiple items (D. Gefen et al., 2000). (Crockett 2012). In this scenario given in Table 1 as such extended analysis of SEM independent variable model. One clarification for the illogical finding there is relationship between business process strategy and customer relationship management was the option of a suppressor effect due to interactive effects of multicollinearity in the SEM analysis. Thus, partial model independent variable is demonstrated and Hypothesis H3 is accepted. Nunnally (1994) suggest that all of the variables in the model estimated to fulfill the criteria of discriminant validity. Then it can be concluded that all of the variables have a good reliability (Sekaran, U. and Bougie, R. 2013). Below is analysis basic model for regression weight and standard regression weight business process strategy.

5.1 Basic Model

			Estimate	S.E.	C.R.	P
CRMP	<---	BPS	1			
bps2	<---	BPS	1			
bps1	<---	BPS	1.265	0.101	12.48	***
bps3	<---	BPS	1.414	0.103	13.675	***
bps4	<---	BPS	1.327	0.099	13.392	***
bps5	<---	BPS	1.147	0.092	12.425	***
bps6	<---	BPS	1.247	0.097	12.814	***
bps7	<---	BPS	1.132	0.095	11.966	***
bps8	<---	BPS	1.097	0.089	12.362	***

Table 1: Regression Weights

			Estimate
bps2	<---	BPS	0.654
bps1	<---	BPS	0.68
bps3	<---	BPS	0.75
bps4	<---	BPS	0.733
bps5	<---	BPS	0.677
bps6	<---	BPS	0.7
bps7	<---	BPS	0.651
bps8	<---	BPS	0.673

Table 2: Standardized Regression Weights

Based on the results, above are providing added predictive validation for the relationship between business process strategy and customer relationship management performance. As discussed in the theoretical framework, business process strategy is viewed as integral to organization performance. The finding showed that the customer perception of customer relationship management in logistic service provider result are actually moderately positive but further improvement are required to improve customer awareness and understanding of CRM. Thus, business process strategy is likely to impact firm performance positively. A model representing the relationship between business process strategy and firm performance using SEM-based path analysis was tested next. Below is analysis SEM for business process strategy finding.

5.2 Research Finding

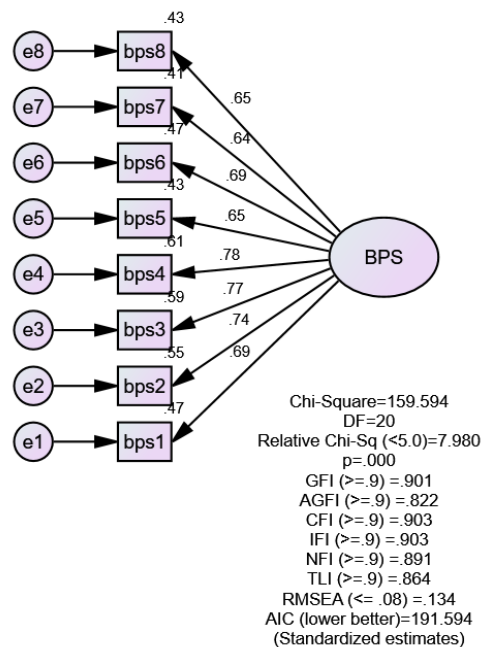

Table 3:SEM Analysis Business Process Strategy

SEM analysis can handle complicated relationships among dependent variables simultaneously and multiple independent (Anderson & Gerbing, 1988). Moreover, by structural model simultaneously and estimating measurement, SEM can allow relationships among constructs to be automatically corrected for measurement errors (Baumgartner, H. and Homburg, C. 1996).

According to Table 3 SEM Analysis Business Process Strategy, the outcomes presented that the business process strategy is a leading feature of improving performance straight. Result of confirming analysis of variables showed that measurement model if variables are proper and all numbers and parameters of model is meaningful. Measurements of the highest in reflecting customer relationship management are the reward, it followed by business process strategy and customer relationship management performance.

From the data Table 3 we can see that the outcomes presented that the business process strategy is a leading feature of improving performance straight. Measurements of the highest in reflecting customer relationship management are the reward. The SEM path analysis resulted in a chi-square of 159.594, DF of 20. The relative chi-square was 7.980. Furthermore Good fit Index was .901. AGFI was .822. The comparative fit index was .903 and the IFI was .903. NFI was .891. TLI was .864 and last but not least RMSEA was .134 with 80 percent confidence level. The outcomes of this study exemplify that the improved business process strategy of customer relationship management performance industries is most influenced by how the capability of management to deliver prizes to customers. Application of customer priority also played a role in increasing the customer relationship marketing. The result as shown in Table 3 indicate that the results presented a significant relationship on the business process strategy and customer relationship management performance to advance marketing performance of the logistic service industries. Thus these findings sustain the research findings of Wahab et al., (2018) which shows that the quality of service mainly influences customer satisfaction. The SEM-based path model supports the positive and meaningful correlation of business process strategy. Therefore Hypothesis H3 is accepted.

6.0 DISCUSSION

Business process strategy helps SME's brand to sustain in the market with positive performance through cost reduction and higher profits. Loyal customer usually tends to pay more as well as spreading positive word of mouth among friends and family. This is beneficial for business performance of SME given they highly rely on customer recommendations to get new customers. Besides, loyal customer needs little influencing effort to make purchase decision too. In other word, the effectiveness of positive word of mouth will help reduce cost of SME business strategy from investment in advertisement in order to gain awareness until the purchase is made. Furthermore, such advertising investment has high risk of no success guarantee. Apart from that, SME brands with already limited financial resources will face higher probability of being eliminated out of the market when customers did not return to make repeated purchase given the high number of SMEs business establishment in the

logistic service industry mentioned above. Therefore, it is vital for SME brands to capture loyal customers to ensure ongoing revenues and profits.

Innovation and technopreneurship is a new idea, method or devices that used a technology in order to improve something products or services into something new and translating a new ideas into tangible products. It will create new dimensions of performance from good to better use. Before it create new dimension, entrepreneurs need to understand the concept of innovation so the finished goods in a better performance (Shah et al.,2019).Embodiment, combination or synthesis of knowledge in original, relevant, valued new products, processes, or services is a concept that needs to understand. All the innovation must considered the use of technology.

By using business process strategy,organization can expand products and services through the world and can match those according on places and situations. To achieve that, sales must be made aggressively in order to reach the target and generate more profits. Using the right platform, sales can reach the target. Products and services that meet customers' needs and wants will be something memorable to them and they will automatically loyal to use the products or services and achieve their satisfaction and it will generate more profit because of continuously used from the customers. We can see that the right way of sales will attract customers to buy and use the products and services.

7.0 CONCLUSION

Based on the point above, the conclusion that we can make it is, with the right business opportunity that entrepreneurs discover and do it to meet the customers' needs and want will attract the customers to try a new product and services. Used the right or proper platforms to promote and sales will also tie the customers' heart and if they found the products and services meet their need; they will automatically be a loyal customers and satisfy. As a conclusion, business opportunity, innovation, technology, sales and customers are very important in business world. An entrepreneur must use it in positive ways and make sure the business can built based on customer's needs and wants.Entrepreneur also must be more innovation and creative. The innovation may upgrade the sales and performance as well as Malaysia economic growth.

In summary for the informants in this study exemplify that improved business process strategy of customer relationship management performance industries is most significant relationship by how the capability of management to deliver product and service to customers. Application of customer priority also played a role in increasing the customer relationship marketing (Hussin et al.,2020).

REFERENCES

- Anderson, J.C. & Gerbing, D.W. (1988). Structural equation modeling in practice: a review and recommend two-step approach. *Psychological Bulletin*, 103 (3), 411-423.
- Andrew F. Hayes (2009): Beyond Baron and Kenny: Statistical Mediation Analysis in the New Millennium, *Communication Monographs*, 76:4, 408-420 To link to this article: <http://dx.doi.org/10.1080/03637750903310360>.
- Abhishek D, Johnson LW, Charles WD (2018) Consumer emotional brand attachment with social media brands and social media brand equity. *Eur J Mark* 43(3):276–292
- Brdiger EK & Wood A (2017) Gratitude mediates consumer responses to marketing communications. *European Journal of Marketing* 51(1): 44– 64.
- Baumgartner, H. and Homburg, C. (1996), “Applications of structural equations modelling in marketing and consumer research: a review”, *International Journal of Research in Marketing*, Vol. 13, pp. 139-61.
- Beauducel, A. and Wittman, W. (2005), “Simulation study on fit indices in confirmatory factor analysis based on data with slightly distorted simple structure”, *Structural Equation Modeling*, Vol. 12, pp. 41-75.
- Brown, R. L. (1997). Assessing specific mediational effects in complex theoretical models. *Structural Equation Modeling*, 4, 142_156.
- Crockett, S. (2012). A five-step guide to conducting SEM analysis in counselling research. *Counselling Outcome Research and Evaluation*, 3(1), 30-47
- Chen and Popovich (2003) Understanding customer relationship management (CRM) *Business Process Management Journal*;9 (5), 672-688.
- Dehghanpouri, H., Soltani, Z. and Rostamzadeh, R. (2020), "The impact of trust, privacy and quality of service on the success of E- CRM: the mediating role of customer satisfaction", *Journal of Business & Industrial Marketing*, Vol. ahead-of-print No. ahead-of-print. <https://doi.org/10.1108/JBIM-07-2019-0325>
- D. Gefen, D. W. Straub, and M. Boudreau, (2000)“Structural equation modeling and regression: Guidelines for research practice,” *Commun. AIS*, vol. 4, pp. 1–78.
- Edenat, M.A. (2018), 'Reinforcing Innovation Through Transformational Leadership: Mediating Role of Job Satisfaction', *Journal of Organizational Change Management*, vol. 4, pp. 810-838.
- Fornell, C., & Larcker, D. F. (1981). Structural equation models with unobservable variables and measurement error: Algebra and statistics. *Journal of Marketing Research*, 18, 382-388. doi:10.2307/3150980
- Hair, J., Black, W., Babin, B., Anderson, R., & Tatham, R. (2010). SEM: An introduction. *Multivariate data analysis: A global perspective*, 629-686.
- Hair, J.F., Black, W.C., Babin, B.J., Anderson, R.E.(2010), *Multivariate Data Analysis, A Global Perspective*. 7th ed. New Jersey:, Pearson Education Inc.
- Islam, J. U., Rahman, Z., & Hollebeek, L. D. (2017). Personality factors as predictors of online consumer engagement: An empirical investigation. *Marketing Intelligence & Planning*, 35(4), 510–528.
- Krejcie, R. V. and D. W. Morgan. (1970). Determining Sample Size for Research Activities. *Educational and psychological measurement*, 30, 607-610.
- Muhamad Fairos mohamad shah, Samsudin Wahab (2020). Determining Of Customer Relationship Management Performance Characteristic: An Authentic Study among Logistic Operators SME's. *Preceding of The 2nd International Conference on Economics, Entrepreneurship and Management 2020*. Paper ID : ICEEM 2020: 030-023 , Retrieved from Website: <http://www.tijarahholdings.com/conference>
- Muhamad Fairos Mohamad Shah (2020) Kesetiaan Perhubungan Pelanggan Terhadap Skrin Penghantaran Perkhidmatan Kecil Sederhana *Journal Al-Takamul Al-Ma'Rif* Vol. 3 Issue 1., pg 1-12 ISSN: 2716-6899 ,E: ISSN: 2716-6902., Retrieved from www.al-takamul-marifi.my
- Muhamad Fairos Mohamad Shah, Samsudin Wahab, Anas Tajudin., (2019), The Relationship between Technology, Financial and Location Strategies and CRMP among Logistics Service Providers., *Journal of Business Management and Accounting*, Vol. 9 (1), 15-25.
- Muhamad Fairos Mohamad Shah (2019) Exploring Characteristic Of Customer Relationship Management Performance In Business Satisfaction Provider. *Proceeding Palm Oil: Economic Colloquium 2019* Retrieved From <https://Mpub.Gov.My>
- Muhamad Fairos Mohamad Shah (2019) Hubungan Di Antara Kesetiaan Perhubungan Pelanggan Terhadap Teknologi Penghantaran Perkhidmatan Kecil sederhana. *Proceeding Seminar Penyelidikan Kebangsaan Penyelidikan Pemangkin Kecemerlangan Pendidikan*. F25 143-150. Eisbn: 978-983-2084-48-8, Retrieved From <https://Seminarfpe.Wixsite.Com/Spk2019>
- Muhamad Fairos Bin Mohamad Shah & Samsudin Bin Wahab (2019), Customer Relationship Management Association On Financial Strategy Logistic Service. *Presiding International Conference On Design Industries And Creative Culture*. (P16). p2, Retrieved From <https://Designdecodeduitm.Wixsite.Com/Designdecoded2018>
- Muhamad Fairos Mohamad Shah And Samsudin Wahab (2019) Association Development Education Of Technology Strategy Performance On Customer Characteristic. *Proceeding International Conference On Education And Teacher Development (Iceted2019)*. Hc13, p14, Retrieved from <https://Iceted.Educonferences.Net/19/>.
- Muhamad Fairos Mohamad Shah, Samsudin Wahab, Mohd Amirul Mohd Rosli, (2018), Determination Competitive of Customer Relationship Management and Administration in Education, *Proceeding of 5th International Education Postgraduate Seminar (5th IEPS 2018)*, pp19 ID 5 retrieved from <https://educ.utm.my/ieps2018/>.
- Muhamad Fairos bin Mohamad Shah, Samsudin b Wahab, Norhayati bt Hussin (2018). The contributing Factors of Business Process Strategy on Customer Relationship Management Performance: A Pilot Study among SME's logistic operator. *3rd International Conference on Information Science*, 006;22 *The Journal of fundam.App.Sci*;10(5s)841-850. Retrieved from <http://www.ipneducationgroup.org/>.
- Muhamad Fairos Mohamad Shah, Samsudin Wahab, M. Hussin Abdullah (2018) Characterising of Customer Relationship Management and corporate entrepreneurship: A Case Study in a Malaysia logistic service. *The 5th IBSM International Conference on Business, Management and Accounting*. Paper Code : M13 – 136. 145-153.
- Muhamad Fairos Mohamad Shah, Anas Tajudin and Samsudin Wahab (2018) The Association Of Financial Strategy Characteristic On Customer Relationship Management Performance Characteristic: An Actual Study Among Sme's Logistic Operators. *International Journal of Research in Management & Social Science* Volume 6, Issue 2, 11 -16, (IV): April - June, 2018 ISSN 2322 – 0899.
- Muhamad Fairos Mohamad Shah, Samsudin Wahab, Anas Tajudin (2018) The Contributing Future Trends in Education of Financial Strategy on Customer Relationship Management Performance Characteristic: A Pilot Study among SME's Logistic Operators. *Proceedings of the International Conference on the Future of Education* 183(D20)114, ISSN 1985-1731. Retrieved from <http://www.iconfed> 2018.my.

- Muhamad Fairos bin Mohamad Shah, Samsudin b Wahab, Mohd Subri b Tahir (2017). The Contributing Factor of Technology Strategy on Customer Relationship Management Performance: A Pilot Study among SME's Logistic Operators. *The 4th World Conference on Islamic Thought and Civilization*, 147-154; *Journal of Thaqafah*. Retrieved from <http://www.wcit.my>.
- Muhamad Fairos bin Mohamad Shah, Samsudin bin Wahab (2017), The Contributing Factors of Location Strategy on Customer Relationship Management Performance: A Pilot Study among SME's Logistic Operators, *National Conference on Creativity in Education and Humanities*. OP54, *Journal of Economics, Business and Management* Retrieved from <http://www.ncc2017.usm.my/>.
- Muhamad Fairos bin Mohamad Shah, Samsudin b Wahab. (2017), The Mediating Effect Of Customer Intention Toward Customer Relationship Management Performance Among Malaysia Logistic Service Industries, *International Conference Islam Borneo (X)*, (Ekp 007), *International Journal of Entrepreneurial Behaviour & Research* Retrieved from: <http://www.kaib.com.my/>
- Muhamad Fairos b Mohamad Shah, Samsudin b Wahab, Mohd Subri b Tahir (2016). The determinant of Supplier 2 Customer Relationship Management Performance Model for SMEs. *International Conference on Post Graduate Education (ICPE-7)*; T02,47,(36) 1284-1293. *Journal of Information, Knowledge and Management* Retrieved from <http://www.ipsis.uitm.edu.my/icpe7/>.
- Muhamad Fairos b Mohamad Shah, Samsudin b Wahab, Mohd Subri b Tahir (2016). Customer-Supplier Relationship Management Performance Model for SMEs: The Integration of Financial and Technology Strategy. *Advances in Business Research International Journal*, 2 (2), 567 17-26. Retrieved from: www.abric2016.uitm.edu.my/
- Muhamad Fairos bin Mohamad Shah, Samsudin b Wahab, Mohd Subri b Tahir (2016). Customer-Supplier Relationship Management Performance Model for SMEs: Missing Link between Logistic and Business Intermediaries, *ASEAN Entrepreneurship Journal AEJ*, 2(2), 16-26, (ISSN 2289-2125) Retrieved from <http://aej.uitm.edu.my/>
- Norhayati Hussin, Muhamad Fairos Mohamad Shah. (2020) Technology Impact Of Customer Relationship Management Performance Characteristic among Logistic Operators SME's. *Preceding of International Business Information Management Conference (35th IBIMA) Seville, Spain 1-2 April, 2020 (ISBN: 978-0- 9998551-4-0) .Journal of Innovation Management in Small and Medium Enterprises.*; <https://www.ibimapublishing.com>.
- Nunnally, J.C. (1978). *Psychometric theory* (2nd ed.). New York: McGraw-Hill.
- Paddeu D, Fancello G, Fadda P (2017) An experimental Customer Satisfaction Index to evaluate the performance of city logistics services. *Transport* 32(3):262-271
- Sekaran, U. and Bougie, R. (2013) *Research Methods for Business: A Skill-Building Approach*. 6th Edition, Wiley, New York.
- Samsudin Wahab, Sofea Adriana A Jamalulil, and Muhamad Fairos bin Mohamad Shah (2017) The Relationship between Service, Process, Organization and Marketing Innovations towards Firm Performance: Views of Broadcasting Industry in Malaysia. (AEMS 2017) *International Conference on Advanced Education and Management Science* 2335, 125-129 Retrieved from <http://www.aems2017.org/>.
- Soh KL, Chin SH, Wong WP (2017) A theoretical model to investigate customer loyalty on logistics service providers for sustainable business performance. *Int J Bus Perform Supply Chain Model* 7(3):212-223
- Sobel, M. E. (1982). Asymptotic confidence intervals for indirect effects in structural equation models. In S. Leinhardt (Ed.), *Sociological methodology* (pp. 290-312). San Francisco: Jossey-Bass.
- Sobel, M. E. (1986). Some new results on indirect effects and their standard errors in covariance structure models. In N. Tuma (Ed.), *Sociological methodology* (pp. 159-186). Washington, DC: American Sociological Association.
- Tharikh, S. M., & Hamzah, S. R. (2020). Application of The Wellbeing Theory on Air Traffic Controllers: A Model on How to Flourish in Practice at The Workplace. *International Journal of Academic Research in Business and Social Sciences*, 10(5), 522-532.
- Thammawimutti, A., & Chaipoopirutana, P. D. S. (2018). The relationship between brand equity, product attributes and purchase intention: A study of Sony digital cameras in Bangkok. *AU Journal of Management*, 3(1), 5-10.
- Wahab, S.N., Bahar, N. and Mat Radzi, N.A. (2019) 'An Inquiry on Knowledge Management in Third-party Logistics Companies', *International Journal of Business Innovation and Research*, DOI: 10.1504/IJBIR.2020.10024101
- Wahab, S.N., Sayuti, N.M. and Talib, M.S.A. (2018) 'Antecedents of Green Warehousing: A Theoretical Framework and Future Direction', *International Journal of Supply Chain Management*, Vol. 7, No. 6, pp. 382-388.

PENSIJILAN HALAL: SEJAUH MANAKAH ORGANISASI DALAM INDUSTRI HALAL DI MALAYSIA MENJAMIN PEMATUHAN TERHADAP PIAWAIAN HALAL?

Nainatul Farzuha Nor^a & Mohd Faizuddin Muhammad Zuki^b

^a*School of Business Management, Universiti Utara Malaysia, Malaysia*

^b*Islamic Business School, Universiti Utara Malaysia, Malaysia*

Abstrak

Kajian ini bertujuan untuk melihat pematuhan organisasi industri makanan halal yang telah mempunyai pensijilan halal namun masih pincang dalam mematuhi piawaian yang telah ditetapkan. Industri makanan halal kini telah mengalami kepesatan global dan berkembang dengan begitu pantas sekali, yang bukan sahaja berlaku di Malaysia. Pensijilan halal merupakan langkah permulaan bagi setiap organisasi untuk menjalankan perniagaan dalam industri pemakanan halal. Prestasi organisasi dinilai berdasarkan keberkesanan dan kecekapan dalam pematuhan sijil halal. Realitinya prestasi berkesan bagi pengurusan makanan halal dalam kalangan industri halal masih mengalami kepincangan dan tidak memenuhi piawaian yang ditetapkan berdasarkan standard dan garis panduan yang digunakan. Kajian mendapati bahawa pematuhan sijil halal dipengaruhi oleh satu rangkaian yang berhubung kait antara satu sama lain bermula daripada input, kemudiannya diterjemahkan dalam bentuk proses dan akhirnya menghasilkan pencapaian yang turut disokong oleh kawalan dalaman organisasi. Kajian ini adalah berbetuk kajian awal berdasarkan daripada kajian literasi kajian-kajian lepas yang matang dalam bidang industri makanan halal di Malaysia. Hasil kajian ini diharapkan dapat memberi nilai tambah melalui kawalan dalaman awal oleh organisasi sebelum penilaian dibuat oleh pihak autoriti dalam pensijilan halal di Malaysia.

Kata kunci: Pengurusan pensijilan halal, amalan piawaian, prestasi organisasi dan industri makanan halal

1.0 PENGENALAN

Industri Halal merupakan satu pasaran yang semakin berkembang pesat di peringkat antarabangsa dan juga di Malaysia. Malaysia yang mempunyai populasi penduduk Muslim yang besar, telah memberi peluang kepada kerajaan untuk menjadikan Malaysia sebagai negara hab halal yang pertama di dunia. Antara usaha kerajaan dalam perkembangan halal di Malaysia adalah perlaksanaan amalan prosedur pensijilan halal dan piawaian seperti Standard Halal Malaysia MS1500:2009, *Good Manufacturing Practice* (GMP) dan *Hazard Analysis and Critical Control Points* (HACCP).

Umat Islam di serata dunia dan di Malaysia terutamanya, amat menitikberatkan aspek makanan dan produk penghasilannya. Meskipun, lambakan produk makanan di pasaran pada hari ini yang memberikan variasi kepada pemilihan makanan, pengguna Islam di Malaysia masih meletakkan soal kehalalan sebagai keutamaan. Konsep halal dan haram telah digariskan oleh Allah S.W.T di dalam Al-Quran menerusi surah Al-Baqarah ayat 168 yang bermaksud: “*Wahai sekalian manusia! Makanlah dari apa yang ada di bumi yang halal lagi baik, dan janganlah kamu ikut jejak langkah Syaitan; kerana sesungguhnya Syaitan itu ialah musuh yang terang nyata bagi kamu*”.

Penggunaan konsep halal dan tayyiban dapat menentukan sesuatu makanan merangkumi aspek tersurat (fizikal) dan tersirat (yang tidak nampak secara zahir). Tayyiban ditakrifkan sebagai makanan yang bersih tanpa sebarang kotoran, sumber yang halal, pengambilannya tidak mendatangkan penyakit dan mudarat dan mempunyai nilai pemakanan serta elemen manfaat (Arif & Sidek, 2015). Penggunaan tayyib juga menumpukan kepada kehalalan sesuatu makanan dengan ciri-ciri baik, sedap, lazat dan berkhasiat.

Tafsiran Ibnu Kathir terhadap ayat tersebut dengan jelas menerangkan tentang konsep halal dan tayyiban yang menyatakan bahawa segala makanan yang telah dianugerahkan oleh Allah di muka bumi ini adalah halal kecuali terdapat dalil yang mengharamkannya. Ini bertujuan untuk memberi kemanfaatan dan kebaikan kepada jiwa dan fizikal manusia. Selanjutnya, pengabdian diri kepada Allah adalah sebagai tanda kesyukuran di atas nikmat rezeki yang dikurniakan kepada hamba-Nya (Kathir, 2000). Secara jelas, Allah telah mengurniakan kepelbagaian nikmat makanan di atas muka bumi ini dan pulangan manfaat dan kelebihan yang terdapat padanya akan kembali kepada diri umat manusia itu sendiri.

Penerimaan produk halal terutama produk makanan halal oleh pengguna Muslim dan bukan Muslim adalah bergantung kepada kualiti, keselamatan, kebersihan dan kandungan nutrisi produk tersebut. Pensijilan halal merupakan faktor utama yang menarik pengguna untuk memilih produk makanan halal di Malaysia sekaligus meyakinkan pengguna mengenai status halal. Produk makanan yang diambil atau dihasilkan yang memenuhi konsep halalan tayyiban akan memberi kelegaan kepada umat Islam kerana jaminan kualiti, kebersihan dan keselamatannya (Awan, 2019). Selain itu pensijilan halal merupakan satu nilai komersial perdagangan iaitu *marketing tools* untuk meraih pasaran dalam dan luar negara (Ab. Rahman, 2009).

Namun, kini terdapat pelbagai isu berkaitan pensijilan halal dan penyalahgunaan logo halal di kalangan *practitioner* industri makanan halal. Pensijilan halal yang dijadikan alat pemasaran tersebut telah disalahguna oleh segelintir syarikat menyebabkan berlaku isu-isu seperti pemalsuan logo, penyalahgunaan dan penyelewengan logo halal, kepelbagaian logo halal di pasaran dan ketidakpatuhan pengusaha terhadap piawaian yang telah ditetapkan.

Pada tahun 2018, sebuah kilang makanan ringan di Chemor, Perak telah mempamerkan logo halal palsu rentetan daripada sijil halal sedia ada telah tamat tempoh iaitu pada April 2016 (Othman, 2018). Sumber yang dikeluarkan oleh Astro Awani (2019), sebuah premis makanan di Kepong telah diarahkan untuk menutup perniagaan kerana logo halal yang dipamerkan keadaan bahagian dapur premis berada dalam keadaan tidak mematuhi piawaian yang digariskan seperti tidak teratur dan dipenuhi dengan serangga yang berkeliaran (Awani, 2019). Melihat kes di negeri lain seperti Kota Bharu, Kelantan pula, sebuah premis restoran disiasat rentetan daripada penggunaan logo halal yang telah tamat tempoh (Muhammad Basir Roslan, 2019).

Justeru, pematuan sijil Halal yang diperolehi merupakan satu faktor penting kepada pengusaha atau pengeluar produk makanan untuk memaksimumkan keuntungan, menarik pengguna Muslim untuk membeli produk dan menjamin produk halal yang dikeluarkan menepati piawaian halal. Namun, persoalan yang berlegar ialah sejauhmanakah pengusaha atau pengeluar produk tersebut mematuhi piawaian yang telah ditetapkan? Atas kesedaran terhadap pematuan piawaian halal yang menjadi faktor penting dalam industri makanan di Malaysia, maka kajian mengenai pematuan piawaian halal ini dijalankan.

2.0 SOROTAN LITERATUR

2.1 Pengurusan Sijil Halal

Pensijilan halal merupakan langkah permulaan oleh sesebuah organisasi mendapatkan dokumen yang dikeluarkan oleh pihak berautoriti iaitu Jabatan Kemajuan Islam (JAKIM) untuk mengesahkan sesuatu produk itu mengikut garis panduan halal dan haram dalam Islam (*Islam Dietary Guideline*) yang telah ditetapkan (Riaz & M. Chaudry, 2003). Produk yang mendapat pensijilan halal lebih cenderung untuk mendapat kepercayaan daripada pengguna Muslim serta menarik minat pengguna bukan Muslim dari aspek kualiti halal produk tersebut.

Pensijilan halal yang diperolehi membolehkan organisasi tersebut menggunakannya sekali gus mempamerkan logo halal di premis serta produk yang dikeluarkan. Sijil halal dan logo halal yang diperolehi oleh organisasi boleh mempengaruhi beberapa faktor seperti berikut:

i) **Kepentingan kepada pengguna Muslim dan bukan Muslim**

Gelagat pengguna Muslim dan bukan Muslim pada masa kini lebih mementingkan produk yang mendapat sijil halal dalam memilih makanan bagi menjamin kebersihan, kualiti, keselamatan dan kandungan nutrisi dalam makanan tersebut. Justeru, pengguna akan lebih tertarik untuk membeli produk makanan yang mempunyai logo halal.

ii) **Nilai komersial perdagangan (*Marketing Tools*)**

Atas kesedaran dan permintaan pengguna terhadap produk makanan halal, secara tidak langsung ianya mempengaruhi para pengusaha dan pengeluar produk makanan untuk mendapatkan sijil halal sebagai salah satu nilai komersial perdagangan (*marketing tools*) bagi menarik pengguna untuk membeli produk mereka. Perkara ini menjadi satu kelebihan kepada organisasi yang mempunyai sijil halal kerana lebih mendapat perhatian daripada kalangan pengguna.

Namun, organisasi yang tidak mematuhi piawaian halal yang telah ditetapkan akan mengakibatkan sijil halal yang telah diperolehi akan ditarik serta merta oleh pihak berkuasa. Justeru, organisasi tersebut perlu “menjaga” sebaik mungkin sijil halal yang diperolehi kerana ia menjadi faktor kepada prestasi organisasi.

Melihat kepada kepentingan kesan pensijilan halal, sebilangan pemilik perniagaan menyalahgunakan logo pensijilan palsu dan sebahagian besar industri makanan yang mempamerkan logo halal adalah bagi tujuan menarik pengguna demi kepentingan perniagaan semata-mata tanpa memahami amalan di balik konsep halal.

2.2 Amalan Piawaian

Piawaian dan prosedur halal telah diperkenalkan dalam industri halal adalah bagi memastikan organisasi mematuhi garis panduan yang telah ditetapkan oleh badan berkuasa halal iaitu Jabatan Kemajuan Islam Malaysia (JAKIM) (Buang & Hidayat Mahmud, 2012). Organisasi yang telah mempunyai pensijilan halal, perlu mengamalkan dan mematuhi piawaian yang ditetapkan sebagai salah satu langkah untuk meningkatkan prestasi organisasi. Menyentuh aspek amalan pematuan piawaian ini, ia menjadikan Malaysia terkenal di mata dunia sebagai negara hab halal. Walaupun pasaran produk halal di Malaysia berskala kecil, tetapi Malaysia terkenal di persada antarabangsa dalam industri halal kerana mempunyai standard halal yang digunapakai sebagai piawaian asas pensijilan halal (Sungkar, 2009).

Terdapat beberapa kajian yang membuktikan bahawa amalan pematuan piawaian (operasi) mampu meningkatkan prestasi organisasi pengeluar makanan halal. Kajian daripada Sitky Ilkay dan Aslan (2012) menunjukkan bahawa amalan pengurusan kualiti meningkatkan prestasi organisasi. Huo, Han dan Prajogo (2014) melihat keberkesanan pelaksanaan ISO 9000 terhadap peningkatan prestasi organisasi. Pematuan dan pelaksanaan pensijilan Halal boleh diukur melalui empat (4) aspek utama iaitu amalan halal dan *toyyiban*, proses dalaman organisasi, sistem jaminan halal dan pengurusan sumber manusia (Sitti dan Risyawati, 2018).

Baharudin, Sharifudin, Arsiah dan Nurul (2018) menyatakan dalam kajian bahawa amalan piawaian halal bagi sesebuah organisasi merujuk kepada tanggungjawab dan usaha organisasi tersebut untuk mematuhi piawaian halal yang telah ditetapkan dalam pensijilan halal. Antara aspek-aspek yang dititikberatkan dalam pematuan piawaian halal bagi sesebuah organisasi adalah seperti aspek dokumentasi, sistem rekod, kebersihan makanan, pekerja, bahan kandungan makanan, peralatan pekerjaan, pembungkusan, penyimpanan, pemprosesan, pengangkutan, pengurusan sisa buangan dan jaminan halal. Sekiranya setiap aspek tersebut boleh dipatuhi maka organisasi tersebut berjaya dalam pematuan piawaian halal yang ditetapkan.

Selain itu, menurut Zulzaidi Mahmood (2011) dalam kajian yang dijalankan, beliau menyatakan bahawa amalan piawaian terhadap pematuan pensijilan halal bagi pengusaha makanan halal terbahagi kepada tiga (3) aspek iaitu:

i) Aspek Persekitaran/ Tempat Kerja

Amalan piawaian dari aspek persekitaran/ tempat kerja meliputi aspek kebersihan, pemprosesan, kawasan pekerja, keselamatan dan sebagainya. Sekiranya semua aspek dipatuhi bertepatan dengan piawaian yang telah ditetapkan, maka JAKIM akan memberikan pensijilan Halal. Bagi pensijilan *Hazard Analysis and Critical Control Point* (HACCP) dan *Good Manufacturing Practices* (GMP), Kementerian Kesihatan menitikberatkan aspek-aspek yang memenuhi spesifikasi yang ditetapkan. Menurut Idris (2017), piawaian HACCP dan GMP sangat penting kepada organisasi untuk menjadi kebolehsaingan produk di peringkat antarabangsa (Mahmod, 2011).

ii) Aspek Peralatan Pekerjaan

Dari aspek peralatan pekerjaan, JAKIM telah menetapkan syarat bagi mendapatkan pensijilan halal, peralatan yang hendak digunakan perlu memenuhi kehendak Islam dan bertepatan dengan syarat-syarat yang ditetapkan di dalam Manual Prosedur Pensijilan Halal Malaysia. Sebagai analogi; pensijilan halal yang dikeluarkan kepada dapur di hotel, JAKIM menetapkan peralatan yang digunakan seperti pisau, kuai, pinggan dan sebagainya adalah terdiri daripada peralatan yang diperbuat daripada bahan yang halal serta diasingkan daripada barang-barang yang terdiri daripada bahan yang haram.

iii) Aspek Barang Jualan

Menurut Zulzaidi, produk barangan yang dijual hendaklah dibuat tempat pengasingan dan mengikut prinsip muamalah serta tiada unsur penipuan dalam penjualan seperti aspek pemprosesan makanan, kandungan produk, timbangan, tanda bahan produk dan sebagainya.

2.3 Prestasi Organisasi Halal

Prestasi organisasi didefinisikan sebagai kepelbagaian dimensi untuk mencapai matlamat organisasi dan mempunyai hubungan dengan matlamat strategi organisasi (Mwita, 2000). Cagnazzo, Taticchi dan Fuiano (2009), menekankan bahawa pengurusan prestasi sesebuah organisasi bergantung kepada aspek kualiti dalaman organisasi. Kebanyakan kajian imperikal terdahulu, pengkaji menunjukkan bahawa prestasi organisasi bergantung kepada prestasi kewangan seperti penjualan, ROA, ROI dan prestasi bukan kewangan seperti kualiti, masa dan pengurusan (Feng et al., 2007).

Prestasi organisasi halal memainkan peranan penting dalam industri halal yang semakin mendapat permintaan tinggi oleh pengguna Muslim dan bukan Muslim. Organisasi yang mengeluarkan produk makanan perlu merebut peluang ini dengan meningkatkan prestasi untuk lebih berdaya saing. Dube (2016) menyatakan dalam kajiannya bahawa pensijilan Halal merupakan tiket untuk menembusi pasaran Halal tempatan dan pasaran antarabangsa bagi mengukur prestasi organisasi industri halal. Organisasi yang mendapat pensijilan halal akan mendapat permintaan yang tinggi berbanding organisasi yang menjual produk halal tetapi tidak mempunyai sijil halal kerana tidak mendapat kepercayaan dan keyakinan daripada para pengguna terhadap produk yang dikeluarkan (Dubé et al., 2016).

Kajian Feng (2008) mendapati prestasi perniagaan halal berdasarkan prestasi operasi organisasi dan kewangan organisasi. Kajian ini mendapati bahawa pensijilan halal mempunyai hubungan dengan prestasi perniagaan. Psomas et al. (2013) juga menemukan dalam kajiannya bahawa pensijilan halal mempengaruhi prestasi kewangan dan operasi organisasi (Psomas et al., 2013). Pelaksanaan operasi halal yang komprehensif dan sistematik membuktikan bahawa pensijilan Halal meningkatkan permintaan produk halal.

Selain itu, sebuah kajian daripada Abdul et al. (2013) turut membuktikan bahawa pensijilan halal membawa kejayaan dan meningkatkan prestasi organisasi yang mengeluarkan produk halal (Abdul et al., 2013). Prestasi perniagaan halal diukur berdasarkan aspek nilai Islam, peningkatan kewangan, sumbangan kepada masyarakat, pengurusan sumber manusia dan pencapaian fizikal organisasi.

3.0 METODOLOGI KAJIAN

Bahagian ini akan menerangkan kaedah kajian termasuklah kaedah pengumpulan data dan juga metode analisis data yang digunakan dalam kajian ini. Kajian ini mengaplikasikan kaedah analisis kajian daripada kajian-kajian lepas yang berkaitan dengan penyelidikan pematuhan organisasi terhadap piawaian halal.

4.0 DAPATAN KAJIAN & PERBINCANGAN

Melalui beberapa kajian imperikal tersebut, terbukti bahawa pensijilan halal mempunyai hubungan dalam prestasi organisasi makanan halal. Prestasi organisasi halal semakin meningkat akibat daripada permintaan yang tinggi daripada pengguna Muslim dan juga pengguna bukan Muslim yang lebih mempercayai produk halal yang dikeluarkan oleh syarikat yang telah mendapat pensijilan halal.

Namun, adakah semua organisasi pengeluar produk halal terutama makanan halal mematuhi piawaian yang telah ditetapkan sedangkan kajian sudah membuktikan bahawa pematuhan terhadap piawaian halal membantu meningkatkan prestasi organisasi. Hal ini kerana pengguna Muslim dan bukan Muslim sentiasa berwaspada terhadap syarikat yang mempunyai pensijilan halal dan logo halal berbanding syarikat yang mengeluarkan produk halal tetapi tidak mendapat pengesahan sijil daripada JAKIM. Pengguna kini lebih bijak dalam memilih dan membeli produk halal kerana produk halal menjamin kualiti, kebersihan, kesihatan dan nutrisi yang baik kepada pengguna.

Menurut Pengarah Kementerian Perdagangan Dalam Negeri & Hal Ehwal Pengguna (KPDNHEP) Terengganu, Shahrudin Mohd Kia, kebanyakan premis yang tidak mematuhi piawaian halal yang telah ditetapkan akan mengakibatkan premis perniagaan terpaksa ditutup atau prestasi perniagaan semakin menurun kerana permintaan pengguna semakin kurang (Mustafa, 2019). Menurut beliau lagi, kebanyakan premis yang menyalahgunakan logo halal hasil daripada pensijilan halal tamat tempoh tetapi tidak diperbaharui, akan dikenakan kompaun dan secara tidak langsung akan menjejaskan imej prestasi syarikat tersebut.

Syazwan dan Thoo (2017) melalui sebuah kajian membuktikan bahawa walaupun sesebuah organisasi mempunyai pensijilan halal, namun sekiranya sijil halal dan logo halal hanya dijadikan sebagai alat persembahan atau lakonan, maka organisasi tersebut tidak dapat mengekalkan prestasi perniagaan halal dan seterusnya akan menjejaskan

integriti organisasi tersebut. Organisasi yang tidak patuh pada piawaian halal adalah organisasi yang tidak berintegriti dalam menjalankan perniagaan halal.

Selain itu, kajian imperikal daripada Talib et al. (2015), juga menjelaskan tentang pemahaman mengenai fungsi pematuhan terhadap piawaian pensijilan halal (Talib et al., 2015). Penulis menekankan pengurus syarikat makanan halal perlu memastikan pelaksanaan operasi syarikat adalah mematuhi MS1500 yang telah ditetapkan oleh badan autoriti halal. Hal ini mempunyai hubungan dalam peningkatan prestasi halal.

5.0 KESIMPULAN

Kesimpulannya, berdasarkan penelitian daripada beberapa kajian, hasil perbincangan mendapati organisasi yang mendapat pensijilan halal perlu mematuhi piawaian halal yang telah ditetapkan semasa menjalankan perniagaan halal demi menjamin prestasi perniagaan. Pensijilan halal tidak hanya boleh dipamerkan, sebaliknya perlu dilaksanakan untuk mempengaruhi gelagat pembelian pengguna kerana teori pengguna yang mempunyai kuasa beli dalam permintaan produk makanan halal. Pematuhan piawaian tersebut menjadi satu kelebihan daya saing dalam mengharungi dunia perniagaan makanan halal yang semakin berkembang pada masa kini.

RUJUKAN

- Ab. Rahman, L. (2009). *Isu Halal Tiada Penghujung*. Melaka: Alambaca Sdn.Bhd.
- Abdul, M., Ismail, H., & Mustapha, M. I. (2013). Halal Food Certification: Case of Malaysian SME Entrepreneurs. *China-USA Business Review*, 12(2), 163–173.
- Arif, S., & Sidek, S. (2015). Application of Halalan Tayyiban in the Standard Reference for Determining Malaysian Halal Food. *Asian Social Science*, 11(17), 117–129.
- Awang, N. (2019). *Konsep Halal Tayyiban dan Trend Pemilihan Makanan Umat Islam Kini*.
- Awani, A. (2019). Sijil halal palsu, dapur berlipas antara sebab restoran diarah tutup. *Astro Awani*. <https://www.astroawani.com/berita-malaysia/sijil-halal-palsu-dapur-berlipas-antara-sebab-restoran-di-arah-tutup-197169>
- Buang, A., & Hidayat Mahmud, Z. (2012). Isu dan Cabaran Badan Pensijilan Halal di Malaysia. *Shariah Journal*. *Shariah Journal*, 20(3), 271–288.
- Dubé, F. N., Hongxia, Z., Haijuan, Y., & Lijun, H. (2016). Halal Certification System as a Resource for Firm Internationalisation : Comparison of China and Malaysia. *International Journal of Asia Pacific Studies*, 12(1), 125–141.
- Feng, M., Terziovski, M., & Samson, D. (2007). Relationship of ISO 9001:2000 quality system certification with operational and business performance. *Journal of Manufacturing Technology Management*, 19(1), 22–37.
- Kathir, I. (2000). *Tafsir Ibn Kathir*. Dar al-Salam.
- Mahmod, Z. (2011). *Pelaksanaan Pemantauan Dan Penguatkuasaan Undang-Undang Produk Halal Di Malaysia: Kajian Terhadap Penyalahgunaan Logo Halal*.
- Mustafa, R. (2019). Salah guna sijil halal, dua peniaga dikompau. *Sinar Harian*. <https://www.sinarharian.com.my/article/46413/EDISI/terengganu/Salah-guna-sijil-halal-dua-peniaga-dikompaun>
- Othman, F. S. (2018). *Kilang makanan ringan pamer logo halal palsu diserbu*. BH Online. <https://www.bharian.com.my/berita/kes/2018/07/454545/kilang-makanan-ringan-pamer-logo-halal-palsu-diserbu>
- Psomas, E. L., Pantouvakis, A., & Kafetzopoulos, D. P. (2013). The impact of ISO 9001 effectiveness on the performance of service companies. *Managing Service Quality: An International Journal*, 23(2), 149–164.
- Riaz, M. N., & M. Chaudry, M. (2003). *Halal Food Production* (1st ed.). CRC Press.
- Sungkar, I. (2009). The Global Halal Food Industry. *The Halal Journal*, 37.
- Talib, M. S. A., Hamid, A. B. A., & Ai Chin, T. (2015). Motivations and limitations in implementing Halal food certification: A Pareto analysis. *British Food Journal*, 117(11), 2664–2705.

HALAL TOURISM: MARKETING OPPORTUNITIES FOR HALAL ENTREPRENEURS

Mohamed Battour^a, Mohamed Salaheldeen^b & Khalid Mady^c

^aFaculty of Faculty of leadership and management, Universiti Sains Islam Malaysia (USIM), Malaysia

^bFaculty of Economics and Muamalat Administration, Universiti Sains Islam Malaysia, Malaysia

^cFaculty of Management & Economics and social development, Universiti Malaysia Terengganu, Malaysia.

Abstract

The objectives of this conceptual paper are to define Halal Tourism based on the current practices and to explore the available innovative business opportunities in Halal travel industry that could be exploited by Halal entrepreneurs. Critical assessment in Halal tourism literature is used to define Halal tourism and to link between Halal entrepreneurship and Halal tourism to explore innovative marketing opportunities for entrepreneurs. New Halal tourism definition is suggested based on the current practices in this field. The paper provided new prospects for Halal Entrepreneurs that could enable them to start new ventures in Halal tourism Industry.

Keywords: Halal tourism, Halal entrepreneurship, Muslim tourists.

1.0 INTRODUCTION

Innovation has become compulsory in the quest to achieve long term competitiveness. Absence of enough degree of innovation may pose a serious risk to the competitiveness in halal tourism industry. We believe this is the right time for entrepreneurs in the Halal space to play an important role. There are many opportunities that need to be explored and transferred into halal tourism product/services. This is not exclusively for Muslim but also could be for non-Muslim travellers (Battour, 2019; Battour, Hakimian, Ismail, & Boğan, 2018; Battour, Rahman, & Rana, 2019). There are some spheres of Halal travel which will be equally suitable for the non-Muslim market.

2.0 HALAL TOURISM AND ENTREPRENEURSHIP

All From both the industrial and the research viewpoint, tourism recognizes the increasing interest in Halal tourism. The 'Halal tourism' terminology is first time used in tourism literature by Battour (2010) in Scopus journal (C. Ryan, 2016). The common terminology before that was 'Islamic Tourism' which Henderson used (2009). Halal tourism is defined by Battour (2016) as "any object or action which is permissible to use or engage in tourism industry, according to Islamic teachings". Based on Battour definition, the objective of travel in Halal tourism is not necessary to be religious; it could be any of tourism motivations. Recently, it has been observed some other terminologies in Muslim travel market related to halal Tourism such as Halal/Muslim travel, Muslim friendly tourism, and Halal friendly destination (Abror, Patrisia, Trinanda, Omar, & Wardi, 2020; Battour, 2019; Battour et al., 2019; Han, Al-Ansi, Olya, & Kim, 2019; Yagmur, Ehtiyar, & Aksu, 2019). Most of these terms go around satisfying the needs of the Muslim traveller. Some practices related to these concepts have been observed in non-Muslim countries such as Japan, Australia and New Zealand (Al-Ansi & Han, 2019; Han et al., 2019; Rashid, Wangbenmad, & Mansor, 2020).

Muslim friendly term could be more suitable in Halal tourism when non-Muslim destinations are trying to promote itself as Muslim-friendliness. The friendliness is ignored totally in Halal tourism definition in previous literature (For example, Battour & Ismail, 2016; Boğan & Sarıışık, 2019; El-Gohary, 2016). Therefore, Halal tourism could be defined as any tourism object or action which is permissible according to Islamic teachings to satisfy the needs of the Muslim traveller and achieve the destination's Muslim-friendliness. This definition includes non-Muslim destination that are targeting Muslim travellers to be Muslim friendliness by satisfying their needs. We believe this revision will give enough space for entrepreneurs to play an important role either in Muslim or non-Muslim destination to penetrate Muslim travel market.

3.0 POTENTIAL INNOVATIVE OPPORTUNITIES FOR ENTREPRENEURS IN HALAL TOURISM

Halal entrepreneurs are driven by a profit seeking mission by using current and future market trends and customer demands in Halal tourism industry. At the same time, Halal Entrepreneurs should run the new venture that complies with sharia (Islamic law). Based on the current trends in Halal travel markets and tourism literature, the following innovative opportunities would attract Halal Entrepreneurs attention to create new products and services in Halal tourism industry.

Digital platform Era

Digital platform is playing a key component for providing products and services. Halal entrepreneurs might provide new digital platform that is personalized everything for Muslim travellers. They should look for extremely user-friendly apps that enable customer to share everything. It is noted recently that mobile applications add to the broad variety of information sources for goods, services and education (Sarwar, Haque, & Yasmin, 2013; Situmorang, Rini, & Muda, 2017). New Halal venture do not skip big, creative marketing opportunities by taking full advantage of personalized mobile messaging. In addition, new Halal venture that do not take full advantage of the real-time interaction generated by social media are missing the boat as an creative opportunity to target the entire young Muslim community (Fadahunsi & Kargwell, 2015; Idris & Rahman, 2017). Thus, to reach these digital natives, new brands must produce content that excites and ignites engagement.

Gen Alpha as a potential Muslim traveller

Gen Alpha might have a great impact on Halal travel market as potential Muslim tourist in next years. G-Alpha is a new generation holding anyone who has globally been born during the 2010-2025 period (McCrinkle, 2014). The cohort of generation Alpha is often an offspring of the Millennials and sometimes either Generations X, or Z (Tootell, Freeman, & Freeman, 2014). The hallmark of this Generation is naturally using technological devices such as smartphones and tablets (Thomas & Shivani, 2020). These children may be impossible to be kept away from their apps and devices, which have been an inseparable part of their lives since they were born (McCrinkle, 2014). They deal with the advanced technology to discover how it works without any fear. Many companies now adopt what can be termed generational marketing, which involves adapting the marketing-mix to a certain generation (Chaney, Touzani, & Ben Slimane, 2017). G-Alpha will have an essential role in determining their family travels choices and destinations (Seraphin & Green, 2019).

Blockchain-based Bitcoin Cryptocurrency

The Blockchain-based cryptocurrency which is not just a cryptographic -virtual- currency used for on line shopping transactions, but also a popular tool commonly used to hedge and speculate (Trimborn, Li, & Härdle, 2018). According to Ayedh et al. (2020), Muslim investors are keen to invest in Bitcoin market because of compatibility, awareness and facilitating conditions. Therefore, Halal entrepreneurs should use the creativity, transparency, and confidence of its decentralized core technologies (Abboushi, 2017; Antonopoulos, 2014; Böhme, Christin, Edelman, & Moore, 2015; Cocco, Pinna, & Marchesi, 2017; P. Ryan, 2017; Swan, 2017) As new ventures, it could provide payment services for Muslim travellers.

Sustainable Products and services

Sustainability in the tourism sector will become increasingly important in defining both business and consumer choices (Bhuiyan & Darda, 2018; Rezai, Mohamed, & Shamsudin, 2015). The United Nations and the media have played significant roles in raising awareness on a variety of tourism-related environmental issues. This includes the negative impacts that travel can have on the climate and culture. Concerns such as plastic use and climatic footprints are also in the spotlight. Moreover, the general wellbeing of all actors in the value chain, not just tourists, is coming to the fore (Testa, Galati, Schifani, Di Trapani, & Migliore, 2019).

Muslim female-friendly services

Muslim women make up 45 per cent of the Muslim travel market, according to the Mastercard-CrescentRating Report (MWIT) (2019). There are various of innovative opportunities to be exploited as new products and services to address this group's particular needs (Battour, 2019). Many of these women are young, educated and are actively involved in the workplace, in turn having a good purchasing power. Therefore, more Muslim women will

be encouraged to travel making this group as interesting opportunity for entrepreneurs in general, and halal entrepreneurs specifically (Salaheldeen, Battour, & Nazri, 2019).

Culinary tourism

Halal food becomes easily accessible in many destinations for catering to Muslim travellers. Therefore, the services and operators should adapt their culinary operations to be Muslim-friendly (Battour, 2018, 2019). Muslim travellers are now more curious in their choice of eating, thereby implicitly pushing several brands' gastronomic boundaries to shift to creative and unique Halal items. This could be easily recognized in many well-known brands and corporations that adopted Halal food manufacturing (Battour et al., 2019). Recently, culinary tourism has been a popular trend (Stone, Migacz, & Wolf, 2019), but Muslim travellers were often unable to participate in such activities due to their halal dietary requirements. Muslim travellers, like any other traveler, are keen to try local cuisines of the host communities, participate in a cooking class, a food tour or a festival as a way of learning and immersing themselves in local cultures (Testa et al., 2019).

Three-dimensional printing

The field of 3D printing has nowadays been considered as one of the attractive industries which are witnessing considerable growth within several manufacturing systems (Rong, Patton, & Chen, 2018). The 3D printing technology depends on using the software to design a prototype of an object and the 3D printers which are specially designed to add several layers of materials until the shape of a real object is completed. The materials that are used in such technology are real materials such as metals, plastics, and aluminum (Arbabian & Wagner, 2020). Highly customizing the products is one of the most important advantages of 3D printing, which allow the customer to modify the product without additional costs (Kwak, Kim, & Park, 2018).

Virtual Reality and Augmented Reality

It was noted recently a great interest to use Virtual reality (VR) and Augmented Reality (AR) in tourism context. Both technological advances improve the experience of visitors (Beck, Rainoldi, & Egger, 2019; Moro, Rita, Ramos, & Esmerado, 2019) by increasing the physical understanding of nature in which they can encounter the products and destinations when they are at homes (Loureiro, Guerreiro, & Ali, 2020). Moreover, VR plays a crucial role in travel interactions and attitudes, such as interplanetary journeys, fantasy world tours, sports activities and large theme parks (Kim, Lee, & Jung, 2020). The new technologies also enhance tourism accessibility, and contribute to the protection of heritage (Bogicevic, Seo, Kandampully, Liu, & Rudd, 2019). Furthermore, it has been observed that both emerging technologies have an impact on supply side (Tourism) and demand side (tourist) (Beck et al., 2019).

4. CONCLUSION AND IMPLICATION

This paper defined Halal tourism according the current practices in Halal travel industry. Promising Halal business model could be developed based on the mutual relationship between Halal tourism and Halal entrepreneurship in Halal Travel market. Thus, many opportunities in Halal tourism could be exploited by Halal entrepreneurs as new Halal ventures. These new Halal ventures might introduce Halal tourism product/services; not only for Muslims but also could be for non-Muslim travellers. Furthermore, possible innovative opportunities that would attract Halal entrepreneur's attention in Halal tourism industry are discussed. These opportunities should not be ignored by Halal tourism players to keep Halal travel market in line with rapid world trends. One of these opportunities is new digital platform that is personalized everything to increase the experience of the entire Muslim community; especially Gen Alpha travellers. As a potential Muslim tourist in the coming years, Gen Alpha may have a major effect on the Halal travel industry because G-Alpha will play an essential role in determining the choices and destinations of their family trips.

REFERENCES

- Abboushi, S. (2017). Global Virtual Currency–Brief Overview. *Journal of Applied Business and Economics*, 19(6).
- Abror, A., Patrisia, D., Trinanda, O., Omar, M. W., & Wardi, Y. (2020). Antecedents of word of mouth in Muslim-friendly tourism marketing: the role of religiosity. *Journal of Islamic Marketing*.
- Ahmad, S. Z., Jabeen, F., & Khan, M. (2014). Entrepreneurs choice in business venture: Motivations for choosing home-stay accommodation businesses in Peninsular Malaysia. *International Journal of Hospitality Management*, 36, 31-40.
- Al-Ansi, A., & Han, H. (2019). Role of halal-friendly destination performances, value, satisfaction, and trust in generating destination image and loyalty. *Journal of Destination Marketing & Management*, 13, 51-60.
- Anastasiadou, C., & Vettese, S. (2019). "From souvenirs to 3D printed souvenirs": Exploring the capabilities of additive manufacturing technologies in (re)-framing tourist souvenirs. *Tourism Management*, 71, 428-442.
- Antonopoulos, A. M. (2014). *Mastering Bitcoin: unlocking digital cryptocurrencies*: " O'Reilly Media, Inc. "
- Arbabian, M. E., & Wagner, M. R. (2020). The impact of 3D printing on manufacturer-retailer supply chains. *European Journal of Operational Research*.
- Ayedh, A., Echchabi, A., Battour, M., & Omar, M. (2020). Malaysian Muslim Investors' Behaviour Towards the Blockchain-based Bitcoin Cryptocurrency market. *Journal of Islamic Marketing, forthcoming*
- Battor, M., & Battor, M. (2010). The impact of customer relationship management capability on innovation and performance advantages: testing a mediated model. *Journal of Marketing Management*, 26(9-10), 842-857.
- Battour, M. (2018). Muslim Travel Behavior in Halal Tourism Mobilities, Tourism and Travel Behavior-Contexts and Boundaries: InTech.
- Battour, M. (2019). Halal Tourism: achieving Muslim tourists' satisfaction and loyalty.
- Battour, M., Battor, M., & Bhatti, M. A. (2013). Islamic Attributes of Destination: Construct Development and Measurement Validation, and Their Impact on Tourist Satisfaction. *International Journal of tourism research*, 16 (6), 556-564.
- Battour, M., Battor, M., & Bhatti, M. A. (2014). Islamic attributes of destination: Construct development and measurement validation, and their impact on tourist satisfaction. *International Journal of Tourism Research*, 16(6), 556-564.
- Battour, M., Battor, M. M., & Ismail, M. (2012). The mediating role of tourist satisfaction: A study of Muslim tourists in Malaysia. *Journal of Travel & Tourism Marketing*, 29(3), 279-297.
- Battour, M., Hakimian, F., Ismail, M., & Boğan, E. (2018). The perception of non-Muslim tourists towards halal tourism. *Journal of Islamic Marketing*.
- Battour, M., & Ismail, M. N. (2014). The Role of Destination Attributes in Islamic Tourism. *SHS Web of Conferences*, 12, 01077.
- Battour, M., & Ismail, M. N. (2016). Halal tourism: Concepts, practises, challenges and future. *Tourism Management Perspectives*, 19, 150-154.
- Battour, M., Ismail, M. N., & Battor, M. (2010). Toward a halal tourism market. *Tourism Analysis*, 15(4), 461-470.
- Battour, M., Ismail, M. N., & Battor, M. (2011). The impact of destination attributes on Muslim tourist's choice. *International Journal of tourism research*, 13(6), 527-540.
- Battour, M., Ismail, M. N., Battor, M., & Awais, M. (2017). Islamic Tourism: An Empirical Examination of Travel Motivation and Satisfaction in Malaysia. *Current Issues in Tourism*, 20(1), 50-67. doi:10.1080/13683500.2014.965665
- Battour, M., Rahman, M. K., & Rana, M. S. (2019). The impact of PHTPS on trip quality, trip value, satisfaction and word of mouth. *Journal of Islamic Marketing*.
- Beck, J., Rainoldi, M., & Egger, R. (2019). Virtual reality in tourism: a state-of-the-art review. *Tourism Review*.
- Bhuiyan, A. H., & Darda, A. (2018). Prospects and Potentials of Halal Tourism Development in Bangladesh. *Journal of Tourismology*, 4(2), 93-106.
- Boğan, E., & Sarıışık, M. (2019). Halal tourism: conceptual and practical challenges. *Journal of Islamic Marketing*.
- Bogicevic, V., Seo, S., Kandampully, J. A., Liu, S. Q., & Rudd, N. A. (2019). Virtual reality presence as a preamble of tourism experience: The role of mental imagery. *Tourism Management*, 74, 55-64.
- Böhme, R., Christin, N., Edelman, B., & Moore, T. (2015). Bitcoin: Economics, technology, and governance. *Journal of economic Perspectives*, 29(2), 213-238.
- Chaney, D., Touzani, M., & Ben Slimane, K. (2017). *Marketing to the (new) generations: summary and perspectives*: Taylor & Francis.
- Chatzoglou, P., & Chatzoudes, D. (2018). The role of innovation in building competitive advantages: an empirical investigation. *European Journal of Innovation Management*.
- Choi, Y. R., Lévesque, M., & Shepherd, D. A. (2008). When should entrepreneurs expedite or delay opportunity exploitation? *Journal of Business Venturing*, 23(3), 333-355.
- Cocco, L., Pinna, A., & Marchesi, M. (2017). Banking on blockchain: Costs savings thanks to the blockchain technology. *Future internet*, 9(3), 25.
- Drucker, P. F. (2007). *Innovation and Entrepreneurship (Classic Drucker Collection)*. Paperback.
- El-Gohary, H. (2016). Halal tourism, is it really Halal? *Tourism Management Perspectives*, 19, 124-130.
- Fadahunsi, A., & Kargwell, S. (2015). Social media, consumer behavior and marketing strategy: Implications of "Halal" on Islamic marketing operations. *Journal of Small Business and Entrepreneurship Development*, 3(1), 36-43.
- Fu, H., Okumus, F., Wu, K., & Köseoglu, M. A. (2019). The entrepreneurship research in hospitality and tourism. *International Journal of Hospitality Management*, 78, 1-12.
- George, N. M., Parida, V., Lahti, T., & Wincent, J. (2016). A systematic literature review of entrepreneurial opportunity recognition: insights on influencing factors. *International Entrepreneurship and Management Journal*, 12(2), 309-350.
- Guo, H., Tang, J., Su, Z., & Katz, J. A. (2017). Opportunity recognition and SME performance: The mediating effect of business model innovation. *R & D Management*, 47(3), 431-442.
- Halkias, D., Pizzumo, E., De Massis, A., & Fragoudakis, M. (2014). Halal products and services in the Italian tourism and hospitality industry: brief case studies of entrepreneurship and innovation. *Journal of Developmental Entrepreneurship*, 19(02), 1450012.
- Hall, M. C., & Williams, A. (2019). *Tourism and innovation*: Routledge.
- Hallak, R., Assaker, G., & Lee, C. (2015). Tourism entrepreneurship performance: The effects of place identity, self-efficacy, and gender. *Journal of Travel Research*, 54(1), 36-51.
- Han, H., Al-Ansi, A., Olya, H. G., & Kim, W. (2019). Exploring halal-friendly destination attributes in South Korea: Perceptions and behaviors of Muslim travelers toward a non-Muslim destination. *Tourism Management*, 71, 151-164.
- Henderson, J. (2009). Islamic Tourism Reviewed. *Tourism Recreation Research*, 34(2), 207-211. doi:10.1080/02508281.2009.11081594
- Hernandez-Perlines, F. (2016). Entrepreneurial orientation in hotel industry: Multi-group analysis of quality certification. *Journal of Business Research*, 69(10), 4714-4724.
- Holmén, M., Magnusson, M., & McKelvey, M. (2007). What are innovative opportunities? *Industry and innovation*, 14(1), 27-45.

- Hsieh, R. M., & Kelley, D. J. (2016). The role of cognition and information access in the recognition of innovative opportunities. *Journal of Small Business Management*, 54(sup1), 297-311.
- Idris, J., & Rahman, S. S. A. (2017). Aida Model, Social Media Marketing and Decision to Patronize of Muslim Friendly Hotel. *Journal of Management & Muamalah*, 7(2), 3-15.
- Karia, N., & Asaari, M. H. A. H. (2016). Halal business and sustainability: strategies, resources and capabilities of halal third-party logistics (3PLs). *Progress in Industrial Ecology, an International Journal*, 10(2-3), 286-300.
- Khalek, A. A. (2018). Entrepreneurship and the Halal Wave in Malaysia *Global Entrepreneurship and New Venture Creation in the Sharing Economy* (pp. 191-205): IGI Global.
- Kim, M. J., Lee, C.-K., & Jung, T. (2020). Exploring consumer behavior in virtual reality tourism using an extended stimulus-organism-response model. *Journal of Travel Research*, 59(1), 69-89.
- Komppula, R. (2014). The role of individual entrepreneurs in the development of competitiveness for a rural tourism destination—A case study. *Tourism Management*, 40, 361-371.
- Kuckertz, A., Kollmann, T., Krell, P., & Stöckmann, C. (2017). Understanding, differentiating, and measuring opportunity recognition and opportunity exploitation. *International Journal of Entrepreneurial Behavior & Research*.
- Lee, C., Hallak, R., & Sardeshmukh, S. R. (2016). Innovation, entrepreneurship, and restaurant performance: A higher-order structural model. *Tourism Management*, 53, 215-228.
- Liu, C.-H. (2017). Creating competitive advantage: Linking perspectives of organization learning, innovation behavior and intellectual capital. *International Journal of Hospitality Management*, 66, 13-23.
- Loureiro, S. M. C., Guerreiro, J., & Ali, F. (2020). 20 years of research on virtual reality and augmented reality in tourism context: A text-mining approach. *Tourism Management*, 77, 104028.
- Lowe, R., & Marriott, S. (2012). *Enterprise: Entrepreneurship and innovation*: Routledge.
- Markides, C., & Sosa, L. (2013). Pioneering and first mover advantages: the importance of business models. *Long range planning*, 46(4-5), 325-334.
- Mastercard-CrescentRating. (2019). *GLOBAL MUSLIM TRAVEL INDEX*
Retrieved from <https://www.crescentrating.com/reports/global-muslim-travel-index-2019.html>
- Mastercard-CrescentRating. (2020). *Halal Travel Frontier 2020*. Retrieved from <https://www.crescentrating.com/reports/halal-travel-frontier-2020.html>
- McCrindle, M. (2014). *The ABC of XYZ: Understanding the Global Generations. The ABC of XYZ: Understanding the Global Generations*: Sydney: University of New South Wales Press.
- Miocevic, D., & Morgan, R. E. (2018). Operational capabilities and entrepreneurial opportunities in emerging market firms. *International Marketing Review*.
- Moro, S., Rita, P., Ramos, P., & Esmerado, J. (2019). Analysing recent augmented and virtual reality developments in tourism. *Journal of Hospitality and Tourism Technology*.
- Nifa, F. A. A., Ismail, R. M., & Saad, A. (2017). Development of a sustainable design guideline for eco-industrial halal parks in Malaysia. *Journal of Engineering Science and Technology*, 12.
- O'dwyer, M., Gilmore, A., & Carson, D. (2009). Innovative marketing in SMEs. *European Journal of Marketing*.
- Power, S., Di Domenico, M., & Miller, G. (2017). The nature of ethical entrepreneurship in tourism. *Annals of Tourism Research*, 65, 36-48.
- Rashid, N. R. N. A., Wangbenmad, C., & Mansor, K. A. (2020). Halal Tourism: Lessons for Destination Managers of Non-Muslim Majority Countries. *International Journal of Business and Society*, 21(1), 473-490.
- Rezai, G., Mohamed, Z., & Shamsudin, M. N. (2015). Can halal be sustainable? Study on Malaysian consumers' perspective. *Journal of Food Products Marketing*, 21(6), 654-666.
- Rong, K., Patton, D., & Chen, W. (2018). Business models dynamics and business ecosystems in the emerging 3D printing industry. *Technological Forecasting and Social Change*, 134, 234-245.
- Ryan, C. (2016). Halal tourism. *Tourism Management Perspectives*, 19, 121-123. doi:<http://dx.doi.org/10.1016/j.tmp.2015.12.014>
- Ryan, P. (2017). Smart contract relations in e-commerce: Legal implications of exchanges conducted on the blockchain. *Technology Innovation Management Review*.
- Salaheldeen, M., Battour, M., & Nazri, M. A. (2019). *Halal Entrepreneurship and Its Role in Sustainable Development Goals 2030 (SDGs)*. Paper presented at the International Conference on Dakwah and Islamic Management (IC-DAIM 2019) Malaysia.
- Salindal, N. A. (2018). Halal certification compliance and its effects on companies' innovative and market performance. *Journal of Islamic Marketing*, 0(0), null. doi:10.1108/jima-04-2018-0080
- Sarwar, A., Haque, A., & Yasmin, F. (2013). The usage of social network as a marketing tool: Malaysian Muslim consumers' perspective. *International Journal of Academic Research in Economics and Management Sciences*, 2(1), 93.
- Seraphin, H., & Green, S. (2019). The significance of the contribution of children to conceptualising the destination of the future. *International Journal of Tourism Cities*.
- Situmorang, S. H., Rini, E. S., & Muda, I. (2017). Customer experience, net emotional value and net promoter score on muslim middle class women in medan. *International Journal of Economic Research*, 14(20), 269-283.
- Stone, M. J., Migacz, S., & Wolf E. (2019). Beyond the journey: The lasting impact of culinary tourism activities. *Current Issues in Tourism*, 22(2), 147-152.
- Swan, M. (2017). Anticipating the economic benefits of blockchain. *Technology Innovation Management Review*, 7(10), 6-13.
- Testa, R., Galati, A., Schifani, G., Di Trapani, A. M., & Migliore, G. (2019). Culinary Tourism Experiences in Agri-Tourism Destinations and Sustainable Consumption—Understanding Italian Tourists' Motivations. *Sustainability*, 11(17), 4588.
- Thomas, M. R., & Shivani, M. (2020). Customer Profiling of Alpha. *Ushus Journal of Business Management*, 19(1), 75-86.
- Tootell, H., Freeman, M., & Freeman, A. (2014). *Generation alpha at the intersection of technology, play and motivation*. Paper presented at the 2014 47th Hawaii International Conference on System Sciences.
- Trimbom, S., Li, M., & Härdle, W. K. (2018). Investing with cryptocurrencies-A liquidity constrained investment approach. *Published version: Trimbom, S., Li, M. and WK Härdle (2019) "Investing with Cryptocurrencies—a Liquidity Constrained Investment Approach" Journal of Financial Econometrics*, doi. org/10.1093/jffinec/nbz016.
- Wilson, J. A., & Liu, J. (2010). Shaping the halal into a brand? *Journal of Islamic Marketing*, 1(2), 107-123.
- Wilson, J. A., & Liu, J. (2011). The challenges of Islamic branding: navigating emotions and halal. *Journal of Islamic Marketing*, 2(1), 28-42.
- Yagmur, Y., Ehtiyar, R., & Aksu, A. (2019). Evaluation of halal tourism in terms of bibliometric characteristics. *Journal of Islamic Marketing*.
- Zsamoczky, M. (2018). The digital future of the tourism & hospitality industry. *Boston Hospitality Review*, 6.

THE IMPACT OF STRATEGIC LEADERSHIP ON ACHIEVING JOB SATISFACTION FOR EMPLOYEES IN THE UAE ISLAMIC BANKING SECTOR

SAIF SAEED ALYILEILI

Faculty of leadership and Management Sciences, University Sains Islam Malaysia., Malaysia.

Abstract

This study aims to identify the relationship between strategic leadership and job satisfaction among workers in the UAE Islamic banking sector. The researcher also aims to highlight the relationship between the characteristics of strategic direction and job satisfaction among employees. Data obtained from $n=180$ questionnaires revealed a significant relationship between strategic leadership and job satisfaction among Islamic banks' employees. Besides, strategic leaders also increased the employees' confidence by motivating them to share their valuable opinions to advance their working conditions. The researchers further concluded that leadership in Islamic banks is strategically working to accomplish their organizational goals. They tend to give special consideration to improve employees' working conditions that ultimately help to provide job satisfaction and designated business goals.

Keywords: Strategic leadership, Job satisfaction, Islamic banking

1.0 INTRODUCTION:

The theory of strategic leadership is one of the most effective approaches dealing with management literature as it determines the success and efficiency of the manager's potential or his inefficiency. [1]. Today strategic leaders play a fundamental role in the economic development process. Due to this reason, strategic leadership is one of the essential tactics that organizations use in achieving competitive advantage. Strategic direction is capable of constituting organizational harmony under the designated business criteria [2]. Strategic leadership also plays an active role in small size organizations to achieve their goals, gives them the ability to survive, and adapt to recent environmental changes. Likewise, strategic leadership can influence the employees to achieve the organizational goals and establish a flexible corporate culture to motivate the employees regarding task completion (Al-Murabba, 2008). The potential of an organization depends on workforce capabilities and employees' ability to work. If an organization lacks interest in employees' well-being, it often leads to negative consequences, including job satisfaction among the workforce. Thus, despite there is much consideration regarding organizational management. Still, job satisfaction is one of the most prominent concerns for all (Abbas, 2003: 175).

Addressing the determinants behind job satisfaction can help organizations to design an appropriate work environment and an effective incentive system to increase job performance among leaders and employees [3]. The process of studying both strategic leadership and job satisfaction is of greater significance. The current study aims to highlight the importance and role of strategic leadership and its potential impacts on work performance in the United Arab Emirates Islamic banking sector.[4]

2.0 SCIENTIFIC CONTRIBUTION

The current study deals with a new dimension of strategic leadership for selecting, preparing, and directing the administrative processes in the General Authority for Islamic Affairs and Endowments, in contrast to what previous studies have addressed [5]. This study is of particular significance as it analyzed the strategic role of the administrative leadership, its impact on achieving job satisfaction, and its effectiveness among the employees of the Islamic banking sector in the UAE. This study also provided a theoretical framework covering the topic of strategic leadership, job satisfaction, and performance effectiveness as a pathway for future researchers. This research is a scientific contribution to studying the role of successful strategic leadership in developing the performance of institutions and job satisfaction.

3.0 LITERATURE REVIEW

3.1.1 Leadership & Job Satisfaction:

In the middle of the twentieth century, several studies addressed leadership styles, their effectiveness, role, and impacts, often resulted in conflicting arguments. Despite the attempts to unify the literature, understanding effective leadership is an incomplete task. Therefore, leadership is mainly defined as a practice of authority within a particular professional relationship or group, having two or more members. A leader focuses mostly on directing activities towards group goals achievement as it is commonly attributed to the leadership role. Fiedler believes that leadership is the process of influencing others with joint action, demanding a leader's compatibility to deal effectively with the challenges.

As the definitions of job satisfaction vary due to the diverse approaches highlighted by different researchers, they made many attempts to affirm a special meaning of job satisfaction [11]. For instance, job satisfaction is the psychological feeling of contentment, satisfaction and happiness to satisfy the needs, desires, and expectations with the work and workplace environment. This job satisfaction is achievable through favorable internal and external environmental factors and management patterns. Similarly, Block defines job satisfaction as a result of many experiences associated with work and attributes itself with an individual's appreciation for yield and its management [12]. Job satisfaction is further defined as an outcome of factors related to the job, mainly measured by the individual's acceptance of work with comfort, self-satisfaction, and effectiveness. Job satisfaction is an individual's feeling of happiness and satisfaction, achieved by determining what the individual expects from his work [6].

3.1.2 Dimensions of strategic leadership

The radical change in the third millennium led to a transformation in the leadership structure. Organizations need to pay special consideration to strategic leadership, that led to the emergence of several basic dimensions of relevant leadership style that consists of:

Organizational learning: Strategic leadership aims for change and improvement through sensitive organizational capabilities. To achieve the desired goals, an organization should be aware of the possible challenges and consequences. Awareness is essential for gaining a competitive advantage because it enables an organization to improve its competitive position by avoiding mistakes [13]. Understanding also allows the organization to improve its operations by understanding weaknesses and strengths and looking for the best ways to correct them. (Oliver, 2012: 11). Awareness also enables the organization to improve its operations by understanding weaknesses and strengths and looking for the best ways to correct them. (Oliver, 2012: 11). We can assume that a strategic leader who possesses full knowledge of organizational challenges and strengths is better able to guide and support his workforce in the best possible manner.

Organizational Structure: It is a framework that determines the nature and reality of corporate relationships regarding the plan, authority, points of connection, levels of interaction, and others (Sweis, 2010, 64). The organizational structure is known as the internal pattern of the organization that consists of relationships. Roles exist throughout the organization, and the organizational structure consists of assigning tasks, coordination, and supervision, directed to achieve organizational goals [14]. Here we can assert that a strategic leader who can draw and define the suitable structure of the authority is well-capable of achieving the desired organizational goals.

Administrative Empowerment of Workers: Empowerment is a primary factor in improving administrative proceedings. It is a process that grants autonomy to workers by sharing relevant information with the employees and necessary control over the factors affecting their performance. In simple terms, it is a style that shares leaders' authority with the other members in the decision-making process [15]. We can claim that a strategic leader can inspire individuals through his vision and enables them to participate in policymaking and implementation.

Modern technologies: It is a group of logistical interactions that work to organize the technical skill of the leader, through which the organization interacts internally and externally to facilitate its general performance [16]. Here we assume that the strategic leader who keeps pace with technical progress can lead the authority to develop, change, and interact with the potential competitors.

3.2 The Importance of Job Satisfaction and Strategic Leadership:

Job satisfaction received much attention as the workforce prefers to avail satisfaction through different sources.

Job satisfaction has a more significant influence on employees' personal and professional lives. Job satisfaction leads to increased productivity and other benefits for institutions and workers. As a result, many studies addressed job satisfaction in the field of organizational psychology. Some studies also revealed that functionally satisfied individuals live longer than dissatisfied individuals and are less prone to anxiety, have increased self-esteem, and more generous social adaptability. As there is a positive correlation between job satisfaction and better psychological and physical health [17]. Job satisfaction is of great importance, as it is a measure of effective performance. Higher job satisfaction leads to desirable results as organizations give special consideration to grants, bonuses, and attractive salary packages to their employees. On the contrary, dissatisfaction causes absenteeism, frequent work accidents, delays in work, moving to other institutions, and anti-workplace behavior, which directs them to establish trade unions to defend their interests. As Likert argued, attaining organizational goals become impossible, leading to adverse outcomes [18].

Therefore, job dissatisfaction is one of the most apparent indications of poor working conditions and employees' rights violations [19]. So we assume that:

- ✓ A high level of job satisfaction leads to a higher level of ambition among employees.
- ✓ Individuals with high job satisfaction scores are more satisfied with their free time, especially with their families, as well as more satisfied with life in general.
- ✓ Employees who are more satisfied with their work are less likely to have work accidents.
- ✓ High level of job satisfaction leads to an increased organization performance

In general, employee job satisfaction one of the most critical indicators of department performance and progress. Dissatisfied employees poorly perform and having adverse physical and mental health [20, [21].

4.0 RESEARCH METHODOLOGY

The researcher utilized a quantitative approach as they help to describe results directly gathered from respondents in the form of numbers, frequencies, and percentages [22]. As the quantitative method is one of the fundamental data gathering techniques applied in descriptive studies, it represents a standard model for the steps of collecting data from the participants and presenting data in a well-manipulated manner [24]. Thus the researcher used $n=180$ well-developed, structured questionnaires distributed among the respondents currently working in Islamic banks in the United Arab Emirates.

5.0 RESULTS & DISCUSSION:

5.1 Demographic variables

Table 1: Demographical Data of the Study Respondents

Variable	Factor	Frequency	Percentage
Gender	Male	162	90.7%
	Female	18	9.3%
Marital Status	Single	17	9.5%
	Married	163	90.5%
Work Experience	More than fifteen years	85	46.7%
	Less than ten years	42	23.3%
	Less than five years	40	22.2%

Table 1 above shows the demographical data of the study participants. As seen, $N=162$ or 90% of the participants were males, and $n=18$ or 9.3% were females. Similarly, a majority of respondents ($n=163$ or 90.5%) were married, and $n=85$ or 46.7% of the participants were having work experiences of more than fifteen years in the relevant field, $n=42$ or 23.3% of participants' had less than ten years of experience, and only $n=40$ or 22.2% of participants had less than five years of field experience.

5.2 The Relationship between Strategic Leadership and Job Satisfaction in the Islamic Banks in Emirates:

The first hypothesis aimed to validate the relationship between strategic leadership and job satisfaction among the employees of Islamic banks. Results indicated that all paragraphs of the axis are statistically significant as the relationship between the proposed variable is positive ($\alpha=0.001$). We found that strategic leadership seeks to achieve job satisfaction an average of (4.36). Results also revealed that the strategic leadership aims to achieve employee satisfaction by all available means and methods with the mean value of (4.52), and the highest error value that did not exceed (0.05). We also found that strategic leadership is concerned with the participation of employees in the work plans of the authority. Seeking employees' involvement is one of the most critical characteristics of strategic leadership, having positive impacts on the workflow with an average of (4.37) and an error value (0.05). It is also evident from the results that managers fully cooperate and support the employees with a high average of (4.44) and an error value of no more than (0.05), which contributes to work performance efficiently. Likewise, managers also participate with employees in decisions making a high average of (4.25) and an error value that does not exceed (0.06), which is a democratic management approach. The strategic leadership also provides job satisfaction by improving the employees' performance with an average of (4.43) and an error value that did not exceed (0.05). It is one of the essential pillars of the successful institution that can keep pace with the accelerating scientific developments and revolutions. In this regard, strategic leadership monitors the strengths and weaknesses of employees. It takes care of their physical and psychological needs with a high average of (4.28) and an error value that did not exceed (0.06). This approach contributes to developing practical treatment plans for the employee who suffer from professional inadequacies. Results also indicated that employees' needs and demands strongly impacts leaders with a high degree of (4.11) and an error value that does not exceed (0.06). **Table 1** contains a detailed overview of the results relevant to the first hypothesis.

Table (1): Arithmetic Mean and Standard Deviation

Measuring factors	Arithmetic average	standard deviation	ratio	correlation	sig
Strategic leadership seeks to achieve employee satisfaction.	4.52	0.74	0.05	.858**	0.001
Strategic leadership is concerned with involving employees in the work plans of the banks.	4.37	0.83	0.05	.903**	0.001
Instructs managers in the spirit of cooperation and support among workers.	4.44	0.79	0.05	.831**	0.001
Managers involve employees in making decisions, delegating banks, and taking care of employees' needs and wants.	4.25	0.91	0.06	.896**	0.001
The strategic leadership provides the organizational climate that achieves my satisfaction and performance	4.43	0.75	0.05	.902**	0.001
Strategic leadership encourages competition and innovation at work	4.45	0.77	0.05	.886**	0.001
Strategic leadership studies and considers my strengths and weaknesses	4.28	0.94	0.06	.884**	0.001
The wishes of the employees influence the leader	4.11	0.92	0.06	.697**	0.001
Strategic leadership enhances the capabilities of the authority's employees and supports rehabilitation and Emiratization.	4.38	0.74	0.05	.871**	0.001

5.2 The Influence of Strategic Leadership on Work Performance in the Islamic Banks in Emirates:

The second hypothesis postulated the impact of the strategic leadership on the employees' work performance. Results revealed that all paragraphs of the axis are statistically significant as the relationship between the proposed variable is positive ($\alpha \leq 0.05$). After examining the arithmetic averages, we found that strategic leadership strongly influences employees to work performance with an average of (4.36). We also found that strategic leadership motivates the employees to present new and innovative ideas suitable for work with an average of (4.43), which is the highest value among all values. Likewise, findings also indicated that strategic leadership helps in solving the problems that hamper workflow for employees with an average of (4.41). Removing potential obstacles is one of the essential contributive factors to maintain working activities. Furthermore, the authority also helps the strategic leadership to increase the level of job satisfaction for employees by an average of (4.41), which is the general goal. Similarly, strategic leadership based decisions increase employee satisfaction, such as increasing salaries and incentives, with an average of (4.21). As salary increases and bonus rewards are among the most important motivations that raise employee morale for work loyalty. In this context, we found that the organizational climate at work helps as a mediating factor between employee satisfaction and performance with an average of (4.36). **Table 2** below provides a detailed overview of the relevant results.

Table (2): One-Sample T-test

Measuring factors	Arithmetic average	standard deviation	ratio	T	sig
Leadership motivates employees to provide new and innovative ideas suitable for work.	4.43	0.73	0.05	95	0.000
Strategic leadership helps solve problems in the workflow of employees.	4.41	0.74	0.05	93.12	0.000
Strategic leadership helps in increasing the level of job satisfaction of the employees.	4.41	0.79	0.05	87.35	0.000
Management decisions increase leadership in improving my satisfaction, such as increases in salaries and incentives.	4.21	0.94	0.06	69.94	0.000
Organizational climate helps by acting as a mediating factor between my satisfaction and performance.	4.36	0.74	0.05	91.95	0.000

5.3 Relationship between the Behavior of Strategic Leader and the High Degree of Job Satisfaction:

The third hypothesis intended to authenticate the relationship between the behavior of the strategic leader and the high degree of job satisfaction among employees. The level of significance ($\alpha = 0.001$) and the arithmetic averages validated that the behavior of the strategic leader contributes to a high degree of job satisfaction for the employees with an average of (4.35). The general environment provided by strategic leaders affects achieving satisfaction with an average of (4.33). We also found that work systems, methods, and procedures involve the achievement of satisfaction among employees with a higher value of (4.42). Moreover, Table 3 also shows that job happiness and the sense of accomplishment provided by the strategic leadership has a high degree of (4.31). Furthermore, the results showed the leadership, supervision pattern, the organization's policies, and the methods of its management contribute to achieving employees satisfaction with a high degree of (4.37). Similarly, the relationship between the employees and the strategic leadership also contributes to achieving satisfaction was also very high (4.33).

Table (3): Paragraph Correlation, Mean, and the Standard Deviation

Measuring factors	Arithmetic average	standard deviation	ratio	T	sig
The general environment provided by the strategic leader affects achieving my satisfaction and affects job performance.	4.33	0.78	0.05	.884**	0.001
The work systems, methods, and procedures of the job influence the achievement of employee satisfaction.	4.42	0.68	0.04	.883**	0.001
Affects career happiness and the sense of accomplishment provided by the strategic leadership.	4.31	0.76	0.05	.893**	0.001
The style of leadership and supervision and the organization's policies and management methods contribute to achieving my satisfaction.	4.37	0.79	0.05	.932**	0.001
The relationship between the employee and the strategic leadership contributes to my satisfaction.	4.33	0.77	0.05	.932**	0.001

6.0 CONCLUSION

Strategic leadership is one of the most critical factors that contribute to increased employee performance in Islamic banks. Strategic leaders motivate employees to share their personal opinion, contribute equally in the decision making process, and also tend to solve their workplace problems. As a mediating factor between satisfaction, performance, and managerial decisions, strategic leadership improves the job satisfaction level. The significant differences between strategic leadership and social variables did not influence strategic leadership, as the correlation value for all of them is greater than the $\alpha \geq 0.05$, with the exception of the position of senior management and preachers.

The results of the study showed that strategic leadership is one of the most critical factors that contribute to the high degree of job satisfaction among the employees of Islamic banks in the Emirates. Employee satisfaction has substantial impacts on job performance, and the methods adopted by strategic leaders directly affect the job satisfaction among the employees. Thus the study recommends providing a favorable workplace environment to employees so that they can share their opinions and play an influential role in the decision making process. A favorable workplace environment that will help them to propose creative ideas, and development proposals, that will also, which would lead to achieve an atmosphere of trust and cooperation, raise productivity and develop

work outputs. The recommendation is linked with the study results that can further improve the performance of Islamic banks in the United Arab Emirates.

REFERENCES

- R. Masa' deh, "The role of knowledge management infrastructure in enhancing job satisfaction at Aqaba five star hotels in Jordan," 2016.
- J. Abdulla, R. Djebarni, and K. Mellahi, "Determinants of job satisfaction in the UAE," *Pers. Rev.*, 2011.
- A. K. Al-Swidi, M. K. M. Nawawi, and A. Al-Hosam, "Is the relationship between employees' psychological empowerment and employees' job satisfaction contingent on the transformational leadership? A study on the Yemeni Islamic banks," *Asian Soc. Sci.*, vol. 8, no. 10, p. 130, 2012.
- A. Hassan, A. Chachi, and S. Abdul Latiff, "Islamic marketing ethics and its impact on customer satisfaction in the Islamic banking industry," *J. King Abdulaziz Univ. Islam. Econ.*, vol. 21, no. 1, 2008.
- M. Al-Mahayreh and M. A. Abdel-Qader, "The effect of the factors leading to job satisfaction on the innovation level: study on workers in Islamic banks operating in Jordan," *Int. J. Business, Humanit. Technol.*, vol. 5, no. 1, pp. 24–39, 2015.
- M. Z. Hoq, N. Sultana, and M. Amin, "The effect of trust, customer satisfaction and image on customers' loyalty in Islamic banking sector," *South asian J. Manag.*, vol. 17, no. 1, p. 70, 2010.
- A. B. Abdallah, B. Y. Obeidat, N. O. Aqqad, M. N. K. Al Janini, and S. E. Dahiyat, "An integrated model of job involvement, job satisfaction and organizational commitment: A structural analysis in Jordan's banking sector," *Commun. Netw.*, vol. 9, no. 1, pp. 28–53, 2016.
- S. A. Salloum, M. Al-Emran, R. Khalaf, M. Habes, and K. Shaalan, "An Innovative Study of E-Payment Systems Adoption in Higher Education: Theoretical Constructs and Empirical Analysis," *Int. J. Interact. Mob. Technol.*, vol. 13, no. 6, 2019.
- S. Al-Mohammad, M. Akroush, and A. L. Odetallah, "Marketing culture and business performance," *Mark. Intell. Plan.*, 2014.
- O. Al Muhaisen, M. Habes, and M. Alghizzawi, "An Empirical Investigation the Use of Information , Communication Technologies to English Language Acquisition : A Case Study from the Jordan," *Int. J. Innov. Eng. Sci.*, vol. 7, no. 5, pp. 261–269, 2020.
- S. L. Choi, C. F. Goh, M. B. H. Adam, and O. K. Tan, "Transformational leadership, empowerment, and job satisfaction: the mediating role of employee empowerment," *Hum. Resour. Health*, vol. 14, no. 1, p. 73, 2016.
- L. Tone Hosmer, "The importance of strategic leadership," *J. Bus. Strategy*, vol. 3, no. 2, pp. 47–57, 1982.
- W. M. Al-rahmi, M. S. Othman, and L. M. Yusuf, "Exploring the factors that affect student satisfaction through using e-learning in Malaysian higher education institutions," *Mediterr. J. Soc. Sci.*, vol. 6, no. 4, p. 299, 2015.
- C. Costa, H. Alvelos, and L. Teixeira, "The use of Moodle e-learning platform: a study in a Portuguese University," *Procedia Technol.*, vol. 5, pp. 334–343, 2012.
- S. K. Pandey and G. A. Kingsley, "Examining red tape in public and private organizations: Alternative explanations from a social psychological model," *J. Public Adm. Res. Theory*, vol. 10, no. 4, pp. 779–800, 2000.
- A. Madar, "Quality-a competitive advantage on the hotel services market. Case study: Marriott Hotels & Resort versus Radisson Blu.," *Bull. Transilv. Univ. Brasov. Ser. V Econ. Sci.*, vol. 10, no. 2, 2017.
- C. G.-Q. Chi and H. Qu, "Examining the structural relationships of destination image, tourist satisfaction and destination loyalty: An integrated approach," *Tour. Manag.*, vol. 29, no. 4, pp. 624–636, 2008.
- F. Palumbo, "Developing a new service for the digital traveler," *Internet Encycl. Philos.*, vol. 15, no. August 2014, pp. 1–31, 2015, doi: 10.4192/1577-8517-v15.
- M. Habes, S. A. Salloum, M. Alghizzawi, and M. S. Alshibly, "The role of modern media technology in improving collaborative learning of students in Jordanian universities.," *Int. J. Inf. Technol. Lang. Stud.*, vol. 2, no. 3, 2018.
- A. K. Alhawamdeh, M. Alghizzawi, and M. Habes, "The Relationship Between Media Marketing Advertising and Encouraging Jordanian Women to Conduct Early Detection of Breast Cancer The Relationship Between Media Marketing Advertising and Encouraging Jordanian Women to Conduct Early Detection of Breast Canc," no. May, 2020, doi: 10.7176/EJBM/12-12-11.
- H. Alnawafleh, M. Alghizzawi, and M. Habes, "The impact of introducing international brands on the development of Jordanian tourism," *Int. J. Inf. Technol. Lang. Stud.*, vol. 3, no. 2, 2019.
- M. Habes, M. Alghizzawi, S. A. Salloum, and C. Mhamdi, "Effects of Facebook Personal News Sharing on Building Social Capital in Jordanian Universities," in *Recent Advances in Intelligent Systems and Smart Applications*, Springer, 2020, pp. 653–670.
- M. Habes, "The influence of personal motivation on using social TV: A Uses and Gratifications Approach," *Int. J. Inf. Technol. Lang. Stud.*, vol. 3, no. 1, 2019.
- M. Alghizzawi, M. Habes, S. A. Salloum, M. A. Ghani, C. Mhamdi, and K. Shaalan, "The effect of social media usage on students' e-learning acceptance in higher education: A case study from the United Arab Emirates," *Int. J. Inf. Technol. Lang. Stud.*, vol. 3, no. 3, 2019.

HEADSCARF BAN ON MALAYSIAN HOTEL EMPLOYEES: A WAY FORWARD

Andi Tamsang Andi Kele^a, Sharija Che Shaari^b & Roseni Ariffin^a

Universiti Malaysia Sabah, Malaysia

Abstract

The female labour force in Malaysia, especially in the hotel industry, has increased over the years. Recently, a policy by a few hotels barring Muslim female staff, particularly the frontline, from wearing headscarves has sparked an uproar. Such a ban on headscarves shows cultural and religious insensitivity. The Federal Constitution of the Federation of Malaysia provides that Islam is the official religion in Malaysia, yet there is still a limitation for them to wear the headscarf, which is the symbol of faith for Muslim women. This paper aims to gain an understanding of the underlying reasons for the headscarf ban on Malaysian hotel employees. A phenomenological approach utilising in-depth interviews of 11 stakeholders (hotel employees, hotel owners and human rights institutions employees) was adopted. The findings revealed that managerial prerogative and legal provisions had been identified as themes that influence the stakeholders' perception towards No-headscarf Uniform Policy. There is a dire need for political will to work out satisfactory solutions to some of the problems highlighted above to address the discrimination against employees who wear the headscarf. Hence there must be a concerted effort among the stakeholders to end such discrimination upon women who wear the headscarf in Malaysia

Keywords: Headscarf, Hotel Employees, Malaysia, Managerial Prerogative

1.0 INTRODUCTION

The female labour force in Malaysia has boosted massively over the years. In 1982, there were less than 1.8 million women employed with 44.5% of labour force participation rate and 4.6% of the unemployment rate. In 2017, the number of women employed almost tripled to about 5 million, with 55.2% labour participation rate and 3.3% for the unemployment rate (Labour Force Survey Report, 2017). The hospitality industry is known as a service industry with a significant number of employees to cater to the discerning demand of tourists. Female comprised 48% of the workforce in Hotel, Catering and Tourism in 2008 (Baum, 2012) and the female hospitality workforce was at 55.5% in 2017 (Campbell, 2019).

However, women in the hospitality industry, in particular, must face additional challenges due to the nature of the industry, which is physically exhausting, repetitive, and demands long working hours (Ahmad, Rashid, & Zainol, 2015). It is noted that Muslim women encountered more challenge than other women as most large hospitality businesses provide employee uniforms, and these uniforms hardly comply with the Muslim women dress code. As stated in the Al Qur'an, wearing the headscarf is compulsory to the Muslim women. Veils or headscarf are a woman's most striking signifier of the Muslim religious identity. The headscarf covers the hair, neck, and shoulders.

According to Kele *et al.* (2018), the ban on headscarf worn by Muslim female employee is widely and openly practised by the hotel industry in Malaysia. Malaysian Association of Hotels explicitly defended the "no hijab" policy, or headscarf ban in which is according to the association was consistent with the international standards of hotel operation (Malaysia Insight, 2017). Women who wear headscarf will have a much lower likelihood of employment than non-Muslim women or non-headscarf Muslim women. Muslim women's headscarf continued to be a subject of discussions in the hospitality industry, with the position of headscarf are strongly contested. Despite the growing need, only small number of researches on religious discrimination has taken place (Ghumman & Ryan, 2013) with the majority of the literature focuses on the proper handling of religious discrimination complains (Cromwell, 1997; Ettore, 1996; Kelly, 2008). According to Kele *et al.* (2018), the headscarf is usual to employ the stigmatised individuals and interpersonal discrimination which directed through interpersonal nonverbal behaviour.

It is ironic despite placing Islam as the official religion in Malaysia and the number of Muslim women is increasing in the workplace, there is still limitation for Muslim women who work in hotel industry to wear headscarf. The Constitution of the Federation of Malaysia, being the highest law in the country, has guaranteed that all citizen

is equal before the law. This right is enunciated in Article 8 of the Federal Constitution.

Article 8 (1) that all persons are equal before the law and entitled to its equal protection.

Article 8(2) states: "Except as expressly authorised by this Constitution, there shall be no discrimination against citizens on the ground only of religion, race, descent, gender or place of birth in any law or in the appointment to any office or employment under a public authority or in the administration of any law relating to the acquisition, holding or disposition of property or the establishing or carrying on of any trade, business, profession, vocation or employment."

Apart from the constitutional rights bestowed upon its citizen, Malaysia must ensure that its law adheres to Convention on the Elimination of All Forms of Discrimination against Women (CEDAW). Malaysia has formally acceded to CEDAW since 5 July 1995. The main objective of CEDAW is seeking the elimination of all forms of discrimination against women. By becoming a member to CEDAW, Malaysia is obligated to take all appropriate measures to ensure that all forms of discrimination against women are eliminated with exception to the three reservations. Article 11 of CEDAW requires states parties to "take all appropriate measures to eliminate discrimination against women in the field of employment in order to ensure, on the basis of equality of men and women, the same rights".

From employers' point of view, they require their employees, who directly have guest contact or to the public, to obey to standard grooming, hygiene and appearance standard (Robinson, Franklin, & Hamilton, 2010). This is usually done through a clearly defined dress code policy. Moreover, employers emphasised of the importance of employee appearance to the image of their respective organisations and believe that it is their right to require their employees to meet minimum grooming expectation. Employees are required to be accepted to societal expectations of dress and behaviour in their workplace. Dress code standards are usually challenged due to different treatment on the basis of religion or sex (Robinson, Franklin, & Hamilton, 2010). Employers are aware of the importance that employee appearance has on the image of their particular businesses, but there is an increasing likelihood of having appearance policies and dress codes challenged as religious discrimination (Robinson, Franklin, & Hamilton, 2010). For example, a Muslim woman may request to wear a headscarf as part of her religious practice in her workplace, such as in the hotel. It is thus interesting to determine whether the headscarf is in a Malaysian hotel are discriminated? This study attempts to answer how the differences between the stakeholders pertaining to the religious requirement of employees' dress code could be conciliated.

A recent study on dress code highlights aspects relating to the importance of religion in one's life (Ball and Haque, 2003; Henle and Hogler, 2004) and to seek religious accommodation in the workplace (Morgan, 2004). According to Brotherton (2001) Muslim employees faced the most religious discrimination at work. As work dominates a large portion of an individual's life, separation of one's religious beliefs and the workplace are hard to achieve. The increasing number of religious discrimination lawsuits filed in the United States is a showcase of the lax attitude on the side of the employers in meeting the employees' religious need. Equal treatment of employees by the employers, and to ethically treat employees as well as customers is a necessary step towards ensuring consumer satisfaction and the success of a business (Lattin, 1989; Hall, 1992; Payne and Dimanche, 1996).

Malaysia in 2018 is a vibrant developing and multicultural country, and over the years, Muslim employees in the hospitality industry have increasingly expressed their desire to abide by the Muslim dress code at the workplace. Study implies that employment issues and challenges women face in the labour market are more complex than their male counterparts because of the intertwining of gender with other forms of identity, such as religion and skill (Essers and Benschop, 2009). The significant academic interest mainly focuses to tourism's relationship with Islam; however, less attention was given to understanding the relationship between hospitality and Islam (Stephenson, 2014) As stated by Malaysian Association of Hotels chairman Cheah Swee Hee (Hotels' headscarf ban sparks uproar in Malaysia, 2017), the ban on headscarf in international hotel chains in Malaysia is an international standard operating procedure and not discriminatory. Muslim women have used dress for various purposes such as for modesty, protection, and beautification (Flugel, 1966). For Muslim, the main source, Qur'an, has focused on modesty and beautification, and at the same time, it emphasised dress of piety (Fayyaz, 2014). Apart from that, the attire wear is also associated with the sense of one's self or identity (Flugel, 1966). For example, different classes of society wear a different dress to show their position in society. We also use different uniforms to mention our jobs or institutions. People of different cultures wear different dresses. Besides culture and region where we live, dress code is also determined by the faith we espouse. This way, the dress becomes a symbol of one's religious identity and the modesty associated with it (Fayyaz, 2014).

The issue of the headscarf at the workplace has been the subject of intense debates within Malaysia in recent years. The battles between those wishing to wear clothing that signifies religious belief and those against them can be seen of late in the media platforms (Ho, 2007). Muslim women in Malaysia still face religious discrimination in

the hotel industry, when it comes to the wearing of the headscarf, which is a religious requirement that many of them adhere to. As in any service industry in Malaysia, employees in the international hotel chains and their headscarf do play a crucial role in creating the social dynamics of the hospitality landscape in the country.

2.0 METHOD

A phenomenological approach was adopted in this study to explain the specific and to identify phenomena through how they are perceived by the stakeholders. Information and perceptions are gathered through an inductive, qualitative method of in-depth interviews, discussions and participant observation, and representing it from the perspective of the stakeholders (Lester, 1999; Lincoln & Guba, 2011). Phenomenology is an inductive qualitative research approach that is rooted in the philosophical proposition that researchers can gain valuable insight into the structure of how people understand their experiences (Bliss, 2016). As such, they are powerful for understanding subjective experience, gaining insights into people's motivations and actions, and cutting through the clutter of taken-for-granted assumptions and conventional wisdom. More importantly, phenomenological approaches are good at surfacing deep issues and making voices heard. To explore current practice with respect to dress code in the lights of religious perspective in hotel industry, in-depth, face-to-face interviews were considered the most appropriate method to achieve goals of the explanatory process (Fisher 2007) and enable the researcher to explore, identify and clarify important elements that require in-depth exploration (Sarantakos, 2005).

The phenomenon shapes the method chosen by the researcher and includes the type of participants (Hycner, 1999). Snowball sampling was utilised to identify the primary participants and were selected based on researchers' judgement and the purpose of the study by aiming for those who had experience relating to the phenomenon (Kruger, 1988). Snowballing is a method of expanding the sample by asking one informant or participant to recommend others for interviewing (Babbie, 1995). Greig and Taylor (1999) call those through whom entry is gained gatekeepers and those persons who volunteer as assistance key actors or key insiders. Researchers requested the participants to give, at their choice, the names and contact details of persons based in industry or government who were co-responsible for the phenomenon. In order to ensure ethical research, an informed consent agreement was acquired (Holloway, 1997). The informed consent agreement form was explained to subjects at the beginning of each interview. Most potential subjects signed the agreement and those who did not were not pressured to participate in the study. All who ended up being participants were in agreement with its content and signed.

Since Boyd (2001) regards two to ten participants or study subjects as adequate to reach saturation and Creswell (1998) recommends in-depth interviews with up to 10 people for a phenomenological study is enough. Therefore, 11 stakeholders consisting of 7 hoteliers, one representative of the hotel association, one representative of the labour union and two representatives of the government were interviewed in this study (refer to Table 1). The interviews lasted approximately 45-60 minutes and were audio-recorded with noted transcribe for data coding. The purpose of collecting data from three different kinds of informants is a form of triangulation. Data-collection interviews continued until the topic was exhausted or saturated, that is when participants introduced no new perspectives on the topic.

Table 1. In-dept Interview Participant Characteristics

No	Pseudonyms	Position	Hotel	Profile of Informants
1	Siti	Hotel Executive	3-star hotel, independent hotel	Female, around 25, Muslim
2	Edy	Hotel Manager	4-star hotel, chain hotel	Male, 37, Muslim
3	Elly	Hotel Executive	4-star hotel, independent hotel	Female, around 25, Muslim
4	Dana	Hotel Director	5-star hotel, independent hotel	Female, around 50, revert-Muslim
5	Ann	Hotel Manager	4-star hotel, independent hotel	Female, 35, Muslim
6	Din	Hotel Manager	5-star hotel, international chain hotel	Male, 35, Muslim
7	Zue	Hotel Manager	4-star hotel, international chain hotel	Female, around 50, Muslim
8	Lim	Manager	Hotel Association	Male, around 40, non-Muslim
9	Gerald	Manager	Human Rights Institution	Male, around 50, non-Muslim
10	Shafie	Manager	Labour Union	Male, around 40, Muslim
11	Ali	Manager	Ministry of Human Resource	Male, around 40, Muslim

Schurink, Churink and Poggenpoel (1998) emphasise the truth-value of qualitative study and list a number of means to achieve truth. In this study, the phenomenological research design contributed toward truth. Researchers consciously in order to understand, in terms of the perspectives of the participants interviewed the phenomenon that was studied. The audio recordings made of each interview and the transcription of the interview further contributed to the truth. Thereafter participants received a copy of the text to validate that it reflected their perspectives regarding the phenomenon that was studied. The findings of the completed study are presented next.

3.0 RESULT AND DISCUSSION

3.1 Managerial Prerogative

The stakeholders believe that the dress code is solely their managerial prerogative. The employer, in principle, can come up with a dress code of their own and job applicant who had accepted the job offer should adhere to it, including rules on the wearing of the headscarf.

Angel: In the beginning, the management views this as a very sensitive issue and prohibit me from discussing this issue... but at the same time, they never rejected my request as well. So, when my staff in the back office requested to wear the headscarf, I just approved because it is sad for me to see them taking off their headscarf when they are working... After sometimes, the management realises that this does not affect the hotel's operation and no complaints from other employees or guests, so they just silently approve my decisions... and the back-office staff can wear headscarfs since then...

Even hotels under the same management company may have different acceptance toward employees wearing headscarf due to leader intervention. A human resource manager confirmed that:

Peter: For H Hotel in Kota Kinabalu, we do not really allow all staff to wear the headscarf. But, in H Hotel Kuala Lumpur, they do allow the back-office staff to wear headscarf... this is because, in Kuala Lumpur, the turnover rate is high and if they stick with the no headscarf rule, it is hard for them to keep up with the competition to get and retain the staff, so the management in Kuala Lumpur changes their practices... we face a similar challenge but not as severe as them, so we still continue our current practices.

The management of the hotel in Malaysia are faced with a diverse and complicated range of employee's dimensions such as age, sexuality, disability and religious affiliation. Diversity management is "a process of management built on a set of values, which recognise that the differences between people are a potential strength for the organisation" (De Cieri & Kramar, 2005: 248). In hindsight harnessing workforce differences; in this case, the headscarf will create a productive environment in which everyone is valued, and their talents are fully utilised to achieve organisational objectives. It is important for management to recognise that conducive and positive workplace experiences are not only shaped by organisational and/or legal contexts but also by religious bargains based on multiple roles and cultural values.

Although both hotels shared the brand and are managed by the same company in the same country, due to different environment and challenges faced, they applied different strategy, and the leader has the power to make the call to make necessary changes. It is undeniable that hoteliers enjoy prerogatives to decide what is best for their business survival. However, such prerogatives must not be at the expense of those who would like to practice their religious beliefs and teachings. It is put forth that the hotelier especially international hotel chain would stick to the current dress code until and unless the management is headed by a person who understands the values in religious teachings (Islam to be more specific). Hence, discrimination against employees wearing headscarf will continue.

As the number of headscarf-wearing workforce in Malaysia is booming, it is sufficient to say that hotel management will not be able to tap the full potential of good employees from the existing pool of talents. The headscarf is not a fashion statement to most wearers but a religious requirement that needs to be observed and guided. There are many instances that when the headscarf requirement over time has not been fulfilled by the management, employees would imminently leave the organisation. Conciliation between employees' demand headscarf, management prerogative, and macro-level structures collectively account for power uniformity and advantage within the society and Malaysia employment contexts at large. Although the wearing of a headscarf is a religious obligation, the decision lies in the hands of the job applicant whether they could adhere to the company's policy. Thus, striking a balance between the employers and employees is a challenge to the HR manager.

3.2 Legal Provisions

No headscarf policy is not aligned with Malaysia's predominant religion Islam, where Muslims comprise approximately 60% of Malaysia population. When a Muslim is being denied for wearing headscarf either to work or any other activities outside the confine of her house, it is synonym as to deny her the right to practice Islam (Ho, 2007). When the international hotel chains in Malaysia ban headscarf at the workplace, it shows disrespectful and intolerant towards the Malaysian culture and religious needs of its people. Such hotels demonstrate an ill understanding of the country and reflect poorly on their credibility, diversity and equality international policy.

Since there's no plausible explanation from the hotels as to why the headscarf is a hindrance to the nature of the wearer's work, the solution to the issues must be sought out. Continuous dialogue and immersive understanding of the local social and religious need would conciliate the wider acceptance and inspiration of the local populace. Goodwill and respect will generate positive work culture and best suit the famous country tagline, "Malaysia Truly Asia". Conciliating the differences based on trust, tolerance and long known history of respect among Malaysian would be most appropriate.

Article 3 of the Federal Constitution states that Islam is the religion of the Federation. Although legal provisions uphold the position of Islam, they are not intended to recognise Malaysia as an Islamic state. Legal provisions in Malaysia, in terms of Federal and State laws, appear to justify the need for Islam to be given a higher status than other religions based on the historical factors of Islamic law in Malaya, the recognition of Islam as the Federal religion and other provisions that must be interpreted in harmony with Islamic law. Apart from recognising Islam as the official religion of the Federation, the Federal Constitution upholds that it is a citizen's right to practice his/her religious belief. Article 11 of the Federal Constitution of Malaysia states that every individual has the right to profess, practice and preach his religion or belief.

As with other rights of basic freedom, freedom of religion, which covers the right to profess, practice and propagate religious teachings as well as to administer religious affairs, is not an absolute right. The contentious issue here is as to whether religious freedom would cover all aspects of practice as far as the said religion is concerned. This is due to the fact that in respect of religion, every person has three rights: to profess; to practice; and subject to Clause 4, to propagate his religion.

Practise means to put into practice, to perform, to carry out, to do habitually. Although this is how the word "practise" is understood, it is important to note that in Malaysia it has been held by the courts that freedom of religion extends only to those practices and rituals that are essential and mandatory. In *Hjh Halimatussaadiah bte Hj Kamaruddin v Public Service Commission Malaysia & Anor* (1994) 3 MLJ 61. The issue was whether a female Muslim public servant could wear purdah to work. The apex court was of the view that the government was entitled, "in the interest of the public service", to forbid the wearing of a Niqab while in the workplace was not considered to curtail the religious practice. In this case, the apex court was in the opinion that wearing purdah in the workplace should be banned for the sake of public security. Furthermore, wearing purdah was a religious tradition that was non-essential and optional. The same reasoning applied in *Fatimah Sihi & Ors v Meor Atiqulrahman bin Ishak & Ors*, where Muslim schoolboys failed to get court endorsement of their demand to wear serban to school.

The above cases exemplified that the court in Malaysia did not tolerate any religious practice/tradition that has gone beyond or excessive. The prohibition is only in relation to Niqab and serban because these practices are non-essential. Islamic teachings do not place the needs to put on Niqab and Serban. It is up to the individual to go an extra mile to put on niqab and serban, should they opt to do so. However, it is a basic Islamic principle of modesty which is outlined in the Quran. There are Quran verses and hadiths, which deals with the issue of decency and headscarf.

زَيِّنْتُهُنَّ بِبِدِينٍ وَلَا جُبُوبِهِنَّ عَلَىٰ بُحْمِهِنَّ وَأَلْبُسُهُنَّ مِمَّا ظَهَرَ مَا إِلَّا زَيَّنْتُهُنَّ بِبِدِينٍ وَلَا فُرُوجِهِنَّ وَبِحِفْظِنَ أَبْصَارِهِنَّ مِنْ بَعْضِصُنَّ لِلْمُؤْمِنَاتِ وَقُلْ أَيْمَانَهُنَّ مَلَكَتْ مَا أَوْ نِسَائِهِنَّ أَوْ َاخَوَاتِهِنَّ بَنِي أَوْ إِخْوَانِهِنَّ بَنِي أَوْ إِخْوَانِهِنَّ أَوْ تِهِنَّ َعُولِ أُنْبَاءِ أَوْ إِبْنَاتِهِنَّ أَوْ بُعُولَتِهِنَّ أَبَاءِ أَوْ آبَائِهِنَّ أَوْ لِبُعُولَتِهِنَّ إِلَّا زَيَّنْتُهُنَّ مِنْ خَفِيِّنَّ مَا لِيُعْلَمَ بِأَرْجُلِهِنَّ يَصْرِبْنَ وَلَا النِّسَاءِ وَرَاتِ عَ عَلَىٰ يَظْهَرُوا لَمْ الَّذِينَ الطِّفْلِ أَوْ الرِّجَالِ مِنَ الزُّبَّةِ أُولِي غَيْرِ التَّابِعِينَ أَوْ
24:31 - تَقْلِحُونَ لَعَلَّكُمْ الْمُؤْمِنُونَ إِلَيْهِ جَمِيعًا اللَّهُ إِلَىٰ وَتُؤْبُوا

"And tell the believing women to reduce [some] of their vision and guard their private parts and not expose their adornment except that which [necessarily] appears thereof and to wrap [a portion of] their headcovers over their chests and not expose their adornment except to their husbands, their fathers, their husbands' fathers, their sons, their husbands' sons, their brothers, their brothers' sons, their sisters' sons, their women, that which their right hands possess, or those male attendants having no physical desire, or children who are not yet aware of the private aspects of women. And let them not stamp their feet to make known what they conceal of their adornment. And turn to Allah in repentance, all of you, O believers, that you might succeed." (An-Nur:31)

The above verse highlights three aspects; that a woman shouldn't show her beauty except when faced with uncontrolled factors, like the wind blowing her clothes; that the headscarf should cover the hair, neck, and the bosom; and that women need not cover up in front of certain men (husbands, fathers, sons, etc).

In another verse, Allah gives the following command to Prophet Muhammad:

...جَلَابِيهٍ مِّنَ عَلَيْهِنَ يُدْنِينَ: الْمُؤْمِنِينَ نِسَاءً وَ بَنَاتِكَ وَ لِأَزْوَاجِكَ قُلْ، النَّبِيُّ أَيُّهَا يَا

"O Prophet! Say to your wives, your daughters, and the women of the believers that: they should let down upon themselves their jalabib" (al-Ahzab:59)

A woman's body should be covered such that only her face, hands, and feet are revealed. Thee clothing should cover their hair and body, but covering the face and the hands, from the wrist to the fingers, is not mandated. Secondly, the clothing must be loose enough so that the shape of a woman's body is not visible. Muslim women are not permitted to wear tight and revealing clothing; especially the ones showing the details of their body.

There are many reasons whether a Muslim female would choose to put on a headscarf or not. The decision to cover or not is a personal and known only to the respective female. If the Muslim female chooses to put on headscarf at her workplace, thus she should not be discriminated for practising her religious belief. Hence, no employer should indiscriminately bar Muslim female employee from wearing the headscarf at the workplace.

However, the contentious issue here is the female employees in the hotel industry are prohibited from practicing their basic religious belief. The practices in the hospitality industry, which do not allow the staff to wear the headscarf are leading to the headscarf is to stay away from the industry. For those Muslim females who are currently working in the hotel (not wearing a headscarf), they will face a dilemma should they decide to wear the headscarf. They may fear the employer's negative response or they may have to leave their current position.

At present, there is no statutory provision pertaining to the wearing or non-wearing of headscarf at Malaysian workplaces (Borstorff, & Arlington, 2011). As it is, the Malaysian government entirely leaves the issue of the dress code to the respective employers. It is regarded as the managerial prerogative to formulate the dress code that suits the company. In Malaysia, there are three statutes that govern minimum terms and conditions enjoyed by an employee which are segregated to the region. For the employee in Peninsular Malaysia, the Employment Act 1955 is applicable to those who fall within the definition of "employee" in its First Schedule. Whilst for Sabah and Sarawak, Sabah Labour Ordinance and Sarawak Labour Ordinance will be applicable to Sabah and Sarawak respectively. These statutes do not provide any protection against discrimination in the workplace. The two court cases above mentioned are confined to the practices which are non-essential. So far, there is no case law pertaining to discrimination due to putting on headscarf at the workplace.

The Federal Constitution of Malaysia prohibition against discrimination is only applicable to laws and public authorities. However, the deliberate discrimination faced by the headscarf-wearing workers in the private sector is a strong reminder to the sector to imbue within itself the Constitutional spirit. It is highly timely that the Employment Act should be amended and hotels guilty of restricting the headscarf should have their licenses revoked. For the employee in Peninsular Malaysia, the Employment Act 1955 is applicable to those who fall within the definition of "employee" in its First Schedule. Whilst for Sabah and Sarawak, Sabah Labour Ordinance and Sarawak Labour Ordinance will be applicable to Sabah and Sarawak respectively. These statutes do not provide any protection against discrimination at the workplace. Thus, the Ministry of Human Resources must act promptly to put a stop to the overall unwarranted and damaging approach to Islam by the private sector.

The proposed legislative measure would criminalise and hence provide legal aid for those who were discriminated. Conciliation process on the part of industry players and the legislative arms of the government must take place so that the discrimination based on religion, race, gender and other forms of discrimination at work could finally be prevented.

4.0 CONCLUSION

There is no known legal action taken against religious workplace discrimination and hiring practices in any hotels in Malaysia. Discriminatory hiring practices in Malaysia include not only banning the headscarf for the Muslim employees but also employment advertisements calling for 'Mandarin speakers' only, despite Bahasa Malaysia being the primary language of communication in Malaysia. Article 8(1) and Article 8(2) in The Constitution of the Federation of Malaysia has guaranteed that all citizens are equal before the law. Besides, Malaysia is also a member of the Convention on Elimination of all Forms of Discrimination Against Women (CEDAW), whose main objective is to protect and safeguard women's rights in the country.

The highest law of the land is seen as 'toothless' if hotels in Malaysia continue to practice a ban on the headscarf not only with their existing employees but preventing all together with the potential employees that don the headscarf even before they were called for the job interview. The shape of politics in contemporary Malaysia and the constitutive definition of politics is essential in addressing not only hierarchical relations of domination and subordination of a country but also a clear direction for a country identity and sovereignty.

It may safely be concluded that freedom of religion under the Malaysian Federal Constitution cannot be understood without making reference, especially to Articles 3 and 11 of the Federal Constitution. Hence, a proper understanding of these Articles is essential while faced with the issue or question of religious freedom from a Malaysian perspective. There is also a need to understand other constitutional provisions related to the discussion of religious freedom as far as the Malaysian Federal Constitution is concerned. However, it is wholly admitted that by understanding these constitutional provisions alone would not solve the problems that we are currently facing in the context of freedom of religion. Thus, there is a dire need for political will to work out satisfactory solutions to some of the problems highlighted above if we were to really address the discrimination against the Employees wearing headscarf. It is obviously tricky to handle the issue on discrimination upon Employees wearing headscarf in Malaysia. Hence there must be a concerted effort among the stakeholders to end such discrimination upon Employees wearing headscarf in Malaysia

The hotel management and those of similar position must be sensitive to their employees' needs to uphold their religious beliefs, in this case, the wearing of a headscarf. Good faith application of these obligations by the employer should preclude the necessity for governmental intervention, regardless of the country in which the employer does business. However, there is no easy fix to the existing headscarf ban and discrimination at the international hotels in Malaysia. Like any other industries, systematic review and monitoring must be observed and carried out in earnest. A standard operating procedure (SOP) to assist employees and employers for all hotels in the country should be introduced. SOPs aim to achieve efficiency and uniformity policies on the headscarf, while reducing miscommunication and failure to comply with government regulations. Continuous monitoring of the SOP will safeguard that only one standard procedure is to be used across the country.

Conflict is an inevitable aspect of social change. Parties to conflicts, for most cases, tend to view their interests as entirely opposed. The possible outcomes are seen to be win-lose, both lose or both win situation. The scale of the headscarf conflict outcomes amongst all the stakeholders may well be wider than conflicts suppose. The conciliation process if initiated by the policymaker, implies a strong assertion of all parties' interest in line with the aspirations and needs of all stakeholders.

The new ruling government of Malaysia, which was formed after the 14th General Election should view that all discrimination based on religion and gender, will not be tolerated. The controversy surrounding international hotel chains policy banning the headscarf for Muslim women at workplace in Malaysia or any form of Islamophobia has to be addressed amicably especially in a country which holds Islam as the religion of the Federation. The act of banning the headscarf has been pushed to the centre of Malaysia political discourse. It is very timely for the policymaker to craft a legislative measure that outlaws all forms of religious discrimination.

All in all, it is submitted that the efforts at the societal level may be more fruitful in understanding the notion of freedom of religion under the Malaysian Federal Constitution. Thus, freedom of religion may be enshrined in the Malaysian Constitution, but Malaysians have much to learn about respecting one another's faith. Also, although religion is often viewed as a sensitive issue, society should not be afraid to discuss it in a peaceful and tactful manner. What is important in the discussion of freedom of religion in a Malaysian context is for us to strike a balance between being tactful and tolerant with religious issues, and at the same time, be open to allow individuals to practice their religious beliefs.

All authors are required to complete the IBMC exclusive license transfer agreement before the article can be published, which they can do online. This transfer agreement enables IBMC to protect the copyrighted material for the authors, but does not relinquish the authors' proprietary rights. The copyright transfer covers the exclusive rights to reproduce and distribute the article, including reprints, photographic reproductions, microfilm or any other reproductions of similar nature and translations. Authors are responsible for obtaining from the copyright holder, the permission to reproduce any figures for which copyright exists.

ACKNOWLEDGEMENTS

This project is financially supported by the University Malaysia Sabah Research Grant Scheme (SGPUMS-SPLB) SLB0140-2017

REFERENCES

- Ahmad, R., Rashid, B., & Zainol, N. A. (2015). Career Performance of Muslim Female Bachelor of Hospitality Management Graduates. *Academic Research International*, 6(3), 75-85.
- Babbie, E. (1995). *The practice of social research* (7th ed.). Belmont, CA: Wadsworth.
- Ball, C., & A. Haque. (2003, Fall). Diversity in religious practice: Implications of Islamic values in the public workplace. *Public Personnel Management*, 32(3) 315-330.
- Baum, T., (2012). International Perspectives on Women and Work in Hotels, Catering and Tourism, Bureau for Gender Equality Working Paper 1/2013, Sectoral Activities Department Working Paper No. 289, Geneva: ILO.
- Bliss, L. A (2016). Phenomenological Research: Inquiry to Understand the Meanings of People's Experience. *International Journal of Adult Vocational Education and Technology*. Vol 7 (3) 14- 18 DOI: 10.4018/IJAVET.2016070102
- Borstorff, P., & Arlington, K. (2011). Protecting Religion In The Workplace? What Employees Think. *Journal of Legal, Ethical and Regulatory Issues*, 14(1), 59-70.
- Boyd, C.O. 2001. Phenomenology the method. In P.L. Munhall (Ed.), *Nursing research: A qualitative perspective* (3rd ed., pp. 93-122). Sudbury, MA: Jones and Bartlett
- Brotherton, P. (2001, March/April). Religious diversity initiatives foster respect and understanding. *Mosaics*, 7, 1- 4.
- Creswell, J. W. (1998). *Qualitative inquiry and research design: Choosing among five traditions*. Thousand Oaks, CA: Sage.
- Cromwell, J.B., (1997). Cultural Discrimination: The Reasonable Accommodation of Religion in The Workplace. *Employee Responsibility and Rights Journal*, 10 (2): 155-172.
- De Cieri, H., & Kramar, R. 2005. *Human resource management in Australia*. Sydney: McGraw-Hill.
- Essers, C., & Benschop, Y. 2009. Enterprising identities: Female entrepreneurs of Moroccan and Turkish origin doing boundary work. *Human Relations*, 62(3): 403-425.
- Ettorre, B. (1996) Religion in the Workplace: Implications for Managers. *Management Review*, 85(120), 15-18.
- Fayyaz, W., & Kamal, A. (2014). Practicing headscarf (veil): A Source of Autonomy and Self-esteem for Modern Muslim Women. *Journal of Humanities & Social Sciences*, XXII, (1), 19-34.
- Flugel, J. C. (1969). *The Psychology of Clothes*. New York International Universities Press
- Ghumman, G., & Ryan, A.M. (2013) Not Welcome Here: Discrimination Towards Women Who Wear The Muslim Headscarf. *Human Relations*, 66 (5) 671-698.
- Greig, A., & Taylor, J. (1999). *Doing research with children*. London: Sage.
- Hall, S. S. J.: 1992, *Ethics in Hospitality Management: A Book or Readings* (Educational Institute of the American Hotel & Motel Association, East Lansing, MI).
- Henle, C.A., & R. Hogler. (2004). The duty of accommodation and the workplace religious freedom act of 2003: From bad policy to worse law. *Labor Law Journal*, 55-165.
- Ho, C. (2007). Muslim women's new defenders: Women's rights, nationalism and Islamophobia in contemporary Australia. *Women's Studies International Forum*, 30: 290-298.
- Holloway, I. (1997). *Basic concepts for qualitative research*. Oxford: Blackwell Science.
- Hotels' headscarf ban sparks uproar in Malaysia. (2017, November 13). Retrieved from <https://www.todayonline.com/world/asia/hotels-headscarf-ban-sparks-uproar-malaysia>.
- Hycner, R. H. (1999). Some guidelines for the phenomenological analysis of interview data. In A. Bryman & R. G. Burgess (Eds.), *Qualitative research* (Vol. 3, pp. 143-164). London: Sage.
- International Labour Organization (2016) Women at Work. Retrieved https://www.ilo.org/wcmsp5/groups/public/---dgreports/---dcomm/---publ/documents/publication/wcms_457317.pdf
- Kele, A.T.A., Shaari, S.C., Ariffin, R., & Stephen, S.G., (2018) Old Wine in the New Bottle: Dress Code in Malaysia Hotels. *International Journal of Engineering & Technology*, 7 (4.38), 1563-1566.
- Kelly, E. (2008) Accommodating Religious Expression in The Workplace. *Employee Responsibility and Rights Journal*, 20 (1): 45-56.
- Kruger, D. (1988). *An introduction to phenomenological psychology* (2nd ed.). Cape Town, South Africa: Juta.
- Labour Force Survey Report (2017) Department of Statistics Malaysia. Retrieve <https://www.dosm.gov.my/v1/index.php?r=column/pdfPrev&id=aEdlelhVTBtOHhOUxqcXhvc2pCUT09>
- Lattin, G. W.: 1989, *The Lodging and Food Service Industry* (2nd ed.) Educational Institute of the American Hotel and Motel Association, East Lansing, MI).
- Lester, S. (1999). *An introduction to phenomenological research*. Stan Lester Developments, Taunton. <http://www.sld.demon.co.uk/resmethy.pdf>
- Lincoln, Y.S. Lynham, S.A. and Guba, E.G. (2011) *Paradigmatic Controversies, Contradictions, and Emerging Confluences*, Revisited, *The Sage Handbook of Qualitative Research*, (2011)
- Morgan, J. (2004). How Should business respond to a more religious workplace? *SAM Advanced Management Journal*, 69(4), 11-19.
- Payne, D., & Dimanche, F. (1996). Towards a Code of Conduct for the Tourism Industry: An Ethics Model. *Journal of Business Ethics*, 15(9), 997-1007.
- Robinson, R. K., Franklin, G.M., & Hamilton, R. H. (2012). The Headscarf and the Kufi: Employer Rights to Convey Their Business Image Versus Employee Rights to Religious Expression. *Southern Law Journal*, Vol XXII, 79-88.
- Sarantos, S. (2005) *Social Research*. 3rd, Hampshire: Palgrave Macmillan.
- Schurink, W. J., Schurink, E. M. & Poggenpoel, M. (1998). Focus group interviewing and audiovisual methodology in qualitative research. In A. S. De Vos (Ed.), *research at grass roots, a primer in care professions*. Pretoria, South Africa: Van Schaik.
- Stephenson, M. L. (2014). Deciphering "Islamic Hospitality": Developments, Challenges and Opportunities. *Tourism Management*, 40, 155-164.

TAHAP KEFAHAMAN TERHADAP KONSEP KESEDERHANAAN DALAM PENGGUNAAN: APAKAH FAKTOR PENENTUNYA?

Auna Najiah Ahmad, Mohd Ali Mohd Noor & Hairunnizam Wahid

Fakulti Ekonomi dan Pengurusan, Universiti Kebangsaan Malaysia

Abstrak

Kes individu diisytiharkan bankrap atau muflis yang semakin meningkat saban hari menjadi persoalan. Bagaimana perkara ini terus berlaku dan apakah yang menyebabkan situasi sebegini menjadi perkara yang membimbangkan. Berdasarkan kaedah persampelan secara rawak mudah yang melibatkan seramai 160 orang responden di sekitar negeri Selangor yang terdiri dari kaum Melayu yang beragama Islam telah dipilih untuk menjawab soal selidik yang diedarkan secara atas talian. Soal selidik dibentuk dengan melaksanakan ujian realibiliti dengan menganalisis kesahan dan kebolehpercayaan instrumen menggunakan pekali kebolehpercayaan *Cronbach's alpha* bagi memperoleh hasil dapatan yang boleh dipercayai. Proses menganalisis data kajian dilakukan dengan menggunakan perisian *Statistical Package for Social Science (SPSS)*. Analisis deskriptif dijalankan pada bahagian kedua dalam soal selidik bagi mengetahui tahap kefahaman masyarakat di negeri Selangor. Hasil dapatan kajian menunjukkan prestasi memuaskan dengan hasil 63.1 peratus iaitu sebanyak 101 orang responden yang faham terhadap konsep kesederhanaan dalam penggunaan. Selain itu, kajian ini juga bertujuan mengenal pasti faktor yang mempengaruhi tahap kefahaman seseorang individu dari perspektif demografi, tahap pendidikan, pekerjaan sampingan dan seterusnya menentukan faktor yang paling signifikan menyumbang kepada tahap kefahaman seseorang individu. Kajian menggunakan model logit binomial untuk menguji pemboleh ubah yang dipilih terhadap tahap kefahaman. Keputusan daripada analisis ekonometrik menunjukkan faktor status kahwin dan pekerjaan sampingan adalah signifikan mempengaruhi tahap kefahaman terhadap konsep kesederhanaan dalam penggunaan. Justeru, isi rumah dan individu muslim haruslah peka dengan isu dan keadaan sekeliling dengan ilmu pengetahuan yang perlu dicari serta bijak dalam menguruskan wang bagi mengelakkan masalah hutang isi rumah dan kes individu muflis terus meningkat.

Kata Kunci: *Tahap kefahaman; kesederhanaan dalam penggunaan; model logistik*

1.0 PENGENALAN

Pengguna Islam sebagaimana pengguna lain umumnya berhadapan dengan persoalan bagaimana menggunakan pendapatan untuk memenuhi keperluannya dengan cara yang boleh memberi kepuasan maksima. Akan tetapi pengguna Islam mempunyai nilai dan sikap yang berbeza jika dibandingkan dengan pengguna konvensional. Perbezaan sedemikian wujud kerana pengguna Islam berkelakuan mengikut tuntutan iman berpandukan kepada kehendak agama. Perbezaan sikap ini membawa perubahan kepada objektif penggunaan, penentuan titik optimum kepuasan dan keluk permintaan barang (Sanep Ahmad, 2017).

Tambahan lagi, pengguna Islam adalah *Islamic man* bukan *economic man*. Pengguna Islam akan berbelanja dan menggunakan pendapatannya berdasarkan kepada tiga prinsip penggunaan yang utama iaitu kekayaan sebagai amanah, kejayaan melalui keridaan Allah SWT dan balasan hari akhirat (Kahf 1981:22). Ini bermakna pengguna dipandu berdasarkan kebenaran dan yang hak oleh Allah SWT. Segala sesuatu adalah pada hakikatnya milik Allah dan harta yang dimiliki perlu dibelanjakan dengan cara yang bertepatan dengan peraturan Allah SWT seperti yang dinyatakan dalam Al-Quran, “dan milik Allah segala apa yang ada di langit dan dibumi...” (surah Al-Imran, 3:129, an-nisa, 4:131).

Berdasarkan dalil lain di dalam al-Quran Surah Al-Jathiyah, ayat ke 18 “Kemudian kami jadikan engkau (wahai Muhammad) menjalankan satu jalan (syariat) yang cukup lengkap dari hukum agama, maka turutilah jalan itu dan janganlah engkau menurut hawa nafsu orang-orang yang tidak mengetahui”. Oleh itu, Islam sangat menggalakkan supaya umat Islam bersikap bersederhana dalam apa jua keadaan tidak kira dalam aspek pemakanan, berbelanja, penggunaan air, elektrik, tenaga, masa dan sebagainya.

Walaupun begitu, dewasa ini, kebergantungan masyarakat terhadap hutang amat membimbangkan (Nurshahirah et. al., 2013). Dapat dilihat di sini bahawa kefahaman terhadap konsep kesederhanaan dalam masyarakat Islam di Malaysia tidak selari dengan gelagat perbelanjaan dan penggunaan yang dipamerkan oleh masyarakat Islam itu sendiri. Situasi ini lebih membimbangkan apabila melihat kepada statistik yang dikeluarkan oleh Jabatan Insolvensi Malaysia terhadap kes bankrap yang terjadi di Malaysia.

Menurut Jabatan Insolvensi Malaysia (2013) sebanyak 18,179 kes bankrap telah didaftarkan dengan purata lebih kurang 50 kes setiap hari. Kes kebangkrutan menunjukkan kaum Melayu adalah yang paling ramai diisytiharkan mufliis, iaitu sebanyak 11,498 kes yang mewakili 52 peratus daripada jumlah bankrap 2013. Manakala selebihnya terdiri daripada kaum Cina (29%), India (14%) dan lain-lain kaum (4%) (Toto Ngadiman et al., 2019).

Walaubagaimanapun, sejak 2014 hingga 2018 sebanyak 56,058 daripada 95,105 jumlah kes bankrap yang direkodkan telah dibebaskan daripada status orang bankrap. Statistik Jabatan Insolvensi Malaysia (Mdl), merekodkan Selangor menduduki tangga teratas negeri paling banyak kes bankrap iaitu 24,648 kes sepanjang tempoh empat tahun diikuti Wilayah Persekutuan Kuala Lumpur (11,774) serta Johor (10,796). Berdasarkan umur pula, mereka yang berusia 35 hingga 44 tahun paling banyak bankrap iaitu 32,948 orang diikuti 24,584 orang yang berusia 45 hingga 54 tahun, manakala 25 hingga 34 tahun pula adalah seramai 23,577. Data itu juga menunjukkan punca kebangkrutan yang paling tinggi adalah 26,399 pinjaman peribadi, 23,521 sewa beli kenderaan manakala pinjaman perumahan sebanyak 13,400 dan 9,428 hutang kad kredit.

Menurut Lea et al. (1995) individu yang berpendapatan rendah sering dikaitkan dengan hutang. Ini adalah kerana mereka terpaksa berhutang bagi memenuhi keperluan asas dan mendapatkan barangan daruriyyat. Namun begitu, terdapat bukti (Zuroni et. al., 2010) bahawa isi rumah meminjam bukan untuk memenuhi keperluan tetapi mengikut kehendak yang menerangkan kesan kepada peningkatan hutang isi rumah di Malaysia. Peningkatan hutang juga berlaku disebabkan oleh perbelanjaan mewah dalam mendapatkan barangan tahsiniyyat semata-mata untuk meningkatkan harga diri mereka. Dengan mengubah cara hidup seperti bergaya dengan barangan mewah dan bersosial dengan golongan hidup mewah dan kaya menjadikan seseorang itu kelihatan kaya. Seseorang yang mempunyai harga diri yang rendah akan berusaha untuk meningkatkannya. Perkara ni telah dibuktikan dalam kajian yang dijalankan oleh (Nur et. al. 2017) yang menunjukkan bahawa berhutang dapat meningkatkan harga diri seseorang. Senario ini telah mempengaruhi gelagat perbelanjaan dalam barangan tahsiniyyat melalui pinjaman dan seterusnya akan mempengaruhi masyarakat dalam menambahkan pinjaman dengan berhutang.

Selain itu, latar belakang seseorang juga mungkin mempengaruhi gaya hidup individu tersebut seperti kawasan tempat tinggal seperti luar bandar atau di bandar, tahap pendidikan, pekerjaan dan sebagainya. Latar belakang yang pelbagai akan mempengaruhi kefahaman seseorang individu seterusnya akan menzahirkan sifat sama ada dia akan sentiasa bersederhana dalam apa jua keadaan ataupun terus menerus membazir dan tidak berjimat-cermat. Banyak lagi faktor-faktor lain yang mempengaruhi kefahaman terhadap konsep kesederhanaan dalam penggunaan.

2.0 KAJIAN LEPAS

Definisi kesederhanaan telah banyak dibincangkan sama ada dari konsep kesederhanaan dan dari sudut istilah mengikut pakar-pakar dalam ekonomi dan juga dalil-dalil dari al-quran dan hadis. Perbincangan dan kajian berkaitan kesederhanaan, kepenggunaan dan juga berkaitan kesederhanaan dalam penggunaan juga sudah banyak dibahaskan. Namun begitu, melihat kepada status kebangkrutan yang dikeluarkan oleh Jabatan Insolvensi Malaysia (2019) menunjukkan rekod masih terdapat kes bankrap atau mufliis saban tahun telah menjadi tanda tanya pengkaji apakah rakyat Malaysia khususnya di Selangor masih belum ada kesedaran terhadap situasi ini.

Pengguna Islam sebagaimana pengguna lain umumnya berhadapan dengan persoalan bagaimana untuk menggunakan pendapatan yang dapat memenuhi keperluan dengan cara yang boleh memberikan kepuasan maksima (Sanep Ahmad, 2017). Walaubagaimanapun, pengguna Islam mempunyai nilai dan sikap yang berbeza berbanding pengguna konvensional. Ini adalah kerana, pengguna Islam mempunyai garis panduan yang telah ditunjukkan dalam al-quran dan sunnah dalam menguruskan kehidupan seharian mereka. Perbezaan nilai dan sikap ini membawa perubahan kepada kegiatan pengeluaran, pengagihan dan penggunaan (Razak & Mohd Dali, 2012) dan seterusnya akan menentukan sejauh mana tahap kefahaman mereka dalam mempraktikkannya.

Sejak Amerika Syarikat mengamalkan Reaganomics, dunia telah beralih arah dengan menjalani kehidupan secara mewah dengan berhutang. Kajian yang telah dijalankan oleh Nur et. al. (2017) jelas menyatakan bahawa responden dalam kalangan kaum Melayu membuat pinjaman adalah disebabkan untuk membeli kenderaan, pinjaman peribadi, rumah kediaman dan kad kredit. Tambahan lagi, purata keseluruhan gelagat hidup bermewah bagi semua kaum adalah tinggi iaitu sebanyak 62.4 peratus. Cara hidup sebegini menunjukkan bahawa mereka tidak memahami konsep kesederhanaan dan seterusnya mendorong untuk berhutang dalam memberi kepuasan

dalam kehidupannya. Oleh itu, kajian ini wajar dijalankan bagi melihat apakah faktor yang menjadi penentu kepada tahap kefahaman individu terhadap konsep kesederhanaan ini.

Kesejahteraan dalam konteks ekonomi barat iaitu dengan membuat pengukuran apabila seseorang individu dapat memenuhi kehendaknya semata-mata. Pandangan ini jelas sekali bertentangan dengan kehendak Islam kerana nilai etika dalam ekonomi Islam ialah dengan cara mengurangkan keperluan manusia terhadap kebendaan yang berlebihan dan mengutamakan dalam soal kerohanian (Razak & Mohd Dali, 2012). Selain itu, pengkaji bersetuju dengan pendapat yang dikemukakan dalam buku yang ditulis oleh Anas Zubedy (2019) berkaitan dengan 10 Prinsip Kesederhanaan Rakyat Malaysia. Penulis menyatakan bahawa rakyat Malaysia seharusnya mengamalkan gaya hidup yang sederhana dalam perbelanjaan, tabiat pemakanan dan cara berpakaian kita. Jika kita mahu menjadi individu yang baik, maka jangan sesekali biarkan sifat tamak menguasai diri kita. Ini adalah kerana rakyat Malaysia itu sendiri menjadi manifestasi kesederhanaan dan hakikatnya kitalah agen kesederhanaan itu.

Apabila berbincang tentang penggunaan, maka tidak dapat elak dengan masalah kebergantungan individu dalam berhutang. Kebanyakan orang memahami bahawa berhutang akan memberi kesan buruk dalam kehidupan seseorang. Oleh itu, pengkaji membahaskan aspek berhutang dengan terperinci. Keburukan atau implikasi negatif terhadap sikap berhutang tidak dapat dinafikan tetapi sebagai orang Islam yang mempunyai dua sumber yang diimani iaitu al-Quran dan hadis perlu terlebih dahulu melihat berkaitan dengan keperluan berhutang dan sikap orang yang berhutang mengikut syariat Islam. Perkara ini dilihat seperti Islam menggalakkan berhutang dan sikap ini seperti satu sikap yang negatif. Walhal, maksud yang lebih terperinci belum difahami dengan sebaiknya. Sebagai orang Islam kita perlu faham dan ingat dengan janji Allah s.w.t. iaitu pelepasan dari kesusahan di akhirat bagi orang yang menyelesaikan masalah saudaranya yang ditimpa kesusahan di dunia. Dalam sabda Nabi Muhammad s.a.w. yang diriwayatkan oleh Abu Hurairah yang bermaksud;

“Sesiapa yang menyelesaikan kesusahan saudaranya di dunia, Allah akan melepaskan kesusahannya pada hari kiamat kelak”.

(Riwayat al-Tarmizi)

Berbalik kepada item dalam soal selidik kajian ini iaitu bagi item negatif (*saya sanggup berhutang untuk mendapatkan barangan keperluan*) diberikan markah (1) untuk sangat tidak setuju dan (5) untuk sangat setuju. Markah yang diberikan adalah bertentangan dengan item negatif lainnya kerana melihat kepada konsep keperluan berhutang mengikut syariat Islam iaitu seseorang yang ingin berhutang mestilah mempunyai hajat dan keperluan mendesak bukannya untuk bermewah. Oleh itu, bagi mereka yang berhutang atas sebab untuk mendapatkan barangan keperluan dan keadaan mendesak adalah dibenarkan berdasarkan dalil yang telah dibentangkan. Melihat kepada kajian yang dijalankan oleh Abdul Basit Hodori et al. (2014) sebab utama mereka berhutang adalah untuk memenuhi keperluan dan tanggungjawab kepada rumah tangga seperti tempat tinggal, kenderaan, pendidikan anak-anak yang masih kecil dan juga kos sara hidup yang semakin meningkat. Perkara ini disokong oleh kajian Ab Rahim et al. (2012) bahawa Islam membenarkan umatnya berhutang atas sebab keperluan sahaja dan orang yang berhutang tersebut perlu bertanggungjawab dalam membuat pembayaran semula apabila tiba masanya.

Tambahan lagi, ramai dalam kalangan umat Islam tidak memahami maksud dari hadis Nabi dengan sebaiknya di mana ulama menyaksikan bahawa Rasulullah itu adalah orang yang cukup atau bersederhana dalam hidupnya. Nabi juga sebenarnya menginginkan pengikutnya memiliki harga diri, kuat dan semangat bekerja dan bukan orang lemah yang miskin segala-galanya baik fizikal mahupun mental (Siregar 2013). Apa yang digambarkan dari sikap Nabi ini juga turut dikaji oleh Toto Ngadiman et al. (2019) iaitu berkenaan dengan harga diri. Kepentingan harga diri tidak boleh dipandang enteng kerana ia memberi kesan kepada tingkah laku dan cara berfikir seseorang. Dengan adanya harga diri juga dapat membantu secara langsung dalam memperoleh kejayaan. Oleh sebab itu, Nabi sangat menggalakkan umatnya mempunyai harga diri. Walaubagaimanapun, hasil dapatan dari kajian Toto Ngadiman et al. (2019) mendapati bahawa terdapat hubungan yang signifikan antara harga diri dengan niat untuk meningkatkan pinjaman. Selain itu, kajian ini juga mendapati bahawa mereka yang berpendapatan rendah turut membelanjakan pendapatan mereka dalam barangan tahsiniiyyat. Dapat dirumuskan di sini bahawa semangat Nabi menginginkan pengikutnya mempunyai harga diri tetapi dengan cara membelanjakan pendapatan secara bersederhana dan berpatutan mengikut keperluan diri.

Melihat kepada hasil dapatan dari kajian-kajian terdahulu berkenaan dengan sikap berhutang di kalangan rakyat Malaysia amnya, salah satu kemungkinan yang menyebabkan situasi ini berlaku adalah kerana kurangnya ilmu dan kefahaman terhadap konsep kesederhanaan. Oleh itu, pengkaji tertarik untuk menjalankan kajian ini bagi meneliti apakah faktor-faktor yang mempengaruhi tahap kefahaman seseorang individu terhadap konsep kesederhanaan dalam penggunaan. Memahami dan mengaplikasikan makna sebenar terhadap konsep kesederhanaan dalam penggunaan adalah agak sukar bagi seorang manusia yang dikawal dengan akal dan nafsu. Penggunaan merangkumi pelbagai aspek yang perlu diambil kira iaitu penggunaan dalam fungsi perbelanjaan,

pemilihan barangan, pemakanan, penggunaan air dan elektrik, masa, tenaga, alam semula jadi dan lain-lain lagi.

Perbincangan yang utama adalah melihat kepada aspek perbelanjaan seharian dan dalam pemilihan barangan. Definisi kepada berbelanja iaitu menggunakan wang untuk mendapatkan sesuatu barangan yang mempunyai nilai. Sebagai pengguna kita semestinya berkehendak kepada barangan yang berkualiti dan pada masa yang sama harga yang ditawarkan adalah murah. Tetapi situasi ini jarang sekali kita lihat di pasaran kerana barangan yang berkualiti kebiasaannya akan meletakkan harga yang tinggi setimpal dengan keadaan, fungsi dan kesan kepada penggunaan barangan tersebut. Kenyataan ini disokong dengan kajian yang telah dijalankan oleh Panatik (2004) yang menyatakan bahawa faktor kesempurnaan merupakan faktor yang paling tinggi mempengaruhi gaya pembuatan keputusan pembelian barangan di kalangan pengguna. Faktor kesempurnaan yang dimaksudkan dalam kajian tersebut ialah kesedaran terhadap kualiti yang tinggi. Oleh itu, dapat dilihat di sini bahawa pengguna kebanyakannya akan melihat kepada barangan yang berkualiti tinggi walaupun harga yang diletakkan juga adalah tinggi. Walaupun begitu, ia bertentangan dengan dapatan kajian M. Saifoul et al. (2014) bahawa persepsi pengguna terhadap harga mempunyai kesan besar kepada pengaruh masyarakat untuk berbelanja. Walaupun kajian tersebut dijalankan dengan mengambil kira jenama Malaysia yang harganya agak murah berbanding dengan jenama lain, tetapi keputusan dari kajian ini juga menunjukkan bahawa persepsi terhadap kualiti barangan adalah sederhana atau tidak berbeza dengan jenama lain. Dengan kata lain, responden dalam kajian ini memilih barangan berdasarkan harga kerana barang dan kualiti yang sama boleh diperolehi dengan harga yang lebih murah. Oleh yang demikian, Islam sangat menggalakkan umatnya untuk bersederhana dalam berbelanja iaitu dengan cara yang berhemah. Pengguna seharusnya menilai sesuatu barangan atau perkhidmatan berdasarkan kepada harga dan kualiti yang mana dapat memberikan yang munasabah mengikut kehendak pengguna tersebut.

Seterusnya, tingkah laku dalam perbelanjaan dalam pemakanan juga adalah kesan utama dalam membentuk sejauh mana individu mempraktikkan apa yang mereka fahami dari konsep kesederhanaan. Umum mengetahui bahawa makanan merupakan elemen penting sebagai pembekal nutrisi dalam tubuh badan manusia bagi kelangsungan hidup manusia. Berdasarkan firman Allah dalam al-Quran yang bermaksud;

“...makan serta minumlah, dan jangan pula kamu melampau. Sesungguhnya Allah tidak suka orang-orang yang melampau batas”

(al-A'raf:31)

Dapat kita fahami dari makna dalam ayat al-Quran ini bahawa sebagai umat Islam kita tidak dibenarkan untuk berlebih-lebihan dalam makan dan minum. Oleh itu, pengkaji menekankan sekali lagi bahawa dalam memahami makna kesederhanaan dalam aspek pemakanan ialah dengan membuat perbelanjaan secara sederhana setakat mencukupi sahaja dan tidak sesekali melakukan pembaziran yang akhirnya boleh merosakkan alam ini.

Begitu juga perlu difahami peranan air dan elektrik yang menjadi sumber utama dalam kehidupan seharian sebagai manusia di muka bumi ini. Sumber air dan elektrik adalah sumber terpenting yang mesti diambil kira dalam menilai tahap kefahaman terhadap konsep kesederhanaan seseorang individu. Semua benda hidup yang diciptakan Allah di atas muka bumi ini termasuklah manusia itu sendiri memerlukan air untuk terus hidup. Manusia hanya akan mengerti kepentingan air dan elektrik jika mereka tidak boleh dapatkan dengan cara yang mudah. Sebagai contoh, apabila bekalan air dan elektrik terputus, maka kita dengan sedaya upaya akan cuba untuk menggunakan sumber ini dengan paling minimum. Dapat dilihat di sini, betapa berharganya nilai air walaupun setitik jika kita memahami akan kepentingannya. Begitu juga nilai bagi sumber elektrik yang menghasilkan pelbagai kemudahan dalam kehidupan seharian (Zuroni et. al., 2016). Salah satu item yang ditanya dalam soal selidik bagi kajian ini iaitu berkenaan dengan penggunaan air. Pertanyaan ini diajukan bagi mendapatkan hasil kajian berkaitan dengan tahap kefahaman masyarakat Selangor terhadap konsep kesederhanaan. Melihat kepada krisis air di Lembah Klang yang saban tahun menjadi isu dan permasalahan bagi rakyat Selangor adalah disebabkan oleh perbuatan manusia itu sendiri (Ahmad Zaharuddin, 2004). Oleh itu, pengkaji tertarik untuk menjalankan kajian bagi menilai tahap kefahaman terhadap konsep kesederhanaan dalam penggunaan air oleh masyarakat di negeri Selangor. Walaubagaimanapun, dalam menilai sejauh mana tahap kefahaman masyarakat Selangor terhadap konsep kesederhanaan dalam penggunaan, seharusnya melihat kepada apakah faktor penentu yang memberi kesan dalam mereka memahami konsep ini. Berkemungkinan seseorang individu melakukan pembaziran dalam penggunaan bukan disebabkan diri mereka sendiri, tetapi adalah disebabkan faktor-faktor lain seperti tahap pendidikan, taraf perkahwinan, pendapatan bulanan, pekerjaan dan sebagainya. Persoalannya, apakah faktor-faktor ini boleh mempengaruhi tahap kefahaman seseorang dan adakah ia mempengaruhi secara signifikan? Persoalan tersebut akan dijelaskan dalam kajian ini.

3.0 METODOLOGI KAJIAN

Kajian ini menggunakan pendekatan kuantitatif dengan menggunakan kaedah soal selidik sebagai instrumen kajian. Soal selidik diedarkan kepada 160 orang responden secara atas talian. Pengkaji menggunakan kaedah persampelan secara rawak mudah kepada masyarakat di Negeri Selangor. Soal selidik dalam kajian ini terbahagi kepada 2 bahagian. Bahagian pertama adalah set soalan demografi berkaitan dengan latar belakang responden dan bahagian kedua pula berkenaan dengan sejauh mana tahap kefahaman masyarakat Selangor terhadap konsep ini. Sebelum soal selidik diedarkan, pengkaji menjalankan analisis kesahan dan kebolehpercayaan item soal selidik dengan menggunakan analisis realibiliti atau ujian kebolehpercayaan. Kaedah ini digunakan untuk mengetahui kesahan instrumen soal selidik untuk dijadikan bahan kajian.

Pada set soal selidik bahagian pertama menggunakan respon aneka pilihan jawapan. Item yang dinyatakan adalah untuk mengukur faktor-faktor yang mempengaruhi tahap kefahaman terhadap konsep kesederhanaan dalam penggunaan. Bagi mendapatkan hasil dapatan responden bagi bahagian ini, pengkaji menggunakan kaedah analisis statistik deskriptif melalui aplikasi *Statistical Package for the Social Sciences* (SPSS). Manakala, pada bahagian kedua pula, item respon skala likert digunakan bagi merumuskan tahap pemahaman responden terhadap konsep kesederhanaan dalam penggunaan. Item ini dibangunkan dan diadaptasi berdasarkan kepada kajian (Almenberg et al., 2018) yang dikenalpasti bersesuaian dengan soalan mengenai kesanggupan dalam membuat perbelanjaan tahsiniyyat. Ukuran bagi item-item tersebut telah dijalankan dengan menggunakan Skala Likert lima mata, bermula dari (1) sangat tidak setuju hingga (5) sangat setuju.

Bahagian kedua soal selidik dibahagikan kepada 2 bentuk soalan iaitu item berbentuk positif dan item berbentuk negatif. Kedua-dua item ini dianalisis menggunakan analisis korelasi pearson bagi mengetahui adakah terdapat hubungan yang signifikan antara kedua-dua item tersebut. Seterusnya data pada bahagian kedua ini dianalisis menggunakan analisis regresi logistik untuk melihat kebarangkalian individu memahami terhadap konsep kesederhanaan dalam penggunaan. Pemboleh ubah bersandar dalam kajian ini berbentuk diktomus iaitu sama ada faham atau tidak faham terhadap konsep kesederhanaan dalam penggunaan. Memandangkan pemboleh ubah bersandar berbentuk diktomus dan pemboleh ubah bebas yang digunakan kebanyakannya berbentuk dami maka model ini sesuai dianggarkan dengan menggunakan model logit binomial (Gujarati & Dawn, 2009). Model yang akan dianggarkan (Hairunnizam et al. 2005) secara umumnya adalah seperti berikut:

$$P_i = E(Y = 1/X) = 1 / (1 + e^{-m}) \quad (1)$$

di mana:

P_i adalah kebarangkalian bagi responden yang memahami iaitu $Y = 1$ dan $Y = 0$ bagi responden yang tidak memahami.

Persamaan (1) boleh ditulis dalam bentuk berikut:

$$P_i = 1 / (1 + e^{-m}) = e^m / (1 + e^m) \quad (2)$$

Jika P_i adalah kebarangkalian bagi responden yang memahami konsep kesederhanaan dalam penggunaan iaitu $Y = 1$ maka kebarangkalian bagi responden tidak memahami ialah $Y = 0$ iaitu bersamaan $(1 - P_i)$. Oleh itu kebarangkalian tidak memahami ialah :

$$(1 - P_i) = 1 / (1 + e^m) \quad (3)$$

Oleh itu nisbah kebarangkalian untuk responden faham konsep kesederhanaan adalah dalam persamaan (4) iaitu :

$$P_i / (1 - P_i) = e^m \quad (4)$$

Dengan mengambil natural log bagi persamaan (4) maka akan mendapat persamaan (5) iaitu :

$$\begin{aligned} L &= \ln (P_i / (1 - P_i)) = \ln (e^m) \\ &= M_i \\ &= f(X) \end{aligned} \quad (5)$$

Berdasarkan persamaan (5) kajian ini juga menguji beberapa pemboleh ubah yang dipertimbangkan mempengaruhi kefahaman terhadap konsep kesederhanaan dalam penggunaan iaitu:

$$M_i = \beta_0 + \beta_1 X_1 + \beta_2 X_2 + \beta_3 X_3 + \dots + \beta_i X_i \quad (6)$$

Di mana M_i adalah satu fungsi $f(X)$ dengan X adalah pemboleh ubah bebas yang dipertimbangkan iaitu jantina, umur, taraf perkahwinan, taraf pendidikan, kawasan tempat tinggal, pendapatan isi rumah bulanan dan pekerjaan sampingan. Oleh itu, berpandukan kepada persamaan (6), model khusus yang akan dianggarkan dalam kajian ini ialah:

$$L = \ln(P_i / (1 - P_i)) = \beta_0 + \beta_1 X_1 + \beta_2 X_2 + \beta_3 X_3 + \beta_4 X_4 + \beta_5 X_5 + \beta_6 X_6 + \beta_7 X_7 \quad (7)$$

Di mana :

L	adalah log bagi nisbah 'odds' kefahaman
X1	adalah dami jantina; = 1 untuk lelaki, 0 untuk perempuan
X2	adalah dami umur; = 1 untuk bawah 40 tahun, 0 untuk atas 40 tahun
X3	adalah dami taraf perkahwinan; = 1 untuk berkahwin, 0 untuk tidak berkahwin
X4	adalah dami taraf pendidikan; = 1 untuk berpendidikan tinggi, 0 untuk tidak berpendidikan tinggi
X5	adalah dami kawasan tempat tinggal; = 1 untuk di bandar, 0 untuk luar bandar
X6	adalah dami jumlah pendapatan isi rumah; = 1 untuk bawah RM4,360, 0 untuk RM4,360 ke atas
X7	adalah dami pekerjaan sampingan; = 1 untuk kerja sampingan, 0 untuk tidak melakukan kerja sampingan

Purata umur bagi 160 responden dalam kajian ini adalah 40 tahun dengan responden paling tua berumur 60 tahun manakala responden termuda berumur 20 tahun. Oleh itu, dami ditetapkan dengan nilai 1 bagi umur di bawah 40 tahun dan 0 untuk umur atas 40 tahun. Selain itu, bagi jumlah pendapatan isi rumah pula, kebanyakan responden yang menjawab soal selidik kajian ini memperoleh pendapatan RM4360 ke bawah, iaitu seramai 101 orang mewakili 63.1% daripada jumlah responden. Selebihnya seramai 59 orang responden (36.9%) memperoleh pendapatan RM4,360 ke atas. Oleh itu, dami ditentukan iaitu nilai 1 bagi pendapatan di bawah RM4,360 dan 0 untuk pendapatan RM4,360 ke atas. Pemboleh ubah jumlah pendapatan isi rumah ini digunakan memandangkan ia merupakan salah satu pemboleh ubah yang penting mempengaruhi corak perbelanjaan individu (Toto Ngadiman et al. 2018). Faktor-faktor lain seperti jantina, umur, taraf perkahwinan dan sebagainya juga turut dikaji untuk menguji sejauh manakah ia signifikan mempengaruhi tahap kefahaman seseorang terhadap konsep kesederhanaan dalam penggunaan.

Seterusnya, pemboleh ubah kerja sampingan juga diambil kira sebagai salah satu pemboleh ubah tidak bersandar. Berdasarkan kajian yang telah dijalankan oleh Baba et al. (2018) dan Suhaila et al. (2016) menyatakan bahawa dalam kalangan responden mereka melakukan kerja sampingan adalah disebabkan oleh faktor masalah kewangan. Faktor ini memberi kesan kepada corak perbelanjaan individu tersebut yang mana akan menghasilkan impak terhadap kefahaman terhadap konsep kesederhanaan itu sendiri.

Pemboleh ubah bersandar adalah bernilai 1 jika responden memperoleh skor faham terhadap konsep kesederhanaan dan sebaliknya ia memberi nilai 0 jika responden memperoleh skor tidak faham. Kesemua pemboleh ubah dalam persamaan (7) diuji untuk menentukan manakah pemboleh ubah yang signifikan mempengaruhi tahap kefahaman terhadap konsep kesederhanaan dalam penggunaan.

4.0 HASIL KAJIAN

4.1 Profil responden

Soal selidik yang diedarkan mempunyai 22 item yang dibahagikan kepada dua bahagian iaitu bahagian A dan bahagian B. Bahagian A terdiri daripada 9 item yang berkaitan dengan latar belakang responden manakala bahagian B pula terdiri daripada 13 item yang dibahagikan kepada 2 bentuk iaitu item yang berbentuk positif dan negatif di mana masing-masing terdiri daripada 7 dan 6 item. Soalan ini dibentuk untuk menilai tahap kefahaman masyarakat di negeri Selangor terhadap konsep kesederhanaan dalam penggunaan.

Seterusnya, penganalisan profil demografi responden melibatkan 150 orang responden dianalisis menggunakan statistik deskriptif (Toto Ngadiman et al. 2019) sebagaimana ditunjukkan dalam Jadual 1.

Jadual 1. Profil Demografi Responden

Item	Kekerapan	Peratus (%)
Jantina		
Lelaki	56	35
Perempuan	104	65
Umur		
Bawah 20 Tahun	7	4.4
20 - 30 Tahun	120	75.0
31 - 40 Tahun	14	8.8
41 - 50 Tahun	12	7.5
51 - 60 Tahun	6	3.8
Atas 60 Tahun	1	.6
Status Kahwin		
Bujang	90	56.3
Kahwin	66	41.3
Janda	2	1.3
Duda	2	1.3
Kelayakan Akademik		
SPM	10	6.3
Sijil Diploma	7	4.4
Ijazah Sarjana Muda	48	30.0
Ijazah Sarjana	75	46.9
PHD	16	10.0
PHD	4	2.5
Kawasan Tempat Tinggal		
Bandar	96	60
Pinggir Bandar	23	14.4
Luar Bandar	41	25.6
Pendapatan Isi Rumah		
Kurang RM4,360	101	63.1
RM4,360 – RM9,619	46	28.7
Lebih RM9,619	13	8.1
Kerja Sampingan		
Ya	71	44.4
Tidak	89	55.6

Daripada 160 orang responden yang mengambil bahagian dalam kajian ini, sebanyak 65% adalah perempuan dan selebihnya adalah lelaki. Manakala, dari aspek umur pula, kategori umur 20 tahun hingga 30 tahun adalah majoriti dalam kajian ini iaitu sebanyak 75% (120 orang) berbanding kategori umur yang lain iaitu umur antara 31 hingga 40 tahun sebanyak 8.8% (14 orang), umur 41 hingga 50 tahun sebanyak 7.5% (12 orang), umur di bawah 20

tahun sebanyak 4.4% (7 orang), umur 51 hingga 60 sebanyak 3.8% (6 orang) dan umur melebihi 60 tahun hanya 0.6% (1 orang). Golongan bujang adalah merupakan golongan yang paling ramai iaitu sebanyak 56.3% (90 orang), diikuti oleh golongan yang telah berkahwin iaitu sebanyak 41.3% (66 orang), dan golongan duda atau janda yang memperoleh bilangan responden yang sama banyak iaitu 1.3% melibatkan 2 orang responden. Semua responden yang mengambil bahagian dalam kajian ini adalah beragama Islam dan bumiputera. Dari segi tahap pendidikan pula, hampir separuh dari responden memiliki ijazah sarjana muda sebanyak 46.9% (75 orang) diikuti oleh responden yang memiliki diploma sebanyak 30% (48 orang), ijazah sarjana pula sebanyak 10% (16 orang), SPM 6.3% (10 orang), manakala yang memiliki sijil dan pendidikan di peringkat tertinggi iaitu PHD masing-masing sebanyak 4.4% (7 orang) dan 2.5% (4 orang).

Penempatan responden juga diambil kira dalam kajian ini. Lebih dari separuh responden menetap di kawasan bandar iaitu sebanyak 60% (96 orang), diikuti oleh responden yang menetap di kawasan pinggir bandar iaitu sebanyak 14.4% (23 orang) manakala sebanyak 25.6% (41 orang) yang menetap di kawasan luar bandar. Dari segi kategori pendapatan bulanan pula, tahap pendapatan kurang daripada RM4,360 adalah paling ramai iaitu merangkumi 63.1% (101 orang) diikuti oleh tahap pendapatan antara RM4,360 hingga RM9,619 sebanyak 28.7% (46 orang) manakala pendapatan yang lebih daripada RM9,619 sebanyak 8.1% (13 orang). Dari segi kerja sampingan pula, sebanyak 44.4% (71 orang) responden melakukan kerja sampingan dan sebanyak 55.6% (89 orang) responden tidak melakukan kerja sampingan.

4.2 Ujian Kebolehpercayaan

Ujian kebolehpercayaan bermaksud kebolehan sesuatu alat ukur atau sumber kajian menghasilkan keputusan yang tekad dan konsisten setiap kali pengukuran dilakukan. Ujian kebolehpercayaan perlu dilakukan sebelum instrumen dikemukakan dalam kajian sebenar. Ini adalah kerana ujian ini akan menentukan kebolehpercayaan dan menjamin kualiti item dalam soal selidik dan data yang diperolehi. Ujian ini juga penting untuk dilaksanakan terlebih dahulu

kerana ia dapat memastikan bahawa data yang diperoleh oleh pengkaji adalah data yang tepat dan dapat menjawab kesemua persoalan kajian yang telah digariskan oleh pengkaji Lily et.al (2018).

Dalam kajian ini, pengkaji merujuk kepada pekali kebolehpercayaan *Cronbach's Alpha* untuk mengukur kebolehpercayaan item-item di dalam soal selidik. Nilai kebolehpercayaan ini dirujuk dalam model pengukuran yang biasa digunakan berdasarkan True Score Test Theory (TSTT) atau dikenali sebagai model teori klasik. Berdasarkan model yang digunakan oleh (Lily et. al., 2018), skor nilai *Cronbach's Alpha* yang boleh diterima adalah 0.61 hingga 0.99 sepertimana yang ditunjukkan dalam jadual 2.

Jadual 2. Interpretasi Skor *Cronbach's Alpha*

Skor Cronbach's Alpha	Interprestasi Kebolehpercayaan
0.9 – 1.0	Sangat baik dan efektif dengan tahap konsistensi yang tinggi
0.7 – 0.8	Baik dan boleh diterima
0.6 – 0.7	Boleh diterima
< 0.6	Item perlu dibaiki
< 0.5	Item perlu digugurkan

Dapatan kajian dari ujian realibiliti dengan menggunakan model *Cronbach's Alpha* mendapati nilai kebolehpercayaan yang diperoleh bagi item positif ialah 0.916 manakala bagi item negatif pula ialah 0.725 seperti yang ditunjukkan dalam Jadual 3.

Jadual 3. Nilai kebolehpercayaan (*Cronbach's Alpha*)

Item	Cronbach's Alpha	N of Items
Positif	.916	7
Negatif	.725	6

Terdapat 13 item pembolehubah untuk mengukur tahap kefahaman masyarakat Selangor terhadap konsep kesederhanaan dalam penggunaan. Melihat kepada pekali kebolehpercayaan Cronbach's Alpha seperti dalam jadual 3 mendapati bahawa ia merupakan satu nilai kebolehpercayaan yang baik dan boleh diterima yang mana ia akan menghasilkan keputusan yang konsisten setiap kali pengukuran dibuat (Lily et. al., 2018). Oleh itu, pembolehubah tahap kefahaman ini boleh dipercayai dan dijadikan hasil kajian.

4.3 Analisis Skala Likert

Setiap soalan yang diajukan akan diberi lima pilihan jawapan iaitu sama ada sangat tidak setuju, tidak setuju, tidak pasti, setuju dan sangat setuju. Dari segi pemberian markah, item yang berbentuk positif, gerak balas bagi kenyataan sangat setuju akan diberi lima markah dan kenyataan sangat tidak setuju diberi satu markah. Manakala bagi kenyataan yang negatif, gerak balas bagi jawapan sangat setuju diberi satu markah dan sangat tidak setuju diberi lima markah. Walau bagaimanapun terdapat satu item negatif (saya sanggup berhutang untuk mendapatkan sesuatu barangan keperluan) yang diberi lima markah sekiranya responden menjawab sangat setuju dan satu markah bagi jawapan sangat tidak setuju. Ini adalah kerana soalan tersebut perlu dijawab dengan kefahaman terhadap konsep kesederhanaan yang mengikut syariat Islam.

Jadual 4. Jumlah dapatan responden bagi item positif

	Kekerapan	Peratus an
Tidak Faham	47	23.2
Faham	113	55.7
Jumlah	160	78.8

Jadual 5. Jumlah dapatan responden bagi item negatif

	Kekerapan	Peratusan
Tidak Faham	15	7.4
Faham	144	70.9
Jumlah	159	78.3

Merujuk kepada jumlah dapatan responden bagi item positif dalam jadual 4 menunjukkan sebanyak 55.7% (113 orang) yang faham terhadap konsep kesederhanaan dalam penggunaan manakala sebanyak 23.2% (47 orang) yang tidak memahami konsep tersebut. Bagi item yang berbentuk negatif pula sebanyak 70.9% (144 orang) (rujuk jadual 5) yang memahami konsep kesederhaan dalam penggunaan manakala sebanyak 7.4% (15 orang) yang tidak memahami konsep ini.

Walaupun bagaimanapun, hasil dapatan tentang tahap kefahaman terhadap kedua-dua item ini digabungkan dengan memberi nilai 1 bagi individu yang memahami kedua-dua item positif dan negatif. Sekiranya salah satu item mendapat nilai 0 (tidak faham) maka, individu tersebut diberi markah 0 kerana hanya memahami 1 item sahaja sama ada positif atau negatif.

4.4 Ujian korelasi Pearson

Ujian korelasi Pearson digunakan bagi menjawab soalan-soalan kajian ini. Kekuatan perhubungan di antara pemboleh ubah-pemboleh ubah dalam kajian ini dianggar dengan menggunakan skala kekuatan yang digunakan dalam kajian Teh & Embi (2009) seperti dalam Jadual 6.

Jadual 6. Skala (Teh & Embi 2009) bagi kekuatan korelasi antara dua pemboleh ubah

Nilai Pekali	Tafsiran Deskriptif
0.7 – 1.00	Amat Tinggi
0.50 – 0.69	Tinggi
0.30 -0.49	Sederhana Tinggi
0.10 – 0.29	Rendah
0.01 – 0.09	Diabaikan

Jadual 7. Ujian Korelasi Pearson

		TOTALP	TOTALN
TOTALP	Pearson Correlation	1	-.056
	Sig. (2-tailed)		.480
	N	160	160
TOTALN	Pearson Correlation	-.056	1
	Sig. (2-tailed)	.480	
	N	160	160

Jadual 7 menunjukkan nilai signifikan jumlah skor bagi item positif dan negatif ialah $0.48 > 0.05$. Maka ini menunjukkan bahawa tiada hubungan korelasi antara pemboleh ubah item positif dengan pemboleh ubah item negatif.

4.5 Ujian logit binomial

Ujian logit binomial dijalankan dengan mengambil kira salah satu item (positif atau negatif) untuk dibuat analisis sebagai pemboleh ubah bersandar kerana hasil dapatan dari ujian korelasi pearson (rujuk jadual 7) menunjukkan tiada hubungan korelasi bagi kedua-dua item ini.

Setersanya, jadual 8 menunjukkan hasil dapatan secara keseluruhan tentang kefahaman terhadap konsep kesederhanaan dalam penggunaan. Terbukti dengan jelas bahawa terdapat frekuensi yang berbeza antara mereka yang memahami konsep kesederhanaan dalam penggunaan dan tidak memahami konsep kesederhanaan dalam penggunaan iaitu masing-masing sebanyak 63.1% dan 36.9%. Ini menunjukkan masyarakat di negeri Selangor yang memahami dan tidak memahami konsep kesederhanaan dalam penggunaan adalah tidak seimbang. Secara eksplisitnya jadual tersebut jelas menunjukkan ramai antara responden memahami konsep kesederhanaan dalam penggunaan berbanding mereka yang tidak memahami.

Jadual 8. Kefahaman terhadap konsep kesederhanaan dalam penggunaan

	Kekerapan	Peratusan
Faham	101	63.1
Tidak Faham	59	36.9
Jumlah	160	100

Jadual 9 menunjukkan penilaian terhadap kesesuaian model logit kepada data yang telah dikutip daripada responden. Ia membandingkan nilai yang dijangkakan daripada pemboleh ubah bersandar iaitu kefahaman terhadap konsep kesederhanaan dalam penggunaan dengan nilai sebenar data yang diperhatikan. Jadual klasifikasi tersebut menunjukkan model ini meramal 66.3% daripada pemerhatian sebenar. Model ini juga berupaya untuk meramal mereka yang memahami konsep kesederhanaan dalam penggunaan berbanding yang tidak memahami konsep tersebut. Perlu diingat bahawa jumlah yang memahami dan tidak memahami konsep kesederhanaan dalam penggunaan ini adalah tidak begitu seimbang. Dengan lain perkataan walaupun model ini berjaya meramal lebih daripada 50% pemerhatian dengan betul tidak seharusnya digunakan sebagai ukuran kesesuaian model. Oleh itu, dalam kajian ini kriteria kemungkinan bernisbah (lihat kajian Wahid et al. (2005)) akan digunakan seperti persamaan berikut :

$$C \text{ prop} = p^2 + (1-p)^2$$

Jadual 9. Jadual Klasifikasi Regresi Logistik

Pemerhatian	Diramalkan	
	Faham	Tidak Faham
Faham	87	14
Tidak Faham	40	19

Nota : Klasifikasi benar (%)

Faham = 86.1%; Tidak Faham = 32.2%; Keseluruhan = 66.3%

Apabila kriteria ini digunakan untuk sampel dengan nisbah 63.1% dan 36.9% (lihat jadual 8), tahap yang harus digunakan untuk menguji kesesuaian model ialah 50%. Jadual 9 jelas menunjukkan keupayaan model yang dianggar meramal dengan betul 66.3% daripada pemerhatian sebenar mengatasi tahap yang diperlukan untuk kesesuaian model.

Jadual 10. Nilai -2 Log Likelihood sebelum pemboleh ubah tidak bersandar dimasukkan

Iteration		-2 Log likelihood	Coefficients
			Constant
Step 0	1	193.843	.825
	2	193.752	.877
	3	193.752	.877

Jadual 10 menunjukkan nilai -2 Log Likelihood sebelum pemboleh ubah tidak bersandar dimasukkan dalam model. $N = 160$ mendapatkan Nilai -2 Log Likelihood iaitu 193.752. Darjah kebebasan (Degree of Freedom) = $N - 1 = 160 - 1 = 159$. Jadual chi-square (X^2) pada DF 159 dan kebarangkalian 0.05 = 189.424. Hasil dari regresi

logistik mendapati nilai -2 Log Likelihood iaitu 193.752 lebih besar dari nilai jadual chi-square (X2) iaitu 189.424. Oleh itu, keputusan menolak H_0 dan ini menunjukkan bahawa model sebelum memasukkan pemboleh ubah tidak bersandar adalah tidak fit dengan data.

Jadual 11. Nilai -2 Log Likelihood selepas pemboleh ubah tidak bersandar dimasukkan

Iteration		-2 Log likelihood	Coefficients	
			Constant	
Step 0	1	179.582	.180	
	2	178.353	.084	
	3	178.342	.068	
	4	178.342	.067	

Jadual 11 pula menunjukkan nilai -2 Log Likelihood selepas pemboleh ubah tidak bersandar dimasukkan dalam model: $N = 160$. Darjah kebebasan (DF) = $N - \text{jumlah pemboleh ubah tidak bersandar} - 1 = 160 - 7 - 1 = 152$. Jadual Chi-Square (X2) pada DF 159 dan kebarangkalian 0.05 = 181.770. Hasil dari regresi logistik mendapati nilai -2 Log Likelihood iaitu 178.342 lebih kecil dari nilai jadual chi square (X2) iaitu 181.770. Oleh itu, keputusan menerima H_0 dan ini menunjukkan bahawa model selepas memasukkan pemboleh ubah tidak bersandar adalah fit dengan data. Hal ini berbeza dengan jadual 10 di mana sebelum pemboleh ubah tidak bersandar dimasukkan ke dalam model, model tidak fit dengan data.

Jadual 12. Omnibus Tests of Model Coefficients

		Chi-square	df	Sig.
Step 1	Step	15.410	7	.031
	Block	15.410	7	.031
	Model	15.410	7	.031

Melihat kepada jadual 12, nilai X2 (15.410) lebih besar dari jadual X2 pada DF 7 (jumlah pemboleh ubah tidak bersandar 7) iaitu 14.067 atau dengan signifikan sebesar 0.031 (< 0.05) sehingga menolak H_0 , yang menunjukkan bahawa penambahan pemboleh ubah tidak bersandar dapat memberikan pengaruh nyata terhadap model atau dengan kata lain model dinyatakan fit.

4.6 Ujian Wald

Jadual 13. Hasil Keputusan Regresi Logistik Binomial

	Koefisien (B)	S.E.	Wald	df	Sig.	Exp Koefisien (B)
Jantina	0.176	0.394	0.200	1	0.655	1.193
Umur	-0.405	0.715	0.320	1	0.571	0.667
Status Kahwin	1.046	0.460	5.167	1	0.023	2.847
Kelayakan Akademik	0.669	0.617	1.175	1	0.278	1.951
Kawasan Tempat Tinggal	-0.550	0.454	1.471	1	0.225	0.577
Pendapatan Isi Rumah	0.059	0.417	0.020	1	0.887	1.061
Kerja Sampingan	1.184	0.408	8.421	1	0.004	3.267
Constant	0.067	0.879	0.006	1	0.939	1.070

Jika nilai P value ujian wald (sig.) bagi pemboleh ubah tidak bersandar lebih kecil dari 0.05, ini bermaksud pemboleh ubah tersebut mempunyai pengaruh separa yang signifikan terhadap pemboleh ubah bersandar di dalam model. Berdasarkan jadual 13 menunjukkan status kahwin mempunyai nilai signifikan Wald 0.023 lebih kecil dari 0.05 sehingga menolak H_0 dan ini bermaksud status kahwin memberikan pengaruh separa yang signifikan tahap kefahaman individu. Begitu juga dengan pemboleh ubah pekerjaan sampingan yang mempunyai nilai signifikan wald 0.004 lebih kecil dari 0.05 sehingga menolak H_0 dan ini bermakna pekerjaan sampingan memberikan pengaruh separa yang signifikan terhadap tahap kefahaman seseorang.

Jadual 13 juga menunjukkan hasil keputusan regresi logistik binomial yang juga menggunakan persamaan (7) iaitu menguji pengaruh tahap kefahaman terhadap konsep kesederhanaan dalam penggunaan. Hasil kajian ini menunjukkan terdapat 2 pemboleh ubah signifikan mempengaruhi tahap kefahaman masyarakat dalam memahami konsep kesederhanaan dalam penggunaan iaitu status kahwin dan kerja sampingan.

4.7 Nisbah Odds

Besarnya pengaruh ditunjukkan dengan nilai \exp koefisien (B) atau disebut juga Nisbah Odds (OR). Pemboleh ubah status kahwin dengan OR 2.487 maka individu yang sudah berkahwin (nilai 1 pada pemboleh ubah tidak bersandar), lebih memahami konsep kesederhanaan dalam penggunaan (nilai 1 pada pemboleh ubah bersandar) sebanyak 2.487 kali dibandingkan dengan individu yang belum berkahwin (nilai 0 pada pemboleh ubah tidak bersandar). Nilai $B = \text{Logaritma Natural dari } 2.487 = 1.046$. Oleh kerana nilai B bernilai positif, maka status kahwin mempunyai hubungan positif dengan tahap kefahaman seseorang individu.

Seterusnya, pemboleh ubah pekerjaan sampingan dengan OR 3.627 maka mereka yang melakukan kerja sampingan (nilai 1 pada pemboleh ubah tidak bersandar) lebih memahami konsep kesederhanaan (nilai 1 pada pemboleh ubah bersandar) sebanyak 3.627 kali dibandingkan dengan mereka yang tidak melakukan kerja sampingan (nilai 0 pada pemboleh ubah tidak bersandar). Nilai $B = \text{Logaritma Natural dari } 3.627 = 1.184$. Oleh kerana nilai B bernilai positif, maka melakukan kerja sampingan mempunyai hubungan positif dengan tahap kefahaman terhadap konsep kesederhanaan. Oleh itu, kajian ini membuktikan bahawa terdapat dua pemboleh ubah yang signifikan mempengaruhi tahap kefahaman terhadap konsep kesederhanaan seseorang individu iaitu pemboleh ubah status kahwin dan kerja sampingan. Dapat diperhatikan log nisbah odds bagi pemboleh ubah status kahwin adalah 2.847 dan signifikan pada aras keertian 5%. Nilai \exp koefisien (B) 2.847 yang bermaksud, sekiranya individu tersebut telah berkahwin, maka terdapat kebarangkalian individu tersebut memahami konsep kesederhanaan akan meningkat sebanyak 2.847. Di samping itu, log nisbah odds bagi pemboleh ubah kerja sampingan pula ialah 3.267 yang membawa erti, sekiranya seseorang individu melakukan kerja sampingan, maka terdapat kebarangkalian bahawa individu tersebut juga lebih memahami akan konsep kesederhanaan dalam penggunaan.

Secara keseluruhan, dua pemboleh ubah ini adalah bersifat positif dan signifikan terhadap tahap kefahaman seseorang terhadap konsep kesederhanaan dalam penggunaan. Hal ini berlaku mungkin disebabkan oleh golongan yang berkahwin akan lebih berhati-hati dalam membuat sebarang perbelanjaan kerana mereka mempunyai banyak komitmen lain yang perlu diambil kira. Justeru, ia mendorong kepada peningkatan tahap kefahaman bagi individu ini. Begitu juga dengan individu yang melakukan kerja sampingan kerana faktor yang menyebabkan mereka ini melakukan kerja sampingan adalah disebabkan masalah kewangan dan memerlukan wang tambahan. Oleh itu, secara tidak langsung, golongan ini akan berbelanja secara berhemah dan tidak mudah untuk melakukan pembaziran. Situasi tersebut akan memberi kesan kepada tahap kefahaman seseorang terhadap konsep kesederhanaan dalam penggunaan.

5.0 KESIMPULAN

Kefahaman terhadap konsep kesederhanaan dalam penggunaan adalah sangat penting. Ini memandangkan ia adalah satu perkara yang sangat dituntut dalam Islam iaitu bersederhana dalam apa jua aktiviti kehidupan seharian termasuklah dalam aktiviti ekonomi. Hasil kajian yang diperoleh bagi tahap kefahaman masyarakat negeri Selangor terhadap konsep kesederhanaan dalam penggunaan adalah tinggi. Walaubagaimanapun, dapatan ini tidak selari dengan isu yang sering berlaku pada masa kini seperti masalah individu muflis dan bankrap, isi rumah berhutang, masalah air di lembah Klang, sikap boros dalam berbelanja dan lain-lain lagi yang berunsur negatif. Status perkahwinan seseorang individu memainkan peranan penting dalam memberikan kefahaman terhadap nilai kesederhanaan. Perkara ini dibuktikan dengan hasil kajian yang menunjukkan terdapat hubungan yang signifikan antara status kahwin dengan tahap kefahaman. Individu yang telah berkahwin lebih memahami konsep kesederhanaan berbanding mereka yang belum berkahwin. Selain itu, kerja sampingan juga adalah faktor yang signifikan mempengaruhi tahap kefahaman seseorang. Hasil kajian menunjukkan mereka yang melakukan kerja sampingan lebih memahami konsep kesederhanaan dalam penggunaan berbanding mereka yang tidak melakukan kerja sampingan. Ini adalah kerana mereka yang melakukan kerja sampingan adalah untuk memenuhi keperluan harian.

Akhir sekali, bagi meningkatkan tahap kefahaman golongan bujang khususnya dan rakyat Malaysia umumnya terhadap konsep kesederhanaan dalam penggunaan, kajian ini mencadangkan pihak-pihak tertentu mengambil inisiatif untuk mengadakan program-program yang boleh memupuk sikap hidup secara sederhana agar pembentukan diri selari dengan kehendak syariat Islam. Pendidikan dan ilmu yang berkesan juga sangat penting bagi seseorang yang kurang memahami konsep kesederhanaan. Hasil dari ilmu yang diperoleh akan menjadikan seseorang individu berusaha untuk membentuk tingkah laku yang lebih baik dan akhirnya akan membentuk peribadi yang dituntut dalam Islam.

RUJUKAN

- Ab Rahim, N.M.Z., Suliaman, I. & Abd Razzak, M. 2012. Kesempitan Hidup Penghutang: Analisis Ayat 280 Surah Al-Baqarah. *Annual International Qur'anic Conference* 114–126.
- Abdul Basit Hodori, Sarmidi, T. & Saleh, N.H.M. 2014. Hutang dan Golongan Muda di Malaysia: Satu Kajian Awal. *Prosiding Persidangan Kebangsaan Ekonomi Malaysia Ke-99*: 833–844.
http://www.ukm.my/fep/perkem/pdf/perkem2014/PERKEM_2014_5C4.pdf.
- Ahmad Zaharuddin, S. bin A.S. 2004. Nilai Pengurusan Air Secara Islam dalam Komuniti dalam Pascamoden. *Seminar Antarabangsa Nilai dalam Komuniti Pasca Modernisme (SIVIC 2004)*
- Almenberg, J., Lusardi, A., Säve-Söderbergh, J. & Vestman, R. 2018. Attitudes Toward Debt and Debt Behavior. *National Bureau of Economic Research Working Paper Series* 1–31.
- Anas Zubedy. 2019. *10 Prinsip Kesederhanaan Rakyat Malaysia*.
- Baba, R., Muhammad Nor, N.Z. & Hamzah, M.A.F. 2018. Kerja Separuh Masa : Faktor, Status Pelajar Dan Kesan Ke Atas Pencapaian Akademik Pelajar Institusi Pengajian Tinggi. *Jurnal Inovasi Perniagaan* 3(1): 86–94. <file:///C:/Users/HP/Downloads/426-762-1-SM.pdf>.
- Gujarati & Dawn. 2009. *Basic Econometrics*. (5th Ed). New York: McGraw-Hill Irwin. Jabatan Insolvensi Malaysia. 2019. Statistik Kebankrapan
- Lea, S.E.G., Webley, P. & Walker, C.M. 1995. Psychological factors in consumer debt: Money management, economic socialization, and credit use. *Journal of Economic Psychology* 16(4): 681–701.
- Lily Hanefarezan Asbulah & Maimun Aqsha Lubis & Ashinida Aladdin & Mus'ab Sahrim. 2018. Kesahan dan Kebolehpercayaan Instrumen Strategi Pembelajaran Kolokasi Bahasa Arab: Analisis Menggunakan Model Rasch (Validity and Realibility of Arabic Collocation Learning Strategies Instrument: Analysis Using Rasch Model). *Jurnal Pendidikan Malaysia* 43(03): 131–140.
- Nur et. al. 2017. Gelagat hutang isi rumah mengikut kaum di Bandar Baru Bangi, Selangor (Malaysians in pursuit of the good life: A study of the nature of household debt by ethnic groups in Bandar Baru Bangi, Selangor). *Gelagat hutang isi rumah mengikut kaum di Bandar Baru Bangi, Selangor (Malaysians in pursuit of the good life: A study of the nature of household debt by ethnic groups in Bandar Baru Bangi, Selangor)* 11 (11)
- Nurshahirah Azman, R.H.Z. & S.M. 2013. Journal of Social. *Asian Journal of Social Psychology* 9 (1): 59–86.
- Panatik, S.A. 2004. Faktor–faktor Gaya Pembuatan Keputusan dalam Pembelian Barangan di Kalangan Pengguna. *Jurnal Teknologi* 41(1)
- Razak, N.A. & Mohd Dali, S.Z. 2012. Perbezaan Analisis Kepenggunaan Menurut Ekonomi Konvensional dan Ekonomi Islam. *Prosiding Perkem VII 2*: 1461–1470.
- Saifoul Zamzuri Noor Jabatan Ekonomi, M., Pusat Pengajian Ekonomi, P., dan Perbankan, K., Perniagaan, K., Ali Jabatan Ekonomi, J. & Hussin Baharuddin Jabatan Ekonomi, A. 2014. Persepsi Pengguna Terhadap Barangan Keperluan Berjenama 1 Malaysia di KRIM. *Kuala Terengganu* 9: 689–703.
http://www.ukm.my/fep/perkem/pdf/perkem2014/PERKEM_2014_4D1.pdf.
- Sanep Ahmad. 2017. *Analisis Ekonomi Islam*. Bangi: Penerbit Universiti Kebangsaan Malaysia.
- Siregar, K.I. 2013. Kesederhanaan Pribadi Nabi Muhammad dan Aplikasinya Dalam Fakta Sosial (Sebuah Kajian Nilai Al-Qur'an dan Hadis). *Jurnal Studi Al-Qur'an* 9(1): 53–71.
- Suhaila, N., Rabi'atul Adawiyah, S.N., Nuzul Akhtar, B. & Siti Syuhada, A.R. 2016. Faktor yang Mendorong Mahasiswa IPT Membuat Kerja Sambilan. *Education + Training* 2(2): 380–390.
<http://dx.doi.org/10.1016/j.nedt.2009.01.004> http://urj.ucf.edu/docs/URJmanuscript_Watanabe_080509.pdf <http://books.google.com/books?id=MAAd0s4o80SwC> <http://www.emeraldinsight.com/>
- Teh, K.S.M. & Embi, M.A. 2009. Korelasi Strategi dengan Motivasi dalam Pembelajaran Bahasa Arab. *Jurnal Pendidik dan Pendidikan* 24: 109–123.
- Toto Ngadiman, D.W., Rahim, H.A., Yacoob, S.E. & Wahid, H. 2018. Hubungan antara harga diri, niat menambah hutang dan gelagat perbelanjaan hutang dalam kalangan individu berpendapatan rendah. *Malaysian Journal of Society and Space* 14(4): 188–200.
- Toto Ngadiman, D.W., Rahim, H.A., Yacoob, S.E. & Wahid, H. 2019. Harga Diri, Niat Menambah Pinjaman Dan Gelagat Perbelanjaan Individu Muslim Berpendapatan Rendah Di Sektor Perladangan. *UMRAN - International Journal of Islamic and Civilizational Studies* 6(1): 49–61.
- Wahid, H., Mohd Noor, M. & Ahmad, S. 2005. Kesedaran membayar zakat: Apakah faktor penentunya? *International Journal of Management Studies (IJMS)* 12(2): 171–189.
- Zuroni et. al. 2016. Consumption and expenditure pattern of energy and water among urban consumers. *Jurnal Pengguna Malaysia* 26: 54–64.
- Zuroni Md Jusoh, Elistina Abu Bakar, A.J. & Sabri. 2010. Sikap Dan Amalan Perbelanjaan Pengguna Pada Musim Perayaan. *Jurnal Pengguna Malaysia* 15

UNDERSTANDING POTENTIALS OF HUMANITARIAN SUKUK AND ITS CONTRIBUTION TOWARD FINANCIAL REFUGEES CRISIS

Oumaima Touchibine^a, Nor Razinah Mohd Zain^b, Syed Marwan Syed Azman^c & Engku Rabiah Adawiah Engku Ali^d

*IUM Institute of Islamic Banking and Finance (IiBF)
International Islamic University Malaysia*

Abstract

Purpose – This paper aims to present an alternative to Financing Refugees. The purpose of the paper is the optimisation of the concept of Sukuk tool and its crucial role to mitigate several financial problems generated by Refugees crisis.

Design/methodology/approach – Using the existing literature on humanitarian initiative in Europe and incorporating these contributions into a Malaysian Humanitarian Aid. Several assumptions concerning the structure and operation of the sukuk are made, descriptively analysed.

Findings – The concept of sukuk could be used for the operation of an Islamic social finance instrument dedicated for humanitarian activism.

Research limitations/implications – Research that would inform the economic importance of sukuk would be served with an increased understanding of humanitarian initiatives and sukuk humanitarian.

Social implications – This paper could contribute to the effectiveness of sukuk humanitarian in their delivery of public good to the refugees. These implications are not restricted to a specific country. Charities and the refugees of any society may benefit from this study if the idea of total Islamic social finance is upheld.

Originality/value – This study is the first to address the structure and operation of a sukuk humanitarian to overcoming the financial refugee crisis.

Keywords: humanitarian initiative, sukuk, sukuk humanitarian, socioeconomic development.

1.0 INTRODUCTION

Limited financial resources is one of the main challenges encountered by the financial institutions charged to help the refugees in Malaysia and which is hindering them from contributing to the economic growth of the country. Furthermore, social bonds have not been taken into consideration in term of financial tool in addressing refugee crisis. Although the previous studies have highlighted on these challenges, however, less attention has been paid on how to offer a viable model that can overcome or address these issues.

2.0 FINDING

Despite the various initiatives undertaken, the refugees' crisis has generally remained persistent in many countries. According to the UN Refugee Agency their country, the number of forcibly displaced people in the world (refugees and asylum seekers) increased by 12% last year to reach 79.5 million. 26 million are refugees forced to flee their countries of origin due to conflict, persecution or serious human rights violations. Just under half of them are children under 18. 20.4 million of these refugees are of concern to UNHCR. 45.7 million are internally displaced, forced to flee within the borders of their own country. Finally, 4.3 million of these 79.5 million people are asylum seekers. Filippo Grandi, United Nations High Commissioner for Refugees, (2020), warned: "We are witnessing a change in reality where forced displacement is both much more frequent, and where the phenomenon is no longer short-term and transitory. People cannot be expected to live in turmoil for years to come, without the opportunity to return home or build a future where they are. We must adopt a fundamentally innovative and more welcoming attitude towards those who flee, combined with a determined effort to end the conflicts which have endured for years and are at the very root of such intense suffering".

Serving as a geographic springboard to the European Union for the millions of people fleeing the conflict in Syria, Turkey is by far the country that hosts the largest number, 3.6 million. Colombia, a neighbor of Venezuela, a country going through one of the worst economic and social crises in its history, comes in second with 1.8 million

refugees. Germany is the only European country to be among the top ten host countries. As for France, it hosted just over 400,000 refugees at the end of 2019 and is ranked fourteenth in the world.

Respecting Malaysia, according to the UN Refugee Agency, there are some 177,940 refugees and asylum-seekers registered with UNHCR in Malaysia, as of end of June 2020. There are some 24,750 refugees and asylum-seekers from other countries, including some 6,670 Pakistanis, 3,650 Yemenis, 3,280 Somalis, 3,260 Syrians, 2,660 Afghans, and 1,760 Sri Lankans, 1,230 Iraqis, 770 Palestinians, and others from other countries. Some 68% of refugees and asylum-seekers are men, while 32% are women. There are some 46,370 children below the age of 18. Despite some progress in increasing the number of refugees, in the last years Europe are rejecting to accept us while refusing their human rights. That why the majority of refugees are facing many problems such as the loss of lives with majority children, social problems, cross-border conflict, and numerous types of abuse.

Recently, Europe forcing the refugees being pushed back across borders, especially those moving onwards irregularly, because several factors that affected negatively the economics' situation. It was obvious that Europe was affected by the Global Financial crisis. This leads to a devastating situation which include the lack of fund to finance the needs of the refugees, thus the European Union introduced new asylum procedures to mitigate the risks generated by the refugees' crisis and new measures in sight to limit aid to migrants.

The government is considering several new measures to reduce the demand for asylum, the saturation of accommodation or the cost of aid granted to migrants and refugees (Nathalie Birchem, 2019). The new asylum procedure intended to reduce the among of asylumseeker. The Minister of the Interior is seeking to expel more of them first. According to Mediapart, a plane to return 90 Georgians, including 42 children, took off from Toulouse to Tbilisi on June 28. The executive, who met a fortnight ago on this subject, is also seeking to discourage asylumseekers by cutting back on the aid granted to these two nationalities. "They are considering reducing the ADA (Allocation pour demandeur d'asile) by 25% after the rejection of the asylum application, not at the end of the appeal, but at the rejection by Ofpra for " safe countries of origin ", including Georgia and Albania, but also Senegal (explains LREM deputy Aurélien Taché). According to another source, the decree is already in the Council of State.

So, with the actual situation, Europe can't furnish properly welfare to the refugees because they can't provide adequate reception and assistance for those arriving from their countries in order to seek a good condition while securing their well-being. This lack of funds leads Europe to reduce the needs of the refugees. This is an important gap that needed to be addressed.

In the last few decades, Malaysia becomes the most country that accept the refugees to access its territory. To avoid that Malaysia can be contracted the same problem of lack in funding, it is essential for it to become the first country that introduces sukuk's structure for humanitarian activism, securing the well-being of refugees, and simultaneously, achieving the required SDGs. Those arriving in Malaysia need suitable reception and help, particularly those with specific needs, including unaccompanied and separated children and survivors of sexual and gender based violence, and access to fair and efficient asylum procedures. More solidarity is needed within the Malaysia to ensure protection, including through efficient and speedy family reunion and relocation. Overall, there is a need for a comprehensive plan of action that will support long-term solutions to the complex issue of refugees' crisis and help address the issue of funding.

It is important that Malaysia introduced Humanitarian Sukuk as an alternative financial tool in addressing refugee crisis. Therefore, the objective of this research is to evaluate financial assistance implemented by the European Union government or the UN Refugee Agency with focus on the types of the issue in funding, identify their limitations and fill up the gap in Malaysian refugees crisis from an Islamic microeconomics perspective by introducing the best model structure of sukuk for overcoming the refugee crisis by collecting the necessary funds.

3.0 LIMITATION OF STUDY

Humanitarian sukuk and social institutions are two main concepts to be discussed in this research figuring out their possible potential benefits for the sustainable development goals in Malaysia. This study will not cover certain important areas of legal framework needed to be designed for helping government to fill up this gap. The major focus of this study is on the humanitarian sukuk as a solution from Islamic microeconomic perspective to aid government to recovery the deficit of funding to finance the needs of the refugees in Malaysia, further research is required to cover other tools financing the refugees crisis.

4.0 LITERATURE REVIEWS

This literature review is built based on the inverted pyramid structure, where the gaps of knowledge are identified at the end of the discussion (Kross and Giust, 2019). It is believed that by employing such structure in the literature review, the research objectives can be well supported and the gaps of knowledge can be effectively addressed. In doing so, the literature review is provided based on relevant and related themes. They are: (i) Protection of Refugees as a Part of Achieving SDGs; (ii) the Practice of Sukuk as Islamic Social Finance Instrument; (iii) Malaysia and Sukuk Issuance; (iv) Humanitarian Sukuk, and (v) the identified gaps of knowledge.

4.1 Protection of Refugees as a Part of Achieving SDGs

In 1951, the world was introduced to the Refugee Convention of 1951 with ratifications of 145 United Nations' member states. Under this convention, a person that is known as a refugee has a right not to return to a country where he faces serious threatening causes that may hostile to his life or freedom. It is consistent with Article 14 of the Universal Declaration of Human Rights 1948 that recognises the right of persons to seek asylum from persecution in other countries (UNDHR, 1948). Today, this right is now accepted as a part of international customary law (UNCHR, 2018). Based on Article 1 of the Refugee Convention 1951, a refugee is identified as a person "... who has been forced to flee his or her country because of persecution, war, or violence... has a well-founded fear of such persecution for reasons of race, religion, nationality, political opinion or membership in a particular social group" (Refugee Convention, 1951; CARE, 2018). Due to such serious persecution, war, or violence, the refugee fears of his life and freedom to return to his home. Based on the said convention and its Protocol of 1967, a refugee must be given a protection in order to secure his life and freedom by the asylum country as appropriately as possible.

Since the establishment of United Nations, they have worked to protect and secure the lives and freedom of refugees around the globe. Under the auspicious of United Nations, the United Nations High Commissioner of Refugees (UNHCR) was established and they estimated that there was approximately 1 million refugees in 1951. However, this number is drastically increased since then. Now, it is estimated that there are "... 17.5 million refugees, an additional 2.5 million refugees cared for by the United Nations Relief and Works Agency for Palestine refugees in the Near East (UNRWA) and more than 25 million internally displaced persons" (OHCHR, 2018). While the world is committed to achieve the sustainable development goals or SDGs, it is important to consider the protection and its sustainability for refugees around the world or at least those who are seeking asylum within the countries. The ultimate success of SDGs must accordingly consider the existence of refugees and their protections. Moreover, the main objective of SDGs is to resolve the issues of environmental, political, and economic globally (UNDP, 2018).

According to UNHCR (2018), with the world that "increasingly affected by climate change, poverty and conflict, the SDGs cannot be achieved without taking into account the rights and needs of refugees, internally displaced and stateless people". Thus, it is necessary to consider the refugees in achieving a complete success of SDGs. The most profound principles relating to refugees that can be found from the SDGs 2030 Agenda are:

- Paragraph 4: no one will be left behind... and that Goals and targets will be met for all nations and peoples and all segments of society;
- Paragraph 23: "Those whose needs are reflected in the Agenda include all ... refugees and internally displaced persons and migrants. We resolve to take further effective measures and actions, in conformity with international law, to remove obstacles and constraints, strengthen support and meet the special needs of people living in areas affected by complex humanitarian emergencies and in areas affected by terrorism" (SDGs, 2012).

Thus, it is necessary for the member states to have a serious consideration in the success of achieving SDGs by including the protection of refugees in their country's sustainable governance and development policy. Most importantly, it is necessary to generate enough financial assistances for the refugees; so, at the end, they can sustainably able to provide for themselves and their families in the long run.

4.2 Practice of Sukuk as Islamic Social Finance Instrument

According to Mohd. Zain and Engku Ali (2017), Sukuk is one of the Islamic social finance instruments that can be used for a purpose of investment or purely philanthropic in nature. Once, the Sukuk stands with philanthropic intention, other instruments of Islamic social finances such as Zakat and Sadaqat may be combined to structure the entire operation of Sukuk. Sukuk (plural) or Sak (singular) literally means "any written document" (ISRA & SCM, 2017). Sukuk are the Islamic securities instrument that depends on the underlying principles of the Islamic transaction law. It is often be referred to as the Islamic bonds. According to A. Saeed (2014), the term "Islamic bond" does not portray the exact substance of Sukuk. Sukuk is defined by the Islamic Financial Services Board (IFSB) as the "certificates with each sakk representing a proportional undivided ownership right in tangible assets,

or a pool of predominantly tangible assets, or a business venture (such as mudarabah). These assets may be in a specific project or investment activity in accordance with Shariah rules and principles” (IFSB-7, 2009).

According to IFSB, Sukuk are basically different from the conventional bonds based on: “(a) The funds raised through the issuance of Sukuk should be applied to investment in specified assets rather than for general unspecified purposes. This implies that identifiable assets should provide the basis for Islamic bond; (b) Since the Sukuk are based on the real underlying assets, income from the Sukuk must be related to the purpose for which the funding is used; (c) The Sukuk certificate represents a proportionate ownership right over the assets in which the funds are being invested. The ownership rights are transferred, for a fixed period ending with the maturity date of the Sukuk, from the original owner (the originator) to the Sukuk holders” (IFSB-7, 2009).

The first development of modern Sukuk in the 20th century can be traced back to 1970’s. In Jordan, the Ministry of Awqaf (public endowments), Islamic Affairs and Holy Places issued muqaradah sukuk (that have similar features with mudarabah principles) in 1977 (ISRA & SCM, 2017). Through such issuance of sukuk, the investors provided the funding to the existing government. In return, the benefits from profit sharing in economically viable to the development projects. Based on the mudarabah principles, the investors agreed to provide the capital, while the government’s agency performed the works.

At the end, the parties shared in the venture based on profit sharing as per agreed ratio. The government was also participated as a guarantor for the invested capital by the investors. Beside of having the issuance of Muqaradah Sukuk in Jordan, the Participation Term Certificates (PTC) was issued in Pakistan as early as 1980. Malaysian government also issued the certificates that were known as the Government Investment Issues (GII), while in Turkey, they issued Revenue Sharing Certificates (RSC) in 1984 (ISRA & SCM, 2017). After the early experiments of issuances of Sukuk, a successful issuance of Sukuk in a large scale was done by Shell MDS Malaysia Sdn. Bhd. with a value of RM125 million (USD30 million). They depended on the Bay’ Bithaman al-Ajil structure. The said issuance of Sukuk managed to attract the attentions of both local and international investors on the potentials of sukuk in generating funds and creating growth in the investment and securities market. Subsequently, several more issuances of Sukuk were made in Malaysia.

4.3 Malaysia and Sukuk Issuance:

According to a report by Thomas Reuters (2017), Malaysia is ranked at the first place in the issuances of Sukuk with USD23.14 billion worth value. This is followed closely by United Arab Emirates (with USD3.95 billion worth value) and Saudi Arabia (with USD3.20 billion worth value). Moreover, there are also introduction of innovations of Sukuk that suits the investments to social needs of the society, while assisting the growth of the economy in the countries. As identified by Mohd. Zain et. al (2017), the innovations of Sukuk can be traced from (i) Social Impact Sukuk (SIS), (ii) Socially Responsible Investment Sukuk (SRI), (iii) Green Sukuk (GS),

4.4 Waqf Sukuk (WGS), and (v) Wakalah Sukuk

Beside of having different underlying Islamic based contracts, structures, and operation, the innovations of Sukuk are also considered different from their objectives and types of investments. Thus, Sukuk may be utilised for philanthropic purposes while meeting the SDGs.

4.5 Humanitarian Sukuk:

The term of “Humanitarian Sukuk” is not invented by the researchers. However, it is already used from the earliest efforts to introduced it to the world. The popular mentioned of humanitarian Sukuk can be found from the efforts of United Kingdom based Islamic Relief Worldwide in 2016 to utilise Sukuk in generating funds to overcome humanitarian crisis, including the Syrian refugee crisis in Europe (Islamic Finance, 2016). The earliest issuances of humanitarian Sukuk can be traced in 2015 (worth of USD500 million) and 2016 (worth of USD200 million) by the International Finance Facility for Immunization for the Global Alliance. While in the form of conventional bond which worth USD27.65 million, the Red Cross utilised the proceeds to provide three physical rehabilitation centres in Africa (Defex, 2017).

Before a further discussion is put forward here, it is essential to understand what is meant by the term “humanitarian”. Literally, humanitarian is defined as “a person who is involved in or connected with improving people’s lives and reducing suffering” (Cambridge Dictionary, 2018) or “concerned with or seeking to promote human welfare” (Oxford Dictionary, 2018). For the purpose of this research, the humanitarian sukuk is understood as the certificates or sakk (that representing a proportional undivided ownership right in tangible assets, or a pool of predominantly tangible assets, or a business venture) are used as innovative financing mechanism to promote

PREMIS MAKANAN INDUSTRI KECIL DAN SEDERHANA DALAM SEKTOR HALAL: ISU DAN PERMASALAHAN

Syarifah Md Yusof^a, Azizah Othman^b, Raziah Md Tahir^c, Nor Aina Mhd Khotib^d Emy
Ezura A.Jalil^e & Nor Aina Mardhiah Nazim^f

^{abc}Institut Penyelidikan dan Inovasi Zakat dan Pusat Pengajian Perniagaan Islam, Universiti Utara Malaysia

^dPusat Pengajian Perniagaan Islam, Universiti Utara Malaysia

^eTechnology and Supply Chain Excellence Institute dan Pusat Pengajian Pengurusan Teknologi dan Logistik, Univeristi Utara Malaysia

Abstrak

Malaysia ingin menjadi hab halal diperingkat global dengan menawarkan pelbagai produk makanan halal. Walaupun begitu, isu ketidakpatuhan premis makanan di Malaysia amat serius. Terdapat begitu banyak premis makanan di seluruh negara, namun, jumlah premis makanan yang mematuhi pensijilan halal Malaysia amat sedikit. Kajian yang merungkai permasalahan ini amat terhad. Justeru, kajian ini bertujuan untuk meneroka isu utama kepatuhan halal dalam operasi premis makanan berskala kecil dan sederhana dan mencadangkan model pematuhan berterusan pensijilan halal Malaysia bagi premis makanan berskala kecil dan sederhana. Untuk mencapai objektif yang ditetapkan, kajian ini menggunakan pendekatan kualitatif menerusi teknik temu bual mendalam bagi mengutip data. Temu bual separa berstruktur dilakukan dengan pengusaha premis makanan yang dipilih di Wilayah Utara Semenanjung Malaysia meliputi Pulau Pinang, Kedah dan Perlis. Output signifikan kajian ini ialah model yang dapat dimanfaatkan oleh pembuat polisi seperti JAKIM dan pihak berkuasa tempatan dalam meningkatkan bilangan premis makanan yang mematuhi pensijilan halal.

Kata Kunci: Pengurusan Halal, Perusahaan kecil dan Sederhana, Sektor Makanan, Penguatkuasa Tempatan, JAKIM

1.0 PENGENALAN

Pasaran halal global kini bernilai US\$2.3 trilion (US\$1=RM4.42) setahun dengan sektor makanan halal, sebagai komponen teras bernilai US\$660 bilion. Malaysia kini sedang mengorak langkah untuk menjadi hab halal global. Pensijilan halal Malaysia menjadi “hype” pemasaran kepada semua produk halal Malaysia. Pensijilan halal Malaysia terbahagi kepada tujuh skim iaitu produk makanan / minuman / makanan tambahan, premis makanan/hotel, barang gunaan, kosmetik dan dandanan diri, rumah sembelih, farmasutikal dan logistik. Merujuk kepada direktori halal JAKIM, terdapat sebanyak 6114 premis makanan yang memperolehi pensijilan halal Malaysia, namun sebahagian besarnya adalah premis restoran francais seperti KFC, Mc Donald, Pizza serta dapur/restoran hotel dan resort. Bilangan premis berskala kecil dan sederhana seperti kafe, medan selera, kantin, kiosk dan restoran persendirian yang bukan berbentuk rangkaian atau francais agak kecil (Direktori Halal JAKIM, 30 Jun 2020) <http://www.halal.gov.my/ehalal/directory>

Pematuhan makanan halal merupakan isu asas yang terus membelenggu umat Islam. Tahap kepatuhan mereka bergantung kepada keberkesanan usaha penguatkuasaan. Secara amnya diandaikan bahawa tahap penguatkuasaan yang tinggi akan mendorong kepada tahap pematuhan yang tinggi (Hashim, Saad, Khalid, & Laluddin, 2018). Walau bagaimanapun, penguatkuasaan melibatkan kos dari segi kewangan, modal insan dan masa. Kajian Hashim et al., (2018) mengkaji sistem pengawal seliaan dalam industri ternakan yang diamalkan di Malaysia dan meneroka masalah biasa yang dihadapi oleh pihak berkuasa dalam menguatkuasakan pematuhan halal dalam kalangan rumah sembelihan dan pemprosesan ayam. Kebanyakan masalah yang dihadapi dalam kajian ini adalah tahap pematuhan dan keberkesanan usaha penguatkuasaan.

Tambahan pula, kajian Sayogo (2018) mencadangkan bahawa pengguna Islam melihat keupayaan untuk mengesan pematuhan produk terhadap prinsip-prinsip halal sebagai berguna dan penting. Persepsi pengguna Islam mengenai kebolehpengesanan dalam talian yang berguna adalah dipengaruhi oleh tiga faktor utama: kecenderungan pengguna untuk mempercayai, gaya hidup yang sihat dan reputasi syarikat, serta badan pensijilan (Sayogo, 2018). Kepatuhan halal bagi premis makanan yang begitu banyak di negara ini menjadi persoalan memandangkan hanya sebilangan kecil sahaja yang mendapatkan pensijilan halal Malaysia (Nora, Mohd Nasaruddin & Nur Fatin, 2016). Terdapat pengusaha premis makanan berskala kecil dan sederhana yang

mengambil jalan mudah dengan mempamerkan “pork free” atau menggantung ayat Quran sebenarnya tidak menjanjikan sesebuah restoran itu menghidangkan makanan halal seratus peratus (Nora, MohdNasaruddin & Nur Fatin, 2016).

Hal demikian kerana sumber bahan mentah dan ramuan seperti ayam dan daging lembu merupakan antara perkara yang sangat kritikal dalam menentukan status halal. Pada masa yang sama, proses penyediaan makanan, penyimpanan bahan mentah, pekerja, peralatan memasak, keadaan dapur, serta aspek kebersihan turut mempengaruhi status halal premis makanan. Ketidapatuhan premis makanan terhadap piawaian halal yang ditetapkan oleh JAKIM didorong oleh kekurangan pengetahuan, isu pembekal dan isu tadbir urus halal (Ilyia, Rosli, Suhaimi dan Dzulkifly, (2011).

Kelemahan dalam pelaksanaan kawalan pematuhan produk halal telah membuka ruang kepada ketidapatuhan piawaian halal. Kelemahan tersebut menyebabkan berlakunya pelbagai kegiatan penipuan termasuk pemalsuan sijil dan logo halal, percampuran bahan ramuan tidak halal semasa pemprosesan makanan, penipuan dalam pengistiharan bahan ramuan, penambahan produk baru tanpa membuat pengistiharan. Hal ini terbukti apabila ketidapatuhan piawaian halal didedahkan oleh akhbar-akhbar harian negara (Berita Harian, 2017; Utusan Online, 2010). Selain itu, Akhbar Malaysiakini turut melaporkan tentang isu penyalahgunaan logo halal. Sebuah Restoran masakan India yang terkenal di Georgetown, Pulau Pinang dikenakan kompaun oleh Majlis Perbandaran selepas didapati mempamerkan logo halal tanpa kebenaran JAKIM (Mstar, 16 Januari 2019). Isu-isu yang dibincangkan di atas tidak merungkai isu kepatuhan halal yang dihadapi oleh premis makanan berskala kecil dan sederhana. Justeru, kajian ini bertujuan untuk meneroka dan memahami isu kepatuhan halal dalam operasi premis makanan yang meliputi rangkaian bekalan sehingga penyajian makanan di premis (from farm to fork). Pada masa yang sama kajian ini juga mengenal pasti faktor yang mempengaruhi pematuhan halal dalam operasi premis makanan serta kaedah pemantauan ke atas premis makanan berskala kecil dan sederhana.

2.0 LITERATUR

Halal

Konsep halal dalam Islam menetapkan supaya setiap umatnya memakan makanan halal sahaja seperti firman Allah SWT dalam Surah al-Baqarah ayat 168 yang bermaksud:

“Wahai sekalian manusia, makanlah dari apa yang ada di bumi yang halal lagi baik, dan janganlah kamu ikut jejak langkah syaitan kerana sesungguhnya syaitan itu ialah musuh yang terang nyata bagi kamu.”(al-Baqarah 2:168)

Dalam Surah al-Ma’idah ayat 88 pula Allah SWT berfirman yang maksudnya:

“Wahai para Rasul, makanlah dari (makanan) yang baik-baik dan kerjakanlah kebajikan. Sesungguhnya Allah maha mengetahui apa yang kamu kerjakan.”(al-Ma’idah 5:88)

Ayat-ayat al-Quran tersebut menunjukkan betapa pentingnya kedudukan harta halal dalam Islam dan ketentuan halal dan haram adalah hak Allah SWT (al-Qaradawi, 2013). Menjadi kewajipan setiap Muslim untuk mentaati perintah Allah SWT.

Halal adalah perkataan Arab yang bermaksud dibenarkan atau dibolehkan oleh hukum syarak (JAKIM, 2015). Halal merujuk kepada apa sahaja yang bebas daripada sebarang unsur yang dilarang penggunaannya dalam Islam (Zalina, 2008). Konsep halal tayyiban dalam Islam meliputi tiga aspek. Aspek pertama ialah pematuhan kepada hukum syarak, iaitu tidak mengandungi najis atau bahan-bahan yang dilarang penggunaannya menurut hukum syarak. Kedua, aspek kebersihan iaitu bersih dan suci daripada kotoran dan najis. Aspek terakhir ialah keselamatan iaitu, selamat dan tidak memudaratkan, tidak mengandungi racun atau bahan kimia yang boleh menimbulkan kesan buruk atau bahaya kepada kesihatan (JAKIM, 2015; Maa’mor, 2003).

Hukum yang bertentangan dengan halal adalah haram. Dalam soal makanan, halal dan haram adalah istilah yang menerangkan status hukum suatu makanan iaitu sah atau tidak sah menurut hukum Allah SWT. Islam telah meletakkan garis panduan dan peraturan yang jelas mengenai perkara ini yang dijelaskan dalam al-Quran dan hadis. Ini bermakna isu halal dan haram berkait rapat dengan soal keimanan umat Islam iaitu berkaitan dengan sejauh mana pematuhan seseorang individu kepada peraturan dan perintah Allah (Noor Aini & Mohd Ali, 2013).

Perusahaan Kecil dan Sederhana (premis makanan)

Definisi PKS adalah seperti berikut: Pembuatan: Jualan tahunan tidak melebihi RM50 juta atau bilangan pekerja sepenuh masa tidak melebihi 200 orang. Perkhidmatan dan lain sektor: Jualan tahunan tidak melebihi RM20 juta atau bilangan pekerja sepenuh masa tidak melebihi 75 orang. Sesebuah perniagaan boleh diklasifikasikan sebagai

PKS jika memenuhi salah satu daripada dua kriteria iaitu jualan tahunan atau bilangan pekerja sepenuh masa, mana-mana yang lebih rendah (SMEinfo, <http://www.smeinfo.gov.my>).

Butiran terperinci bagi definisi baharu PKS adalah seperti berikut:

Jadual 1: Definisi berdasarkan saiz operasi

Kategori	Perusahaan Kecil	Perusahaan Sederhana
Pembuatan	Jualan tahunan daripada RM 3000,000 kepada kurang daripada RM15 juta atau bilangan pekerja sepenuh masa daripada 5 orang kepada kurang daripada 75 orang	Jualan tahunan daripada RM 15 juta kepada tidak melebihi RM 50 juta atau bilangan pekerja sepenuh masa daripada 75 orang kepada tidak melebihi 200 orang.
Perkhidmatan dan Sektor Lain	Jualan tahunan daripada RM 300,000 kepada kurang daripada RM 3 juta atau bilangan pekerja sepenuh masa daripada 5 orang kepada kurang 30 orang.	Jualan tahunan daripada RM 3 juta kepada tidak melebihi RM 20 juta atau bilangan pekerja sepenuh masa daripada 30 orang kepada tidak melebihi 75 orang.

Bagi premis makanan, klasifikasi kecil dan sederhana berdasarkan nilai perolehan tahunan yang berbeza dengan sector pembuatan dan perkhidmatan. Nilai perolehan tahunan kurang daripada RM500,000 dikategorikan sebagai industri kecil. Industri sederhana pula mempunyai perolehan tahunan antara RM500,000 hingga RM5 juta, manakala nilai perolehan tahunannya melebihi RM5 juta termasuk dalam kategori industri besar (JAKIM, 2019).

Jadual 2: Jenis industri bagi premis makanan

Jenis industri	Ciri-ciri
Kecil	Nilai perolehan tahunan kurang daripada RM500,000
Sederhana	Nilai perolehan tahunan daripada RM500,000 hingga RM5 juta
Besar	Nilai perolehan tahunan melebihi RM5 juta

Premis makanan bermaksud sebarang bangunan atau apa-apa struktur, kekal atau sebaliknya bagi penyediaan, penyajian dan penjualan sebarang makanan seperti restoran, medan selera, kafeteria, kedai bakeri, kedai kek dan pastri, restoran makanan segera, restoran francais, kantin, kiosk, katering, dapur hotel dan lain-lain (JAKIM, 2015). Menurut Pensijilan Halal Malaysia, terdapat sembilan sub kategori di bawah skim premis makanan. Sub kategori tersebut ialah restoran/ kantin/ kafe, restoran berangkai, restoran francais, hotel (dapur/ restoran), medan selera/ kafeteria yang mempunyai pengurusan berpusat, kedai bakeri/kek/ pastri, kiosk, katering/ khidmat penyajian makanan/dapur pusat konvensyen dan premis bergerak (yang mempunyai pengurusan/ dapur berpusat sahaja).

Restoran berangkai, restoran francais dan hotel (dapur/ restoran) lazimnya dimiliki oleh syarikat multinasional atau syarikat berskala besar. Sebaliknya sub kategori yang lain seperti kantin medan selera dan kafeteria adalah perniagaan berskala sederhana dan kecil.

Pematuhan Halal

Penggunaan istilah seperti 'pork free' dan 'no alcohol' di premis makanan masih belum menjamin hidangan sajiannya benar-benar halal. Menurut Islam, hidangan halal bukan hanya kerana ketiadaan bahan bersumberkan babi, malah ia perlulah mematuhi konsep halal yang ditetapkan dalam Islam. Konsep halal meliputi keseluruhan proses daripada bahan mentah sehinggalah produk akhir sampai kepada pengguna (*from farm to fork*). Dengan kata lain, pengurusan halal adalah amat kritikal dan signifikan diambil berat oleh premis makanan bagi menjamin makanan yang dihasilkan dan dihidangkan oleh premis makanan mereka menepati konsep halal sebagaimana yang menjadi piawai halal JAKIM. Pihak JAKIM menetapkan bahawa premis makanan selain daripada restoran berangkai, restoran francais dan hotel (dapur/ restoran) hanya memerlukan kepada seorang penyelia Muslim sebagai orang yang bertanggungjawab terhadap pematuhan halal, di samping seorang pekerja Muslim bertugas di dapur.

Syed Marzuki, Hall dan Ballantine (2012, 2014) mendapati pengurus restoran mempunyai ekspektasi yang tinggi terhadap pensijilan halal memandangkan ia memberi manfaat kepada semua pihak. Razali et al (2017) pula mendapati faktor permintaan pelanggan, pemasaran, komitmen pihak pengurus atasan, keselamatan produk dan kualiti produk menjadi faktor mendorong operator restoran untuk mendapatkan pensijilan halal Malaysia. Kajian yang lain mendapati golongan muda mempunyai sikap yang positif terhadap premis makanan

halal (Abdul Khalek, 2012). Oleh hal yang demikian, amat perlu kepada kajian pematuhan halal agar lebih banyak premis makanan mematuhi pensijilan halal Malaysia.

Pematuhan pensijilan halal Malaysia Menurut Kamus Dewan Online, perkataan pematuhan bermaksud perbuatan mengikut perintah. Dalam bidang zakat, kepatuhan zakat memberi maksud kepatuhan sebagai patuh atau gagal kepada hukum Allah S.W.T dan peraturan yang dikeluarkan oleh institusi zakat (Ram Al Jaffri, (2010). Siti Khalilah, Azizi dan Ram Al Jaffri (2017) pula merujuk gelagat kepatuhan piawaian halal sebagai mematuhi peraturan-peraturan yang telah ditetapkan oleh JAKIM bagi menepati prinsip-prinsip Islam yang sebenar iaitu halalan tayyiban dalam penghasilan produk.

JAKIM memainkan peranan utama dalam mengeluarkan Pensijilan Halal kepada pengeluar dan pengusaha. Pensijilan halal Malaysia bagi skim premis makanan hendaklah mematuhi: i. MS1500: 2009 Makanan Halal – Pengeluaran, Penyediaan, Pengendalian dan Penyimpanan - Garis Panduan Umum (Semakan Kedua). ii. Akta Makanan 1983 (Akta 281), Peraturan-Peraturan Makanan 1985 dan Peraturan-Peraturan Kebersihan Makanan 2009. iii. Keputusan Jawatankuasa Fatwa Majlis Kebangsaan Bagi Hal Ehwal Ugama Islam atau Fatwa yang diwartakan oleh negeri (JAKIM, 2015). Pensijilan halal Malaysia yang dijalankan ketika ini adalah bersifat sukarela dan terbuka kepada semua pemohon tanpa mengira status agama mahupun bangsa. Hanya pemohon yang memenuhi syarat dan mematuhi segala prosedur yang ditetapkan sahaja layak diberikan Sijil Pengesahan Halal Malaysia (SPHM).

3.0 METODOLOGI

Kajian ini menggunakan pendekatan kualitatif dalam mengutip dan menganalisis data. Pendekatan kualitatif akan digunakan bagi menjawab semua persoalan kajian. Skop kajian ini memfokuskan kepada premis makanan yang terdapat di Wilayah Utara iaitu Pulau Pinang, Kedah dan Perlis. Sumber data Oleh kerana kajian ini lebih bersifat kualitatif, kaedah pengutipan data secara mendalam (in-depth data collection) lebih sesuai dilakukan dalam kajian ini.

Kaedah kajian lapangan menerusi temu bual digunakan untuk pengumpulan data primer. Temu bual melibatkan dua pihak iaitu operator premis makanan dan pakar dalam bidang halal.

- i. Temu bual informan (operator premis makanan) untuk memenuhi objektif satu iaitu meneroka isu utama kepatuhan halal dalam operasi premis makanan berskala kecil dan sederhana.
- ii. Temu bual kumpulan pakar

Pemilihan sampel Kajian ini melibatkan premis makanan di tiga negeri di Wilayah Utara iaitu Pulau Pinang, Kedah dan Perlis. Sampel akan dipilih menggunakan kaedah persampelan bertujuan. Pengusaha premis makan yang terpilih akan dihubungi untuk mendapatkan persetujuan mereka untuk ditemu bual.

Kaedah Penganalisisan data adalah melibatkan data yang bersifat kualitatif. Data kualitatif adalah naratif. Data naratif diperolehi daripada temu bual bersama operator premis makanan dan kumpulan pakar. Transkrip temubual akan dikodkan untuk mengenal pasti tema data. Data analisis ini melibatkan tiga peringkat iaitu (Miles, Huberman and Saldana, 2014):

- i. Kesimpulan Data (Data condensation)
- ii. Pembentangan data (Data Display)
- iii. Melakar kesimpulan dan kesahan (Drawing conclusion and verification)

4.0 DAPATAN DAN PERBINCANGAN KAJIAN

Bagi menjawab persoalan kajian yang pertama iaitu apakah isu utama kepatuhan halal dalam operasi premis makanan berskala kecil dan sederhana, penyelidik telah menemu bual seramai 15 orang pengusaha premis makanan. Kesemua pengusaha premis makanan yang ditemu bual menjalankan beroperasi di tiga buah negeri iaitu Pulau Pinang, Kedah dan Perlis. Hal ini selaras dengan skop kajian yang hanya meliputi ketiga-tiga negeri tersebut. Pengusaha yang dipilih ini merangkumi tujuh jenis premis makanan. Premis-premis makanan tersebut ialah Restoran/ Kantin/ Kafe, Kafeteria Beroperasi di Medan Selera (Pengurusan Secara Berpusat), Kiosk, Katering/ Khidmat Penyajian Makanan/ Dapur Pusat Konvensyen/ Dapur Berpusat, Premis Bergerak (Yang Mempunyai Pengurusan/ Dapur Berpusat Sahaja) dan Kedai Bakeri/ Kek/ Pastrri.

Jadual 3: Latar belakang informan

Pengusaha	Jantina	Umur	Jenis premis makanan	Jenis perniagaan	Premis dimiliki	Jawatan	Tempoh premis beroperasi	Pengalaman Halal
A1	P	30	Kiosk	Kiosk	Muslim	Pemilik	4 Bulan	Tiada
A2	P	29	Restoran	Makanan/Minuman	Muslim	Pemilik	3 Tahun	Tiada
A3	L	55	Restoran	Yong tau foo/Masakan panas	Muslim	Pemilik	5 tahun	Tiada
A4	P	43	Kafe	Masakan Barat Panas	Muslim	Pemilik	3 tahun	Tiada
A5	P	44	Restoran	lauk campur/katering	Muslim	Pemilik	13 tahun	20 tahun
A6	L	32	Kafe	masakan Barat	Muslim	Pemilik	4 tahun	4 tahun
A7	L	TM	Kafe	/panas Masakan barat	Muslim	Pekerja	TM	Tiada
A8	P	25	Katering	Katering perkahwinan	Muslim	Pekerja	7 tahun	Tiada
A9	P	30	Medan Selera	Roti canai/Nasi Lemak	Muslim	Pemilik	30 tahun	Tiada
A10	P	43	Restoran	Makanan Thailand	Muslim	Pemilik	30 tahun	Tiada
A11	L	31	Kantin Sekolah	Makanan/Minuman	Muslim	Pemilik	5 tahun	5 tahun
A12	P	52	Bakeri	Kek dan biskut	Muslim	Pemilik	20 tahun	Tiada
A13	L	53	Kantin Kilang	Makanan/Minuman	Muslim	Pemilik	7 tahun	Tiada
A14	L	34	Premis Bergerak	Steamboat/locking	Muslim	Pekerja	5 tahun	Tiada
A15	P	36	Medan selera	Nasi campur	Muslim	Pemilik	Sebulan	2 Tahun

Latar belakang informan meliputi jantina, umur, jenis premis yang dijalankan, jenis perniagaan, premis dimiliki, jawatan, tempoh premis beroperasi dan pengalaman dalam halal. Jadual 3 menunjukkan latar belakang informan yang telah ditemui. Daripada 15 orang informan yang ditemui, 9 daripadanya adalah perempuan, sementara 6 yang lain adalah lelaki. Mereka semua berumur di antara 25-55 tahun.

Terdapat pelbagai jenis makanan yang dijual informan mengikut kesesuaian kategori premis makanan. Jenis makanan yang disediakan dan dijual oleh informan adalah seperti menjual makanan dan minuman, masakan panas, masakan barat dan nasi campur. Di samping itu, ada pengusaha yang menjalankan perniagaan katering perkahwinan dan menjual kek dan biskut. Selain itu, sebahagian pengusaha menjalankan perniagaan makanan masakan panas Thailand mahupun makanan tempatan.

Merujuk kepada Jadual 3 kesemua premis makanan ini dimiliki oleh orang Muslim. Seramai 12 orang informan merupakan pemilik kedai, manakala bakinya iaitu tiga informan adalah pekerja di premis makanan yang berkenaan. Tempoh premis beroperasi kebanyakan melebihi setahun kecuali premis makanan medan selera Bertam kerana baru beroperasi selama sebulan. Terdapat juga premis makanan yang telah beroperasi lebih daripada 10 tahun. Jadual 3 menunjukkan 5 buah premis yang telah beroperasi melebihi 10 tahun dan 10 buah premis makanan yang beroperasi kurang daripada 10 tahun.

Merujuk kepada Jadual 3 kebanyakan pengusaha tidak mempunyai pengalaman dalam halal, namun ada beberapa pengusaha yang mempunyai pengalaman dalam halal dalam tempoh 2-5 tahun pengalaman. Di samping itu, ada juga pengusaha yang mempunyai 20 tahun pengalaman dalam halal.

4.1 Isu Utama Kepatuhan Halal Dalam Operasi Premis Makanan Berskala Kecil Dan Sederhana

Bagian ini akan membincangkan dapatan bagi menjawab persoalan kajian pertama iaitu apakah isu utama kepatuhan halal dalam operasi premis makanan berskala kecil dan sederhana. Dapatan ini merupakan hasil daripada analisis data yang diperolehi daripada temu bual mendalam dengan informan kajian yang telah dijelaskan latar belakang mereka. Temu bual mendalam dengan informan bertujuan meneroka isu-isu kepatuhan halal dalam

kalangan pengusaha premis makanan. Kajian mendapati isu kepatuhan halal adalah seperti dalam perbincangan seterusnya.

4.1.1 Pengetahuan tentang konsep halal dan halal tayyiban

Isu pengetahuan tentang konsep halal dan halal tayyiban didapati mempunyai perkaitan dengan kepatuhan halal dalam kalangan pengusaha premis makanan. Dapatan kajian mendapati kebanyakan informan yang mempunyai pengetahuan yang baik tentang konsep halal, namun mereka kurang terdedah kepada konsep halal tayyiban. Daripada kajian ini, didapati informan A7 dan A4 amat jelas dengan konsep halal. A7 menjelaskan bahawa halal melibatkan empat elemen iaitu kesucian menurut hukum syarak, kebersihan, keselamatan dan berkualiti.

“Halal itu benda-benda yang bersih dari segi hukum syarak untuk kita makan kan...yang saya tahu la...kena bersih...suci...selamat.... dari segi kualiti tu kena bersih...dapur kena bersih” (A7)

Informan A4 pula menjelaskan bahawa mereka hanya menggunakan produk yang mempunyai logo halal dan produk keluaran Muslim. Umpamanya menggunakan Ayam BISMILAH dan NAFAS yang merupakan produk Muslim dan mempunyai logo halal JAKIM. Malahan informan A4 berusaha mengelakkan keraguan atau was-was dan ramuan yang kurang baik untuk kesihatan seperti ajinomoto. Hal ini menunjukkan kefahaman informan A4 tentang konsep halal dan halal tayyiban.

.. “sebab ada isu 20 tahun dulu, ada isu pasal penyembelihan ayam KFC, bila dah tau tak mau.” (A4)

“ .. semua produk Muslim, mee,..apa semua produk Muslim, ajinomoto kami tak pakai.” (A4)

“Halal tu kita faham la. Tiada unsur –unsur yang tak elok. Memang kita buat sendiri la dan tengok juga bahan tu halal. Titik beratkan kalau nak beli barang.” (A3)

Informan A9 pula menjelaskan bahawa selain daripada bersih, konsep halal menekankan kepada sumber atau ramuan dalam menghasilkan makanan. Ramuan yang digunakan untuk memasak mestilah halal di sisi Islam.

“Menurut saya halal itu halal dari segi kebersihan, dari segi makanan kita, halal dari sumber kita.” (A9)

Terdapat pula informan lain iaitu A8 yang menyatakan bahawa konsep halal dengan halal tayyiban hampir sama. Informan A9 pula menyatakan bahawa agak sukar untuk menjelaskan maksud halal tayyiban.

“Saya rasa halal dengan halal tayyiban adalah lebih kurang sama.” (A8)

“Macam tayyiban saya biasa dengar istilah tersebut tetapi saya tidak tahu macam mana nak terangkan balik.” (A9)

Secara keseluruhan, didapati kebanyakan informan mengetahui tentang halal namun, mereka kurang terdedah kepada istilah halal tayyiban.

4.1.2 Keperluan sijil halal kepada permis

Permohonan Pensijilan halal berbentuk sukarela di mana pengusaha diberi pilihan sama ada memohon pensijilan halal atau tidak (Mazuan & Zalina 2018; Iylia et al 2011). Kajian ini mendapati persepsi pengusaha terhadap keperluan pensijilan halal tidak memberangsangkan. Beberapa informan menyatakan bahawa kedai yang kecil dan sederhana tiada keperluan dalam memohon pensijilan halal.

“Mungkin dari segi depa pikir kedai terlalu sederhana ka...mungkin tak terlalu besar-besar...so depa nak mohon pun...depa kalau boleh dalam prosedur yang dari segi nak mohon tu senang...mungkin depa mohon...tapi tak dak la kedai besar macam mall ka KFC ka...nak pi mohon kan...so depa ada keinginan saya rasa la...tapi nak mohontu..banyak step.” (A10)

Di samping itu, pengusaha beranggapan bahawa kedai yang dikendalikan oleh orang Muslim tidak perlu memohon pensijilan halal. Pengusaha yakin dengan produk yang mereka keluarkan kerana mereka mengetahui tentang bahan dan ramuan yang digunakan dalam penyediaan makanan. Hal ini dinyatakan oleh informan A4 apabila ditanya tentang keperluan premisnya memohon pensijilan halal.

“Saya rasa tak perlu mohon sijil halal sebab saya rasa saya tau apa yang saya guna. Saya tak ambil produk lain (yang tidak halal), kalau kedai lain saya tak tahu.” (A4)

“Tak sampai tahap nak mohon la...lebih kurang macam tu la.” (A2)

“Kita rasa macam kita dah pakai barang yang kita buat sendiri...sebabyakin benda yang tiada logo...memang kita tak amik...kalau kita beli barang siam pun...kalau kita pi tengok barang tu tak dak logo halal tu...kita memang takamik”.(A3)

Hal ini selari dengan dapatan Zakaria Othman (2015) yang mendapati pengusaha mempunyai anggapan bahawa produk keluaran dari bumiputera Muslim mendapat keyakinan yang tinggi dari pengguna dan tidak perlu memohon pensijilanhala.

4.1.3 Kurang pengetahuan tentang proses permohonan Pensijilan Halal

Kajian ini mendapati informan mempunyai pengetahuan yang terbatas tentang proses permohonan pensijilanhala. Informan melaporkan bahawa mereka tidak mengetahui prosedur dan proses untuk memohon pensijilanhala. Informan A1,A3, A11 dan A14 menyatakan bahawa mereka tidak mengetahui cara atau prosedur untuk memohon pensijilan halal.

“Puan tahu tak macam mana nak apply halal?: saya tak tahu.” (A1)

“Adakah encik mengetahui tentang prosedur pensijilan halal tentang macam mana nak mohon? Kamarudin: tak tahu lagi.” (A3)

“Tapi ada dengar tak kut orang cakap susah tak cerewet ka? yang tu saya ada dengar masa pi kursus Jakim pasalpensijilan halal tu memang susah sikit.” (A4)

“Saya tak tahu prosedur...tapi saya rasa susah...ketat.”(A11)

“Untuk saya...mungkin saya tak cukup pengetahuan...sebab saya pekerja...saya tak ada kuasa untuk menguruskan” (A14)

Dapatan ini menyokong dapatan Saadan dan Safwan (2016), Baharudin et al. (2019) dan Syazwan et al., (2015) yang mendapati pengusaha tidak memohon sijil halal kerana mereka mempunyai kurang pengetahuan tentang pensijilanhala. Hal ini berpunca daripada kurang kesedaran terhadap pensijilan itu sendiri. Saadan dan Safwan (2016) menjelaskan hal ini turut berlaku kerana kurang atau tiada khidmat nasihat dan pendedahan dari agensi pembimbing usahawan. antara agensi pembimbing ialah agensi yang terlibat seperti MARA, SMECORP, MARDI dan sebagainya.

4.1.4 Proses permohonan pensijilan halal yang rumit

Di samping itu, proses permohonan pensijilan halal yang rumit dan susah menyebabkan pengusaha premis makanan tidak memohon pensijilan halal. Informan A6 beranggapan proses untuk memohon pensijilan halal susah dan mereka menghadapi masalah dari segi penyediaan dokumentasi untuk permohonan. Mereka berpandangan proses permohonan melibatkan proses audit yang sangat terperinci daripada hal-hal yang kecil sehingga hal yang besar. Kekangan masa dalam memohon sijil halal juga menjadi cabaran pengusaha dalam memohon pensijilan halal. Ini kerana mereka mempunyai pengetahuan yang terhad tentang proses dan prosedur untuk memohon pensijilan halal.

“Tapi ada dengar tak kut orang cakap susah tak cerewet ka? yang tu saya ada dengar masa pi kursus Jakim pasalpensijilan halal tu memang susah sikit.” (A4)

“Saya tak tahu prosedur...tapi saya rasa susah...ketat.”(A11)

“Untuk saya...mungkin saya tak cukup pengetahuan...sebab saya pekerja...saya tak ada kuasa untuk menguruskan” (A14)

“Tak ada sebab, susah tak nak minta halal.”(A10)

“Prosedur nak mohon step dia yang mendalam saya tak tahu sangat la, cuma dia cakap yang saya mohon tu dia boleh bantu la saya, untuk amik tu kan, sijil halal tu kan, sebab dia kata nak buat dari segi makanan perlu benda-benda macam tu, so saya dengar je la, saya dengar dan saya belajar dari benda-benda macam tu”.(A2)

“Sebab nak pi kursus tu la.nak buat kertas kerja tu la.nak buat dokumen.”(A12)

“Macam nak rekod bahan-bahan makanan tu dalam tu kan...kita tak ada masa...nak kira claim pun tak sempat...kalau semata-mata nak buat sijil tak payah rekod apa semua tu tak pa...memang tak sempat” (A13)

“Sebab banyak guidelines atau syarat-syarat tu. Tapi saya duk dengar orang cerita la kan nanti jadi fitnah pulak.” (A7)

“Sebab dari segi proses dia complicated juga walaupun possibility café ni kebanyakan milik muslim most barang dia dari supplier barang ada halal muslim punya produk tapi still lagi susah saya pernah apply” (A6)

“dari segi depa punya requirement depa nak datang buat spot check every detail ,every single pieces, every tinny-tinny pieces perlu tunjuk sijil halal dia kata so kalau kata cafe kita ada sijil grading A dari kementerian kesihatan basically kita dah lepas cuma belum bahagian majlis agama saja.” (A6)

“Kalau tengok dari segi online bagi orang yang ada sikit pengetahuan tu boleh la buat, Saya rasa bahawa apa yang di minta tu banyak sangat. Contoh macam saya nak dapatkan gula pun saya kena dapatkan sijil halal gula tersebut, maksudnya sesuatu ramuan yang saya pernah guna untuk masakan saya kena dapatkan halal ke tak gula tu. Terlampau banyak kareh.”(A8)

4.1.5 Proses permohonan pensijilan halal mahal dan mengambil masa

Kekangan masa dalam memohon sijil halal juga menjadi cabaran pengusaha dalam memohon pensijilan halal. Ini kerana mereka mempunyai pengetahuan yang terhad tentang proses dan prosedur untuk memohon pensijilan halal.

Mereka juga berpendapat kos yang tinggi dalam memohon pensijilan halal dan kekurangan masa menjadi cabaran dalam memohon pensijilan halal. Informan A2, A4 dan A7 berpendapat tentang kos yang tinggi dalam memohon pensijilan halal menyukarkan mereka untuk memohon. Kos bayaran pensijilan halal yang dikenakan adalah dua ratus Ringgit Malaysia bagi tempoh dua tahun.

“Rasa susah ke mahal ke? Puan: ya la.” (A2)

“kos dia mahal tak sebab dia ada fee:tak ingat tapi macam mahal saya tak ingat saya pi kursus 2014.” (A4)

“Dari segi kewangan kos...macam syarat-syarat tu depa duk mai check la...banyak la...pastu amik banyak masa...macam tu la saya dengar.” (A7)

“kita tak ada masa...nak kira claim pun tak sempat...kalau semata-mata nak buat sijil tak payah rekod apa semua tu tak pa...memang tak sempat...macam sijil halal ni macam maksudnya selalunya yang minta sijil halal tu taukey tu cina ke india kena minta sijil halal...tapi sebab tau taukey melayu...depa kilang ni tak kisah...sebenarnya nak mohon tu tak ada masalah...sebab nak rekod tu yang jadi masalah” (A13)

“Rasa tak ada masalah...tapi saya takut prosedur dia...masa lagi... sebab kita baru start operasi...niat ada...dengan kekangan masa lagi. sebab saya tak tahu harga tu berapa...tak tahu prosedur.” (A15)

Selain itu, kekurangan masa seperti yang dinyatakan oleh A13 dan A15, menyukarkan pengusaha untuk memohon pensijilan halal. Malahan, Fiteri dan Manisah (2015) mendapati pengusaha terpaksa menunggu masa yang lama untuk mendapatkan sijil halal. Melalui dapatan kajian ini, pengusaha premis makanan mempunyai pengetahuan yang terhad tentang kos pensijilan halal.

Dapatan ini selari dengan Zakaria Othman (2015) dan Ilyia et al., (2011) yang mendapati pengusaha yang tidak memohon pensijilan halal selalunya masih kekurangan sumber kewangan disebabkan oleh modal yang terhad dan kurang pengalaman dari aspek pengembangan perniagaan mereka. Justeru, walaupun yuran Pensijilan Halal adalah serendah RM200, mereka merasakan agak mahal, lebih-lebih lagi mereka sendiri tidak merasai keperluan memiliki logo halal.

5.0 KESIMPULAN

Kajian ini mendapati isu-isu dan pemasalahan berhubung pematuhan halal berkait rapat dengan persepsi terhadap keperluan; prosedur dan kos serta masa pensijilan halal. Dalam aspek keperluan pensijilan halal, kebanyakan informan menyatakan kurangnya keperluan untuk mendapatkan pensijilan halal memandangkan mereka merasakan bahawa mereka cakna tentang halal (*take for granted they are muslims*). Seterusnya, dalam aspek prosedur, informan rata-ratanya kurang berpengetahuan tentang cara-cara untuk memohon pensijilan halal. Didapati wujudnya kelemahan dari sudut pengaksesan informasi berkaitan halal dan pensijilan halal bagi sektor makanan industri kecil dan sederhana yang kerap dibincangkan dalam kalangan informan. Aspek terakhir dapatan kajian iaitu kos dan masa menunjukkan tema yang sering dibangkitkan oleh kebanyakan informan. Hal ini kurang dibincangkan dalam kajian lepas, rata-rata informan mengklasifikasikan kos dan masa sebagai kekangan untuk memohon pensijilan halal. Justeru, kajian ini telah menengahkan isu-isu dan permasalahan pematuhan halal dalam kalangan pengusaha premis makanan yang berbetntuk naratif. Dapatan daripada kajian ini dapat membuka ruang kajian ke arah memperhalusi prosedur pengurusan halal di Malaysia. Pihak JAKIM juga perlu menggunakan ruang dan peluang bagi penyaluran maklumat yang lebih berkesan berkenaan kepentingan pensijilan halal serta proses permohonan agar pengusaha premis makanan lebih cakna akan kepentingan dan seterusnya mendorong mereka untuk memohon pensijilan halal.

PENGHARGAAN

Penulis merakamkan setinggi-tinggi penghargaan kepada Kementerian Pendidikan Malaysia-FRGS (Kos s/o: 14194) di atas penawaran Dana Geran untuk penyelidikan ini. Kami juga mengucapkan terima kasih kepada Universiti Utara Malaysia dan semua pihak yang telah menyumbangkan kepada kejayaan menyempumakan penyelidikan FRGS ini.

RUJUKAN

- Aiedah Abdul Khalek. (2014). Young consumers' attitude towards halal food outlets and JAKIM's halal certification in Malaysia. *Procedia - Social and Behavioral Sciences*, 121, 26–34.
- Berita Harian. (2016). 'No pork' umpam pelanggan Islam. Dicapai pada 13 Julai 2020 daripada <https://www.klik.com.my/item/story/6752825/-no-pork-umpam-pelanggan-islam>
- Berita Harian. (2017). Pensijilan halal Malaysia sukarela, terbuka semua. Dicapai pada 13 Julai 2020 daripada <https://www.bharian.com.my/berita/nasional/2017/07/305557/persijilan-halal-malaysia-sukarela-terbuka-semua>
- Direktori Halal JAKIM, <http://www.halal.gov.my/ehalal/directory> diakses pada 30 Jun 2020
- Husna Hashim, Norma Md Saad, Haniza Khalid, Hayatullah Laluddin. (2019). Halal Compliance in Poultry Industry: A Review of Regulatory System in Malaysia. *International Journal of Academic Research in Business and Social Sciences*, 9(12), 486–494.
- Ilyia Nur Ab Rahman, Rosli Saleh, Suhaimi Ab Rahman and Dzulkifly Mat Hashim. (2011). Factors Contributing to Non-Compliance of the Halal Standard Among Restaurant Operators in Malaysia, 2nd International Conference on Business, Economics and Tourism Management, IPEDR, . Vol 24,88-92. Singapore: IACSIT Press.
- JAKIM. (2015). *Manual Prosedur Pensijilan Halal Malaysia (Semakan Ketiga)*. Jabatan Kemajuan Islam Malaysia. Putrajaya: Jabatan Kemajuan Islam Malaysia (JAKIM).
- JAKIM. (2019). *Draf Manual Prosedur Pensijilan Halal Malaysia (Domestik)*. Jabatan Kemajuan Islam Malaysia. Putrajaya: Jabatan Kemajuan Islam Malaysia (JAKIM).
- Mstar. (2019). Guna logo halal tanpa kebenaran, restoran masakan India terkenal dikompaun. Dicapai pada 13 Julai 2020 daripada <https://www.mstar.com.my/lokal/semasa/2019/01/16/logo-halal>
- Maa'mor Osman. (2003). "Kepentingan Makanan Halal dan Selamat ke Arah Keharmonian Masyarakat dan Negara". Kertas kerja dibentangkan dalam Seminar Kempen Makanan Halal dan Selamat. Kuala Lumpur, Januari.
- Nor Aini Haji Idris & Mohd Ali Mohd Noor. (2013). Analisis Keprihatinan Pengguna Muslim Terhadap Isu Halal-Haram Produk Melalui Pembentukan Indeks. *PROSIDING PERKEM VIII, JILID 3* (2013) 1245 – 12.
- Razali, Nor Ellyna and Ungku Zainal, Ungku Fatimah and Othman, Mohhidin and Mohamad, Siti Fatimah (2017) *Halal management system in restaurant operation : Identifying the motivational factors*. *Journal of Tourism, Hospitality & Culinary Arts (JTHCA)*, 9 (2). pp. 1-12
- Siti Khalilah Basarud-din, Azizi Abu Bakar, Ram Al Jaffri Saad. (2017). Pengaruh Faktor Agama dalam Mempengaruhi Gelagat Kepatuhan Pensijilan Halal Malaysia dalam Kalangan Ushawan Muslim. *Journal of Islamic, Social, Economics and Development*, Volume 2 (4), 94-101.
- [Savogo, D.S.](#) (2018), "Online traceability for halal product information: perceptions of Muslim consumers in Indonesia", *Journal of Islamic Marketing*, Vol. 9(1), 99-116.

- Sharifah Zannierah Syed Marzuki, Hall. C.M, Ballantine P.W. (2014). Measurement of Restaurant Manager Expectations toward Halal Certification Using Factor and Cluster Analysis. *Procedia - Social and Behavioral Sciences*, 121, 291-303. <https://doi.org/10.1016/j.sbspro.2014.01.1130>.
- SME Corp. Malaysia. (2015). SME Annual Report 2014/2015. In *SME Corp Malaysia*. <https://doi.org/10.1017/CBO9781107415324.004>

THE DETERMINANTS OF NON-FINANCING INCOME: AN ANALYSIS ON ISLAMIC BANKS IN MALAYSIA

Mohd Faizuddin Muhammad Zuki*

Islamic Business School, Universiti Utara Malaysia, Malaysia

Abstract

This study analyzes the determinants of non-financing income among the 10 selected Islamic banks in Malaysia. A comprehensive analysis of the 10 Islamic banks in Malaysia has been conducted over the period 2012 up to 2018. The main objective of this study is to examine the relationship between non-financing income for Islamic banks in Malaysia with determinants factors such as the size of the bank, core deposits from customers, return on asset and provision of loan losses. This study has adopted a few types of analysis methods including descriptive analysis, Pearson correlation analysis and multiple regression analysis to examine the relationship among all of the variables. Based on the findings of this study, all of the independent variables (the size of the bank, core deposits from customers, return on asset and provision of loan losses) are significant in determining the non-financing income for Islamic banks in Malaysia. It implies that Malaysia's Islamic banking sector still much depends on the size of the bank as this factor was the most influential in determining non-financing income followed by the provision of loan losses, core deposits from customers and return on asset. The findings also imply a consistency to previous studies from different background of bank's type and period covered.

Keywords: Non-financing income, bank's size, core deposits, return on asset, provision of loan losses

1.0 INTRODUCTION

Generally, the income structure for Islamic banking consists of two differences structures. Firstly, the income generates from traditional activities such as financing, dealing, and operating businesses, and secondly the income produced from non-traditional activities, for instance, non-financing activities. The incomes generated from non-traditional activities are generally identified as non-interest income in the conventional banking system and non-financing income in the Islamic banking system (Mat Isa et al., 2015). These two structures of income are the main sources of income for any Islamic banking industry. The incomes generated from financing activities such as home financing, personal financing, and vehicle financing for the retail sector or the incomes from the term trade, and working capital financing for the corporate sector. All of these activities have been categorized under the traditional activities of Islamic banks. Meanwhile, the incomes generated from non-financing activities such as fee-based activities, custodial services, and trading activities are another form of non-traditional activities for the Islamic banks.

There are few changing factors such as globalization, competition among financial institutions and global economic status forces the financial institutions or the banking industry to expand their income structures which vary from not only on traditional activities generating income as the main focus but non-financing income as well. This new operation's norm of the bank industries is not excluded the Islamic banks to take part as well. The non-traditional activities such as fee-based activity are considered as the diversification of the Islamic banks since these activities are not related to the traditional's operation of banking. Therefore, the diversification of the income structures gives the Islamic banks an additional income stream apart from traditional operating incomes. So, the Islamic banks as financial intermediaries are started to involve in the fee and services charges business which classified as the income from non-financing activities such as the contract of kafalah (guarantee), amanah (safekeeping), wakalah (agent), custodial services, brokerage, consulting and takaful. The importance of the non-financing income's shares to the banks' revenue now becomes more visible. This statement has been proved by the increases in profitability and the bank's value from all over the world (Stiroh, 2006).

Despite that, many of the banks worldwide indicate a significant remained unchanged on the trends of non-financing income's contribution, and it's devastating when some of the banks indicated a declining trend. This unfortunate event shows a starting point in the year 2004 amidst the Global Financial Crisis (GFC) and remained the trend at the time of revolution issue of the U.S Shale Oil in the year 2014. The oil revolution has given a bad impact in many ways and one of the most is the impact on growth domestic product (GDP) from all over the world.

Generally, prices of the oil affect the micro-economy side which is the levels of supply and demand (Soucek & Todorova, 2013). The price of the oil is depending on the demand as the oil demand has a direct relation with economic growth (Ghalayini, 2011). As an analogy, the price of the oil is increased when there is an increase in the growth of the economy as well as in the demand for oil and vice versa.

As such, the income and profitability of Malaysia's banking industry are moving in line with the pattern of economic activities. During that time, Malaysia's economy was affected by a significant moderate growth due to the domestic and external factors such as weaker oil prices. A report by Bank Negara Malaysia, states that the nominal gross domestic product was recorded at 7.7% for the year 2010 up to the year 2014 and has dropped to 6.9% for the year 2014 to the year 2018 (Sababathy & Shaharuddin, 2019). The same report mentioned that the profitability and non-financing income specifically for the banking sector in Malaysia also were at a low remark as 5.0% for the year 2010 up to the year 2014 and dropped to 3.8% for the next four years.

The contribution of non-interest income's share to total income for the UK banks has remained low at an average of 42% for 4 consecutive years. A report has mentions that Singapore banks have achieved and maintained at an average of 35% covered from the second half of 2016 to the first half of 2019 (PricewaterhouseCoopers, 2019). For the case of the Malaysian banking industry, the contribution of non-interest income to total income also has largely remained unchanged over time as well. A report by Bank Negara Malaysia has recorded 32.4% of non-interest income contribution in the year 2010 and stops at 31.5% in the year 2018 (Sababathy & Shaharuddin, 2019).

Several works of literature pay a lot of attention to the relationship between non-interest-based activities and the performance of banks in countries outside of Malaysia. However, similar attention has not been given much to the Islamic banking sectors in Malaysia. Thus, this study investigates the determinants factors of non-financing income for Islamic banks in Malaysia. This study intended to examine the significant variables in determining the share of non-financing income for Islamic banks in Malaysia. Besides, there is a lack of researchers to investigate the determinants of non-financing income on Islamic banks in Malaysia for the period after the GFC and U.S oil revolution. The study measures the influence of each variable such as the size of the bank, core deposits from customers, return on asset (ROA) and provision of loan losses on the share of non-financing income for the Islamic banks in Malaysia. Panel regression data analysis and annually data from 2012 to 2018 of Malaysia's Islamic banking sector are adopted to address the objective of this study. The findings indicate that the size of the bank is the most influential in determining the share of non-financing income for Islamic banks in Malaysia.

2.0 LITERATURE REVIEW

Another form of bank's revenue earns from outside operating income or any earning from the business of bank's traditional activities is the non-financing income (Khravish, 2011; Stiroh, 2006; Syafri, 2011). The traditional activities of the bank as an intermediary in offering loans and accepting deposits has been stably abated and more widespread onto non-traditional activities in form of offering fee-based services such as trade finance, foreign exchange, unit trust, fees of advisory service, investment banking, insurance, fiduciary, etc. (Brealey et al., 2011; Tortosa-Ausina, 2003). The traditional intermediation business of the banks such as offering loans and accepting deposits has been immovably descending particularly in the UK and US (Allen & Santomero, 2001). This is because of the increase in the importance of non-traditional activities that induce non-financing income such as commissions and fees with a bank's net operating income (Gichure, 2015; Gurbuz et al., 2013). These changes had permitted financial institutions to switch the traditional activities from a plain balance sheet intermediation with non-traditional activities which is bank diversification, for instance, activities based on fee-producing (Shahimi et al., 2006).

One of the main sources befitting of income for the banks is fee-based income (Smith et al., 2003). The income from fees and commission are the collections of income apart from operating activities, financing, and dealing business. This kind of income usually familiar as the non-interest income in the conventional banking sector, meanwhile it is considered as non-financing income in the sector of Islamic banking (Mat Isa et al., 2015). Since the payment and receipt of interest is prohibited in Islamic banking so this "other income" is referred to as non-financing income - that is, income unrelated to deposit-taking and loan granting (Molyneux & Yip, 2013). In Islamic banking, contracts such as *amanah*, *kafalah*, *ju'alah*, and *wakalah* are among the intermediaries' tools of the Islamic financial institution to perform the economic activities either for retail sectors or corporate sectors (Shahimi et al., 2006).

A study suggests that large banks that are fully equipped with new technology exhibit to have cost-saving and more efficiency in gainings (Hunter & Timme, 1986). The usage of new financial technologies (fintech) also allowed banks to create new revenue streams through non-financing income (Hakimi et al., 2015). A comprehensive analysis conducted by Hahm (2008) on 662 relatively large commercial banks from 29 OECD countries for the period of 1992 to 2006 found that the banks with larger assets tend to have higher non-financing income ratios (Hahm, 2008). Rogers & Sinkey (1999) analyze the non-traditional activities in U.S commercial banks find that the size of the bank is unmistakably associated with non-financing income. They mentioned that the size of the bank is an important variable so that the interpretation of other variables could be done (Rogers & Sinkey, 1999). A comprehensive analysis conducted by Alper & Anbar (2011) on the impact of bank-specific and profitability for the 10 of Turkey's commercial banks found for a fact and significant result between bank size and profitability of the bank. The study suggests that the bank size could improve the bank profitability when credit ratio is decreased (Alper & Anbar, 2011).

Exploring the existing studies of the impact bank size on the non-financing income for the Islamic banking industry, Shahimi et al., (2006) in their study on Malaysian Islamic commercial banks from 1994 to 2004. The findings show that there is a positive and remarkable relationship between a total asset (to capture the size of the bank) and the share of the non-financing income (fee). The findings also indicate that a grander bank can foster more fee income for the bank. This is due to the nature of the large bank where the bank able to use new technology and have cost-saving operations. As a conclusion, there is a strong and remarkable impact between non-financing income and the size of the bank. This statement has been proved by many previous studies where the larger size of the bank, the larger is the total of non-financing income level at a bank.

As been mentioned by Rogers & Sinkey (1990) in their study, the level of nontraditional activities at a bank might also be affiliated to the structure of its liability. They proposed that, if a bank constrained in the volume of core deposits it can attract, it may produce a larger quantity of nontraditional activities concurrently with finding other sources of funds. An analysis has been conducted on the contribution of the non-financing income share for the 20 commercial banks in Ghana for the period 2002 to 2011. The findings show that when smaller banks with lower deposit shares are highly involved in non-traditional activities that generate non-financing incomes (Damankah et al., 2014). It's contrary to the findings from the study that has been conducted by Bailey-Tapper (2010) on the non-financing income, financial performance, and macroeconomy from Jamaican panel data for the period 1999 to 2010. The study found a negative relationship between core deposits and non-financing income levels. They suggest that the negligence of the bank on the closed-relationship with the customers (Bailey-Tapper, 2010). Unfortunately, there is a lack of empirical study of the impact of core deposits on the non-financing income level for the Islamic banking industry. An analysis conducted by Shahimi et. al., (2006) on fee income activities in Malaysian Islamic commercial banks for the year 1994 to 2004. The findings indicate when the banks are highly engaged with fee-based activities to tend to have a significant relationship with the core deposits level. They propose that the bank with highly involved in core deposits will generate more non-financing income.

Many studies have proved and indicated a positive and significant relatable link between the non-financing income and the profitability of the bank. Therefore, indirectly, it also has a positive and significant relationship with the level of return on assets (ROA). Saunders et. al., (2016) included two types of accounting return measures in their research to measure the profitability of the U.S. bank which is the return on asset (ROA) and return on equity (ROE) (Saunders et al., 2016). A study conducted by Hahm (2008) to examine the determinants and consequences of non-financing income diversification on commercial banks in OECD countries. The results indicate that the banks with highly engaged in non-financing income tend to exhibit a higher ROA level. Another study has been done to investigate the importance of non-financing income on the financial performance of commercial banks in Barbados between 1985 and 2001. They found that non-financing income level in Barbados commercial banks positively affected on ROA (Craigwell & Maxwell, 2015).

Another study held to investigate the income structure and profitability on the 8 Asian banks over the period 2005 to 2011. An interesting finding found that the net non-financing income increases the bank's market risk and asset risk but reduce insolvency risk, ROA, and ROE. The interesting part is when the bank has a higher exposure to net income from commissions and fees could increase insolvency risk, ROA, and ROE (Chunhachinda & Li, 2014). Reviewing the previous existing studies on the impact of non-financing income and the return on assets within the Islamic banking sector seems to be difficult due to inadequate amount of study. A comprehensive study conducted to examine the impact of income diversification on the performance of Islamic banks in Malaysia, Saudi Arabia, Kuwait, Qatar, Bahrain, and the UAE for the period 1997 to 2009. The results indicate that the share of non-financing income (familiar as the non-interest income in the traditional (conventional) banking system) has a significant relationship with the ROA. The study also has suggested that the more non-financing income is generated, it will boost profits and performances (Molyneux & Yip, 2013).

Another determinant that could influence non-financing income is the provision of loan loss. Rogers & Sinkey (1999) have defined the provision of loan loss as “a non-cash outlay that flows through a bank’s income-expense to a contra-asset account on the balance sheet called the loan-loss reserve or allowance for loan and lease losses” (Rogers & Sinkey, 1999). A study conducted to assess bank risk and product diversification in the European banking industry for the period 1996 to 2002. The previous studies ascertained that the banks which highly engaging with non-traditional activities were associated with higher risk (Lepetit et al., 2008). Again, Demirguc-Kunt & Huizinga (2010) in their study found a direct relationship between fee income activities and bank’s risk as the increase of fee income activities leads to an increase in the bank’s risk. Another study conducted to investigate the effect of non-financing income on the bank’s risk for some Iranian banks over the period 2006 to 2011. The regression estimation analysis yielded that the non-financing income is positively related to the bank’s risk as well as return on equity (Fengju et al., 2016).

Lee et al., (2014) in their research conducted to investigate the impacts of non-financing income on risk among 967 individual banks from Asia region as much as 22 countries for the period 1995 to 2009. The results show different relationships which are dependent on each bank’s specialization and countries’ income level. For saving banks, non-financing income increases the risk of the bank whereas for the last two types; corporate and investment banks, non-financing income does not increase the risk of the bank. Meanwhile, non-financing income in high-income level countries increases the bank’s risk and contradicts to middle and low-income countries (Lee et al., 2014).

Exploring the literature studies relating to the relationship between non-financing income and risk that captures by the provision of loan loss, a study was conducted among Islamic commercial banks in Malaysia over the period 1994 to 2004. The findings indicate that banks with high engagement in non-traditional activities tend to exhibit less (Shahimi et al., 2006). The study also suggests that the diversification of the bank into non-traditional activities tend to be safer. Another word of explanation, it means there is a negative relationship between these two variables. A regression analysis data has been done to inspect how fee income and risk are related to each other for the Islamic banks in Malaysia over the period 2008 to 2013. The findings show that the total risk of the bank can be reduced by getting involved in fee income activities (Mat Isa et al., 2015).

3.0 METHODOLOGY

To examine the determinants of non-financing income, this study has been used as a quantitative research method since all the variables are measurable. To be more precise this study uses cross-sectional analysis because this research leads to look at data from a population at one specific point in time on the variables (size of the bank, core deposits from customers, return on asset and provision of loan losses) towards the share of non-financing income on the 10 selected of Islamic banks in Malaysia. This study has chosen 10 Islamic local banks in Malaysia and will analyze how all the variables will impact on the non-financing income of these 10 Islamic banks. The period covered for this analysis is from 2012 up to 2018. This study has been used the secondary data which is obtained from the DataStream content provider by Thomson Reuters, Fitch Solution and bank’s financial reports. All of the data either for dependent and independent variables that are available in the DataStream providers have been dug out from the bank’s financial reports which are published on an annual basis. All of the selected Islamic banks are under the regulation of Bank Negara Malaysia (BNM). Therefore, the validity of the data is reliable. This theoretical framework of this study is adopted from Rogers & Sinkey (1999).

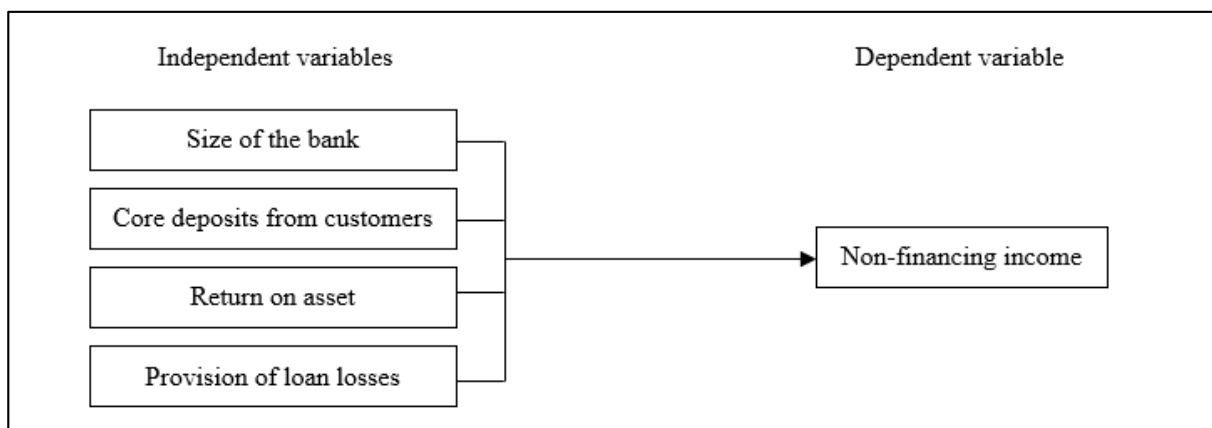

Fig. 1. Theoretical framework

This study is lead to examine all possible determinants that could influence the level of non-financing income share for Islamic banking in Malaysia. So, this study has been adopted the following empirical equation:

$$NFI_{it} = \alpha + \beta_1 SIZE_{it} + \beta_2 DEPOSIT_{it} + \beta_3 ROA_{it} + \beta_4 PROV_{it} + \varepsilon_{it} \quad (1)$$

NFI_{it} is the dependent variable for the net total of non-financing income (fee and commission income) over total operating income (Köhler, 2013; Rogers & Sinkey, 1999). $SIZE_{it}$ is the independent variable of the logarithm for the bank's total assets (Shahimi et al., 2006). It is employed to capture the size of the bank (Busch & Kick, 2009). $DEPOSIT_{it}$ is the independent variable for the total deposit from customers over total assets (Rogers & Sinkey, 1999; Shahimi et al., 2006). ROA_{it} is the independent variable for the total net income over average assets (Bailey-Tapper, 2010; Chunchinda & Li, 2014; Ozek, 2016). $PROV_{it}$ is the independent variable for the total provisions of loan losses over the total asset (Ozek, 2016; Rogers & Sinkey, 1999).

4.0 FINDINGS AND DISCUSSIONS

Table 1 illustrates the results of the descriptive analysis for the Islamic banks in Malaysia. The descriptive analysis summarizes the entire data and gives us an overall idea to the population of the study. This analysis will point out the value of mean, median, standard deviation, skewness and kurtosis for each variable. The function of the descriptive analysis is to identify whether the obtained data are distributed in a normal way or otherwise. The findings shown in Table 1 implies that the data was not normally distributed. There is a positive kurtosis which is DEPOSIT.

Table 1. Descriptive analysis

	NII	ASSET	DEPOSIT	ROA	PROV
Mean	3.953	6.584	10.437	10.200	5.537
Median	4.006	6.632	10.482	10.187	5.509
Std. Deviation	1.074	0.790	0.795	0.780	0.896
Variance	1.154	0.624	0.632	0.608	0.803
Skewness	0.009	0.105	0.148	0.164	0.100
Kurtosis	-0.922	-0.486	0.041	-0.050	-0.516

Table 2 indicates the Pearson correlation analysis to examine the relationship between the dependent variables and each of independent variables and relationship among the independent variables. Based on Table 2, it illustrates that all of the independent variables are indicates that the coefficient value lies between 0.50 and 1.0 which reflects a strong and positively correlated with non-financing income for all of the 10 Islamic banks in Malaysia. This implies that changes in one variable are strongly correlated with changes in the second variable. Besides, it means that the dependent variable is moving in one direction with the independent variables. The dependent variable is affected which increases as the independent variables are increased. Moreover, it is clearly stated that the highest "Pearson r" correlation analysis is the ASSET at 0.935, which was included to capture the size of the bank. Its suggests that the bank's size has the biggest influence in increasing the share of non-financing income in Islamic banks in Malaysia. The next impactable factors are the ROA, DEPOSIT and PROV at 0.889, 0.884 and 0.870 respectively. To conclude, all of the selected independent variables in this study present an important role in determining the level of non-financing income in Islamic banks in Malaysia.

Table 2. Pearson correlation analysis of variables for Malaysia's Islamic banks

	NII	ASSET	DEPOSIT	ROA	PROV
NII	1				
ASSET	.935**	1			
DEPOSIT	.884**	.955**	1		
ROA	.889**	.969**	.993**	1	
PROV	.870**	.966**	.958**	.962**	1

** . Correlation is significant at the 0.01 level (2-tailed).

Table 3 reports the multiple regression results to examine the most significant determinant influencing the level of non-financing income for Malaysia's Islamic banks. Table 3 illustrates the result of the multiple regression analysis. It indicates that F value was produced at (F=153.116) and significant at (p=0.000). Moreover, the value of R^2 in this study was 0.904 which means 90.4% of the variance in determining the non-financing income had been explained by all of the independent variables such as the size of the bank, core deposit from the customer, return on asset and provision of loan loss.

Referring to Table 3, it reports that all of the independent variables are significant relations with the level of non-financing income. The size of the bank shows significant at 0.000 with the value of Beta is 2.240 and t value at 8.651. Besides, core deposit from the customer also produced a significant at 0.006 with the value of Beta and t at 1.324 and 2.816 respectively. Followed by return on asset represented a significant result which is at 0.009, Beta value at -1.499 and t value at -2.711. Last but not least, there is a significant value at 0.001 for provision of loan loss and associated with negatives value for Beta and t value at -0.737 and -3.635 respectively.

Table 3. Multiple regression analysis

Explanatory variables	Coefficient Beta	t	Sig.
(Constant)	-5.244	-4.608	.000
ASSET	2.240	8.651	.000
DEPOSIT	1.324	2.816	.006
ROA	-1.499	-2.711	.009
PROV	-.737	-3.635	.001

R Square : **0.904**

F Value : **153.116**

Significant : **0.000**

As a conclusion, all of the independent variables such as the size of the bank, core deposit from the customer, return on asset and provision of loan loss have a significant relationship and the most influential factors in determining the non-financing income for Islamic banks in Malaysia. The size of the bank indicates the most influential factor in determining the non-financing income followed by the provision of loan loss, core deposit from customer and the last one was the return on asset. Based on multiples regression results, the empirical model of this study can be concluded as follows:

$$\text{Log NFI} = -5.244 + 2.240 (\text{Log ASSET}) + 1.324 (\text{Log DEPOSIT}) - 1.499 (\text{Log ROA}) - 0.737 (\text{Log PROV}) \quad (2)$$

The significant result for the size of the bank is consistent with the study that has been done by Rogers and Sinkey (1999) where they found that the size of the bank positively correlated and significant with non-financing income for U.S commercial banks. The result also aligns with the findings that have been obtained by Hahm (2008) when conducting a study on commercial banks from 29 OECD countries as the bank with large assets is likely to have a higher share of non-financing income. More interesting, the size of the bank remained significantly related to the non-financing income over the year when a study was conducted to analyse the impact of bank size for the Islamic commercial banks in Malaysia over period 1994 to 2004 (Shahimi et al., 2006). This reflects that Islamic banks in Malaysia still very much focusing on the size of the bank.

The result for core deposit from customer also implies a significant relationship with non-financing income level. It found to be consistent with the study on the same topic area for commercial banks in Ghana for the period 2002 to 2011 by Damankah et al., (2014). It also in parallel with the findings of a study done by Shihimi et al., (2006) on Malaysian Islamic commercial banks. Surprisingly, the finding is contrary to the study done by Bailey -Tapper (2010) where core deposit for Jamaican banks is negatively related to the non-financing income.

Another significant factor in determining the level of non-financing income of the Islamic banks in Malaysia is the return on asset. This significant factor seems to be in line with the findings of the studies done by Hahm (2008), Craigwell & Maxwell (2015), Bailey-Tapper (2010), Chunchinda & Li (2014) and many more when analyzing the impact of ROA on non-financing income. Most previous studies concluded that there are positive correlation and relationship between ROA and non-financing income.

5.0 CONCLUSIONS

Globally, the banking system diversified its banking activities by considering non-traditional activities into the operation. The shifts to non-traditional activities have increased the contribution of non-financing income into the bank's revenue. This contribution of the non-financing incomes for the banks becomes the best solution to cover the reduction of the income share from traditional business activities and assist to increase exceeding half of a bank's operating revenues (Matthews & Thompson, 2005). This paper analyzes the determinants of non-financing income for Islamic banks in Malaysia. Using banks' panel data from 2012 to 2018, it indicated that the Islamic banks in Malaysia still much focused on the size of the bank as this factor is the most influential in determining the share of non-financing income.

The contribution of non-financing income for Malaysia banking industry was at 35% of overall income. The component of non-financing income also shows a crucial role as traditional income for bank's revenue. For that reason, we should consider the important non-financing income's contribution to diversifying the operation of the bank. Without any doubt, non-financing income is one of the important sources for the bank's revenue and increases the stream of bank's income. So, further study on other factors that have potential in determining the non-financing income for Islamic banking in Malaysia should be done. The future research also should implement a different analysis method such as Trend analysis, Unit Root analysis, Co-integration analysis and Variance Decomposition analysis to have different interpretation on the nature of non-financing income.

REFERENCES

- Allen, F., & Santomero, A. M. (2001). What do financial intermediaries do? *Journal of Banking and Finance*, 25(2), 271–294. [https://doi.org/10.1016/S0378-4266\(99\)00129-6](https://doi.org/10.1016/S0378-4266(99)00129-6)
- Alper, D., & Anbar, A. (2011). Bank Specific and Macroeconomic Determinants of Commercial Bank Profitability: Empirical Evidence from Turkey. *Business & Economics Research Journal*, 2(2), 139–152.
- Bailey-Tapper, S. (2010). *Non-interest Income, Financial Performance & the Macroeconomy: Evidence on Jamaican Panel Data*.
- Brealey, R. A., Myers, S. C., & Allen, F. (2011). Principles of Corporate Finance. In *McGraw-Hill* (10th ed.). McGraw-Hill. <https://doi.org/10.2307/2327568>
- Busch, R., & Kick, T. (2009). Income Diversification in the German Banking Industry. In *SSRN Electronic Journal* (Issue 09). <https://doi.org/10.2139/ssrn.1342282>
- Chunhachinda, P., & Li, L. (2014). Income structure, competitiveness, profitability, and risk: Evidence from Asian banks. *Review of Pacific Basin Financial Markets and Policies*, 17(3). <https://doi.org/10.1142/S0219091514500155>
- Craigwell, R., & Maxwell, C. (2015). *Non-Interest Income and Financial Performance at Commercial Banks in Barbados*. 30(3), 309–328.
- Damankah, B. S., Anku-Tsedo, O., & Amankwaa, A. (2014). Analysis of Non-Interest Income of Commercial Banks in Ghana. *International Journal of Academic Research in Accounting, Finance and Management Sciences*, 4(4), 263–271. <https://doi.org/10.6007/ijarfn/v4-i4/1343>
- Fengju, X., Yari Fard, R., Yari Fard, S., & Ehsan Maleki, S. (2016). The relationship between risk and return and banks income structure. *European Online Journal of Natural and Social Sciences*, 2(3(s)), 124–129.
- Ghalayini, L. (2011). The Interaction between Oil Price and Economic Growth. *Middle Eastern Finance and Economics*, 13, 15.
- Gichure, K. S. (2015). *The Relationship Between Non Interest Income and Financial Performance of Commercial Banks in Kenya* (Issue November).
- Gurbuz, A. O., Yanik, S., & Ayturk, Y. (2013). Income Diversification and Bank Performance: Evidence From Turkish Banking Sector. *Journal of BRSA Banking and Financial Markets*, 7(1), 9–29.
- Hahm, J.-H. (2008). Determinants and Consequences of Non-Interest Income Diversification of Commercial Banks in OECD Countries. *SSRN Electronic Journal*, 12(1), 3–32. <https://doi.org/10.2139/ssrn.3077837>
- Hakimi, A., Hamdi, H., & Djelassi, M. (2015). *Modelling Non-Interest Income At Tunisian Banks* (Issue 65114).
- Hunter, W. C., & Timme, S. G. (1986). Technical Change, Organizational Form, and the Structure of Bank Production. *Journal of Money, Credit and Banking*, 18(2), 152–166. <https://doi.org/10.2307/1992199>
- Khrawish, H. A. (2011). Determinants of Commercial Banks Performance: Evidence from Jordan. *International Research Journal of Finance and Economics*, 81, 19–45.
- Köhler, M. (2013). Does non-interest income make banks more risky? Retail- versus investment-oriented banks. *Review of Financial Economics*, 17(4), 182–193. <https://doi.org/10.1016/j.rfe.2014.08.001>
- Lee, C. C., Yang, S. J., & Chang, C. H. (2014). Non-interest income, profitability, and risk in banking industry: A cross-country analysis. *North American Journal of Economics and Finance*, 27, 48–67. <https://doi.org/10.1016/j.najef.2013.11.002>
- Lepetit, L., Nys, E., Rous, P., & Tarazi, A. (2008). Bank income structure and risk: An empirical analysis of European banks. *Journal of Banking and Finance*, 32(8), 1452–1467. <https://doi.org/10.1016/j.jbankfin.2007.12.002>
- Mat Isa, S. S., Ma'in, M., & Hanif, A. (2015). Islamic bank's fee income and risk: Evidence from Malaysia. *Advanced Science Letters*, 21(5), 1546–1549. <https://doi.org/10.1166/asl.2015.6097>
- Matthews, K., & Thompson, J. (2005). The Economics of Banking. In *John Wiley & Sons Ltd*. <https://doi.org/10.1017/CBO9781107415324.004>
- Molyneux, P., & Yip, J. (2013). Income diversification and performance of Islamic banks. *Journal of Financial Management, Markets and Institutions*, 1, 47–66. <https://doi.org/10.12831/73632>
- Ozek, P. (2016). Non-Traditional Activities and Funding Structures: An Analysis of Commercial Banks in Turkey. *Uluslararası İktisadi ve İdari İncelemeler Dergisi*, 1(18), 53–70.
- PricewaterhouseCoopers. (2019). *Bucking the trend: Singapore Banking Review* (Issue October).
- Rogers, K., & Sinkey, J. F. J. (1999). An analysis of nontraditional activities at US commercial banks. *Review of Financial Economics*, 8, 25.
- Sababathy, H., & Shaharuddin, S. H. (2019). Malaysian Banks' Profitability – Past Trends and Future Prospects. In *Financial Stability Review - First Half 2019* (Vol. 1, pp. 35–43).
- Saunders, A., Schmid, M., & Walter, I. (2016). *Non-Interest Income and Bank Performance: Does Ring-Fencing Reduce Bank Risk?* (2014/17).
- Shahimi, S., Ismail, A., & Ahmad, S. (2006). A Panel Data Analysis of Fee Income Activities Islamic Banks. *Journal of King Abdulaziz University-Islamic Economics*, 19(2), 23–35. <https://doi.org/10.4197/islec.19-2.2>
- Smith, R., Staikouras, C., & Wood, G. E. (2003). Non-Interest Income and Total Income Stability. *SSRN Electronic Journal*. <https://doi.org/10.2139/ssrn.530687>
- Soucek, M., & Todorova, N. (2013). Economic significance of oil price changes on Russian and Chinese stock markets. *Applied Financial Economics*, 23(7), 561–571. <https://doi.org/10.1080/09603107.2012.732685>
- Stiroh, K. J. (2006). A Portfolio View of Banking with Interest and Noninterest Activities. *Journal of Money, Credit and Banking*, 38(5), 1351–1361.
- Syafri. (2011). Factors Affecting Bank Profitability in Pakistan. *The 2012 International Conference on Business and Management*, September, 61–87.
- Tortosa-Ausina, E. (2003). Nontraditional activities and bank efficiency revisited: A distributional analysis for Spanish financial institutions. *Journal of Economics and Business*, 55(4), 371–395.

MAQASID AL-SHARIAH IN DEBT MANAGEMENT – A SYSTEMATIC LITERATURE REVIEW

Mohd Afifie Mohd Alwi^a, Azwan Abdullah^b & Azyanee Luqman^c

^{ab} *Fakulti Keusahawanan dan Perniagaan, Kampus Kota, Universiti Malaysia Kelantan, Malaysia*

^b *Fakulti Pengurusan dan Perniagaan, Universiti Teknologi MARA Cawangan Kelantan, Malaysia*

Abstract

Debt is a thoughtful matter in Islam and should not be commenced except for real necessity. Hence the present study reviewed past studies on consumer debt management from the perspective of *maqasid Shariah*. Guided by the RAMESES review method, a systematic review identified only six related studies throughout Scopus and Web of Science. After going through the theme analysis process, four main research themes emerged: accruing debt, debt behaviour, equity versus debt, and *maslahah* (benefit) & *mafsadah* (mischief). In-depth qualitative studies of *maqasid Shariah* in debt management are strongly recommended.

Keywords: Debt management, *maqasid Shariah*, *maslahah*, *mafsadah*, debt behavior.

1.0 INTRODUCTION

The availability of debt financing nowadays derails individual from living as-is basis especially in a consumerism society which enjoys beyond the comfortable standard of living by having basic needs such as a house, vehicle, appliances, fancy gadget, and other complementary items because applying for credit is easily available (Yusoff et al., 2000; Buang, 2009). The impact of the acquisition of debt has been found negatively affected the financial well-being, such as bankruptcy filings, which tarnished the benefits of this credit availability (Rahman et al., 2020). Various reports showed that some people are unintentionally entangled in debt or taking debt financing to fulfil a more comfortable standard of living. Likewise, others get credit for business or expanding their business empire. Nevertheless, the amount of debt required must be proportional to income earned (Zainol et al., 2016). However, the propensity towards indebtedness becomes more complicated in Malaysia. This is based on the study conducted by Azma et al. (2019) concluded that, self-control is a statically significant key to avoid indebtedness since people are not always rational when come to materialism.

On the other hand, Mokhtar and Ismail (2013) opined that instead of Islamic financial institutions have an essential role as a sole provider to making Shariah-compliant available funds to the Muslims, they have argued that the debt provided by institutions was not solidly driven by necessity and complementary benefit needs. As a matter of fact, some individuals acquire debt for embellishment purposes and to accumulate wealth. Therefore, it is something to ponder how the individual comprehends and adapts the actual goals as a Muslim to the objectives of *Shariah* accordingly.

1.1 Research gap

The writing of many Muslim jurists have addressed the issue of debt acquisition in term of *maqasid Shariah* explicitly or implicitly. According to Mohd Al-Bakri (2015), debt and borrowing activities should only occur for genuine need or in a state of emergency. Islam puts the requirement that debt acquisition depends on the level of need as outlined by the objectives of *Shariah* (*maqasid Shariah*) (Ali et al. 2018). Moreover, debt is not a despicable thing in Islam, but its purpose should be in the matter to increase self-esteem, and it depends on one's current situation (Toto Ngadiman et al., 2019). As with the requirements of Islamic *Shariah*, *maqasid Shariah* has its own meaning in determining and considering a matter in order to ensure the benefits and reject the difficulties (Zainal Abidin et al., 2016 ; Azhar et al., 2017). This proves that studies related to the *maqasid Shariah* have been widely discussed in various studies such as economics, banking, and finance (Shinkafi & Ali, 2017). However, there are still lacking efforts to review on *maqasid Shariah* in debt management systematically. This study endeavours to fill the gap in understanding the research on this topic. Fulfilling the empirical gap, domain and variables derived from this study could come up as new knowledge for future study. Other than that, this systematic review should easily provide a reference for future studies related to any information on the topic.

2.0 METHODOLOGY

2.1 The review protocol - RAMESES

This study employed a review protocol as information searching databases (Scopus and Web of Science) practiced by Wong et al. (2013) called RAMESES (Realist and Meta-narrative Evidence Syntheses: Evolving Standard). Based on RAMESES guidance and suggestion, several vital points, namely, abstract, introduction, methods, results, and discussion section, should include in detail for the review process, search process, and document selection. RAMESES is a compatible systematic review of literature in social science in because; first, it clearly defines the research questions, facilitates the identification of criteria to include or exclude items and lastly the attempt to examine primary databases of scientific literature review within a specific time (Samsuddin et al., 2020). RAMESES enables the rigorous search of terms based on a variety of research designs related to study in the adaptation of *maqasid Shariah* in debt management. It also allows the coding of valuable information for future research and reviews, and this method can monitor research patterns and trend in debt management.

2.2 Formulation of research questions

This study adopted the formulation of a research question based on PICO. PICO is a tool that helps authors to create the right research question for the review (Mohamed Shaffril et al. 2020). PICO is based on the concept of Population or Problem, Interest, and Context, which is included in three aspects in the review, namely debt management (Problems), *maqasid Shariah* (Interest), and Muslim community in Asia (Context), which then directed to the main research question – What is the adaptation of *maqasid Shariah* in debt management among the Muslim community in Asia.

2.3 Systematic searching strategies

The systematic searching strategies consist of three main processes, which are identification, screening, and eligibility, to enhance retrieving articles (refer figure 1). This process assisted the authors in the process of removing duplicated articles after the screening stage.

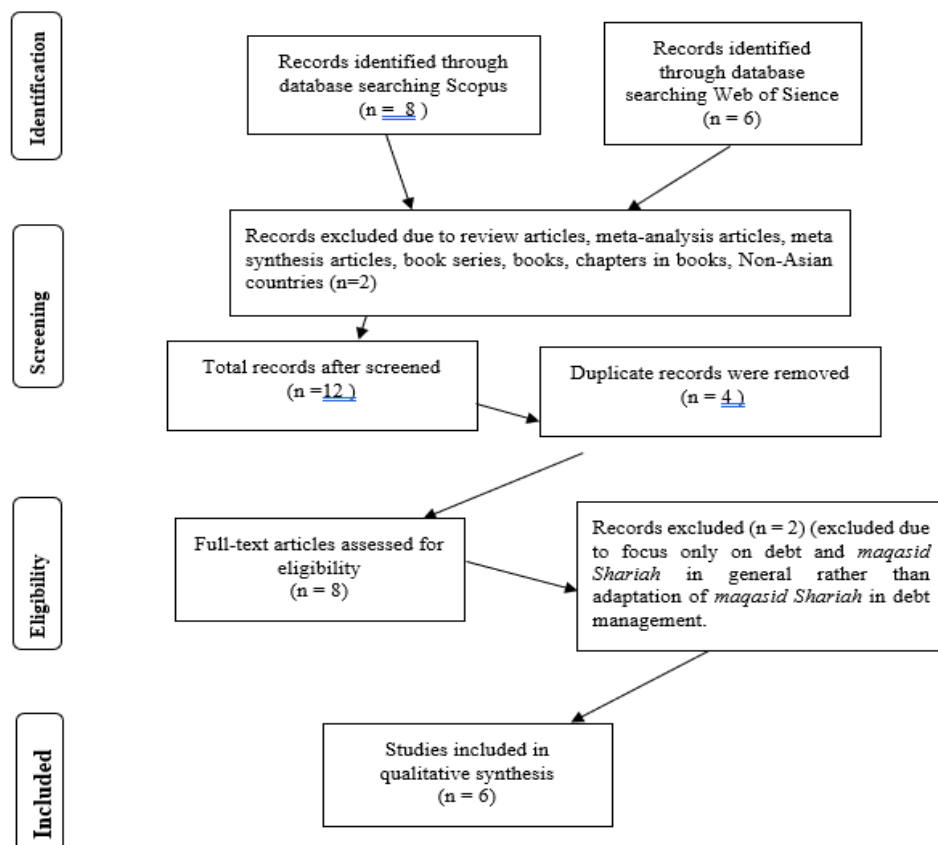

Fig. 1. The flow diagram of the study (adapted from Mohamed Shaffril et al., 2019)

2.3.1 Identification

Identification is a process to conduct searching for any synonym, related terms, and variation for the main keywords for the study of debt management which are *maqasid Shariah*, and the Muslim. It purposely gives more variety of selected database for more related articles for the review. The author develops keywords in the research question as suggested by Okoli (2015), and the identification process depends on the online thesaurus, keywords used by the previous study, and keywords suggested by Scopus. Thus, the author managed to enhance the existing keywords and construct full research string (based on Boolean operator, phrase searching, and truncation) on Scopus and Web of Science (Table 1). Scopus and Web of Science are two databases that able to provide advanced searching functions, comprehensive (indexing more than 5000 publishers), it controls the articles' quality and multidisciplinary subjects (Martín-Martín et al., 2018). The combination of keywords such as "debt management" and "*maqasid Shariah*," was applied whenever appropriate via the function of phrase searching and Boolean operator (OR, AND). Eventually, searching in these two databases resulted only 14 articles related found.

Table 1. The Search String.

Database	Search String
Scopus	TITLE-ABS-KEY (("debt manage*" OR "debt" OR "pengurusan hutang") AND (" <i>maqasid al-shariah</i> " OR "objective* of shariah" OR " <i>maqāsid al-sharī'a</i> " OR " <i>Maqasid Al-Shari'ah</i> " OR "objektif syariah" OR " <i>maqasid shariah</i> " OR " <i>maqasid Syariah</i> "))
Web of Science	TS= (("debt manage*" OR "debt" OR "pengurusan hutang") AND (" <i>maqasid al-shariah</i> " OR "objective* of shariah" OR " <i>maqāsid al-sharī'a</i> " OR " <i>Maqasid Al-Shari'ah</i> " OR "objektif syariah" OR " <i>maqasid shariah</i> " OR " <i>maqasid Syariah</i> "))

2.3.2 Screening

Screening is a process to include or exclude articles that have been decided in the previous discussion supported by a specific database. This process aimed to find relevant articles to be included in the systematic review (Table 2). First, in terms of the timeline, authors selected from the years 2010 to end of June 2020, which is based on a total number of related publications retrieved to be reviewed. The second inclusion criteria were to ensure the quality of the review, article journal with empirical data, and published in a journal were selected. On the other hand, review articles, books, and chapters in the book were excluded. Moreover, only articles published in English and Malay are included in the review to avoid unnecessary misunderstanding. This process resulted in 12 articles.

Table 2. The inclusion and exclusion criteria.

Criterion	Inclusion	Exclusion
Timeline	Between 2010 and June 2020	< 2009
Document type	Journal (research articles/proceeding)	Books, books chapters & Journal (review articles)
Language	English & <i>Bahasa Malaysia</i>	Non-English

2.3.3 Eligibility

Eligibility is the process where the authors manually monitored the retrieved articles by confirming that they are consistent with the study criteria. Before carrying out the eligibility process, a total of four duplicate documents were removed as they have been traced as similar articles. Furthermore, the title and the abstract of the articles were carefully read and the authors excluded two articles due to not put the concentration on debt management and *maqasid Shariah* simultaneously. Overall, only six articles were selected for the reviews.

2.4 Data abstraction and analysis

After going through the eligibility process, the selected articles are subsequently evaluated, reviewed, and analyzed. The results are discussed in detail in this study. The reviews are done based on the studies of the articles that fit the research questions. Then the studies were extracted to identify relevant themes and sub-themes for the present study by the reading of the title, abstract, and then the whole text of the articles. The author conducted integrative reviews - surveys synthesize various types of research designs (qualitative, quantitative methods, and a mixture of quantitative and qualitative). The thematic analysis is considered the most appropriate in synthesizing the integrative reviews (quantitatively and qualitatively) (Flemming et al., 2019). The authors analyzed the remaining six articles in the first stage of theme analysis to extract statements and data that responded to the research questions. The authors then develop groups that give specific meaning through coding techniques in the next phase.

At this phase, the data in the abstract is transformed by the author into useful data and guided by the introduction

of meaningful themes, ideas, or concepts for more relevant data (Patton, 2015). Eventually, this process produced four themes, namely 1) accruing debt, 2) debt behaviour, 3) equity vs. debt, and 4) *maslahah* (benefits) & *mafsadah* (mischief). Through these themes, the same process is done to obtain sub-themes and can produce as many as nine sub-themes. These themes and sub-themes are developed together by all authors through joint discussion and evaluation.

3.0 FINDINGS

From the reviews, four main themes and nine sub-themes being identified based on thematic analysis. The four main themes are accruing debt (two sub-themes), debt behaviour (three sub-themes), equity versus debt (one sub-themes), and *maslahah* (benefits) & *mafsadah* (mischief) (three sub-themes). All of selected articles were thoroughly conducted in Malaysia. A total of three studies used quantitative methods, while two other studies used qualitative methods and one study used mixed method in their studies. In the matter year of publishing, two articles were published in 2011, two in 2013, one in 2016, and one in 2020. (Refer for an explanation of table 3)

Note that in WOS and SCOPUS, only one article was high indexed publication (Q2), three articles were published in the third quartile, and the other were indexed journal. The shortage of high indexed publications in this research topic because not many scholars have published their works in the higher-ranking indexed journal. Based on the evidence, only a few Islamic Scholars contributed to high indexed publications.

Table 3. Table of findings

Authors	Study Design	Accruing debt		Debt behaviour			Equity VS Debt	<i>Maslahah & Mafsadah</i>		
		NC	LV	KW	CS	WF	JE	DR	HJ	TH
Abd Razak & Md Taib (2011)	QT			/		/	/			
Abdul Razak & Ismail (2011)	MM						/			
Khatijah et al. (2013)	QT	/	/	/	/					
Mokhtar & Ismail (2013)	QL							/	/	/
Zainol et al. (2016)	QL	/	/					/	/	/
Amin (2020)	QT			/		/		/	/	/

Accruing Debt	Debt Behaviour	Equity vs Debt	<i>Maslahah</i> (Benefit) & <i>Mafsadah</i> (Mischief)
NC = Necessity	KW = Knowledge	EQ = Justice & equality	DR = <i>Dhoruriyat</i> (Necessity)
LV = Lavish	CS = Coping Skills		HJ = <i>Hajiyat</i> (Complementary)
	WF = Welfare		TH = <i>Tahsiniiyat</i> (Embellishment)

4.0 DISCUSSION

4.1 Accruing debt

No single verse in Al-Quran which prohibits or even condemns the involvement in debt as the creditors or the debtors or even as witnesses. However, Al-Quran does mention how to manage the debt in a proper way (Al-Quran 2:282). In this verse, Islam teaches how debt should be managed since the day it is created between the parties. It includes recorded, validated, and settled when it is due. Moreover, in Islamic teaching, accruing debt is permissible and consider as a serious matter and should not involve in a first-place if it is not crucial and in cases of real necessities (Khatijah et al. 2013), and brings benefit to individuals as well as facilitates to life improvement (Zainol at al. 2016). Under this sub-theme, Islamic perspectives in debt centres on the real necessity of an individual and his domestic usage.

On the contrary, Islam condemns incurring debt for luxury and extravagances that lead to excess and waste (Khatijah et al., 2013) and wealth accumulation (Zainol at al. 2016) because the focal aims of *maqasid al-Shariah* are to protect the family unit and societal well-being. Nonetheless debt may encourage a person to live beyond his means. Thus debt makes a person to work hard to serve his debt and live in financial constraints in order to pay off his debt. Furthermore, the second sub-themes, lavish, is contradict to the objectives of Shariah, which is to protect the wealth of the human being. Incurring debt to fund luxury and extravagance has many negative implications on society, such as debt-ridden, bankruptcy, psychological well-being, health problems, and weak social networks.

4.2 Debt behaviour

Under this theme, this study obtained three sub-themes. First is the knowledge, which will help the people to deal with financing and debt-related facilities for better planning. Fundamentally, Islamic banking consumers are aware of *Shariah*-compliant financial products and able to make a proper assessment of the nature (Abdul Razak & Ismail, 2011). However, a study conducted by Khatijah et al. (2013) found that knowledge among consumers towards debt behaviour is still low compared to debt consumption frequency regardless of educational background, and a better job profession does not imply individuals managing debt. The importance of knowledge applied to the consumer and the bankers because the latter play significant role to bring positive impact to the industry through their effectiveness in conveying messages and promoting Islamic financial transaction and products. Additionally, Amin, (2020) found that the greater the extent of Islamic bankers' knowledge, the better receptiveness of banking products among consumers. Hence, knowledge about financial and debt management is vital to ensure that personal financial sustainability among consumers is intact.

The second sub-theme is coping skills in handling financial stress. It is crucial to control financial stress as it can lead to a miserable life, such as loss of freedom, low in cash flow, loss of time, and loss of opportunities (Khatijah et al., 2013). Coping skills can be improved by increasing knowledge and implying a particular strategy, such as action and planning.

As the third sub-theme, welfare is the main objective of the *maqasid Shariah* which is to promote the welfare of the people lies in safeguarding the faith, life, intellect, posterity, and wealth (Abdul Razak & Md Taib, 2011). When it comes to obtaining financing facilities from Islamic institutions, consumer selection is based on creditworthiness and having collateral. This act is not fit with the essence of *maqasid Shariah* since the bank priority to set aside lower-income groups (Mokhtar & Ismail, 2013). In terms of man behaviour, a man with debt financing (with financing and credit cards) will undergo a challenging situation to fulfilling basic needs since the limited capacity behold him from spending even to other most principal necessities (Khatijah et al., 2013). This situation pointed out that it contradicts the objectives of Islamic law to protect the family unit and well-being.

4.3 Equity versus debt

Islamic law of commercial (*fiqh muamalat*) is fundamentally based on abstaining the Muslim from *riba* (usury) and *gharar* (uncertainty). Pivotal elements in Islamic law is balanced up between moral and material needs of a society to achieve socio-economic justice. Thus it aims to promote equal distribution by upholding a principle of shared risk and rewards in wealth creation through equity rather than debt (Abdul Razak & Md Taib, 2011). Furthermore, Abdul Razak & Md Taib, (2011) discovered in their study that the customers are disappointed with the product offered by Islamic bank that based on *Bai Bithaman Ajil* (BBA), rather than Diminishing Partnership (DP) because it involves high pricing, injustice, and burden to individuals and society. Furthermore, the customer felt that BBA product as a counterpart of conventional products because they claim that money is being traded for money (Abdul Razak & Ismail, 2011). On the contrary, DP promotes profit and risk is shared between the customer and bank, resulting in fairness, justice, and equity (Abdul Razak & Ismail, 2011). Moreover, DP concept does not cause hardship and burden to customers and is aligned with the objectives of *Shariah (maqasid al-Shariah)* (Abdul Razak & Tazwar, 2018).

4.4 *Maslahah* (benefit) & *mafsadah* (mischief)

The concept of *maslahah* represents an approach in Islamic jurisprudence to harmonize between revelation and real situations, which is the reason the law was set up to satisfy for the benefit human well-being (Omar & Sari, 2019). The first sub-theme under this *maslahah* and *mafsadah* is *dhoruriyat* (basic need/necessity). Necessity is defined as the element that human life would be imperfect if these aspects were neglected, such as religion, life intellect, lineage, and property. The welfare of individuals and society depends on the preservation of these elements (Zainol et al., 2016). The recent study by Amin (2020) shows that the role of *maqasid Shariah* in shaping consumers' receptiveness of Islamic home financing is significant since the purchasing of houses as a basic need. The study intends to examine customer's belief in Islamic bank whether it follows *maqasid al-Shariah* when offering the facility to the public or otherwise.

The second sub-theme is *hajiyyat* (complementary) benefits which refers to things needed by humans to provide comfort and harmony in life. The absence of *hajiyyat* will not cause big trouble if the main necessity has been fulfilled because it focuses on restoring and improving human life (Zainol et al., 2016).

Meanwhile, the last sub-theme is *tahsiniyyat* (embellishment) is a situation that brings the improvement in life and attainment something desirable or even attaining luxurious (Mokhtar & Ismail, 2013). In a nutshell, Islam permits debt as it creates many benefits to individuals as well as facilitates their needs as long as they follow the rule of

taking debt according to the specific situation. On top of that, acquiring debt for complementary benefit and embellishment is permissible but it is strongly not encouraged. The guideline, as required by Islam, is to look at the capability of the individual to perform instalment and control the desires of the individual by prioritising the needs (Zainol et al., 2016).

5.0 FUTURE DIRECTION

There are remains unknown and scarcity of discussion and understanding of debt management in perspectives of *maqasid Shariah*. Several research areas need to be given attention since it can lead to significant potential to study. In connection with the research method, both quantitative and qualitative approaches are balanced. However, relying on the specific kind of research, either availability, feasibility, awareness, and exploration, the qualitative method should be used vastly. The nature of qualitative studies seek detailed explanations and focus on in-depth responses obtained from the participants.

In the review, the majority of the studies on *maqasid Shariah* in debt management are conducted in Malaysia. Only few studies were performed in other countries. A comparison of the countries can contribute to the body of knowledge. Moreover, the future research should include additional databases to enrich searching for more articles such as Google Scholar, Era Journal List, My Cite and etc.

Other gaps in the research areas that can be performed include topics in the themes of accruing debt, debt behaviour and *maslahah/mafsadah*. It is fundamental to document each finding in a scholarly and meaningful way because this will assist future scholars in understanding the real conditions of debt in society. Based on the themes from previous literature, the available existing studies still are lacking to offer a clear explanation of how the adaptation of *maqasid Shariah* in debt management among individuals. Hence, future research should consider this gap. On the other hand, prospective scholars should explore new investigation towards knowledge and literacy of debt management among individuals.

6.0 CONCLUSION

The primary purpose of this study is to systematically review the adaptation of *maqasid Shariah* in debt management among Muslims. The study offers several improvements and contributions for practical purposes and the body of knowledge. From the review, the interest parties, especially the policymaker, financial institutions, public, and researcher, can comprehend the short and long term of debt management. The result offers some basic on how Islam views debt and what are the guidelines given all this while. Furthermore, the results can assist the researchers on the specific area and content of studies related to *maqasid Shariah* in debt management that should be the focus of their studies. The review concludes that accruing debt is permissible from the perspective of *maqasid Shariah* but only in real necessity and does not involve in luxury and extravagance financing. The Muslim who needs to accrue debt should limit it within his own capacity and should know the priority.

REFERENCES

- Al-Quran.
- Abdul Razak, D., & Ismail, Y. (2011). Diminishing Partnership: Bankers Strategic Response to Shariah Compliant Home Financing. *IJUM Journal of Economics and Management*, 19(3), 177–196.
- Abdul Razak, D., & Md Taib, F. (2011). Consumers' perception on Islamic home financing. *Journal of Islamic Marketing*, 2(2), 165–176. <https://doi.org/10.1108/17590831111139875>
- Abdul Razak, D., & Tazwar, F. (2018). Islamic Home Financing Practices In Selected Oic Countries: An Assessment In The Light Of Maqasid Al-Shariah. 3(2), 54–67. Retrieved from <http://repositorio.unan.edu.ni/2986/1/5624.pdf>
- Ali, N. A., Wan Ahmad, W. M., Sarif, S., Kamri, N., 'Azzah, & Azahari, R. (2018). Application of the Concept of Maslahah in Household Debt Management. In *New Developments in Islamic Economics* (pp. 19–33). Emerald Publishing Limited. <https://doi.org/10.1108/978-1-78756-283-720181002>
- Amin, H. (2020). Critical success factors for the receptiveness of Islamic home financing in Malaysia. *International Journal of Emerging Markets*, 15(5), 849–873. <https://doi.org/10.1108/IJOEM-04-2018-0187>
- Azhar, A., Hussain, M. A., Md. Nor, M. Z., & Othman, M. K. (2017). Penyelidikan Fatwa Dalam Kerangka Maqasid Al-Syariah : Satu Tinjauan. *Ulum Islamiyyah*, 20(January 2016), 47–65.
- Azma, N., Rahman, M., Adeyemi, A. A., & Rahman, M. K. (2019). Propensity toward indebtedness: evidence from Malaysia. *Review of Behavioral Finance*, 11(2), 188–200. <https://doi.org/10.1108/RBF-05-2017-0046>
- Buang, A. H. (2009). Pengurusan harta keluarga mengikut Islam dan realiti semasa di Malaysia. *Jurnal Muamalat*, 2, 1–15.
- Flemming, K., Booth, A., Garside, R., Tunçalp, Ö., & Noyes, J. (2019). Qualitative evidence synthesis for complex interventions and guideline development: clarification of the purpose, designs and relevant methods. *BMJ Global Health*, 4(Suppl 1), e000882. <https://doi.org/10.1136/bmjgh-2018-000882>
- Khatijah, O., Sapura, S., Zulkiple, A. G., & Jusoff, K. (2013). Debt ridden behaviour and coping skill from an islamic spectrum. *Middle East Journal of Scientific Research*, 13(SPLISSUE), 35–41. <https://doi.org/10.5829/idosi.mejsr.2013.13.1879>
- Martín-Martín, A., Orduna-Malea, E., Thelwall, M., & Delgado López-Cózar, E. (2018). Google Scholar, Web of Science, and Scopus: A systematic comparison of citations in 252 subject categories. *Journal of Informetrics*, 12(4), 1160–1177. <https://doi.org/10.1016/j.joi.2018.09.002>
- Mohamed Shaffril, H. A., Ahmad, N., Samsuddin, S. F., Samah, A. A., & Hamdan, M. E. (2020). Systematic literature review on adaptation towards climate change impacts among indigenous people in the Asia Pacific regions. *Journal of Cleaner Production*, 258, 120595. <https://doi.org/10.1016/j.jclepro.2020.120595>
- Mohamed Shaffril, H. A., Samah, A. A., Samsuddin, S. F., & Ali, Z. (2019). Mirror-mirror on the wall, what climate change adaptation strategies are practiced by the Asian's fishermen of all? *Journal of Cleaner Production*, 232, 104–117. <https://doi.org/10.1016/j.jclepro.2019.05.262>
- Mohd Al-Bakri, Z. IRSYAD AL-FATWA KE-62: SYARAT-SYARAT PERLAKSANAAN DARURAT, Pejabat Mufti Wilayah Persekutuan § (2015). Kuala Lumpur: Pejabat Mufti Wilaya Persekutuan. Retrieved from <https://muftiwp.gov.my/ms/artikel/irsyad-fatwa/irsyad-fatwa-umum/1904-irsyad-fatwa-ke-62-syarat-syarat-perlaksanaan-darurat>
- Mokhtar, M., & Ismail, A. (2013). Shariah issues in managing household debt: The case of Malaysia. *Jurnal Pengurusan*, 37, 63–76.
- Okoli, C. (2015). A guide to conducting a standalone systematic literature review. *Communications of the Association for Information Systems*, 37(1), 879–910. <https://doi.org/10.17705/1cais.03743>
- Omar, M. N., & Sari, N. M. (2019). MAQASID AL-SHARIAH PHILOSOPHY IN MONETARY REGIME TOWARDS INCLUSIVE SUSTAINABLE GROWTH. *International Journal of Islamic Economics*, 1(02), 95. <https://doi.org/10.32332/ijie.v1i02.1802>
- Patton, M. Q. (2015). *Qualitative Research & Evaluation Methods* (4th ed.). SAGE Publications Inc.
- Rahman, M., Azma, N., Masud, M. A. K., & Ismail, Y. (2020). Determinants of Indebtedness: Influence of Behavioral and Demographic Factors. *International Journal of Financial Studies*, 8(1), 8. <https://doi.org/10.3390/ijfs8010008>
- Samsuddin, S. F., Shaffril, H. A. M., & Fauzi, A. (2020). Heigh-ho, heigh-ho, to the rural libraries we go! - a systematic literature review. *Library and Information Science Research*, 42(1), 100997. <https://doi.org/10.1016/j.lisr.2019.100997>
- Shinkafi, A. A., & Ali, N. A. (2017). Contemporary Islamic economic studies on Maqasid Shari'ah : a systematic literature review. *Humanomics*, 33(3), 315–334. <https://doi.org/10.1108/H-03-2017-0041>
- Toto Ngadiman, D. W., Rahim, H. A., Yacoob, S. E., & Wahid, H. (2019). Harga Diri, Niat Menambah Pinjaman Dan Gelagat Perbelanjaan Individu Muslim Berpendapatan Rendah Di Sektor Perladangan. *UMRAN - International Journal of Islamic and Civilizational Studies*, 6(1), 49–61. <https://doi.org/10.11113/umran2019.6n1.276>
- Wong, G., Greenhalgh, T., Westthorp, G., Buckingham, J., & Pawson, R. (2013). RAMESES publication standards: meta-narrative reviews. *Journal of Advanced Nursing*, 69(5), 987–1004. <https://doi.org/10.1111/jan.12092>
- Yusoff, M. B., Hasan, F. A., & Jalil, S. A. (2000). Globalisation, economic policy, and equity : The case of Malaysia. In *OECD Development Center* (p. 18). Retrieved from <http://www.oecd.org/dataoecd/54/49/2682426.pdf>
- Zainol, Z., Nizam, A. N. H. K., & Ab Rashid, R. (2016). Exploring the concept of debt from the perspective of the objectives of the Shariah. *International Journal of Economics and Financial Issues*, 6(7Special Issue), 304–312.
- Zamri Zainal Abidin, Rosli Mokhtar, & Fakhri Sungit. (2016). Maqasid As-Syariah Dalam Indeks Syariah Malaysia. *Muzakarah Fiqh & Internasional Fiqh Conference*, 22(November), 221–236. Retrieved from <http://conference.kuis.edu.my/mfifc/eprosiding/221-236-mfifc-2016.pdf>

THE ISLAMIC BUSINESS ETHICS IN E-COMMERCE: EVIDENCE FROM MALAYSIAN HALAL E-MARKETPLACE

Mariana Jusop^{*a}, Risyawati Mohamed Ismail^b, Noor Azizi Ismail^c

^aUniversiti Sultan Zainal Abidin, Malaysia

^bUniversiti Utara Malaysia, Malaysia

^cUniversiti Malaysia Kelantan, Malaysia

Abstract

This study evaluates the Islamic business ethics practices in a halal e-commerce marketplace in Malaysia. The study focuses on the quality management aspects of e-commerce and how the Islamic business ethics are practiced in the platform. Although there have been numerous studies in this discourse, the area remains to experience range of grasps in halal e-commerce context. Halal e-commerce is unique as it is based on Islamic teachings hence different from other information systems researches. This study shifts the focus from conventional e-commerce setting where quality and ethics are commonly studied, to gain insights into these differing understandings from halal e-commerce marketplace operators as they engaged in Sharia-compliant platform. The preliminary case study was carried out with a small-sized halal e-commerce marketplace in Malaysia. Evidently, the qualitative findings present meaningful ethical practices as regarded by halal e-commerce marketplace. Though, future research needs to include and investigate more cases in which other contextual factors were taken into consideration for a wholesome approach in understanding a halal e-commerce success as guided by Sharia.

Keywords: halal e-commerce, preliminary study, interview, business ethics

1.0 INTRODUCTION

Trade and commerce have always been a part of Islam. Prophet Muhammad (p.b.u.h) was himself engaged in this profession before he became a prophet. Known for his integrity and trustworthy, he was a very successful businessman at that time. Even after the advent of Islam, the tendency of the Arab community towards business was not hindered by the religion, in fact the Qur'an gave a strong encouragement to its people to get involved in business. In addition, the Quran includes rules not only for manners and hygiene, marriage and divorce, but it also lays down detailed rules for commerce and politics, interest and debts, contracts and wills, and industry and finance. That's mean, venturing into business requires Muslim to follow the rules and guidelines set by Islamic law.

The objectives of Islamic principles or laws in business is based on benefiting the humanity while maintaining Allah's orders. In business, Islam strictly forbids any discrimination between people regardless of their religion, sex, or gender. There is no conflict between good business practice and profit making in Islam. Islam accords the importance of the trading sector as source of wealth and the roles its play to the development of the country and the ummah as a whole (*maslaha ummah*). Therefore, Islam primarily reposes the impact of trading brought to *maslaha* and looks at profit as secondary way to measure efficiency. In this regard, the holy Quran abounds with many references to the trade and commercial activities, one of the mis "*And O my people, Give full measure and weight in justice and reduce not the things that are due to the people, and do not commit mischief in the land, causing corruption*" (Hud, part 12, verse,85.). This verse warns Muslims not to cheat in business and asks to behave ethically in whatever they do in daily life.

The businessmen always face various ethical issues which are sometimes difficult to solve. Bribery, theft, fraud, conflict of interest, quality control issues, misrepresentation, environmental pollution and abuse of public funds are among ethical issues confronted by many businessmen. Likewise, e-commerce in halal industry is also facing more stringent issues due to recent food scandals, fake halal logo and certification, concerns of privacy and information security, and various online frauds (e.g. Khalid, Ashrof, & Yaakob, 2016; Othman, Shaarani, & Bahrn, 2016; Shafii & Zain, 2015). Also, there are some integrity issues such as the business no longer adopt the quality standard after obtaining halal certification (Sawari, et al. 2015) and insecurity in online payment method (Sulaiman, et al. 2017) are still currently reported by mass media.

Considering this fact, any decisions that need to be made by a Muslim businessman should be made based on *iman* or faith. Albeit hundreds of researches have been written on Islamic business ethics, only a few empirically discuss it in the context of halal e-commerce. Thus, it is the main objective of this study to explore how the Malaysian halal marketplace bring about these ethical issues in managing their e-commerce platforms so that it conforms to Sharia requirements.

2.0 LITERATURE REVIEW

2.1 Halal E-Commerce Marketplace

As the Internet evolved and matured, many businesses have taken advantage to incorporate it into their business models and use it to conduct most of their business activities. The technology has paved the way for businesses to make use of e-commerce websites as alternative sales channels due to increasing trends of online shopping. Trading over the Internet is usually referred to as 'electronic commerce' (e-commerce). It involves the use of the Internet for buying and selling activities such as advertising, negotiations, and contracts (Simpson and Docherty, 2004). In the context of this research, 'halal e-commerce' is used in its broadest sense where it includes the process of buying, selling, transferring products or services and information via the internet in accordance with Islamic business practice and Sharia requirements (Jusop, Ismail and Ismail, 2018). In other words, the requirements to conduct online business through halal platform must at least devoid of *riba'* (usury or interest), *gharar* (uncertainty), haram (unlawful) and *maysir* (gambling) elements (Ribadu & WanAbRahman, 2016; Amboala et al. 2015; Muhammad et al., 2013, Badawi, 2001).

Apparently, more organizations are aware that venturing into halal business require certain compliance to quality standards and regulations, as well as Sharia requirements (Marzuki, Hall and Ballantine, 2012). This is evidenced with the increase in the number of organizations applied and received halal certification (3,328 companies in 2010 and 6,133 companies in 2018 are halal certified) as data showed by Halal Statistics Malaysia (Department of Statistics Malaysia, 2016; Jakim, 2018) and encouraging participation in halal trade exhibitions every year. The Department of Standards Malaysia and Department of Islamic Development Malaysia (JAKIM) play a big role by providing credible standards and accreditation to help halal businesses improve quality, productivity and efficiencies for greater marketability of their products and services. Malaysia's halal standard has strong and comprehensive guidelines within the scope of Islamic laws that helps the authorities monitor the preparation and handling of halal products. However, there are still a number of weaknesses in regard to the halal quality assurance that is still being reported in media. There are businesses that breach quality standard after obtaining halal certification (Sawari, et al., 2015). Therefore, it is important to explore how the halal marketplace bring about the quality aspects of the e-commerce platform and abide to ethical standards so that the trading activities conform to Sharia requirements.

E-marketplace is a virtual market that gathers many buyers and suppliers meet to exchange information about product and service offerings, and to negotiate and execute business transactions. Even though e-commerce has been around in Malaysia since the mid-nineties, the halal e-marketplace ecosystem has just seen a massive growth in the region started 2007 and 2016 with the establishment of Daganghalal, Zilzar and Aladdin street. In the effort to boost the country's e-commerce GDP contribution, the government designed the National eCommerce Strategic Roadmap (NeSR) in 2016 and launched the Digital Free Trade Zone (DFTZ) at the end of 2017. According to The Malaysia External Trade Development Corporation (MATRADE), although late to e-commerce the halal platforms are one of the avenues to grow the country's international trade as they are more cost-efficient and have a greater outreach as compared to offline brick-and-mortar channels. Besides going digital on their own, businesses can make their existence a greater visibility to potential customers by listing products or services on e-commerce platforms or marketplaces. Usually, these online shopping marketplaces gather various brands and types of products from different manufacturers and have always been the customers' focus for a faster product selection. With the emergence of halal e-commerce marketplaces, both consumers and suppliers can 'conveniently meet' through this platform for a business deal. This is the place where consumers can find halal products or services and for suppliers to cater the halal niche market. Thus, the halal e-commerce marketplace is not only as an alternative but a complement to other conventional platforms that exist nowadays.

2.2 The Islamic Business Ethics

Ethics refers to a set of rules and principles that guided people's choice of what is right or wrong (Ismail, Ullah, & Zaheer, 2019). It plays a significant role in the social and economic development of a nation. In business, ethics are important to maintain customers' trust and improves business reputation. Around the globe, hundreds of researchers argued that religion and philosophy set the great influence on the business ethical practices of a

country. For example, Cui and Jo (2019) and Bernacchio (2019) believed that Christian is a religion that has influenced corporate ethical behaviour in conventional business organizations. While, other studies opined that among the fundamental philosophy of business ethic theories is based on Utilitarianism (Samara & Paul, 2019), Libertarianism (Block, 2019), Perfectionism (Nunziato & Hill, 2019), and Deontology (Mea & Sims, 2019). They viewed that these philosophical foundations inspired the contemporary business ethics practices. However, the foundation of Islamic business ethics is basically grounded on Sharia principles (San-Jose & Cuesta, 2019). In Islamic theology and philosophy, *akhlak* is generally used to refer to a noble character, morality and ethical conduct. Among others, integrity and trustworthy are the characters of a good businessman as displayed by Prophet Muhammad (p.b.u.h) (Ismail, Ullah, & Zaheer, 2019).

In Islamic economy, a success can be achieved when the fundamental objective of Sharia, known as *maqashid sharia*, is realized. The *maqashid sharia* includes the protection of five elements of life, namely the care of religion, soul, intellect, lineage and wealth. The adequate combination of these five elements will bring a good impact called *maslahah* (Jauhar, 2009). The focus of this paper is to discuss the trading activities, as one of the most important activities in the wealth accumulation events. In the realm of *maqashid sharia* and accomplishment of *maslahah* when trading, then the trade must be in accordance with the rules in Islam. The Prophet (p.b.u.h) said "*Honest and trustworthy traders will be resurrected with the Prophets, the shiddiq people and the martyrs*" (Hadith by Tirmidzi).

The above hadith showed a noble position of an honest trader or businessman that he will be resurrected with the Prophets, the believers and the martyr. The honest and trustworthy traders, of course, do not cheat their consumers and this will provide benefits (*maslahah*) for all trading parties. Even though trading is the main source of wealth, it is not only about money and profit, but more about strengthening the branding image, ensuring the continuity of business and forming the good relationship among all parties involved (Boediman, 2017).

Along with the current development of technology, all trading activities are based on fulfilment and facilitating consumers' needs. Over 1.8 billion Muslims around the world concern to only patronize Sharia-compliant goods and services (Ribadu & Rahman, 2017). Thus, in e-commerce transactions, halal businesses are challenged to strictly follow the Islamic principles of conducting online business. It requires them to understand the process of carrying out business electronically and combine it with Islamic ethics in order for the system to success (Jusop, et al., 2018). Although the way of doing business are constantly changing over period of decades, but the principles for the betterment of human being must not be changed and must be applied as the basic foundation for all business activities.

For this purpose, Islam has provided a comprehensive list of ethics as a guidance on how business should be conducted, accounting to be undertaken, and banking/finance is to be arranged (Lewis, 2001). In view of this aspect, Islamic business ethics requires Muslims to be fair, honest, accountable and equitable toward others. While Kolan et al. (2018) summarized the Islamic business ethical codes such as commitment, transparency, truthfulness, and reliability as a guideline for running a successful business. It involves the willingness to give full commitment to fulfil the contractual promises, providing transparent information, and avoiding misrepresentation in business dealings. Moreover, it is important to bear in mind that the practices and principles of business ethics should be guided by the Quran and hadith as the key teachings of Islam. The businessman should really understand about business concepts and ethical codes of conducts in order to be successful in online commerce.

3.0 METHODOLOGY

This study used in-depth, semi-structured interviews as a primary data collection. The informants were identified through a web search when the researcher was looking for halal e-commerce websites to become a case study. An e-mail was sent asking if the organization is willing to participate in the research study. Upon receiving their agreement, a formal letter was sent to the organization's representative personnel and an appointment was made to interview the informants. Together with the letter, the background of the study, research objectives and pre-determined interview questions were also given to the informants so that they could get the overview of the research study. Prior to the interview, the researcher studied the website of the company to understand its business, range of products and services offered.

Two informants were interviewed and permission was obtained to audiotape the interview using IC recorder. The study seeks to get insights from marketplace operators as how they managed the platform in compliant to Islamic law. The elected informants are those in decision making position and upper manager who's directly involved in the operation of the platform. In this preliminary study, the first informant is the Chief Executive Officer (CEO) of the company. The interview with the CEO lasted approximately 1 hour and 20 minutes. The second interview

with Marketing and Sales Executive (MSE) takes about 55 minutes. From here, researcher learned that the interview session should be controlled wisely to ensure the time-outcome efficient for both parties. The interviews were carried out in Malay language with occasional use of English, as it was perceived as more casual and comfortable for both interviewer and interviewees. The interviewer did not ask the questions in orderly form but rather follow the flow of the conversation. The interviewees were given a flexibility to freely discuss around each question.

The interviews were transcribed and analysed using three-step strategies as proposed by Creswell (2014). First, the transcriptions were read several times to obtain a general review of all information. In this process, the important notes were jotting down and key phrases were highlighted from the text to reflect the initial coding. Second, the data were reduced by developing codes and then the codes were sorted into similar themes or categories. The process of coding was carried out and completed in several iterations. Lastly, the frequency of codes was counted to determine how frequently each codes appear in the database. The evidence from the data analysis is presented in relation to research objective and discussed in the scope of IS success model and Sharia requirements.

4.0 RESULTS AND DISCUSSION

4.1 The Case

As a preliminary study, the researcher investigated a medium-sized e-commerce marketplace that offer all halal products in their platform (Company X). Set up in 2017, the company regards itself in its infancy stage and do not generate much income from the e-commerce transaction. Fortunately, the company has a strong team or business unit to support its operation. This is mentioned by the CEO, *“in order to sustain every month, we need to have something else to support. In this company...we sustain through providing service such as halal testing, training, and consultation. So for now, these things cover whatever our costs...”*. Company X has a JAKIM's recognised lab that offers testing and verification services covering the scope of halal, *toyyiban* and ethical testing. Besides targeting SMEs as niche market, it assists them to get halal certification through product testing, consultation and training. The company is also actively joined offline programs, road tours and exhibitions in order to expose its existence in halal marketplace.

However, some limitations faced by Company X such as the challenge to convince suppliers to put their products in this platform. As a result, the company currently only have 120 stock keeping units (SKUs) from three suppliers. The limited range of products offered by the platform makes consumers less attracted, thus lead to slow web traffic and low income generated by the online transactions. Based on current situation, the CEO said the company is not ready to embark into the international market because of products and financial constraints. Despite these challenges, the company is optimistic that well-organized qualitative criteria of e-commerce could help to improve towards the betterment of the halal e-commerce platform. These also includes to observe ethical aspects and Sharia requirements while managing the platform.

4.2 The Quality Management of Halal E-Commerce Platform

Company X sets out certain information requirement for its suppliers to be included in the website. Apart from company name, contact info and halal certificates, the suppliers are required to provide details such as products description, ingredients, usage method, expiry date, nutritional facts, price and pictures. The CEO delegates the responsibility to verify that information to her MSE upon receiving the information from suppliers. The MSE will make sure the information is complete before it is uploaded to the website. She refers to JAKIM to verify the halal status of the suppliers and check relevant standards as the bases or guidelines for completing the tasks.

In order to enhance customers' trust, Company X disclose all the information that can help customers make decision before purchasing the products. Besides information about the products itself, all terms and conditions related to the purchase such as payment and delivery method are clearly stated. Same goes to the arrangements with suppliers, the company has transparently mentioned in their agreement if there are any charges or terms to be included. Usually, the CEO will meet prospective suppliers face-to-face to discuss the listing fee, products' price, amounts and types of SKU to be sold. The proper management of information in online commerce is important so that suppliers, sellers, and buyers are clear about the transactions being conducted and avoiding any disputes.

The website design and e-commerce platform for Company X is outsourced from a local web developer. The system is designed to be compatible with the use of current social media networks including Facebook, Instagram

and WhatsApp. These applications could create greater sales and act as effective sharing ecosystem among customers and sellers. Since the number of mobile users are getting high, Company X is planning to launch its own mobile app in order to connect and build deeper relationship with its loyal customers. This is to provide variability and alternative choice for users instead of using website. But costs would be the main limitation for the company to implement this plan promptly.

The CEO alleged that it is the responsibility of halal e-commerce organizations to give confidence and certainty to consumers for using halal platforms. The participants viewed the promise to deliver halal products and transactions as their commitment to gain customers' trust. They emphasized that logistic is one of the most critical issue faced by halal e-commerce businesses specially halal food producers. The CEO said, "*our biggest limitation to go abroad is because we don't have our own logistics. It is very expensive to post a single item to overseas*". Her statement was supported by the MSE who mentioned that a customer service function can be improved by having a logistics system that they can control or monitor. This organization claimed that they can make sure the quality and halal status of materials used and the processes undergone to complete the products, but when it is the time to deliver the goods, halal logistic was very limited and the costs were normally high.

4.3 The Business Ethics

Running an online business require a bunch of ethical issues to consider. Online data security, accurate product listing, no counterfeit products, web accessibility, and observing online selling laws were just a few examples of e-commerce best practice. However, for a halal e-commerce business, the ethical practices go beyond normal expectation. For instance, selling halal products without halal certification is alright, but that way will not enhance customers' trust. Likewise, charging excessive amount over a product's price might not impact certain customers, but it is clearly violating business ethics.

Company X provides consultation to suppliers and assist them to get halal certification from JAKIM. While waiting the certification to be approved, the company help the suppliers to enter halal marketplace by providing a seal that testify the products are free from porcine or alcohol elements after testing it in their lab. Ethics, as revealed by Company X, are frequently violated by manufacturers who think of profits as the sole objective of business. These manufacturers gave halal sample to be tested prior obtaining halal certificate, but will use different types of ingredients in actual production. "*I hope JAKIM will put halal testing (in lab) as a compulsory audit procedure*", proposed the CEO to overcome the problem.

Added to her argument, the CEO said that a halal e-marketplace should list only halal products in the platform and do not mix any unlawful items in the SKUs. This is important to enhance consumers' trust. Moreover, the determination to provide payment alternatives that are free from *riba* and trusted delivery method indicates their commitment towards ethical or Sharia compliant practice. "*The combination of halal product, halal payment, halal logistic, only then we can create halal community*" she said. The use of cash on delivery, debit card and e-wallet can eliminate *riba* in payment. Whereas the delivery of products through halal logistic mediums shows the responsibility of halal e-commerce providers to uphold Islamic ethics in trading.

While the CEO expressed her apprehension to ethical issues, her assistant, the marketing executive added to the point of monitoring roles by halal authority. She said frequent audit and constant training should be enhanced in order to enforce the ethics and integrity values in halal e-commerce practices. This is because, in addition to enforcement, businessmen should be educated and reminded of the importance of ethics in business. Enduring in ethical values does not cause losses to business, but the Sharia-compliant business practice has positive effects on long-term financial performance. As proposed by Pepis & De Jong (2018), this practice produces long-term benefits for the firm by increased values in return on assets (ROA) and return on sales (ROS) of the business.

5.0 CONCLUSION

The Muslimeconomy is growing based on a spirit of cooperation and mutual help in the life of society. In Qur'an, there are many verses that clearly shows the encouragement to the believers to engage in business. Allah s.w.t states that the way to get property or wealth is through business which is done honestly and trustworthily. Through this adherence, both parties will be satisfied with the goods that have been sold and benefit all parties involved in the business. Islam has outlined several things that a business should follow to success. Among them are to avoid treacherous acts, trading illegal things, being arrogant, selling non-existent goods or scams, and swearing lies to convince buyers. Therefore, a businessman should know and understand the ethics of Islamic business in depth before getting involved in business so that he can form personal purity and subsequently achieve excellence in life in the world and hereafter.

REFERENCES

- Adam, Z. R., (2016, April 7). New halal e-commerce site Aladdinstreet aiming for \$750 million in revenue for first year of operations. *Salaamgateway*, Retrieved from <https://www.salaamgateway.com>
- Amboala, T., Mokhtar, A. H. A., Muhammad, M. Z., Noordin, M. F. bin, & Othman, R. (2015). Development Method for Shariah Compliant e-Commerce Payment Processing. *International Journal of Computer Theory and Engineering*, 7(5), 408–415. <http://doi.org/10.7763/IJCTE.2015.V7.995>
- Badawi, J. A. (2001). Islamic Business Ethics. *Spiritual Goods: Faith Traditions and the Practice of Business*, (October), 295–323. <http://doi.org/10.5840/spiritgds200127>
- Bernacchio, C. (2019). Pope Francis on conscience, gradualness, and discernment: Adapting Amoris Laetitia for business ethics. *Business Ethics Quarterly*, 29(4), 437-460.
- Boediman, E. P. (2017). Halal Life Style in Marketing Communication and E-Commerce. *International Journal of Pure and Applied Mathematics*, 117(15), 931-944.
- Creswell, J. W. (2014). *RESEARCH DESIGN Qualitative, Quantitative, and Mixed Methods Approaches*.
- Economy (2017, July 26). Mustapa: DFTZ, NESR to boost e-commerce contribution to GDP. *The Star Online*, Retrieved from <http://www.thestar.com.my/business/business-news/2017/07/26/dfz-and-nesr-to-boost-e-commerce-contribution-to-gdp/#TgGq5Q4MDCaMibhe.99>.
- Ismail, M., Ullah, S., & Zaheer, Z. (2020). Assessing Islamic Business Ethical Practices Through Clients' Perception. *NICE Research Journal*, 92-108.
- Jusop, M., Ismail, R. M., & Ismail, N. A. (2018). Understanding Halal E-Commerce Practice: A Proposed Conceptual Framework. *Global Business & Management Research*, 10(3).
- Khalid, M. M., Yaakob, M. A. Z., Sirajuddin, M. D. M., Bhari, A., & Mahfot, M. (2016). Risk analysis in the halal food industry: an exploratory study. In *Contemporary Issues and Development in the Global Halal Industry* (pp. 67-79). Springer, Singapore.
- Kolan, N. F., Jailani, N., Abu Bakar, M., & Latih, R. (2018). Trust model based on Islamic business ethics and social network analysis. *International Journal on Advanced Science, Engineering and Information Technology*, 8(6), 2323-2331.
- Lewis, M. K. (2001, June). Islam and accounting. In *Accounting forum* (Vol. 25, No. 2, pp. 103-127). Blackwell Publishers Ltd.
- Marzuki, S. Z. S., Hall, C. M., & Ballantine, P. W. (2012). Restaurant managers' perspectives on halal certification. *Journal of Islamic Marketing*.
- Mea, W. J., & Sims, R. R. (2019). Human dignity-centered business ethics: A conceptual framework for business leaders. *Journal of Business Ethics*, 160(1), 53-69.
- Muhammad, M., Muhammad, M. R., & Khalil, K. M. (2013). Towards Shari' ah Compliant E-Commerce Transactions : A Review of Amazon . com. *Middle-East Journal of Scientific Research*, 15(9), 1229–1236. <http://doi.org/10.5829/idosi.mejsr.2013.15.9.11176>
- Nunziato, J. S., & Hill, R. P. (2019). Perfectionism and the Place of the Interior Life in Business: Toward an Ethics of Personal Growth. *Business Ethics Quarterly*, 29(2), 241-268.
- Othman, B., Shaarani, S. M., & Bahron, A. (2016). Evaluation of knowledge, halal quality assurance practices and commitment among food industries in Malaysia. *British Food Journal*.
- Reuters, T. (2015). State of the GLOBAL ISLAMIC ECONOMY. *Dubai the Capital of Islamic Economy*, 1–287. <http://doi.org/10.1017/CBO9781107415324.004>
- Ribadu, M. B., & Rahman, W. N. W. A. (2016). A generic framework for e-commerce requirements to comply with Sharia in business-to-consumer perspective. *Proceedings of 2016 SAI Computing Conference, SAI 2016*, 752–757. <http://doi.org/10.1109/SAI.2016.7556064>
- Ribadu, M. B., & Wan Ab. Rahman, W. N. (2017a). An integrated approach towards Sharia compliance E-commerce trust. *Applied Computing and Informatics*. <http://doi.org/10.1016/j.aci.2017.09.002>
- Ribadu, M. B., & Wan Ab. Rahman, W. N. (2017b). Sharia Compliance Service Quality Metrics for E- Commerce: an Exploratory Analysis. *ICOCI Kuala Lumpur. Universiti Utara Malaysia*, (147), 25–27. Retrieved from http://icoci.cms.net.my/PROCEEDINGS/2017/Pdf_Version_Chap06e/PID147-332-340e.pdf
- Samara, G., & Paul, K. (2019). Justice versus fairness in the family business workplace: A socioemotional wealth approach. *Business Ethics: A European Review*, 28(2), 175-184.
- San-Jose, L., & Cuesta, J. (2019). Are Islamic banks different? The application of the radical affinity index. *International Journal of Islamic and Middle Eastern Finance and Management*.
- Sawari, S. S. M., Ghazali, M. A. I., Yap, S. M. A. B., & Latif, A. A. (2015). E-Halal as Method and Apparatus for Halal Product Detection in Malaysia. *Mediterranean Journal of Social Sciences*, 6(5), 638.
- Shaffi, Z., & Zain, S. N. (2015, February). Halal assurance mechanisms in Halal industry: An appraisal on its effectiveness towards continuous Halal assurance and the way forward. In *2nd International Conference of Education and Social Sciences (INTCESS15)* (pp. 430-38).
- Simpson, M., & Docherty, A. J. (2004). E-commerce adoption support and advice for UK SMEs. *Journal of Small Business and Enterprise Development*, 11(3), 315–328. <http://doi.org/10.1108/14626000410551573>
- Sulaiman, H., & Abdullah Maamuom, M. (2017). Determinants of Success for ERP Data Governance Implementation in a Malaysian Utility Organization. *Indian Journal of Science and Technology*, 10(48), 1–10. <http://doi.org/10.17485/ijst/2017/v10i48/120777>

ISLAMIC PERSPECTIVE OF THE MALAYSIAN OCCUPATIONAL SAFETY AND HEALTH (OSH) LEGISLATION

Sharija Che Shaari^a, Nik Ahmad Kamal bin Nik Mahmud^b, Farheen Baig Binti Sardar
Baig^c

^a Senior Lecturer (Law), Faculty of Business, Economics and Accountancy, Universiti Malaysia Sabah, Kota Kinabalu, Sabah

^b Professor, Department of Civil Law, AIKOL, International Islamic University Malaysia, Kuala Lumpur, Malaysia

^c Associate Professor, Department of Civil Law, AIKOL, International Islamic University Malaysia, Kuala Lumpur, Malaysia

Abstract

This study attempts to discuss the occupational safety and health legislation from the Islamic perspective. Islam is a comprehensive religion (syumul) thus it covers a practical system of life, and it guides all aspects of life be it from an individual perspective or community. Hence, it is the objective of this study to explore the congruency between Islamic principles and existing OSH legislation. Islam has its view about work and has placed great importance on work. A healthy employer-employee relationship is crucial for some mutual benefits for both sides. Islamic teachings aim to allow people to earn their living fairly and profitably without the exploitation of others, so that the whole society may benefit. Thus Islamic teachings strictly forbid an employer from overburdening his employees; prohibit an employer from allocating dangerous and degrading work to his employees. Islamic principles promote consultation (Shura) which means an employer is encouraged to consult and obtain consensus from the employees before establishing rules and regulations at a workplace. Such provisions are embedded in the existing OSH legislation. Similarly, the concept of Shura is akin to the establishment of the safety committee at a workplace. A holistic system that can be found in Islamic teachings aims at contributing to the fulfilment of the social-economic objectives and creation of just society, which will bring lasting balance between employers and employees to achieve betterment for the whole community. Hence, an employer strives to perform his duties accordingly, and such action is reciprocated by the employee, the proper relationship between both parties will be enhanced which will eventually lead to a better environment at any workplace. This study is essential in understanding how Islam provides a complete and comprehensive way of life leading to a balanced way of living.

Keywords: Occupational Safety and Health, Legislation, Comprehensive way of life, Shura

1.0 INTRODUCTION

This paper attempts to discuss the issue of occupational safety and health from the Islamic perspective. It is important in understanding how Islam provides a complete and comprehensive way of life leading to a balanced way of living. Islam establishes systems of laws that integrate all domains of human life to bring happiness and peace to all its members. Hence, Islam is a code of life that governs the Muslims in all aspects of life be it spiritual, intellectual, personal, family, social, economic, political and so forth. Islam even has laid out the guidelines on safety and health at the workplace, which will be discussed in detail in this chapter.

Islam is not a mere religion; it is a way of life. The word "Islam" originated from the Arabic root word which means "total surrender", "submission", "obedience", "purity of heart" and "peace". Thus, the meaning of Islam itself means complete submission to the will of Allah (SWT) in all aspects of life. Islam teaches that people can only find peace in one's life by submitting to Allah (SWT) in heart, soul, and deed. Allah says:

"Indeed, the religion in the sight of Allah is Islam. And those who were given the (Nik Mutasim Nik Ab. Rahman & Sharmin Shahid, 2009).

Scripture did not differ except after knowledge had come to them - out of jealous animosity between them. And whoever disbelieves in the verses of Allah and then indeed, Allah is swift in [taking] account" (Surah Ali Imran, 3:19).

It is the primary aim in life that a Muslim to worship Allah, the Creator of the Universe, so as to succeed both in this life and in the life hereafter. To a Muslim, the whole purpose of life is “ibadah” which means worshipping the Almighty Allah (SWT) that includes any acts of obedience to Almighty Allah (SWT). Islam is a comprehensive religion that relates to and guides its followers in all facets of their lives. Allah (SWT) says:

“... *This day I have perfected for you your religion and completed My favour upon you and have approved for you Islam as your religion...*” (Surah al-Ma'idah, 5:3)

This shows that the principles and institutions of Islam are comprehensive. They include the whole of human existence, emotions, thoughts, actions, worship, economic dealings, social relationship, spiritual demand and every other value which are based on the rules of wisdom for the welfare and betterment of mankind. As earlier stated, Islam is a complete way of life. Islam not only reflects the relations between the Creator and human beings, but the deliberation encompasses the relation between man and man; and man and the entire universe. Thus Islam provides general principles and general guidelines that cover all aspects of life, be it a commercial dealing (*muammalah*), worship (*ibadah*), criminal act (*jinnayah*), property matters (*Mal*), matters concerning marriage (*munakahat*) and so forth.

1.1 Mankind as Caliph

Almighty Allah (SWT) creates mankind to be His Caliph (*Khalifah*). In English, the Arabic word 'Khalifah' is often translated as 'vicegerent'. Vicegerent means one who acts in the place of the leader or king. Included in the meaning of vicegerent is the assumption that the person in that role will act in every instance as the leader or king would want them to act (Mustaffa Mohamed Zain et al., 2014). Thus, Allah (SWT) created mankind to be His representative on earth. Hence it is expected that mankind shall act in all circumstances as prescribed by Allah (SWT). The term “vicegerent” is mentioned even before the creation of Adam, the first human being. In the Surah Al-Baqarah, 2:30:

“ *And recall when your Lord said to the angels: “ Surely I am going to place a vicegerent on earth.” They said: Will You place therein one who will act corruptly therein and shed blood, while we hallow Your praises and glorify You? Allah said: Verily I know what you do not know.*”

As a vicegerent, the human being is deemed as the trustee of the earth. The Quran refers to the term “caliph” or vicegerent to every individual man or woman as Allah’s agent on earth and Allah’s trustee. Great responsibilities are imposed on the human beings that serve to test their accountability and submission to Almighty Allah (SWT). Human beings are to submit to Almighty Allah (SWT) and to accept that Allah is the ultimate owner of everything on earth and everything in the whole universe. Thus, the believers (Muslims) must act correctly in their relations with Allah, with other human beings and the universe. He is not supposed to cause corruption in any form on earth that may endanger him and/or the public at large (Hoque, 2011). It is followed by either reward or punishment. Submission to Allah (SWT) will motivate Muslims to lead a good and meaningful life in this world and attain contentment and pleasure in the Hereafter.

1.2 Sources of Shari’ah (Islamic Law)

Islam is “syumul” which means a comprehensive way of life whose teachings cover, direct or indirectly, every possible human relationship. The Islamic teachings are primarily instituted in the two main sources of its teachings, the Qur’an (the words of Almighty Allah) and the Sunnah (a collection of sayings of the Prophet Muhammad (SAW) and accounts of Prophet Muhammad’s daily practice). There are secondary sources of Islamic sources, namely the Ijma' (consensus) and Qiyas (analogy). Fiqh maxims also form as guidance in determining a solution to a particular issue as long as they do not contradict the Quran and Sunnah (Doi, I. Abdur Rahman, 1997).

The Holy Qur’an and Sunnah are the basis for the Shari’ah (Islamic Law) and norms for mankind to adhere to. The Shari’ah, being an integral part of revelation, is a guide for human action covering every aspect of social, political, cultural and economic. The term “Shariah” literally means ‘the way to a watering-place’. It is the path not only leading to Allah (SWT) but the path believed by all Muslims to be the path shown by Allah (SWT) through His Messenger, Prophet Muhammad (SAW). In Islam, Allah alone is sovereign. It is Allah who has the right to ordain a path for the guidance of mankind.

2.0 METHODOLOGY

This study attempts to explore the congruency between Islamic principles and existing OSH legislation. This study adopts a doctrinal legal method which deploys legal proposition, doctrines, principles and legal concepts. Apart from referring to the Qur'an to determine the verses relating to OSH, a doctrinal legal researcher uses statutes, rules, and cases to understand the legal issues. Thus, the Factory and Machinery Act 1967 (Act 139) and the Occupational Safety and Health Act 1994 (Act 514) are used extensively.

3.0 ISLAMIC VIEW RELATING TO WORK

By having a universal and complete worldview, Islam believes in freedom, justice and equality regardless of class, creed or skin colour. Islam has its own view about work and has placed great importance on work. Islam prohibits discrimination, intolerance and injustice in the workplace. Based on the Qur'an and Sunnah, it is undeniable that Islam demands that employers are to treat the employees equally, justly and with dignity, honour and respect. The employees are duty-bound to reciprocate the employers by adhering to the employers' instructions.

Islam grants work a high status and has made it obligatory for all physically and mentally capable people. Islam requires work to be performed based on a contract which reflects justice and responsibility on both the employer and the employee. Work in Islam is not merely as a means to provide for the employee himself and his family, but it is also meant to sustain social prestige, to advance societal welfare and reaffirm faith. It is a religious obligation to work which is also an act to manifest the Muslims' subservience to Allah, hence work is also an act of ibadah (worship). Every Muslim believes that he will be held accountable on the Day of Judgement.

Islam views work as an important part of human life. The Qur'an promulgates the fundamental principles regarding the role of labour, as described in the Qur'an in these words, "And a man shall not deserve but (the reward of) his own effort" (al-Najm, 53:39). Prophet Muhammad (SAW) made it clear to his companions that the dignity of a human being is tied up with his work. Prophet Muhammad (SAW) said that "God loves those who work for their livelihood" and "to search for lawful earning is obligatory after the compulsory things (like prayer, fasting, and belief in God)" (Hayat, 2018).

3.1 Islamic Principles On Employer-Employee Relationship

It should be known that Islam advocates the protection of the safety and health of employees at the workplace, though not in the exact name of occupational safety and health, its connotations could be found in the Islamic teachings. Islam has high regard for the safety and health of the employees; something that can be found in the Qur'an and the Sunnah. Islam has detailed the rights of employers and employees.

The Qur'an ordains its followers to be kind to each other, as can be seen from these words:

"But on account of their breaking their covenant, We cursed them and made their hearts hard; they altered the words from their places and they neglected a portion of what they were reminded of, and you shall always discover treachery in them excepting a few of them; so pardon them and turn away; surely Allah loves those who do good (to others)"
(Surah Al-Maidah 5:13).

A supervisor is morally bound not to mistreat those below her or him in the chain of command (Syed, 2008). The Prophet said: "One who mistreats those under him will not enter paradise" (Tirmidhi as cited in (Nik Mutasim Nik Ab. Rahman & Sharmin Shahid, 2009).

). The Prophet (PBUH) highlighted the importance of work in his sayings as below:

"no one eats better food than which he eats out of his work".
"Whoever goes to bed exhausted because of hard work, he has thereby caused his sins to be absolved"

According to Islam, there is a corresponding right for each obligation. There is a one-to-one correspondence between the obligation of an employer and employee. Therefore, there must be endeavours to meet the obligations at the same time, achieving and fulfilling correspondent rights (Akhtar, 1992). An individual's effort to meet up with his obligations will eventually lead to the fulfilment of everyone's rights. Hence, an employer strives to perform his duties and a similar act is reciprocated by the employee, the good relationship between both parties will be enhanced which will eventually lead to a better environment at any workplace.

Islamic law is unbiased, as it preaches fairness and justice in every activity of life among human beings, without discrimination, irrespective of status or position between counter-parties in agreements or contracts. There is no partiality in Islam in the treatment of an employee over an employer nor an employer over an employee, because Islam treads the path of justice and fairness and therefore, requires all of mankind to equally live in abundance and dignity to ensure peace and stability (Abdullah Mohamed Seidu, 2009; Hoque, N.,2011). A God-fearing Muslim will strive his best to adhere to Allah's ordains and Sunnah as every Muslim believes that he will be held accountable on the Day of Judgement, as stated:

“And if Allah please He would certainly make you a single nation, but He causes to err whom He pleases and guides whom He pleases, and most certainly you will be questioned as to what you did” (Surah An-nahl, 16:93).

4.0 ISLAMIC TEACHINGS AND OSH LEGISLATION

The Islamic principles concerning the employer-employee relationship are in line with the teachings of the Quran and Sunnah. Shafi'i maintains that employers and employees are individuals who belong to the same brotherhood and enjoy equal social status. It is important that the employer and employee adhere to the Islamic principles to achieve a harmonious relationship in the workplace.

4.1 ISLAMIC TEACHINGS

Brotherhood is a salient characteristic of Muslims. According to Islam, if one finds something good in his brother, he should encourage and help him in that good thing and if he detects a shortcoming in his brother, he should advise his brother confidentially and exhort him to repent and return to more correct behaviour or attitude. The brotherhood should be built on cooperation and meeting each other's needs in both comfortable and difficult times. The Prophet Muhamad (SAW) said: "The example of the believers' love, affection, and mercy for one another is like that of the body: when one of its organs ails, the rest of the body responds and watches over it by contracting fever." (Bukhari and Muslim). In Islam brotherhood is a responsibility; each brother has a right on the other. Below are Allah's words:

“O you who have believed, fulfill [all] contracts. Lawful for you are the animals of grazing livestock except for that which is recited to you [in this Qur'an] - hunting not being permitted while you are in the state of ihram. Indeed, Allah ordains what He intends” (Surah Al-Maidah, 5:1).

Islam unites all individuals in the bond of universal brotherhood (ukhuwah). All individuals are treated as if they were members of one single family.

“And (as for) the believing men and the believing women, they are guardians of each other; they enjoin good and forbid evil and keep up prayer and pay the poor-rate, and obey Allah and His Messenger; (as for) these, Allah will show mercy to them; surely Allah is Mighty, Wise” (Surah al-Tawbah, 9:71).

Prophet Muhamad (SAW) says that “Mankind is the family of Allah and the most beloved of them before Him is the one who is best to his family.” Therefore, each and everyone within the brotherhood is entitled to equal social status. The brotherhood implies cooperation and mutual help with one another as pointed by the Qur'an:

“O you who have believed, do not violate the rites of Allah or [the sanctity of] the sacred month or [neglect the marking of] the sacrificial animals and garlanding [them] or [violate the safety of] those coming to the Sacred House seeking bounty from their Lord and [His] approval. But when you come out of ihram, then [you may] hunt. And do not let the hatred of a people for having obstructed you from al-Masjid al-Haram lead you to transgress. And cooperate in righteousness and piety, but do not cooperate in sin and aggression. And fear Allah; indeed, Allah is severe in penalty” (Surah al-Ma'idah, 5:2).

Based on the above ayats and hadiths, it can be summed up that employers and employees are individual members of one brotherhood regardless of the differences in educational attainment, age, and so forth. All individuals thus deserve to enjoy some degree of respect, love and social status. Islamic principles prohibit the oppression committed by the employer upon his employees. In a conventional economics environment, an employer is presumed to be in power and in a stronger position compared to the employees. It is apparent that the Islamic concept of brotherhood has eliminated the injustice and exploitation in society.

4.1.1 Employees' Safety

The teachings of Islam represents the first principal guide for inviting man to observe (workplace) security and safety measures and Islam has long surpassed the Industrial Revolution by centuries by calling for workers' safety

(Rozanah Ab Rahman, 2006). It is the basic right of every employee that employer must provide them safe and healthy workplace (Hayat, 2018). Allah has ordained: "If anyone saves a human life, it shall be as though he had saved all mankind" (Surah Al-Maidah, 5:32). Allah says in Surah Al-Maidah, verse 195:

"...make not your own hands contribute to (your) destruction."

The above ayats (verses) confirm that Islam has forewarned not to contribute to destruction as it would be against Allah's ordains. It could be applied in the workplace whereby it is fundamental to prevent unwanted accidents. This is akin to the concept of HIRARC (Hazard Identification Risk Assessment and Risk Control). The duty to ensure the safety of employees can also be found in preservation of life (al-Nafs) laid out in Maqasid Shari'ah (Auda, 2008, Muhammad Adil Khan Afridi, 2016).

4.1.2 Employees' Health

Islam has honoured health as a fundamental right of every human being. Protection of health is an important condition for the preservation of life (al-Nafs). Prophet Muhammad (SAW) is quoted as saying: "wealth is of no harm to a God-fearing person, but to the God-fearing person, health is better than wealth". This saying can be applied in the employment relations that health is very important, be it physical or mental health. It is important not to cause harm to others as the sayings of Prophet Muhammad (SAW): "There shall be no infliction of harm on oneself or others". Prophet Muhammad (SAW) also says: "You must refrain from dealing wickedly with others, for that would count as a benefaction you do to yourself". In the Qur'an, Luqman advised his son saying:

"And pursue the right course in your going about and lower your voice; surely the most hateful of voices is braying of the asses" (Surah Luqman, 31:19)

The above ayat (verse) shows that a man should not be subjected to loud and annoying noises to prevent harm to him both physically and psychologically. It could be applied to current workplace activities. Proper personal protective equipment (PPE) must be provided in the workplace to protect fellow employees from noise pollution or other hazards that could endanger them. As earlier mentioned, the Muslims are to treat others as brothers of each other. Thus, a man would not cause harm to others. One should try to remove any danger to another. Health is not solely confined to physical health. It refers to mental health as well.

4.1.3 Employees' Welfare

Islam guarantees one's basic needs, ensuring humane workloads and working conditions, and extending brotherly treatment to his employees. Any employer, who humanely, treats his employees will eventually find that his employees become more conscientious and loyal to him. The Prophet Muhammad (SAW) said: "Suffer no loss to yourselves nor make others suffer". The Prophet Muhammad (SAW) also warned: "Those who expose their servants to ill-treatment will find the Paradise gates shut to their faces". In Surah al-Qasas, verse 27, the employer (Prophet Shu'ayb, A. S) told the employee (Prophet Musa A.S) that: "...I do not make it hard for you; you shall find me, Allah willing, of the righteous."

Thus, it is obvious from the above hadiths and ayat that Islamic principles prohibit the employer from assigning excessive work that may overburden the employee. An employer cannot be righteous if he does not alleviate his employees from unnecessary burdens. The above verse from the Qur'an shows that a person must have towards his fellow human beings. Employers' humane treatment of his employees could bring great rewards to the organisation.

If the amount of work is beyond the employee's capability, hence the employer must render his assistance so that the employee will be able to complete the task. It is explained in detail by a hadith narrated by Bukhari (Hayat, 2018):

"Your brethren are your servants whom Allah has made your subordinates. So the man who has his brother as his subordinate should give him to eat from what he himself eats, and wear what he himself wears. And do not put on them the burden of any labour which may exhaust them. And if you have to put any such burden on them, then help them yourselves (in this work)."

The above hadith explicitly specifies the prohibition of an excessive amount of work or task that is impossible for an employee to be able to carry it out successfully. Therefore, the employer has to think deeply before assigning a task or work to an individual employee. Otherwise, he is bound to facilitate his employees in order for the task or work to be accomplished within the expected time frame. Similarly, an employer has to consider whether such work or task entails occupational hazards as it is the Islamic principles not to endanger a fellow brother.

In adhering to Islamic principles on how to treat the employees, it is mentioned in the above paragraph that employers must not overburden the workload of their employees. In order to identify whether the employees' workload is reasonable or not, employers are therefore needed to understand the nature of employees' work or tasks. In so doing, the employers are expected to determine the reasonable hours of work needed to complete the task or work. The employers also need to ensure that the task or work assigned to the employees does not entail any hazard that might be dangerous to the employees' wellbeing. To serve God or to worship Him is a comprehensive way that covers every aspect of life. Fulfilling all that God has demanded from us in terms of praying, fasting, zakat and hajj indicates worshipping. The same could be said regarding any action that the human being performs following the Islamic world-view, as long as it is done for the sake of God.

4.1.4 Cooperation Between Employer And Employee

In Islamic principles, all members of an organisation are encouraged to cooperate to achieve the organisation's objectives. Without proper cooperation among organizational members, it is not possible to achieve the goals of the organization smoothly. Considering the necessity of cooperation in human life the Prophet Muhammad (SAWS) stated that, "The best of people are those who benefit others". The Prophet Muhammad (SAWS) also says, "Allah shows no mercy to them who are not merciful to the people" (Rozanah Ab Rahman, 2006). This is a very special feature of Islamic principles where mutual cooperation would be practised for the betterment of individuals themselves as well as organization. Absolute cooperation from all parties in an industry can ensure a good and sustainable relationship which ultimately leads to better productivity and profitability of the organization.

The Quran has made it clear that Muslims are obligated to consult those who have the knowledge or those who can provide sound advice. Allah says:

"And those who answer the call of their Lord and establish prayer, and who conduct their affairs by consultation and spend out of what We bestow on them for sustenance"
(Surah As-Syura, 42:38)

The Prophet Muhammad (SAW) regularly consulted his companions on all important matters. The Prophet (SAW) was ordered to take counsel from and consult with them as in Surah Al-Imran, verse 159:

"and consult them on affairs (of the moment). Then, when you have taken a decision to put your trust in Allah."

The Prophet Muhammad (SAW) sought his companions to find out their opinions in all affairs before making any final decisions. The most outstanding example of the Prophet's (SAW) Shura occurred on the eve of the Battle of Uhud. While the Prophet was thinking that the city should be defended from within, the majority wanted to go out to fight. The Prophet accepted this and did not impose his own opinion on his companions. Abu Hamzah Anas ibn Malik (RA), who was the servant of Prophet Muhammad (SAW) reported that the Prophet (SAW) said: *"None of you truly believes (in God and His religion) until he loves for his brother what he loves for himself"* (Reported in al-Bukhari and Muslim as cited in Jawad, 2008).

The above Qur'an verses and Hadith envisage clear principles that Islam commends consultation and seeking the consensus of stakeholders before reaching a decision. As earlier mentioned, a Muslim must treat his employees as if they are his brothers. Thus, Islamic principles promote consultation (Shura). By consulting and obtaining consensus from the employees before establishing rules and regulations at a workplace, it shows that the employers are open to the feedback given by the employee. It will also make the employees feel that they are integral to the organisation. Consultation among members at different levels in an organisation makes employees feel important and part of the system. It attests that the consultative decision-making culture will improve the quality of decisions on one side and the other side it will develop a relationship between the employer and employees. As a result, the employees will get inspiration in carrying out their duties and responsibilities. Furthermore, the consultative culture will wipe out the seed of selfishness and egoism which are forbidden in Islam.

4.1.5 The Enforcement Of The Rules And Regulations

It is observed that there are certain basic differences between the purpose and scope of the law in today's sense and in the sense of the Quran. Laws in today's sense are specific rules governing the social, economic and political affairs of a nation made by a competent authority and enforced by the sanctions of a state (Nik Mutasim Nik Ab. Rahman & Sharmin Shahid, 2009).

The state law and the organisation's rules and regulations are already in place, the employer should enforce them. Failure to enforce them will indicate that the employers are not serious thus fail to earn respect from the employees. Therefore, employers should take all types of initiatives to make the workers disciplined and cultured. If anyone violates the disciplines of the organization intentionally there should have a system of punishment based on the degree of offences. In Islamic principles, the punishment administered by the organization is for the purpose of (i) reforming the guilty party and (ii) safeguarding the organization from the impact of his mischief (Syed, 2008). But for an unintentional mistake, they should not be penalised. As reported by Abu Dawud, Prophet (SAW) said *"If you made intercession, you will be rewarded"* (Nik Mutasim Nik Ab. Rahman & Sharmin Shahid, 2009).

4.2 OSH LEGISLATION IN MALAYSIA

The objective of this study is to explore the congruency between Islamic principles and existing Malaysian OSH legislation. Thus, a brief background of OSH in Malaysia will be explained.

4.2.1 Background of Legislation

OSH in Malaysia is governed by the Factory and Machinery Act 1967 (Act 139) (hereafter will be referred to as FMA) and the Occupational Safety and Health Act 1994 (Act 514) (which is referred to as OSHA) together with the supplementing regulations. Both statutes are administered by the Department of Occupational and Health under the purview of the Ministry of Human Resource. The philosophy between FMA and OSHA differs. The former has limited application as compared to the latter.

4.2.2 The Factory and Machinery Act 1967 (Act 139)

The Factory and Machinery Act 1967 (Act 139) (hereafter will be referred to as FMA) is governed by the Department of Occupational Safety and Health (DOSH). FMA is based upon the UK legislation. Its application was limited to four industries, namely, manufacturing, construction, mining & quarrying, and agriculture. FMA is very prescriptive as it has provided detailed requirements in the parent Act and its Regulations. For example, Section 25 FMA covers the provisions concerning welfare which is to be read together with the Factories and Machinery (Safety, Health and Welfare) Regulations 1970 (Revised 1988). Regulation 9 provides that stairway must not be less than thirty-six inches wide and other details. Regulation 23 provides detailed provisions concerning cleanliness, to the extent that the floor shall be cleaned at once a week. Regulation 34(3) provides that in a factory that has fifteen or more women employees, thus the employer shall provide at least one rest and dressing room for their exclusive use. Regulation 34 relates to the supply of drinking water. FMA is mainly concerned with the safety aspects of the workers in the listed industries and safety aspects of the machinery used in workplaces covered by its application. FMA places the burden upon DOSH officers to inspect the machines to ensure that they are safe.

4.2.3 Occupational Safety and Health Act 1994 (Act 514)

By the late 1960s, it became apparent that many of these UK regulations were essentially unsuccessful because the number of workplace injuries did not decline. The UK government commissioned Lord Roben to form a Committee on Safety and Health at Work in the early 1970s to review the existing laws on health and safety. The Roben's recommendations formed the basis for the new OSH legislature in the UK. In 1974, a new OSH legislation was established, the Health and Safety at Work Act 1974 (HASAWA).

The implementation of HASAWA has prompted the Government of Malaysia to review its existing OSH legislation. It resulted in the implementation of the Occupational Safety and Health Act 1994 (Act 514) which is referred to as OSHA. In the event of any discrepancy between FMA/other laws and OSHA, OSHA will prevail, Section 2(2) OSHA. OSHA nevertheless is more flexible and encourages self-regulation. OSHA is based on the philosophy that the responsibility to ensure safety and health lies with those who create the risk and those work with the risk. OSHA 1994 has wider coverage as it covers not only the employers and occupiers but self-employed person, designers, manufacturers, importers and suppliers any plants (section 20) and duties are also placed upon a person who formulates, manufactures, imports and supplies any substances for use at the workplace. OSHA's coverage is wider that encompasses public sector and statutory authorities as stated in its First Schedule.

OSHA's underlying principle is self-regulation. It means that the government lets employers and employees decide the best practices for their respective organisations. Hence, the system of work and training may differ from one company to another. This is where the safety committee comes into the scene (Ummu Kolsome et al., 2011). The existence of a safety committee is akin to the Islamic concept of Shura.

Section 15(2) provides that the employers are legally bound to their employees in ensuring a safe workplace and safe system of work which includes proper maintenance. The employers shall disseminate information, provide training and supervision of his employees. Finally, the employers shall provide and maintain the working environment and facilities at the workplace to ensure that the employees' welfare is taken care of. For instance, the employer may provide a pantry or a prayer room (if there are many Muslim employees), providing clean drinking water by installing water dispenser and so forth.

Every employer is required to establish a safety and health committee if there are forty or above workers; or as directed by the Director-General, Section 30. A safety committee consists of a representative of the employers and employee. The functions of such a committee are to make recommendations to promote and develop measures to ensure the safety and health at the workplaces and to monitor the effectiveness of such measures, Section 31. The principles underpinning the safety committee are to encourage interaction between the parties and help improve trust and communication. This provision promotes the workers' participation in the effort to achieve safe and healthy workplaces. The employers are expected to work closely with their employees to improve safety and health at their establishment

5.0 CONCLUSION

The above discussion has explained the salient features of Malaysian OSH legislation such as the underlying principles of self-regulation and legal duties of employers and employees to ensure that the workplace is safe. Therefore suffice to say that the existing OSH legislation is incongruent with Islamic principles.

Islam propagates a society based on social justice, equity, moderation, and balanced relationships. Islam is not a mere religion, but it is a complete way of life which is based on the commandments of Allah contained in the Holy Quran and the Sunnah of the Prophet Muhammad (SAW). Islam is a practical system of life hence Islamic teachings are a complete system on how one should act. Islamic principles represent eternal values and prohibit exploitation. The Islamic principles aim to safeguard the rights of all individuals, and at the same time, reminding them of their obligations to themselves and society at large. Every Muslim must shape his entire life following the Islamic principles found in the Holy Quran and the Sunnah. Thus, every Muslim must observe Allah's commandments at every step so that he will be blessed in this world and the Hereafter. Islamic teachings strictly forbid an employer from over-burdening his employees. Similarly, Islamic teachings prohibit an employer from allocating dangerous and degrading work to his employees.

In short, Islamic principles protect the employees' interest without denying the employers' rights as each individual in a society is treated as brothers to the others. In a brotherly environment, each individual has a role to fulfil in line with the Islamic teachings. A healthy employer-employee relationship is crucial for several mutual benefits for both sides. It is concluded that Islamic teachings aim to allow people to earn their living fairly and profitably without the exploitation of others, so that the whole society may benefit. By understanding one's role and obligation, a harmonious and healthy relationship is established between the employers and employees. A holistic system that can be found in Islam in teachings aims at contributing to the fulfilment of the social-economic objectives and creation of just society, which will bring lasting balance between employers and employees to achieve betterment for the whole community. Islamic principles aim in bringing a balance between the rights of individuals and their duties (inclusive responsibilities) towards others, and between self-interest and altruistic values. Every act, as long as it is good [e.g. protecting the employees] and done for the sake of Allah [SWT], is considered an act of worshipping that generates a reward in this life and the hereafter.

Islam is a comprehensive religion (syumul) thus it covers a practical system of life and it guides all aspects of life be it from individual perspective or community, economic, political and includes shariah, muamalah (commercial), akhlak (behaviour) and aqidah (worship). Islam provides clear guidelines and principles. Islam emphasizes the physical and spiritual aspects of maintaining justice and peace amongst mankind as stipulated in al-Quran and al-Sunnah. In upholding justice amongst mankind, it is important to observe and adhere to Islamic teachings as it is the ultimate goal of mankind being the Khalifah. The discussion shows that Islam views OSH in a different perspective. Both the employers and employees are bound to ensure that they carried out their duties not merely for the sake of dollars and cents, but the obligation to take care of each other so that every Muslim will be accordingly rewarded on the Day of Judgement. Based on the above deliberation, it is concluded that the current Malaysia OSH legislation is congruent with the Islamic principles.

References

- Abdul Ghafar Ismail, Shahida Shahimi, & Bayu Taufiq Possumah (2011). Bringing Work Back in Islamic Perspectives, *Prosiding Persidangan Kebangsaan Ekonomi Malaysia ke VI (PERKEM)*, Melaka 5-7 Jun 2011, 2: 247-262.
- Abdullah Mohamed Seidu (2009). Islamic Concept of Employer-Employee Relationships: An Instrument for Managing Human Resources and Certain Operational Risk Exposures, *Legon Journal of Sociology*, 3(2): 45-69.
- Abdulrahman Raden Aji Haqqi (2009). *The Philosophy of Islamic Law of Transactions*, Kuala Lumpur, Cert Publications.
- Abdus Sattar Abbasi, Kashif Ur Rahman & Sabir Hussain Abbasi (2010). Welfare and Protection Model for Organizational Management: The Islamic Perspective, *African Journal of Business Management*, 4(5):739-747.
- Akhtar, M. Ramzan (1992). An Islamic Framework for Employer-Employee Relationship, *The American Journal of Islamic Social Sciences*, 202-218.
- Aldulaimi, S. Hameed (2016) Fundamental Islamic Principles of Work Ethics, *Journal of Islamic Accounting and Business Research*, 7(1):59-76.
- Auda, J. (2008) *Maqasid Al-Shariah as Philosophy of Islamic Law; A Systems Approach*. London: The International Institute of Islamic Thought
- Ali Alkahtani (2014). An Application of Islamic Principles in Building a Robust Human Resource Management System (In Islamic Countries), *International Journal of Recent Advances in Organizational Behaviour and Decision Sciences*, pp.183-194. .
- Dawson, S., Willman, P., Clinton, A. & Bamford, M (1988) *Safety at Work: the Limits of Self-regulation*, Cambridge: Cambridge University Press.
- Denzin, N. K. & Lincoln, Y. S. (2000). *Handbook of Qualitative Research* (2nd ed.). London: SAGE Publication.
- Doi, Abdur Rahman I. (1997). *Shari'ah: The Islamic Law*. London: Ta-Ha Publishers.
- Goetsch, D. L. (2011). *Occupational Safety and Health for Technologists, Engineers and Managers* (7th ed.) New Jersey: Prentice Hall.
- Hart, S. M. (2010). Self-regulation, Corporate Social Responsibility, and the Business Case: Do They Work in Achieving Workplace Equality and Safety? *Journal of Business Ethics*, 92(4):585-600.
- Hayat, A. (2018) Occupational Safety in Islamic Perspective, *Journal of Islamic Thought and Civilisation*, 8(1):178-191.
- Hoque, N. (2011). Industrial Relations- An Islamic Approach, *IIUC Studies*, 8:39-58.
- Khairiah Soehod (2008). Workers' Participation in Safety and Health at Work, *Jurnal Kemanusiaan*, 11:8-16.
- Mahazirah Mohamad & Nor Azman Mat Ali (2016). *Quality of Life Maqasid Shariah Approach*, Kuala Terengganu: Penerbit Universiti Sultan Zainal Abidin.
- Malaysian Trade Union Congress (MTUC)(2001). OSH Legislation and its Implementation, http://www.mtuc.org.my/osh_profile_malaysia.htm.
- Muhammad Adil Khan Afridi (2016) Maqasid Al-Shari'ah and Preservation of Basic Rights, *Journal of Education and Social Sciences*, 4:274-285.
- Mustaffa Mohamed Zain, et al. (2014). Corporate Ibadah: An Islamic Perspective of Corporate Social Responsibility, *Middle-East Journal of Scientific Research*, 22(2):225-232.
- Nik Mutasim Nik Ab. Rahman & Sharmin Shahid (2009). Islamic HRM Practices and Employee Commitment: A Test among Employees of Islamic Banks In Bangladesh, *Graduate School of Business*, Universiti Kebangsaan Malaysia, 1269-1278, accessible <http://wbiconpro.com/455-Nik.pdf> retrieved on 12/02/2016.
- Rahmad Hakim and Elvan Syaputra (2012) Business Al-Amanah and the Responsibilities of Islamic Business Managers, *La_Riba*, 6(2): 199-210.
- Rozanah Ab Rahman (1999). Safety Systems at Work: The Employer's Duty, *ILR i*.
- Rozanah Ab Rahman (2006). Protection of Safety, Health and Welfare of Employees at Workplace under Islamic Law, 14(1) *IUMLJ* 51-66.
- Syed, J. (2008). An Islamic Perspective of Industrial Relations: the Case of Pakistan. *Journal of Management, Spirituality and Religion*, 5(4): 417-440.
- Ummu Kolsome Farouq, et al. (2011). Joint Occupation Safety and Health Committees: Extent of Functioning in Malaysian Manufacturing Companies? *IPEDR* 10:521-525.

PUNCA TEKANAN KEWANGAN PERIBADI DI MALAYSIA: SATU PENELITIAN FENOMENOLOGIKAL

Ahmad Azrin Adnan^{a*}, Junainah Ahmad Esa^b, Mohamad Izzuddin Abdul Aziz^c

^{a,c}*Fakulti Perniagaan dan Pengurusan Universiti Sultan Zainal Abidin (UniSZA), Malaysia*

^b*Agensi Kaunseling dan Pengurusan Kredit (AKPK), Malaysia*

Abstrak

Perancangan kewangan yang lemah lazimnya menjadi punca utama tekanan kewangan individu di Malaysia. Pendekatan fenomenologi yang dijalankan ini sebaliknya menemui punca utama yang lain. Penemuan ini melahirkan pula punca lain yang jarang ditemui dalam penelitian terdahulu. Kertas ini cuba menjelaskan punca tekanan kewangan dalam kalangan individu yang hampir bankrap di Malaysia menerusi pendekatan fenomenologi. Seramai tiga orang peserta terlibat dalam pemerhatian turut serta dan temu bual secara mendalam. Pengelasan data fenomenologi dalam bentuk tema yang lebih khusus dianalisis menerusi kaedah perbandingan berterusan. Penelitian ini mendapati bahawa tasawur atau acuan kepenggunaan yang tidak tepat lebih besar pengaruhnya ke atas tekanan kewangan individu berbanding perancangan kewangan yang lemah. Ketidaktepatan tasawur kepenggunaan ini melahirkan pula unsur mistik sebagai punca yang jarang diwacanakan. Penemuan ini telah memperlihatkan betapa perlunya menilai semula aspek pembudayaan gaya hidup yang lestari di Malaysia.

Keywords: Bankrap, isi rumah, muflis, literasi kewangan, tekanan kewangan

1.0 PENGENALAN

Walaupun isu tekanan kewangan dalam kalangan individu telah lama dikaji seperti yang dilakukan oleh Cuvillier (1979), Newacheck dan Halfon (1986) dan Gordon et al. (1986), ia masih dianggap isu semasa. Malah menjadi lebih ketara dalam suasana kegawatan ekonomi. Pandemik COVID-19 yang kini melanda hampir seluruh dunia misalnya telah memberi kesan yang amat mendalam kepada survival ekonomi negara amnya dan isi rumah khususnya. Buktinya, kajian yang dijalankan pada 18 hingga 31 Mac 2020 oleh Jabatan Perangkaan Malaysia ke atas 168,182 responden yang berusia sekurang-kurangnya 15 tahun bagi menilai impak COVID-19 terhadap ekonomi dan individu telah mendedahkan setidaknya-tidaknya lima realiti. Pertama, hampir 53 peratus responden mengalami tekanan kewangan terutamanya dalam tempoh Perintah Kawalan Pergerakan. Kedua, sebanyak 71.4 peratus responden yang bekerja sendiri mempunyai simpanan yang hanya mencukupi kurang daripada sebulan. Kedua, simpanan kewangan bagi 69.7 peratus responden yang telah bekerja dalam tempoh kurang daripada setahun dan 63.2 peratus responden yang bekerja dalam tempoh 1 hingga tiga tahun masing-masing hanya mampu bertahan kurang daripada satu bulan. Ketiga, hampir 47 peratus responden yang bekerja sendiri kehilangan pekerjaan berikutan pelaksanaan Perintah Kawalan Pergerakan bagi mengekang penularan COVID-19. Keempat, hampir semua responden yang bekerja sendiri mengalami pengurangan pendapatan bulanan. Walaupun dapatan kajian ini perlu ditafsir secara berhati-hati kerana keterbatasan dalam beberapa aspek metodologi, paling tidak ia dapat memberi gambaran tentang situasi semasa. Keempat-empat realiti ini memperlihatkan betapa besarnya impak COVID-19 terhadap tahap tekanan kewangan hingga mampu menjejaskan kesihatan emosi dan fizikal, sekali gus merencat keharmonian isi rumah. Kesignifikan hubungan antara tekanan kewangan dan kesihatan emosi serta fizikal ditemui dalam kajian Gale, Goetz dan Bermudez (2009), Siah-push et al. (2014) dan Sturgeon et al. (2015).

Realiti di atas jika dibandingkan dengan pelbagai dapatan kaji selidik terdahulu misalnya Kaji Selidik Keupayaan dan Rangkuman Kewangan dari Sudut Permintaan 2018 oleh Bank Negara Malaysia (BNM) dan Kaji Selidik Tingkah Laku Kewangan Pekerja Dewasa Warga Malaysia 2018 oleh Agensi Kaunseling dan Pengurusan Kredit (AKPK), tidak memperlihatkan perubahan yang ketara dari segi tingkah laku kewangan khususnya pemilikan dana kecemasan dalam kalangan rakyat Malaysia. Sama ada dalam kalangan belia (Kamarudin, 2016) mahupun dewasa (Loke, 2017), tingkah laku kewangan yang ditonjolkan masih jauh daripada sasaran yang ditetapkan dalam Strategi Literasi Kewangan Kebangsaan 2019-2023. Ia membawa kepada persoalan tentang mengapa terjadinya tekanan kewangan sehingga membataskan keupayaan menabung dalam kalangan rakyat Malaysia.

Kaji selidik selama setahun yang dijalankan oleh Pusat Penyelidikan Kesejahteraan Sosial (SWRC) Universiti

Malaya pada tahun 2019 misalnya mendapati bahawa tekanan kewangan berpunca daripada perbelanjaan yang tidak terkawal. Perbelanjaan mereka yang melebihi jumlah pendapatan akhirnya mendorong mereka untuk berhutang. Perbelanjaan yang tidak terkawal dan aktiviti hutang yang tidak terurus ini jelas nya ada kaitan dengan perancangan kewangan yang lemah. Rumusan oleh SRWC ini sebenarnya memperkukuhkan lagi dapatan kajian selidik oleh AKPK (2018) dan BNM (2019) bahawa kelemahan perancangan kewangan menjadi penyebab utama tekanan kewangan individu. Realiti ini ditunjukkan oleh Rajah 1.

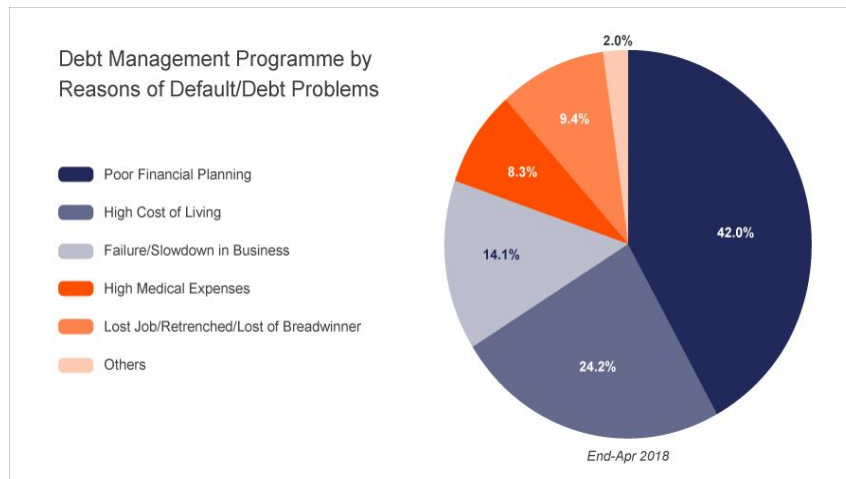

Rajah 1: Punca Permasalahan Pembayaran Balik Hutang
Sumber: AKPK (2018)

Berdasarkan Rajah di atas, hampir separuh daripada kes kemungkiran pembayaran balik hutang berpunca daripada perancangan kewangan yang lemah. Oleh sebab itu, kelemahan perancangan kewangan sering dianggap sebagai punca utama tekanan kewangan isi rumah di Malaysia.

Di sebalik kenyataan ini, timbul beberapa persoalan. Seperti yang didedahkan oleh Financial Education Network (FEN) menerusi Strategi Kebangsaan Literasi Kewangan 2019-2023 tentang kedudukan semasa literasi kewangan di Malaysia, sebanyak 76% rakyat Malaysia mempunyai belanjawan kewangan. Kajian Nuradibah et al. (2018) juga mendapati 93.5% responden bersetuju betapa pentingnya penyediaan senarai membeli-belah bagi mengawal perbelanjaan. Ini bermakna sebahagian besar rakyat Malaysia terdedah kepada ilmu perancangan kewangan. Lebih-lebih lagi bagi kelompok generasi yang berusia kurang daripada 55 tahun atau dikenali sebagai Generasi X, Y dan Z. Kelompok ini lazimnya mempunyai aksesibiliti yang lebih meluas ke atas bahan berkaitan misalnya menerusi platform dalam talian. Aksesibiliti yang lebih meluas terbukti dapat meningkatkan tahap literasi kewangan (Servon dan Kaestner, 2008). Realiti semasa di Malaysia bagaimanapun tidak mempamerkan kelaziman ini. Generasi baby boomers yang dikatakan rendah tahap literasi kewangannya (Visyalini et al., 2018), sebaliknya mempamerkan jumlah kes kebangkrutan yang lebih rendah berbanding generasi X, Y dan Z (Jabatan Insolvensi Malaysia, 2019). Generasi baby boomers ini jugalah yang mempunyai tahap tekanan kewangan yang lebih rendah berbanding generasi X, Y dan Z (AKPK, 2018). Senario ini menimbulkan persoalan tentang setakat manakah benarnya kelemahan perancangan kewangan sebagai punca utama tekanan kewangan.

Kertas ini cuba menanggapi semua persoalan ini. Ia berhasrat untuk memperdalam pengetahuan tentang punca tekanan kewangan dalam kalangan individu yang hampir bankrap di Malaysia menerusi pendekatan fenomenologi. Untuk itu, kertas ini akan menumpukan kepada empat perkara. Pertama, ia merumuskan punca tekanan kewangan yang telah ditemui dalam pelbagai kajian terdahulu. Kedua, ia menghuraikan metodologi yang terlibat dalam kajian ini. Ketiga, ia menganalisis punca tekanan kewangan yang ditemui dalam kajian ini. Keempat, ia menjelaskan hubungan antara realiti di lapangan dan falsafah yang mendasari setiap penemuan ini. Dapatan kajian ini diyakini dapat membantu usaha untuk membudayakan gaya hidup yang lestari dalam kalangan isi rumah di Malaysia.

2.0 TINJAUAN LITERATUR

2.1 Tekanan Kewangan

Punca tekanan kewangan peribadi kelihatan agak tepu berdasarkan pelbagai kajian terdahulu. Penelitian di pelbagai negara terarah kepada punca yang hampir sama dalam lima aspek berikut. Pertama, perancangan kewangan menjadi faktor paling penting yang menentukan kesejahteraan kewangan. Tinjauan Kesejahteraan

Kewangan di UK 2019 misalnya mendapati punca utama tekanan kewangan peribadi dalam kalangan warga UK adalah ketidakcukupan simpanan untuk menangani perkara di luar jangka. Faktor ini berkait rapat dengan perancangan kewangan. Punca lain yang ditemui dalam pelbagai kajian (Samer Al-Shami et al., 2019; AKPK, 2018); Rahman et al., 2018; Ware, 2015) seperti tahap hutang yang tinggi, kadar simpanan yang rendah, kekurangan pelaburan dan hutang kad kredit yang tinggi sebenarnya muncul daripada punca yang sama, iaitu kelemahan perancangan kewangan. Perancangan kewangan pula berkait rapat dengan aspek literasi kewangan. Pelbagai kajian terdahulu membuktikan wujudnya perkaitan yang signifikan antara literasi kewangan dan tekanan kewangan (Abdullah dan Razak, 2015; Delafrooz dan Paim, 2011; Joo dan Garman, 1999). Kedua, ketidakpastian pendapatan boleh guna memberi kesan kepada survival kewangan peribadi dan tanggungannya (Hira et al., 2013; Chan, 2012; Chan et al., 2010). Godinho (2019) meneliti kesejahteraan kewangan di Norway, Ireland, Kanada dan Australia. Menerusi penelitian ini, beliau mendefinisikan kesejahteraan kewangan sebagai kemampuan memenuhi komitmen dan keperluan serta berdaya tahan mengekalkannya pada masa hadapan. Ada tiga elemen penting berdasarkan pendefinisian ini, iaitu pendapatan, perbelanjaan dan pendapatan boleh guna (pendapatan individu ditolak potongan wajib seperti cukai). Sebarang punca tekanan kewangan seperti peningkatan kos sara hidup, peningkatan kos perubatan, kegagalan perniagaan, kehilangan pekerjaan dan persaraan lazimnya mempengaruhi jumlah pendapatan, perbelanjaan dan pendapatan boleh guna. Ketiga, peristiwa di luar jangka seperti perceraian, kematian ketua isi rumah, masalah kesihatan dan kemalangan juga diakui memberi tekanan kewangan. Kajian Samer Al-Shami et al. (2019) mendapati masalah kesihatan dan kehilangan ketua isi rumah menjadi antara penyebab utama kegagalan usahawan wanita di Malaysia. Situasi ini selanjutnya memberi tekanan kepada survival kewangan isi rumah. Keempat, polisi pihak pemiutang juga berupaya mempengaruhi tahap tekanan kewangan (Samer Al-Shami et al., 2019). Semakin ketat dasar kawalan kredit yang diamalkan oleh pihak pemiutang, semakin tinggi tekanan kewangan yang dihadapi oleh pihak peminjam. Kelima, terdapat pelbagai kajian yang mengupas isu ini dalam ruang lingkup Islam (Ahmad Azrin Adnan et al., 2018; Mohd Shukri Hanapi dan Siti Mastura Muhammad, 2017; Ahmad Azrin Adnan, 2012;). Ia berkait dengan tasawur atau acuan penggunaan yang akan menentukan ketepatan perolehan pendapatan dan pengagihan perbelanjaan. Kelima-lima penemuan di atas dirumuskan menerusi Jadual 1.

Jadual 1. Punca Tekanan Kewangan Isi Rumah

Punca	Sub-punca
Tasawur atau acuan penggunaan yang tidak tepat	<ul style="list-style-type: none"> • Belanja mengikut kehendak • Terlibat dalam aktiviti penipuan kewangan • Terlibat dalam aktiviti judi • Ketagihan dadah • Ketagihan arak
Tahap literasi kewangan yang rendah dan perancangan kewangan yang lemah	<ul style="list-style-type: none"> • Tiada atau kurang simpanan kecemasan • Tiada atau kurang pelaburan • Hutang kad kredit yang tinggi • Lemah pengurusan hutang
Ketidaktentuan pendapatan boleh guna	<ul style="list-style-type: none"> • Kos sara hidup yang tinggi • Belanja perubatan yang tinggi • Kegagalan perniagaan • Kehilangan pekerjaan • Persaraan
Peristiwa di luar jangka	<ul style="list-style-type: none"> • Perceraian • Kematian ketua isi rumah • Masalah kesihatan • Kemalangan
Polisi ketat pemiutang	<ul style="list-style-type: none"> • Tiada toleransi daripada pihak pemiutang

Sumber: Dirumuskan oleh penulis berdasarkan kajian terdahulu

Di sebalik kedudukan bahawa punca tekanan kewangan peribadi memperlihatkan kesimpulan yang hampir sama di pelbagai negara, sebilangan Sarjana berpendapat tekanan kewangan peribadi merupakan fenomena yang subjektif (O'Neill et al., 2006). Ia berdasarkan perbezaan sumber pendapatan dan corak perbelanjaan bagi memenuhi kepelbagaian keperluan dan kehendak. Kedudukan inilah yang menyebabkan munculnya gaya hidup.

2.2 Gaya Hidup

Gaya hidup merupakan konsep yang sering dibahas untuk memahami gelagat manusia (Kau Ah Keng et al., 1998; Mowen, 1995; Engel et al., 1993). Terdapat kajian yang melakukan pengkategorian tahap keberhutangan isi rumah mengikut gaya hidup masing-masing. Dalam kajian yang menumpukan aspek hutang, penggunaan kredit dan pengurusan kewangan keluarga, Viaud dan Levy (2000) mengkategorikan empat tahap keberhutangan isi rumah mengikut gaya hidup. Pertama, kelompok isi rumah yang berjimat cermat (*prudent household*) memiliki kriteria seperti berusia muda, mempunyai satu pinjaman, menyewa rumah kediaman, memiliki pelbagai akaun simpanan dan mempunyai tabiat menabung. Kedua, kelompok isi rumah yang mengumpul simpanan (*accumulating savers*)

merupakan individu berusia yang memiliki pelbagai akaun simpanan dan mengumpul aset sehingga tidak memerlukan sebarang hutang. Ketiga, kelompok isi rumah yang boros (*prodigal household*). Keempat, kelompok peminjam yang rapuh (*fragile borrower*). Kajian ini turut mendapati wujudnya perkaitan antara kepenggunaan dan pendapatan terhadap keberhutangan. Kelompok isi rumah yang boros ini didapati memiliki akaun tabungan yang sedikit. Mereka lebih cenderung untuk berbelanja sehingga mencapai tahap kepuasan yang segera dan mementingkan gaya hidup mewah tanpa memikirkan motif pinjaman yang dibuat. Mereka juga mengutamakan pembelian secara pinjaman bagi barangan bersifat domestik meskipun berkeupayaan membeli tanpa membuat pinjaman. Bagi kelompok peminjam rapuh pula, mereka terdiri daripada pasangan yang melakukan pembiayaan pembelian rumah dan perabot secara pinjaman dengan menggunakan harta pemilikan bersama. Kajian ini mendapati tahap keberhutangan golongan ini berada pada skala yang tinggi.

3.0 METODOLOGI

Kajian ini menggunakan pendekatan fenomenologi. Menurut Geertz (1973), penyelidik yang menggunakan pendekatan ini berusaha memasuki dunia konsepsi individu yang diselidiki. Oleh sebab itu, fenomenologi merupakan kajian tentang pengalaman manusia. Ia tertumpu kepada intipati pengalaman peserta dan melibatkan struktur kesedaran seseorang serta tafsiran mereka terhadap suasana di sekeliling mereka (Callagher, 2012). Pendekatan fenomenologi ini bertujuan untuk menjawab pertanyaan mengenai pengalaman sesuatu aktiviti menurut perspektif peserta (Gay dan Mills, 2016).

Seramai tiga orang peserta dalam kalangan pelanggan Agensi Kaunseling dan Pengurusan Kredit (AKPK) yang menyertai Program Pengurusan Hutang (*Debt Management Programme*) (DMP) terlibat dalam kajian ini. Mereka dipilih menerusi kaedah pensampelan bertujuan. Menurut Cresswell (1998) dan Sabitha (2005), seramai 2 hingga 25 peserta diperlukan bagi kajian berbentuk fenomenologi. Anthony dan Nancy (2007) pula berpandangan bahawa kajian berbentuk kualitatif tidak memerlukan jumlah sampel yang besar bagi mengelakkan kesukaran memperoleh data yang padat dan juga tidak terlalu kecil sehingga menyukarkan penyelidik untuk memperoleh tahap data tepu.

Secara lebih terperinci, peserta yang terlibat dalam kajian ini merupakan individu yang hampir bankrap. Menurut pentakrifan oleh Jabatan Insolvensi Malaysia, kebangkrutan individu bermaksud satu proses di mana seorang penghutang itu diisytiharkan sebagai bankrap lanjutan daripada suatu Perintah Penghakiman yang dibuat di Mahkamah Tinggi terhadap penghutang tersebut atas kegagalan atau ketidakupayaan untuk membayar hutang yang berjumlah sekurang-kurangnya RM50,000. Oleh itu, hampir bankrap bermaksud individu berkenaan telah tidak berupaya mengurus pembayaran balik hutang bulanan dengan pihak institusi kewangan dan masih belum diisytiharkan bankrap. Situasi ini menyebabkan individu berkenaan mendapatkan nasihat AKPK dan seterusnya menyertai program pengurusan hutang untuk menyusun semula jumlah pembayaran balik hutang bagi mengelakkan diisytiharkan bankrap. DMP ini dirangka khusus untuk membantu mereka yang mengalami tekanan obligasi kewangan daripada pihak institusi kewangan di bawah pengawasan Bank Negara Malaysia. Menerusi DMP, AKPK dan individu bekerjasama untuk menyediakan penstrukturan pembayaran balik pinjaman individu berkenaan melalui rundingan dengan penyedia kredit dalam kalangan institusi kewangan yang dikawal selia oleh BNM.

Untuk itu, terdapat dua kriteria peserta yang ditetapkan oleh penyelidik. Pertama, individu yang merupakan peserta DMP AKPK. Kedua, individu yang beragama Islam. Bagi kriteria pertama, ia bertujuan untuk memperoleh peserta yang benar-benar mengalami tekanan kewangan. Bagi kriteria kedua, ia bertujuan untuk menganalisis kepatuhan gelagat penggunaan isi rumah peserta berdasarkan gelagat penggunaan menurut Islam. Latar belakang peserta diperincikan seperti Jadual 2.

Jadual 2. Latar Belakang Peserta Kajian

Peserta	A	B	C
Umur	51 tahun	52 tahun	47 tahun
Latar Pendidikan	Ijazah Sarjana dalam bidang perniagaan di universiti awam di Malaysia	Sijil Majlis Latihan Vokasional Kebangsaan	Penilaian Darjah Lima
Pengalaman Kerja	Bekas Pengurus di salah sebuah Syarikat Berkaitan Kerajaan. Hasil pampasan sebanyak RM150,000 setelah memilih VSS dijadikan modal perniagaan. Pernah terlibat dalam perniagaan Multi-Level Marketing (MLM), rumah tumpangan, restoran dan perkhidmatan dobi	Beliau pernah berkhidmat di kilang pembuatan perabot. Beliau berhenti bekerja untuk menjaga ibunya yang sakit di kampung. Sepanjang tempoh berkenaan, beliau hanya bekerja separuh masa dengan menjual air tebu sehingga ibunya meninggal dunia	Beliau berhenti awal dari meneruskan persekolahan sewaktu berumur 11 tahun kerana terpaksa membantu kedua orang tuanya untuk meneruskan kelangsungan hidup
Jumlah Pendapatan	Jumlah pendapatan beliau RM1,500 sebulan. Pendapatan bulanan isi	Anggaran pendapatan bulanan beliau ialah RM1,800 menerusi	Pendapatan bulanan sebanyak RM1,200 hasil daripada kerja

	rumah adalah RM7,000 memandang isterinya penjawat awam	kerja sepenuh masa sebagai pembuat barangan perabot. Kerja mengangkut barangan perabot dan membuat sewaan lori dijadikan kerja separuh masa dengan anggaran pendapatan sebanyak RM2,000 sebulan	separuh masa sebagai pembantu rumah dan penjualan telur serta anak ayam
Jumlah tanggungan	Mempunyai empat orang anak. Perbelanjaan tanggungan anak terpaksa dipikul isteri kerana pendapatannya sekadar menampung keperluan diri, bayaran pinjaman dan modal perniagaan	Mempunyai tanggungan seramai 3 orang anak dan seorang isteri	Beliau kini seorang janda dengan enam orang anak termasuk seorang anak angkat hasil daripada tiga perkahwinan sebelum ini
Latar Hubungan Peserta dengan AKPK	Mendaftar DMP pada tahun 2015 kerana tunggakan bayaran pinjaman peribadi	Mendaftar DMP pada tahun 2017 kerana masalah tunggakan bayaran pinjaman perumahan kali yang kedua yang tidak dibayar selama 4 bulan	Mendaftar DMP pada tahun 2015 setelah mendapat pendedahan daripada promosi yang diadakan oleh AKPK

Nama peserta dirahsiakan bagi menjamin privasi mereka

Temu bual mendalam telah dijalankan ke atas semua peserta secara bersiri yang mencakupi tiga bahagian:

- Bahagian pertama: Temu bual yang memfokuskan sejarah hidup peserta
- Bahagian kedua: Temu bual yang memfokuskan perincian pengalaman peserta
- Bahagian ketiga: Temu bual yang memfokuskan refleksi peserta terhadap makna pengalaman mereka yang telah diberikan dalam kedua-dua sesi temu bual sebelumnya

Dalam masa yang sama, pemerhatian turut serta dilakukan bagi mendapatkan gambaran yang lebih menyeluruh dan melakukan semak imbang bagi setiap dapatan kajian. Terdapat dua hal utama yang menjadi fokus penelitian penyelidik. Pertama ialah deskripsi tekstural yang memfokuskan kepada penyebab tekanan kewangan yang dialami oleh setiap peserta. Apa yang dialami adalah aspek objektif, data yang bersifat fakta dan hal yang terjadi secara empirikal. Kedua ialah deskripsi struktural yang memfokuskan bagaimana peserta mengalami dan merasai pengalamannya. Penerangan ini bersifat subjektif. Aspek ini berkait dengan pendapat, penilaian, perasaan, harapan, serta maklum balas peserta mengenai pengalamannya itu. Pertanyaan yang dikemukakan kepada peserta adalah seperti berikut:

- Apa pengalaman peserta tentang fenomena kesempitan wang sehingga membawa kepada tekanan kewangan?
- Apa perasaan peserta tentang pengalaman tersebut?
- Apa makna yang diperoleh bagi peserta berdasarkan fenomena tersebut?

Dari segi penganalisisan data, terdapat enam prosedur penting dilaksanakan dalam penelitian fenomenologi ini sebagaimana yang dicadangkan oleh Hasbiansyah (2005), Creswell (1998) dan Moustakas (1994). Prosedur pertama, penyelidik menetapkan lingkup fenomena yang akan diteliti. Dalam hal ini, penyelidik berusaha memahami perspektif falsafah di sebalik pendekatan yang digunakan, terutamanya konsep mengenai kajian bagaimana orang mengalami fenomena. Penyelidik menetapkan fenomena yang hendak dikaji menerusi peserta. Prosedur kedua, penyelidik mencatat pertanyaan penelitian yang mengungkapkan makna pengalaman bagi individu yang hampir bankrap, serta meminta mereka memperincikan pengalaman penting setiap harinya. Prosedur ketiga, penyelidik mengumpul data daripada peserta menerusi tiga siri temu bual mendalam. Prosedur keempat, penyelidik menganalisis data. Prosedur ini melibatkan tiga tahap, iaitu tahap awal, tahap *horizontalisation* dan tahap *cluster of meaning*. Dalam tahap awal, penyelidik menerangkan sepenuhnya tekanan kewangan yang dialami oleh peserta. Semua rakaman temu bual mendalam dengan peserta ditranskripsikan ke dalam bentuk tulisan. Dalam tahap *horizontalisation*, penyelidik menginventarisasi pernyataan penting yang relevan dengan topik berdasarkan hasil transkripsi. Pada tahap ini, penyelidik berkemungkinan menunda penilaian. Dalam tahap *cluster of meaning*, penyelidik akan mengklasifikasikan pernyataan yang muncul dalam tahap sebelumnya ke dalam tema, serta mengasingkan pernyataan yang berulang. Pada tahap ini, penyelidik melakukan deskripsi tekstural dan deskripsi struktural. Deskripsi tekstural bermaksud penyelidik mencatat apa yang dialami, iaitu deskripsi tentang apa yang dialami oleh peserta. Deskripsi struktural pula bermaksud penyelidik mencatatkan bagaimana tekanan kewangan yang dialami oleh peserta. Penyelidik juga mencari segala makna yang mungkin berdasarkan refleksi penyelidik sendiri sama ada dalam bentuk pandangan, penilaian, perasaan, harapan peserta tentang penyebab tekanan kewangan. Prosedur kelima, penyelidik membangun deskripsi menyeluruh tentang makna dan esensi pengalaman peserta. Prosedur keenam, penyelidik melaporkan hasil penelitian yang menunjukkan adanya kesatuan makna tunggal dari pengalaman semua peserta.

4.0 DAPATAN DAN ANALISIS

Kajian ini dijalankan untuk menjelaskan punca tekanan kewangan individu yang hampir bankrap menerusi tiga pertanyaan berikut:

- Soalan 1: Apa pengalaman peserta tentang fenomena kesempitan wang sehingga membawa kepada tekanan kewangan?
- Soalan 2: Apa perasaan peserta tentang pengalaman tersebut?
- Soalan 3: Apa makna yang diperoleh bagi peserta berdasarkan fenomena tersebut?

Latar demografi dan pengalaman hidup yang berbeza ternyata telah menghasilkan kepelbagaian punca tekanan kewangan dalam kalangan individu. Ada punca yang berada dalam kawalan individu. Tidak kurang juga punca yang berada di luar kawalan individu. Setiap individu mempunyai keperluan dan kehendak yang pelbagai. Keperluan dan kehendak ini berbeza antara satu sama lain dan boleh berubah dari semasa ke semasa. Sebagai contoh, aksesibiliti internet yang suatu ketika dahulu dianggap sebagai kehendak, kini menjadi keperluan asas. Bukan hanya kepada golongan pekerja, malah golongan pelajar. Lebih-lebih lagi dalam suasana norma baharu yang banyak bergantung kepada kemudahan teknologi. Keperluan inilah yang menimbulkan tekanan dan akhirnya membentuk kepelbagaian gelagat.

4.1 Punca Tekanan Kewangan

Berdasarkan data temu bual mendalam dan pemerhatian turut serta, terdapat empat punca tekanan kewangan dalam kalangan individu yang hampir bankrap. Ia mencakupi (1) polisi ketat pemiutang dan tindak balas emosi, (2) tasawur penggunaan yang tidak tepat dan unsur mistik, (3) perancangan kewangan yang lemah, dan (4) peristiwa luar jangka.

(1) *Polisi Ketat Pemiutang dan Tindak Balas Emosi*

Menjalani kehidupan dalam keadaan kesempitan kewangan tentulah tidak mudah. Lebih-lebih lagi bagi individu yang mempunyai tanggungan. Tidak hairanlah faktor kewangan menjadi punca utama perceraian di Malaysia (Kementerian Pembangunan Wanita, Keluarga dan Masyarakat, 2019). Pelbagai jenis tindak balas emosi muncul seperti tertekan, takut, panik dan marah. Inilah yang dialami oleh semua peserta kajian.

Peserta A: *Stress ni... bank asyik hantar mesej. Bank kacau... Rasa stress sangat. Kita nak bayar tapi dah tak mampu. Rasa tak selasa. Datang perasaan tak selesa. Dengan bank begitulah. Kalau kena masuk penjara, ikutlah.*

Peserta B: *... yang ada pun pihak Bank je lah. Dia orang push saya sehabis-habisnya untuk bayar sampai ugut. Kalau tak bayar dia beri amaran kesannya. Stress juga. Rasa nak buang je telefon ni.*

Peserta C: *... Bank XXX tu menindas kita kan. Anak saya kata "ma, nanti malam ada polis nak mari ambil". Saya kata takpelah kalau polis nak mari ambil pun, redha je lah, nak buat macam mana sebab memang takde duit nak bayar RM3000 serentak. Dia mintak RM3000. Saya dah beritahu saya orang susah, takda duit, sebelum ni kalau masa cik mintak duit banyak mana pun, saya ada banyak mana saya bagi. Katanya semingguni bayar RM150, lepas tu esok lusa telefon lagi minta bayar RM150, Saya ada duit saya bayar. Takde duit tak bayarlah. Memang takde duit. Saya kata kepada dia, Bank XXX ni tolong rakyat ke cekik darah rakyat? Cara ni nampak macam hisap darah rakyat. Memang sakit hati sangat.*

Tindak balas emosi peserta ada kaitan dengan polisi sesetengah institusi perbankan yang kurang menerapkan nilai ihsan dalam proses pengutipan hutang. Sama ada pelanggan berkenaan mengalami kesempitan kewangan atau tidak, pihak bank lebih menitikberatkan prestasi kawalan kredit. Penulis mengakui kenyataan ini berdasarkan pengalaman peribadi sewaktu berkhidmat dengan salah sebuah institusi perbankan di Bahagian Kawalan Kredit.

Situasi ini telah menambah kerisauan para peserta dan akhirnya mengganggu kualiti kehidupan. Dalam kes peserta A misalnya, ada tiga kesan yang timbul akibat tekanan ini, iaitu hubungan kekeluargaan yang tidak harmoni, tekanan kewangan menular kepada isteri dan sumber pendapatan yang semakin berkurangan.

Peserta A: *Kadang datang perasaan menyesal berhenti kerja dulu. Kadang-kadang la. Sebab rasa kesian kat wife.*

Peserta A: *Yang tu biasa lah. Apabila saya sakit, kewangan dah jadi semakin kurang, Lepas tu anak-anak pula semakin perlu duit untuk belanja sekolah. Yelah saya dah tak kerja. Jadi semua kereta atas nama isteri, jadi dia lagi lah tertekan. Lagi tertekan dia.*

Emosi yang terjejas ini tidak berhenti setakat itu. Ia turut memberi kesan kepada pemikiran dan juga kemahiran dalam membuat pertimbangan. Paling dibimbangi, tekanan kewangan ini membawa kepada kemurungan. Kajian Fitch *et al.* (2011) misalnya membuktikan bahawa individu yang tertekan akibat daripada permasalahan hutang berisiko tinggi mengalami kemurungan. Permasalahan ini juga boleh membawa kepada keinginan untuk berhenti kerja (Mohd Ikhwan Aziz *et al.*, 2019). Hasil tinjauan oleh AIA Vitality 2019 ke atas 17,595 pekerja juga mendapati tekanan kewangan amat berpengaruh ke atas masalah kesihatan mental apabila 22% pekerja berada dalam kesempitan kewangan. Tinjauan tahunan itu bertujuan memahami bagaimana tempat kerja dapat mempengaruhi kesihatan pekerja dengan menghubungkan kesihatan pekerja terhadap prestasi dan penglibatan mereka di tempat kerja.

(2) *Ketidaktepatan Tasawur Kepenggunaan dan Unsur Mistik*

Peserta kajian mengakui tekanan kewangan yang dialami berpunca daripada pertimbangan yang kurang rasional semasa membuat keputusan untuk berhutang. Pinjaman bermasalah bagi peserta A misalnya merupakan hutang yang berstatus *tahsiniyat* (penggunaan mewah) untuk memenuhi kehendak. Pinjaman yang diambil ini bukanlah disebabkan oleh desakan kewangan, sebaliknya pengaruh rakan sekerja untuk menikmati taraf hidup yang lebih baik. Beliau berkata begini:

Peserta A: *Tak pernah terfikir, pasal masa tu terfikir nak duit je lah. Kalau sekarang ni saya rasa tak perlu membebaskan diri saya ambil tahu hal tu, mencari pinjaman itu ini. Bagi saya dengan usia saya dan juga hasil wife yang ada tak perlu sangat saya nak ikut nafsu saya lagi dah.*

Peserta A: *Sebab kawan-kawan. Lepas tu keinginan untuk enjoy dengan duit tersebut.*

Pinjaman ini dimanfaatkan untuk tujuan peribadi dan tanggungannya serta dijadikan modal perniagaan yang dijalankan. Pada awalnya, hasil perniagaan yang diperolehi hanyalah pendapatan tambahan isi rumah selain hasil pendapatannya di salah sebuah SBK. Pinjaman yang diperolehinya pula bukanlah patuh syariah. Namun begitu, beliau berpendirian perbuatan berkenaan tidak salah di sisi agama kerana produk tersebut dianggap halal dan tidak membebaskan peminjam. Beliau menyebut begini:

Peserta A: *Halal? Yang tu saya tak fikir pun. Saya tak fikir pun masa saya buat loan tu. Yang penting saya boleh duit RM30,000 tu saya guna je lah. Pastu bayaran takpe, bulanan kan saya potong gaji bulanan kan. Masa tu kita kerja makan gaji. Dengan gaji saya RM6,000-RM7,000, saya rasa kalau potong dalam RM500-RM600 macam tu takde masalah sangat. Tapi tidak expect lah saya akan berhenti kerja.*

Realiti ini mempamerkan tahap literasi kewangan Islam yang rendah bukan hanya peserta A, malah kedua-dua peserta kajian yang lain. Peserta C misalnya tidak mengetahui perbezaan antara kemudahan hutang yang disediakan oleh bank Islamik dan konvensional. Pinjaman beliau yang bermasalah ternyata produk yang tidak patuh syariah. Di samping itu, kesanggupan peserta A untuk berlapar berbanding membayar pinjaman secara penyelesaian penuh memberikan satu petunjuk yang jelas. Kerangka pertimbangan mengenai keutamaan menolak kemudahan berbanding kebaikan sama sekali tidak tepat.

Agak sukar untuk membuktikan secara empirikal perkaitan antara tahap tekanan kewangan dan tahap penghayatan agama. Namun begitu terdapat pelbagai kajian yang menemukan perkaitan ini. Kajian Masjuki Misbah (2017) misalnya menunjukkan wujud hubungan yang signifikan antara tahap pelaksanaan ibadat solat dan kecerdasan emosi. Pelaksanaan ibadat solat yang semakin baik berupaya memperbaiki kecerdasan emosi. Kajian Mohd Suhardi Jusoh (2004) dan Nor Azira Yusoff (2008) juga membuktikan bahawa kecuaiannya melaksanakan ibadat solat berupaya melahirkan kesan negatif kepada seseorang individu. Semua dapatan ini ternyata selari dengan situasi peserta A. Beliau mengakui kelemahannya dalam aspek penghayatan agama. Semasa kedudukan kewangannya masih stabil, beliau kadangkala tidak menyempurnakan bilangan wajib solat fardu terutamanya ketika waktu pejabat beroperasi. Selain daripada jarang mengikuti kuliah agama, beliau juga jarang melakukan solat berjemaah di masjid. Peserta C pula mengakui tidak memberi keutamaan kepada amalan pembacaan al-quran. Beliau menyebut begini:

Peserta C: *Kekerapan membaca Al-Quran? Tak pernah..enam bulan sekali..sebulan sekali..seminggu sekali lah kot.. Bacaan al-Mathurat..hmm.. tak pernah..akak jujur je la ye.*

Penghayatan agama yang ditonjolkan ini ada kaitannya dengan tauhid. Tauhid inilah yang menjadi tunjang kepada segala aspek kehidupan manusia termasuk aktiviti kepenggunaan. Tauhid yang tepat akan membina tasawur yang benar-benar berlandaskan Islam. Tasawur kepenggunaan yang terbit daripada landasan tauhid yang tepat akan mencorakkan satu sistem kepenggunaan yang seimbang antara keperluan kebendaan dan kerohanian (Mohd Shukri Hanapi dan Siti Mastura Muhammad, 2017). Apabila wujud ketidakseimbangan dalam kedua-dua perkara ini, maka timbul perkara lain yang sukar dijelaskan secara saintifik. Ini yang terjadi kepada peserta A yang mendakwa terkena sihir sehingga menjejaskan kesihatan fizikal dan emosinya serta prestasi perniagaannya. Amalan sihir mempunyai unsur mistik, iaitu keadaan ghaib yang tidak dapat diselami oleh pemikiran manusia. Beliau meluahkan begini:

Macam saya la, pengalaman dah ada, duit dah ada, rasa belajar dah tinggi, bukan sekadar SPM, rasa banyak perkara kita boleh buat. Rupa-rupanya kadang-kadang dalam rezeki kita berniaga kita tak ambil tahu perkara yang mistik kadang-kadang tu kita tak ambil kisah. Walaupun kita percaya perkara tu, macam..ahh..takde ape lah sangat pun tapi apabila kita dah lalui..oohh.. gini rupanya. Patut la saya takut nak berniaga walaupun saya dapat masa tu RM1,000 hingga RM2,000 semalaman. Memang saya rasa berbaloi sangat saya berhenti kerja..memang berbaloi..tapi ye lah bila dah kena baru tahu rasa sakit dia tu sampai tak boleh nak buat kerja. Duit pun banyak terpaksa kita keluarkan.

Beliau selanjutnya membuat pengakuan begini:

Pergi berubat kampung je lah. Pernah dah pergi hospital tapi dia orang kata tiada yang abnormal. Pergi pergi tapi tiada apa-apa jugak. Tapi bila berubat kampung begitulah, perkara yang kita tak tahu. Selang dua tiga hari sakit balik, perkara macam tu kan, mistik. Percaya atau tidak percaya begitulah. Saya sebenarnya malas nak bercerita perkara macam ni ke orang, kadang-kadang orang tidak alami ye tidak tahu. Mungkin sebab saya banyak lalai dengan tuhan.

(3) Kelemahan Perancangan Kewangan

Perancangan kewangan yang lemah dan kos sara hidup yang tinggi kekal menjadi dua punca utama tekanan kewangan dalam kalangan individu yang memperoleh perkhidmatan AKPK. Daripada keseluruhan kes AKPK pada tahun 2018, sebanyak 43.3 peratus berpunca daripada perancangan kewangan yang lemah dan kekal sebagai punca utama tekanan kewangan sejak tahun 2013 lagi. Apa yang terjadi kepada semua peserta mengesahkan lagi fakta ini. Pemerhatian turut serta juga mendapati semua peserta kurang memberi perhatian kepada aspek penjimatan utiliti isi rumah, sekali gus meningkatkan aliran keluar tunai isi rumah. Dari segi simpanan, semua peserta tidak memberi keutamaan dalam hal ini. Peserta A misalnya berkata begini:

Peserta A: *Saya utamakan belanja dulu. Belanja dahulu. Lepas tu bayar hutang, lepas baru simpan.*

Kajian ini jelasnya memperlihatkan bahawa semua peserta kajian mengalami masalah kesempitan wang. Baki pendapatan mereka setelah ditolak segala perbelanjaan termasuk komitmen hutang ada kalanya mengalami defisit. Lebih separuh daripada pendapatan mereka digunakan untuk membayar balik pinjaman. Dalam kes peserta A misalnya, beliau membelanjakan lebih separuh daripada hutang isi rumahnya untuk membayar pinjaman perumahan. Realiti ini menunjukkan betapa besarnya pengaruh hutang ke atas pendapatan boleh guna isi rumah. Oleh kerana lebihan yang ada begitu kecil untuk simpanan, kesemua peserta tentunya menghadapi kesukaran untuk melakukan pelaburan.

(4) Peristiwa Luar Jangka

Daripada kesemua peserta, survival peserta C paling mencabar. Perniagaan beliau disabotaj oleh rakan lelakinya yang pernah ditolak lamaran peminangan. Beliau meluahkan begini:

Memang manusia kalau orang berniaga ke apa ke, macam kak dulu, mula-mula 300 ekor, orang sakit hati kan, ada orang letak air chlorox dalam minuman itik a kak bela, mati bergelimpangan itik. Kita dapat tahu bila buat report di jabatan haiwan, kita memang tak putus dengan jabatan haiwan, jadi bila dia orang check dia orang tanya "eh..ada chlorox dalam ni, akak letak chloroxke?" Takkan saya nak letak chlorox. Itik pulak memang tengah bertelur. Telur pulak bukan kecik-kecik. RMI satu biji tu memang besar telur dia. Haa..tapi dia sakit hati. Sakit hatinya kenal lah orang yang sakit hati tu. Kesnya dia datang meminang kak je masa tu. Dia dah ada bini dia datang mai minang kak, kak

kata "eh..mu gila ke wat keje gitu, mu dah ada bini comel dah mu nak buat gini, mu jangan buat keje gila". Lepas tu dia kata "aku kalau tak dapat mu, mu takkan hidup senang". Seminggu lepas tu mati semua itik kak yang 300 ekor tu. Kita sabar je lah bila dah jadi gitu. Kita tunggu 6 bulan nak ke dapatkan hasil tu. Dari sini pergi ambil perut ikan di Kuala Kemaman setiap petang. Balik rebus lagi pakai dapur kayu. Bau busuk setiap hari kata orang memang tak bau wangi, lepas tu balik maghrib rebus bagi makan itik. Tapi bila dah kena gitu, kita... "hmmm..takpelah, bukan rezeki kita". Kali kedua 800 ekor, yang tu memang sayang.

Dalam masa yang sama, beliau masih mendapat ancaman daripada bekas suami yang masih berada dalam penjara. Beliau membuat pengakuan begini:

Laki tu pun kan mental. Daripada hospital Kuala Berang hantar ke Hospital Bahagia Tampoi sebulan, sekarang ni dah balik tu. Ada dalam penjara la tu sekarang ni. Bila akak cakap dengan polis, dia orang kata laki tu akan keluar jugak nanti. Dan polis tu kata kalau ye nak ambil anak dia tu boleh je. Ni bukan soal nak ambil anak dia je, masalahnya dia tu ganas dengan anak. Sebab tu akak letak grill di pintu tu. Takut jugak la rasa. Apa-apa kunci terus pintukan. Lagi-lagi pintu yang asal ni pun senang lompat. Untuk keselamatan budak-budak ni la jugak buat tu. Sebab yang duduk rumah ni semua perempuan bila akak tinggal pergi kerja. So bila ada grill ni apa-apa hal mudah nak kunci kemas-kemas duduk dalam rumah.

Selain itu, beliau juga ditimpa masalah saraf yang memerlukan perbelanjaan yang besar, sekali gus mengurangkan jumlah simpanannya. Ketiga-tiga masalah ini merupakan peristiwa di luar jangka yang memerlukan solusi yang radikal demi survival kewangan.

5.0 PERBINCANGAN DAN KESIMPULAN

Telah dibuktikan bahawa wujud punca lain yang lebih utama berbanding kelemahan perancangan kewangan yang selama ini dianggap sebagai punca utama tekanan kewangan. Ketidaktepatan tasawur kepenggunaan ternyata lebih besar pengaruhnya berbanding kelemahan perancangan kewangan. Tasawur yang tidak tepat akan melahirkan asas pengukuran yang menyimpang dari matlamat sebenar kepenggunaan. Sebagai contoh, kejayaan seseorang lazimnya diukur menerusi pemilikan harta benda. Unsur kebendaan seperti rumah besar, kereta mewah dan perhiasan eksklusif biasanya ditonjolkan sebagai ukuran kejayaan seseorang. Kenyataan ini tidak bermaksud Islam menghalang pengembangan harta benda sebagaimana yang dirakamkan menerusi surah al-Maidah ayat 87 yang bermaksud: *Wahai orang-orang yang beriman, janganlah kamu haramkan apa-apa yang baik yang telah Allah halalkan kepada kamu dan janganlah kamu melampaui batas.* Pengembangan harta benda dibenarkan selagi mana ia diperoleh dan diagihkan dengan cara yang betul (*makarim al-akhlaq*). Dalam masa yang sama, ia mesti menghindari gaya hidup yang berlebihan dan melampaui batas (*mahasin al-adat*). Gaya hidup sebegini yang membawa kepada pembaziran dan pemborosan harta (al-Shatibi, 1997). Tanpa menafikan keharusan penggunaan bersatus kemewahan, unsur kekayaan jiwa tidak boleh dikesampingkan dalam sesuatu pengukuran.

Tasawur kepenggunaan yang ditimbulkan ini ada kaitan dengan salah satu daripada tujuh prinsip pembangunan berteraskan Islam yang diperkenalkan oleh Muhammad Syukri Salleh (2003), iaitu manusia sebagai pelaku pembangunan. Oleh sebab manusia diiktiraf sebagai khalifah, bukannya haiwan ekonomi (*homo-economus*), pengukur kepada kekhalifahan adalah iman dan nafsu. Iman dan nafsu pelaku mestilah didorong untuk paling tidak berada pada tahap iman *ayan* dan nafsu *mutmainnah* masing-masing. Tidak mungkin gelagat penggunaan dapat diperkasakan dari semasa ke semasa jika pelaku memiliki iman di bawah daripada iman *ayan* misalnya iman *taqlid* dan iman *ilmu* sahaja. Samalah juga seperti nafsu. Pelaku yang memiliki nafsu di bawah daripada nafsu *mutmainnah* seperti nafsu *ammarah*, *lawwamah* dan *mulhamah* tentunya berdepan dengan kesukaran untuk memperkasakan gelagat penggunaan dari semasa ke semasa.

Sekiranya dihubungkan prinsip di atas dengan pengalaman hidup peserta kajian, ia menjelaskan tiga perkara. Pertama, asas paling utama dalam sebarang aktiviti penggunaan adalah pengurusan iman dan nafsu. Kajian ini jelas membuktikan bahawa pengetahuan dan kesedaran yang tinggi tentang penyediaan perancangan kewangan bukanlah jaminan seseorang itu bebas dari tekanan kewangan. Pengetahuan yang terhad tentang perancangan kewangan juga tidak semestinya membawa kepada kesempitan kewangan. Realiti ini yang terjadi kepada sebilangan generasi *baby boomers*. Dengan pendedahan yang begitu terhad tentang ilmu pengurusan kewangan, tidak pula kelihatan mereka mengalami kesempitan kewangan. Jarang sekali ditemui mereka menyediakan bajet isi rumah menerusi catatan aliran tunai masuk dan keluar secara berkala. Biarpun begitu mereka masih dapat memenuhi keperluan diri sendiri dan tanggungan. Lebih pelik lagi, mereka kekal melaksanakan amalan berinfak. Situasi ini diyakini ada kaitan dengan tasawur yang betul menurut perspektif agama. Unsur seperti keberkatan

dalam rezeki membolehkan mereka merasa cukup dengan setiap perolehan. Berbeza dengan realiti masyarakat masa kini yang berdepan dengan krisis moral dalam sistem ekonomi. Perasaan tamak haloba, kedekut, kikir dan sebagainya ternyata merosakkan kesejahteraan individu, keluarga dan masyarakat. Pembaziran makanan pada bulan Ramadan misalnya menjadi contoh kelemahan pengurusan iman dan nafsu. Jumlah penggunaan yang sepatutnya berkurang kerana aktiviti berpuasa, sebaliknya memperlihatkan pertambahan tan metrik sampah di sepanjang bulan Ramadan.

Kedua, perancangan kewangan diakui menjadi keperluan kepada survival kewangan isi rumah. Tambahan pula dalam suasana pandemik yang memperlihatkan kemunculan pelbagai bentuk keperluan dan kehendak dalam norma baharu. Kegagalan merancang kewangan lazimnya memberi kesan kepada pengurusan perbelanjaan, pelaburan untuk diri sendiri dan tanggungan, dan persediaan masa depan. Corak perbelanjaan peserta kajian jelas memperlihatkan kelemahan yang ketara dalam aspek perancangan kewangan. Dalam hal ini, survival kewangan mereka bergantung sepenuhnya kepada pendapatan bulanan. Mereka juga terpaksa bergantung kepada kerja sampingan, kerja lebih masa, komisen atau bonus untuk membiayai kos sara hidup harian. Ada dalam kalangan mereka yang tidak mengambil tahu tentang jumlah hutang sebenar sehinggalah menerima sesuatu penyata. Selain itu, corak perbelanjaan yang menyebabkan tiadanya lebih pendapatan boleh guna diakui mengganggu keharmonian rumah tangga. Walau bagaimanapun perancangan kewangan semata-mata tanpa disandarkan kepada tasawur Islam sekadar melahirkan seseorang yang terlalu berkira dalam aktiviti filantropi sama ada dalam bentuk zakat, wakaf dan derma. Hujah yang ditimbulkan oleh salah seorang peserta kajian adalah kebimbangan berkurangnya jumlah pendapatan boleh guna berikutan peningkatan aliran keluar tunai menerusi aktiviti filantropi. Walhal Baginda Rasulullah s.a.w. pernah bersabda: *Harta tidak akan berkurang kerana sedekah* (diriwayatkan oleh Muslim, hadis no. 4689).

Ketiga, tasawur kepenggunaan yang tidak tepat telah menyebabkan ketidakseimbangan antara keperluan jasmani dan rohani. Pengakuan peserta yang terlalu memberi tumpuan kepada usaha menambah pendapatan isi rumah sehingga mengabaikan solat ternyata telah membawa kepada tiadanya ketenangan hati. Lebih mengejutkan, keadaan ini melahirkan pula unsur mistik sebagai punca yang jarang ditemui dalam kajian terdahulu. Penemuan baharu ini memperkayakan lagi pemahaman tentang peristiwa di luar jangka sebagai punca tekanan kewangan. Pengalaman disihir tidak hanya memudaratkan kesihatan fizikal, bahkan memberi kesan negatif kepada emosi peserta dan pasangannya. Penemuan ini menjelaskan bahawa insiden kesempitan kewangan tidak hanya berpunca daripada faktor yang boleh dikawal seperti lemahnya perancangan kewangan, malah faktor di luar kawalan seperti terkena sihir.

Ketiga-tiga perkara ini ternyata menjawab persoalan tentang mengapa terjadinya tekanan kewangan peribadi. Ia mempamerkan betapa perlunya menilai semula aspek pembudayaan gaya hidup yang lestari dalam kalangan isi rumah di Malaysia. Ia mengambil kira gaya hidup semasa dalam kalangan Muslim yang boleh digambarkan dalam empat kuadran seperti paparan Rajah 2.

Tasawur

Kuadran 1 Tasawur penggunaan tepat tetapi lemah perancangan kewangan	Kuadran 4 Tasawur penggunaan tepat dan baik perancangan kewangan
Kuadran 2 Tasawur penggunaan tidak tepat dan lemah perancangan kewangan	Kuadran 3 Tasawur penggunaan tidak tepat tetapi baik perancangan kewangan

Perancangan Kewangan

Rajah 2: Matrik Literasi Kewangan Berteraskan Islam

Dalam kuadran pertama, tasawur penggunaan yang tepat menurut Islam tanpa perancangan kewangan yang teliti masih berupaya mengekalkan kecukupan diri dan tanggungan terutamanya keperluan asas. Dalam kuadran kedua, kelemahan dalam aspek tasawur dan perancangan kewangan memberi kesan buruk bukan hanya kepada dirinya malah keluarga dan masyarakat. Survival kewangan kumpulan ini tidak boleh bertahan lama dan berpotensi untuk meningkatkan insiden kemiskinan harta benda dan kemiskinan jiwa. Dalam kuadran ketiga, perancangan kewangan yang teliti tanpa tasawur penggunaan yang tepat diakui masih berupaya memberi kesejahteraan hidup. Walau bagaimanapun, manfaatnya hanya terhad kepada kemaslahatan diri sendiri dan tanggungannya. Masyarakat sukar memanfaatkan kelebihan sumber yang ada pada dirinya. Dalam kuadran keempat, kekuatan yang ada dalam aspek tasawur dan perancangan kewangan inilah yang membentuk gaya hidup yang lestari. Kelebihan sumber yang ada pada dirinya turut dinikmati oleh golongan yang kurang bertasib baik, sekali gus menjadikan dirinya sebaik-baik manusia. Inilah yang dirakamkan menerusi hadis Nabi yang bermaksud: *Sebaik-baik manusia adalah yang paling bermanfaat bagi manusia* (Diriwayatkan oleh Ahmad, ath-Thabrani, ad-Daruqutni dalam Shahihul Jami' no: 3289).

Usaha membudayakan kuadran keempat inilah yang perlu digerakkan sejak dari peringkat pengajian rendah lagi dengan menambah baik kurikulum pendidikan Islam dan memasukkan elemen kepenggunaan Islam dalam kandungan kursus atau subjek. Begitu juga dengan pemeraksanaan aktiviti pengajaran dan pembelajaran sedia ada agar lebih interaktif untuk memberikan kefahaman tentang falsafah penggunaan yang betul di sisi Islam. Dengan demikian, anak-anak kecil sudah ditanam dan dipupuk dengan tasawur sebenar menurut Islam yang berintikan nilai keredaan Allah s.w.t, bukannya tasawur barat yang berintikan nilai kebendaan. Andainya ini dapat dilaksanakan, gaya hidup lestari yang sarat dengan nilai kemanusiaan dapat dibudayakan dalam norma baharu.

PENGHARGAAN

Kajian ini dibiayai oleh Universiti Sultan Zainal Abidin (UniSZA) menerusi geran translasional universiti UniSZA/TUG/2019/02. Setinggi-tinggi penghargaan kepada Agensi Kaunseling dan Pengurusan Kredit (AKPK) di atas segala sokongan dan bantuan untuk melengkapkan kajian ini.

RUJUKAN

- Ahmad Azrin Adnan (2012). Gelagat pengguna Islam: Satu disiplin atau sub-disiplin? (Islamic consumer behavior: A discipline or sub-discipline?). *Jurnal Pengurusan*, 35, 139-149.
- Ahmad Azrin Adnan, Mohd Izzuddin Abdul Aziz, Sakinah Mat Zin & Wan Anisah Endut (2018). A redefinition of the productive debt concept in halal lifestyle framework. *International Journal of Academic Research in Business and Social Sciences*, 8(6), 553-565.
- Agarwal, S., & Mazumder, B. (2013). Cognitive abilities and household financial decision making. *American Economic Journal: Applied Economics*, 5(1), 193-207.
- Agensi Kaunseling dan Pengurusan Kredit (2018). *Financial behaviour and state of financial well-being of Malaysian working adult*. AKPK.
- Anita, W. (2014). *Educational psychology*. New Jersey: Pearson New International Edition.
- Bank Negara Malaysia (2018). Laporan Tahunan. BNM.
- Brown, S., & Taylor, K. (2014). Household finances and the "Big Five" personality traits. *Journal of Economic Psychology*, 45, 197-212.
- Cuvillier, R. (1979). The housewife: An unjustified financial burden on the community. *Journal of Social Policy*, 8(1), 1-26.
- Donnellan, M. B., Conger, K. J., McAdams, K. K., & Neppl, T. K. (2009). Personal characteristics and resilience to economic hardship and its consequences: Conceptual issues and empirical illustrations. *Journal of Personality*, 77(6), 1645-1676.
- Financial Education Network (2019). Malaysia: Strategi Literasi Kewangan Kebangsaan 2019-2023. FEN.
- Gallagher, S. (2012). *Phenomenology*. New York: Palgrave Macmillan.
- Gay, L. R. & Mills, G. E. (2016). *Educational research: Competencies for analysis and applications*, New Jersey: Pearson.
- Gordon, B., Paul, L. & Jack, G. (1986). Farm crisis: Patterns and impacts of financial distress among IOWA farm families. *Rural Sociology*, 51(4), 436.
- Letkiewicz, J. C., & Fox, J. J. (2014). Conscientiousness, financial literacy, and asset accumulation of young adults. *Journal of Consumer Affairs*, 48(2), 274-300.
- Mohd Ikwan Aziz, Suchi Hassan, Ahmad Azrin Adnan & Wan Hasannudiin Khairy (2019). An empirical investigation into Malay workers' intentions to leave their jobs. *International Journal of Innovation, Creativity and Change*, 7(10), 57-75.
- Newacheck, P. W. & Halón, N. (1986). The financial burden of medical care expenses for children. *Medical Care*, 24(12), 1110-1117.
- Pusat Penyelidikan Kesejahteraan Sosial Universiti Malaya (2018). Laporan Kaji Selidik Tekanan Kewangan. SWRC.
- Servon, L. J. & Kaestner, R. (2008). Consumer financial literacy and the impact of online banking on the financial behavior of lower-income bank customers. *The Journal of Consumer Affairs*, 42(2), 271-305.
- Yao, R., and Xu, Y. (2015). Chinese urban households' security market participation: Does investment knowledge and having a long-term plan help? *Journal of Family and Economic Issues*, 36(3), 328-339.

AN INVESTIGATION INTO THE DEVELOPMENT OF FAMILY WAQF AND FAMILY BUSINESS WAQF IN MALAYSIA

Mohar Yusof^a, Mohd Yaziz Mohd Isa^b, Leilanie Mohd Nor^c

^{ab}Bank Rakyat School of Business and Entrepreneurship
Universiti Tun Abdul Razak
^cBinaPavo @ kCommerce (M) Sdn Bhd

ABSTRACT

This exploratory study investigates the development of family waqf and family business waqf in Malaysia by examining case studies of family foundations supporting and undertaking philanthropic and charitable activities in areas of research and education. The investigation is to uncover the role of affluent Muslim business families in contributing to socio-economic development of the society and community through the foundations that they have built for nurturing and sustaining family legacy. Case study approach is used to undertake an in-depth assessment of the mentioned role, waqf structures and activities. This research aims to discover a sustainable model for family waqf management that can be adopted and implemented by affluent Muslim business families.

Key words: Waqf Management, Family Waqf, Family Business Waqf, Sustainable Model, Philanthropy

1.0 INTRODUCTION

Historically, waqf played a key role in the development of Muslim societies. Waqf served the Muslim community (ummah) in almost all fields, such as religion, education, medicine and other socio-economic activities. However, waqf has become dormant and less popular in Muslim countries. Waqf no longer serves the needs of the ummah due to problems, such as mismanagement, waqf laws and awareness of it in Muslim society (Haji Mohiddin, 2015).

Further, Haji Mohiddin reiterated that the status of waqf has deteriorated to such an extent that in some countries waqf assets have been neglected and abandoned. He attributed this issue to colonialism whereby countries like Malaysia and Singapore adopted western laws, which precede Islamic laws including those dealing with waqf. Despite this, he believed that the state of Johor and Singapore still provide the best models of the successful development of waqf.

This study is not aimed at investigating issues directly connected to state or government administration of waqf assets. Nevertheless, state or government administration may be indirectly related to family waqf and family business waqf management. In the context of family waqf and family business waqf management, the state and government is an external stakeholder as institutionally the form or structure of the family waqf or family business waqf has to comply with existing and related laws enacted by the state and government.

The motivation of this exploratory study is primarily to investigate the development of waqf in the context of Muslim families in business and Muslim families of wealth. Specifically, case studies of two Muslim families undertaking philanthropic and charitable activities in areas of research and education are analysed.

The investigation is to uncover the role of these affluent Muslim business families in contributing to socio-economic development of the society and community through the foundations that they have built for nurturing and sustaining family legacy. Nevertheless, the aim of this study is to conceptualise the priori constructs of sustainable family waqf management in order to achieve greater efficiency of its social economic objectives.

2.0 LITERATURE REVIEW

According to the Webster's dictionary, family is defined as "a group consisting of parents and children living together in a household". This definition is a starting point because the term family can be extended and viewed differently by any person because the word may conjure-up multiple different meanings and emotions.

Whereas a family business can be simply be defined as a family, collectively, owning a business. Mohd Nor (2013) and Yusof (2020) described several key elements influencing the definition of family business. The key elements

with different types of family business definition includes majority ownership, management involvement ownership and management, succession intentions and family members who define the business. Further, there must be at least two generations are involved in the business where at least, one child of the founder is involved in the running of the business.

The majority ownership is defined where a family can easily control a business with less than 50% of the votes if the ownership structure is fragmented. Families can own 100% of their companies and they can make all the major decisions, although some non-family member is the CEO of the company specifies the management involvement. The ownership and management defined by a certain portion of the business; and holding a management position within the business. The owner has the intention to transfer the business to the next generation meets the succession intention element. Very importantly also, family members would have the opportunity to state their opinions about the family business.

Two elements that seem to be important in family business are the intention to transfer the business to the next generation, and the statement by owners and managers that they themselves perceive the business as a family business. In the same vein, we believe the intention to benefit or towards good deeds benefitting others is accepted by Allah so long it is for permitted charitable causes.

Any act of philanthropy or charitable endowments can be regarded as waqf because in principle, there are 4 elements for a waqf to come into being:

- The donor (*waqif*) who has legal right ownership over the property
- The waqf property or wealth (*mawquf*) or usufruct of the property
- The beneficiaries (*mawqufalaih*) can either be muslims or non-muslims, rich or poor
- The declaration of waqf (*siqah*)

Majority of Muslim scholars hold the opinion that “once a waqf, always a waqf” and such waqf may not be revoked and the waqf property cannot be sold or made the subject of a gift or inheritance. Haji Mohiddin (2015) in comparatively studying waqf development in Malaysia and Singapore postulated that waqf or endowment as an institution begins with a pious intention to do good deeds for the benefit of one and others.

Waqf is a dedication made by one person for the benefit of others, with the intention that the dedicator be entitled to a continuous reward from Allah the Creator throughout the period of the endowment. Once the waqf is declared by the person it will effect a transfer of the property which is the subject matter of the dedication to Allah Almighty. However, the benefit derived from the use of property will be given in accordance with the founder’s intention (Haji Mohiddin, 2015).

Another important element is that the principal component or *corpus* of the waqf should not be used or diminished in its form, condition nor value. Instead, the usufruct, outputs or benefits from the property can be used for pious purposes. The waqf must be administered by a trustee or mutawalli (waqf administrator), appointed by the waqif or in countries like Malaysia where there is law on waqf, the mutawalli is appointed by the State Islamic Religious Council.

In the case of Malaysia, the State Religious Council functions as Nazir which main role is to ensure that the waqf property is used in accordance to the intent, purpose, and declaration of the waqif. Many of us do not understand the role and responsibility of the Nazir. In fact, the responsibility of maintaining and developing the waqf property rests on the Muslim community in the State where the waqf is registered, and this is referred to waqf am for the benefits of the public.

In the context of waqf, trust, endowment and foundation that is prevalent in Muslim families in business and Muslim families of wealth, principally, waqf, trust, endowment and foundation are established traditions in human history reflecting the means by which family donors’ or settlers’ natural inclinations to donate and care for other family members.

In the case of *waqf* (an Islamic endowment) it is formed in expressed compliance with *shariah*; but not for the other secular types of endowments, foundations or trusts. Researchers have not disputed the practice of waqf predated the birth of trust in English jurisprudence, according to Abdullah (2019).

Also, waqf is usually perpetual and central to its formation, is for charitable purposes. It has socio-economic implications as a property-conveyance tool just as trust, though in the case of trust, the property disposition and

wealth management are more dominant over the charitable spirit (Abdullah, 2019). Under the broad umbrella of waqf, *Al-waqf Al Ahli* or the family waqf is one important type of waqf.

In addition, these inclinations of charity and fostering well-being by family donor (*waqif*) to donate, trusting and caring specifically for other family members and beneficiaries, to support and help them, are strongly rooted and influenced by religious values and traditions. The concept and vehicle of waqf has roots in Muslim civilisation. To resemble in some aspects of charitable waqf (*al-waqf al-khayri*), *al-waqf al-ahli* or the family waqf however is dedicated and trusted specifically for described family members and relatives.

Today, in the context of sustaining family or family business legacy, vehicles such as family foundation, family trust, family association, endowment in the name of the family, etc. are used. In the context of family or family business waqf, the beneficiaries are specified family members, relatives and descendants of the waqf, and other specific relatives as specified by the waqf.

3.0 THEORETICAL PROPOSITION: PRIORI CONSTRUCTS

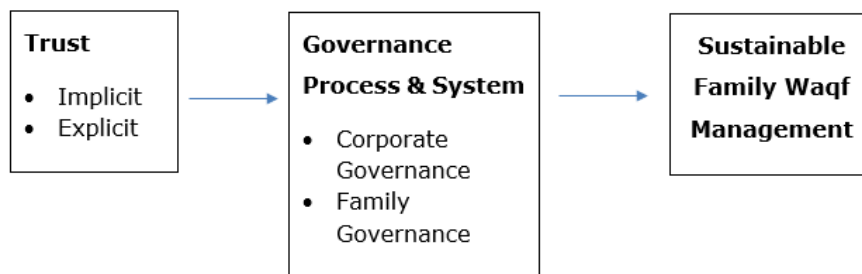

Figure 1: Focal Constructs

The following research questions are formulated to guide this study:

- How does trust (implicit and/or explicit) affect governance process and system and lead towards sustainable family waqf management in research and education?
- How do governance process and system (corporate governance and/or family governance) lead to sustainable family waqf management in research and education?

4.0 CASE STUDY METHODOLOGY

The following sections describe the family waqf management process in two Muslim families in business and families of wealth. Qualitative evidence was collected through in-depth interviews, informal conversations and personal observation (Yin, 1994). The interviews were then integrated with secondary source data, such as available company documents, family information, and other available information pertinent to the firm and corporate social responsibility as well as its family governance, charity, philanthropy and wealth management process and structures (Eisenhardt & Graebner, 2007; De Massis & Kotlar, 2014).

These sources were used to verify the interview data and ensure objectivity in the data collection process. The use of multiple sources of data allowed the triangulation of evidences (Yin, 1994) and ensured that our research followed established data collection practices and contributes to the long tradition in management research to advance theory building based on case study approach (Eisenhardt & Graebner, 2007; De Massis & Kotlar, 2014).

5.0 THE FAMILY BUSINESS GROUPS AND THEIR PHILANTHROPIC ACTIVITIES

5.1 Case 1

This private Muslim family business group has been around for more than 40 years and founded on sibling partnerships comprising of the main founder who holds majority stake in the business group and his elder brother and a close cousin who is treated like a brother. Throughout its growing years, particularly in the past 25 years, they have brought in their second generation who are their children, nieces and nephews into the business. Presently, there are more than ten second generation family members who are working in the business holding various positions at the senior, middle and low levels of management. The business group is one of the largest media group in Malaysia and has reached annual revenues of RM400 million (average).

They were very involved and passionate about corporate social responsibility (CSR). We have done significant

research, conduct presentations, write case studies and published papers (around ten years) on family values, management succession, transgenerational entrepreneurship, decision making process in new venture creation, virtuous ethics and CSR implemented by this family business group (Mohd Nor, 2014; Mohd Nor & Yusof, 2014; Yusof, Mohd Nor & Hoopes, 2014; Hoopes, Mohd Nor & Yusof, 2018). In addition to the various and continuous CSR programs and activities, the family has incorporated two foundations. A foundation was incorporated under the Trustee (Incorporation) Act 1952 and the other foundation is formed as a non-governmental organisation.

The former highlights the spirit of the Nuzul Qur'an, so that the Qur'an is read, understood and practiced. The foundation advocates that the Quran provides management tips and all sorts of answers to whoever is willing to learn. By having the Qur'an in our hearts, the Muslim people will have good hearts and strong characters and able to lead their organisations towards success in this world and the hereafter.

Meanwhile, the latter foundation provides hope to single mothers who are raising the families independently. Its activities advocate for the rights of single mothers and to raise public awareness on the importance of raising better families for the nation's future. In carrying out this community responsibility, the foundation intends to alleviate the burden faced by single mothers.

In addition, the family business group established an education fund sixteen years ago to assist SPM, STPM and Diploma students to pursue higher tertiary education. The program started by offering scholarships to staff members and later extended to not only staff members and their families but the public as well. This financial assistance has benefited more than 500 students who have graduated in various fields of study from around nine higher education institutions.

5.2 Case 2

This refers to a public listed Muslim family business group involved in the business of financial services, property development, property management, engineering, information technology, and, consumer goods and services. It is reported that the investment holding company has total assets exceeding RM6.3 billion and is controlled by a prominent and successful entrepreneur who is the company's Executive Chairman. The parent company was incorporated in 1910 and thus it has reached 110 years old. The company and Executive Chairman have formed six charitable foundations and founded a Family Labuan Foundation and a Charitable Labuan Foundation. His children are involved in the business group and family foundations.

A report on one of the foundations formed under the family business group is available on the company's website. Based on this report, the foundation was established in 1991 to focus primarily on sustainability in the fields of education, welfare of the hardcore poor and alleviation of human suffering.

Several reported charitable activities included:

- Donation RM30 million for an endowment fund to provide scholarships to local university's undergraduates;
- Endowed a building valued at RM25 million to a local university to serve the needs of postgraduate students in a particular faculty.
- Donated £2.9 million to establish a fellowship programme at an international centre of excellence. The fellowship is awarded to scholars studying any aspect of the contemporary Muslim societies;
- Financed the construction of an art gallery and auditorium at a local university in the amount of RM15 million;
- Donated RM10 million for the construction of a sports arena and RM5.52 million for an endowment fund to provide scholarship to students at a local university;
- To a particular local university, donated RM7 million for the construction of a multipurpose complex and rental proceeds are used to provide scholarship to poor students who excel in their studies, and, donated RM5 million for a perpetual endowment property fund to provide scholarship and research grants;
- Donated RM10 million to a local private Education Council of secondary schools to support nation building through education;
- Donated RM4.2 million to a local and premier boarding secondary school to construct a sports arena;
- Donated RM3 million to a local secondary school to construct a duplex library building;
- Donated RM1 million to a local university for an endowed Chair in E-Learning to strengthen the university's research and teaching in the field;
- Many other donations and endowment for scholarship, development of sports, construction of Muslim burial sites, mosques, surau makeover, rebuilding homes for flood victims, learning for refugees, etc.

6.0 ELEMENTS OF TRUST AND GOVERNANCE

In analysing the two cases, we investigated and induced whether the existence of trust (implicit and explicit) can directly or indirectly influence the establishment and implementation of corporate governance and/or family governance processes and systems.

In explaining trust in its implicit form, Mohd Nor et. al. (2015) reiterated that trust can be understood as the expectation that the other actor in a dyad will not exploit one's vulnerabilities and that the overall outcome of a relation will benefit both parties. "Reduced to its basics, trust involves a belief that the other person will be honest. Trust is warranted if the belief is true" (Casson & Cox, 1997: 179).

Generally, there is the assumption that family firms are particularly built on trust (Corbetta & Salvato 2004). In a family setting where by definition the family members have strong social ties, trust in the next generation involves both a personal and a competence component. On the interpersonal side, if trust will be warranted to the children, it will be stronger than for outsiders; the same might apply to distrust, i.e. there might be a tendency to judge trustworthiness at the extremes (both positive and negative) (Mohd Nor et. al., 2015).

In its explicit form, Silivarajoo (2018) described that a trust is an agreement between two parties, the settlor and the trustee(s), which permits the separation of legal ownership and beneficial interest: the trustees become the owners of the trust property as far as third parties are concerned, and the beneficiaries are entitled to expect that the trustees will manage the trust property for their benefits.

Further, the law makers and enforcers in Malaysia regard a charitable foundation as a non-profit organisation (NPO). A NPO can be incorporated either as:

- a) a charitable corporation (company limited by guarantee) under the Companies Act 2016 [Act 777] overseen by the Companies Commission of Malaysia;
- b) a constitutional basis registered society or association under the Societies Act 1966 [Act 335] supervised by Registrar of Societies;
- c) an incorporation of trustees by founder or associations of person or body corporate governed by the Trustees Incorporation Act 1952 [Act 258] overseen by the Legal Affairs Division (BHEUU) of the Prime Minister's Department;
- d) a Labuan Trust Company or Labuan Foundation under the Labuan Trusts Act 1996 [Act 554] and Labuan Foundation Act 2010 [Act 706] regulated by the Labuan Financial Services Authority (Labuan FSA).

In the Malaysian Code of Corporate Governance, the Securities Commission Malaysia defined corporate governance as the process and structure used to direct and manage the business and affairs of the company towards promoting business prosperity and corporate accountability with the ultimate objective of realising long-term shareholder value while taking into account the interest of other stakeholders.

On the other hand, Family Business Consulting Group, Chicago, USA, describes family governance as a process or structure to educate and facilitate communication between family members. It also provides a forum for constructive discussion, problem solving and decisions about the family as it relates to the business, as well as, how the business relates to the family.

We observe that in the case of family waqf and family business waqf, a charitable foundation can be used as a governance structure for the trust deed to be operationalised. A registered foundation becomes a legal entity, gets its own legal personality, to fully, efficiently and effectively manage the assets it owns.

Case 1 family business group has chosen the charitable corporation and an incorporation of trustees to form its charitable foundations whereby Case 2 family business group has selected an incorporation of trustees and Labuan Foundation to form its corporate charitable foundations and family foundations.

Table 1: Evaluation of Trust and Governance

Case	Implicit Trust	Explicit Trust	Corporate Governance	Family Governance
1	+ (high)	+ (moderate)	+ (formal)	- (informal)
2	+ (moderate)	+ (high)	+ (formal)	+ (formal)

Based on the case study analysis and qualitative strategies we pursued, we found that Case 1 family business group actively involved its family members (founding and second generations) not just in its business activities but also in its charitable and philanthropic activities. The founders have inculcated family traditions and values which were

effectively communicated and practiced in their business entities thereby these deeds and habits have become virtues and demonstrated in the CSR activities organised by the family business group and its charitable foundations.

Further, we observed that implicit trust is high not only among family members but also among its employees. It is possible that because of high implicit trust, explicit trust exists but at a moderate level. Further, the family business group has concentrated more on building corporate governance rather than family governance. Family governance process and structure seem not available explicitly but informally. It is observed that the founders feel having an explicit and robust family governance is not a priority since they have built a strong corporate governance process and structures.

However, in Case 2, we witnessed some conflicts and lack of implicit trust between family members, between parents and their children as well as between siblings (second generation family members). We noticed that in pictures taken and presented related to the charitable foundation and its philanthropic activities, the focus and highlight was on the founder and in only a few instances, the next generation successor was visible but not her siblings. Hence, we induced that there is a moderate level of implicit trust which may have required the high level of explicit trust.

Being a public investment holding group directly requires the compliance and adherence to good, ethical conduct and corporate governance. The first and third authors were involved in the initial development of the family governance process and structure for this affluent family and confirmed that formalisation of family governance structure had taken place. However, we are unable to verify whether the family governance process and structure has efficiently and effectively governed the family as how the founder envisioned.

7.0 SUSTAINABLE FAMILY WAQF MANAGEMENT

In this aspect, we believe that a sustainable model for family waqf management requires not only the aptitude in managing waqf according to the law and spirit of the *shariah* and Allah's revelation but also the sophistication and professionalism to ensure sustainability of the entity and governance structure used to manage the family waqf or family business waqf.

We discerned that in both case studies, the source of wealth utilised for the philanthropic and charitable activities was deployed from the family business groups' profits. We are uncertain and have yet to determine: how the assets under management by the charitable foundations are being managed sustainably and whether the assets are reinvested to generate returns for future activities and well-being of the beneficiaries? how the funds and endowments given to research and educational institutions are being managed? Are the principal amount of endowments and funds for research and education reinvested by the receiving institutions and only the dividends and/or profits used or the principal amounts are spent as expenses?

8.0 PILLARS OF SUSTAINABLE FAMILY WAQF MANAGEMENT

Even though the legal and governance structures mentioned in the preceding sections are not required to be reported and registered with the relevant State Islamic Religious Authority (SIRC) as they have complied to existing and relevant laws set by the Federal government, are these family waqf and family business waqf structures acceptable and acknowledged by religious scholars and authorities? This is because in Malaysia, matters related to the religion of Islam, as in the case of waqf, are considered to be the realm of SIRC. As we are aware, there are still challenges of having a uniformed and standard set of Islamic laws across all states in the country.

There are still many cases of family waqf that are not reported and registered with the relevant State Islamic Religious Authority (SIRC). For instance, drawing from the first author's own experience on his father's side, where his great grandfather who was a religious scholar had trusted and dedicated a piece of land specifically as burial ground for use by his bloodline i.e. family members and future heirs and descendants. Currently, the trusted trustee is his father's uncle (the youngest of my grandfather's siblings). His great grandfather, the waqif, then specifically disclosed the piece of land specifically for family members.

We believe these pillars constitute the governance framework for family waqf and family business waqf:

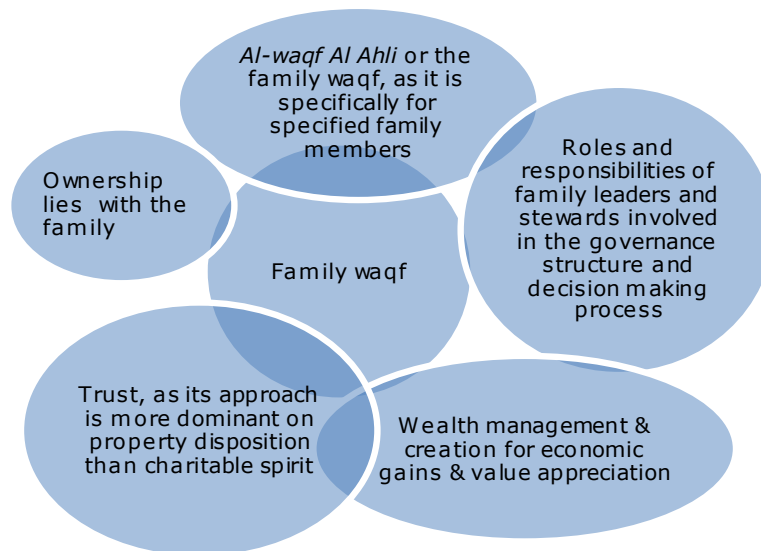

Figure 2: Governance Framework for Sustainable Family Waqf Management

Referring to the first author's case of family waqf, not-with-standing neither verbally declared nor written, the family waqf is validly created as the *waqif* (donor) – his great grandfather, then, was considered as indicating and disclosing (it). Abdul Jalil, Yahya & Pitchay (2019) in studying the role of information disclosure toward building a commitment to waqf, found future and trust information to be among the key antecedents.

The burial ground goes on benefitting the specified beneficiaries through-out generations which was a condition stipulated by the *waqif*. The burial ground had been specified, first for family members, and relatives, fulfilling the conditions stipulated by the *waqif*. Principally, the family waqf had been formed and practiced for generations as it was based on trust of the family members and relatives. In Islamic thought, a family waqf is charitable in nature (Malaysian Accounting Standards Board, 2018).

The *waqif* can be a natural person or legal person either rich or poor. But what Muslim families in business or families of wealth should consider when making decisions about family waqf? Family wealth constitutes not only financial capital but encompasses human capital, intellectual capital and social capital. Developing or setting family waqf in either of the four legal forms, incorporated company, registered society, registered trustee or an entity administered by a public entity, which should be perpetual in nature may be necessary as there are many Quranic injunctions on *faraidh* (law of inheritance) in which Allah (SWT) reminds the Muslim to be concerned about succession for their children (Mohamad, 2018).

Umar, Tasiu Tijani Kademi & Haron (2020) postulated that the essential features of waqf (irrevocability, inalienability and perpetuity) would not only prevent the family inheritable business from disposal or liquidation but also ensure that it remains a going concern to generate incomes for the welfare of the heirs, exempted heirs and other members of the Islamic society. Profit is expected to be shared among heirs based on the sharing ratio established by Islamic succession law. The exempted heirs and other members of Islamic society could benefit from the business profits continuously every year if the founder/owner of the business dedicates a certain share of its equity to them by way of a will.

But above all else, it may be required that not only the stewardship and involvement of family members who have the aptitude, sophistication, values and virtues demanded by this vehicle but also competent and qualified non-family trustees, advisors, consultants and managers. It requires long-term planning and management across multiple generations ensuring feasibility and sustainability. As in any waqf-based entrepreneurship, effective and efficient family waqf should result in economic gains from the administration, management and utilisation of the family business (Abdul Hamid & Mohammad Tahir Sabit, 2017).

Further, the *waqif* may not just be an individual but instead a family. It depends on who owns the family wealth at that decision-making point in time. Thus, if ownership rests with the family or a certain number of family members, then, the decision needs to be made collectively and by mutual consensus of the general assembly, but not according to the board of directors (AAOIFI, 2018).

The decision making or family governance process and structure at that time will influence the development and setting up of the family waqf. To create value alongside with proper governance for waqf reporting, Mansor, Jamil

& Bahari (2017) proposed an integrated system that aligns strategies with financial information and business prospects.

9.0 CONCLUSION

The case in point here is that for a family waqf and family business waqf, the concern and consideration should not just focus specifically on the family members and descendants as beneficiaries but also the roles and responsibilities of family leaders and stewards involved in the governance structure and decision-making process. Especially when the *waqif* is not the founder of the family business and the ownership of the wealth is no longer with the founder but with the family or family members.

It is also important that the family understands that the waqf cannot be sold, be made as a gift or inheritance. The waqf wealth or property should be managed separately from other family wealth and properties. To avoid mismanagement and conflict and without the needful mechanisms, governance and monitoring measures must be put in place, and it may be beneficial for the interest of the waqif and *mawqufalaih* for the waqf to be endowed or transferred to the SIRC.

REFERENCES

- Abdullah, M. (2018). Waqf and trust: The nature, structures and socio-impacts, *Journal of Islamic Accounting and Business Research*, 10(1), 512-527.
- Abdul Jalil, M.I., Yahya, S., & Pitchay, A.A. (2019). Building committed waqif: The role of information disclosure, *Journal of Islamic Accounting and Business Research*, 10(2), 185-215.
- Accounting and Auditing Organization for Islamic Financial Institutions Shari'ah Standards / Accounting and Auditing Organization for Islamic Financial Institutions (AAOIFI) (2018), pp. 1-1264.
- Casson, M. and Cox, H. (1997). An Economic Model of Inter-Firm Networks, in: Ebers, M. The formation of Inter-Organizational Networks, Oxford University Press, Oxford, pp. 174-196.
- Corbetta, G., & Salvato, C. A. (2004). The board of directors in family firms: One size fits all? *Family Business Review*, 17(2), 119-134.
- De Massis, A., & Kotlar, J. (2014). The case study method in family business research: Guidelines for qualitative scholarship, *Journal of Family Business Strategy*, 5(1), 15-29.
- Eisenhardt, K. M., & Graebner, M. E. (2007). Theory building from cases: Opportunities and challenges, *Academy of Management Journal*, 50(1), 25-32.
- Haji Mohiddin, H.M.N. (2015). Waqf development in Malaysia and Singapore, A comparative study, Durham theses, Durham University. Available at Durham E-Theses Online: <http://etheses.dur.ac.uk/11118/>
- Hoopes, J., Mohd. Nor, L., & Yusof, M. (2018). How to use virtue in business: Part A (Main Case), The Case Centre at Babson College and Harvard Business School Publishing.
- Lembaga Piawai Perakaunan Malaysia (Malaysian Accounting Standards Board) (2014). Research Paper Waqf Available at MASB Research Paper: http://www.masb.org.my/pdf.php?pdf=MASB%20Research%20Paper-Waqf.pdf&file_path=pdf
- Mohamad, N.A. (2018). A study on the socio-economic roles of *waqf ahli* (family waqf) in promoting family security and a sustainable family economy, *IJUM Law Journal*, 26(1), 142-160.
- Mansor, N., Jamil, A., & Bahari, A. (2017). Integrated waqf reporting system, *International Journal of Accounting, Finance and Business*, 2(6), 155-166.
- Abdul Hamid, M.I., & Mohammad Tahir Sabit, H.M. (2017). Waqf as a framework for entrepreneurship, *Humanomics: The International Journal of Systems and Ethics*, 33(4), 419-440.
- Mohd Nor, Leilanie (2014). An investigation into the decision making process in venture creation: A comparison between family business and non-family business, Dissertation for the Doctor of Philosophy, Universiti Tun Abdul Razak.
- Mohd Nor, L., Lechner, C., Yusof, M., Bardai, B., & Xavier, S.R. (2015). Family's Decision in Venture Creation for Next Generation Leaders: The Role of Trust Across Two Generations in the Case of Diversification, in Sharma, P., Auletta, N., DeWitt, R., Parada, M. & Yusof, M. (eds.). *Developing Next Generation Leaders for Transgenerational Entrepreneurial Family enterprises*. Edward Elgar Publishing Inc., Northampton, MA. (ISBN: 978-1-78471-786-5)
- Mohd Nor, L., & Yusof, M. (2014). Karangkraf: Growing while energizing Malaysian souls and minds, in Sharma, Pramodita; Yusof, Mohar; Parada, Maria Jose; DeWitt, Rocki-Lee; and Auletta, Nunzia (eds.), "Global STEP Booklet, Volume II; Sustaining Entrepreneurial Family Businesses: Developing the Core, Expanding the Boundaries". *STEP Summit Reports and Resources*. Paper 13. (ISBN: 978-0-9961664-0-9)
- Silivarajoo, P. (2018). Trustees incorporation of non-profit organization. Available at Legal Affairs Division (BHEUU), Prime Minister's Department: <http://www.bheuu.gov.my/pdf/ForumNPO2018/Dasar.pdf>
- Umar, U.H., Tasiu Tijjani Kademi, & Haron, M. H. (2020). Integrating waqf and business: Ensuring business sustainability for the welfare of heirs and non-heirs, *International Journal of Economics, Management and Accounting*, 28(1), 191-213.
- Yin, R.K. (1994). *Case study research. Design and methods* (2nd ed.), Thousand Oaks, CA: Sage Publications.
- Yusof, Mohar (2020). Six elements defining family business, *Business Today* magazine, February issue, 36-37.
- Yusof, M., Mohd Nor, L., & Hoopes, J. (2014). Virtuous CSR: An Islamic family business in Malaysia, *Journal of Family Business Management*, 4(2), 133-148.

PANDANGAN DAN PENDAPAT PENGGUNAAN APLIKASI GRABPAY OLEH PENGUSAHA-PENGUSAHA RESTORAN MAKANAN DI AEON TEBRAU DAN TOPPEN TEBRAU

Mohd Fazrin^a, Mohd Yusof^b, & Mohd Ghadafi^c

^{a,b,c} Politeknik METRO Johor Bahru, Malaysia

Abstrak

Saat ini, perkembangan Teknologi Kewangan (FinTech) menjadi penting dalam semua kegiatan ekonomi secara keseluruhan. Antara teknologi FinTech yang mudah dikenalpasti dan dilihat adalah e-dompet (e-wallet). Ada beberapa aplikasi di bawah e-dompet seperti Boost, Touch n Go wallet, Big Pay, PayPal, RazerPay, FavPay dan GrabPay. E-dompet banyak digunakan di pusat perbelanjaan, restoran, tol dan sebagainya. Namun sejauhmanakah pandangan dan pendapat restoran yang menggunakan e-dompet khususnya aplikasi GrabPay. Satu kajian telah dijalankan bagi melihat pandangan dan pendapat penggunaan aplikasi GrabPay oleh pengusaha-pengusaha restoran makanan di Aeon Tebrau dan Toppen Tebrau. Kajian dijalankan adalah menggunakan kaedah kualitatif iaitu melalui temubual. Enam responden iaitu pengurus restoran dipilih secara rawak dan ditemubual bagi mendapatkan pandangan dan pendapat penggunaan GrabPay. Kajian ini menyentuh tiga persoalan. Berapa orang yang menggunakan aplikasi GrabPay? Apa kelebihan yang dapat diperoleh pengguna dengan menggunakan aplikasi GrabPay? Apakah masalah yang dihadapi pengguna ketika menggunakan aplikasi GrabPay? Kajian ini mendapati bahawa semua responden bersetuju bahawa peratusan pelanggan yang menggunakan aplikasi GrabPay sangat rendah. Selanjutnya, banyak responden menyatakan bahawa penggunaan GrabPay adalah mudah dan senang digunakan. Di samping itu, terdapat kelebihan seperti mata ganjaran kepada pengguna. Untuk meningkatkan lagi penggunaan GrabPay, iklan harus dibuat di media sosial atau media massa. Namun, ada kekurangan dan kekhawatiran tentang penggunaan GrabPay yang perlu diperbaiki untuk melancarkan transaksi pembayaran. Terdapat beberapa cadangan pengkaji daripada kajian ini dimana, GrabPay harus memberikan tawaran menarik dengan harga yang berpatutan untuk menarik lebih banyak pelanggan menggunakan GrabPay ini. GrabPay mesti membuat kempen di pasar raya untuk mempromosikan atau memberitahu orang ramai bahawa aplikasi GrabPay ini akan memudahkan transaksi pembelian atau penjualan mereka. Akhirnya, GrabPay dapat memberikan kredit percuma kepada pengguna ketika mereka mula-mula menggunakan aplikasi tersebut. Oleh yang demikian, pengguna GrabPay akan lebih berminat untuk menggunakan aplikasi ini. Selain itu, diharap dengan kajian yang dijalankan dapat memberikan idea kepada pengkaji akan datang untuk membuat kajian berkaitan e-dompet. Secara keseluruhannya, kajian ini berjaya mencapai objektif kajian dalam melihat pandangan dan pendapat penggunaan aplikasi GrabPay oleh pengusaha-pengusaha restoran makanan di Aeon Tebrau dan Toppen Tebrau.

Kata Kunci: E-wallet, GrabPay, Pengusaha Restoran

1.0 PENDAHULUAN

Terdapat beberapa aplikasi di bawah e-dompet di Malaysia seperti Boost, Touch n Go wallet, Big Pay, PayPal, RazerPay, FavPay dan GrabPay. Jika dilihat di negara China, e-dompet hanya dikuasai oleh AliPay dan WeChat Pay. Di Malaysia, e-dompet yang paling popular adalah GrabPay. GrabPay telah diperkenalkan di Singapura adalah aplikasi yang mesra pengguna kerana mudah digunakan di mana sahaja dengan hanya mengimbas Quick Response Code (QR Code). Untuk menyiapkan akaun GrabPay, pengguna hanya perlu memasang perisian pada telefon pintar, dan memasukkan maklumat yang diperlukan. Setelah membeli-belah dalam talian, GrabPay secara automatik mengisi maklumat pengguna pada borang pembayaran. Untuk mengaktifkan GrabPay, pengguna perlu memasukkan kata laluan. Setelah pembayaran dalam talian dibuat, pengguna tidak perlu mengisi borang pesanan di laman web lain kerana maklumat tersebut disimpan di dalam pangkalan data dan dikemas kini secara automatik (Portal Rasmi Muamalat dan Kewangan Islam JAKIM). Dengan kemudahan transaksi pembayaran ini, GrabPay dapat membantu didalam merencanakan dan pemasaran perniagaan terutamanya pengusaha-pengusaha restoran makanan. Walaubagaimanapun, bagaimanakah pandangan dan pendapat pengguna aplikasi ini oleh kalangan pengusaha – pengusaha restoran makanan? Bagi menjawab persoalan yang bermain diminda pengkaji, pengkaji telah menetapkan satu objektif kajian iaitu melihat pandangan dan pendapat pengusaha-pengusaha restoran makanan mengenai penggunaan aplikasi GrabPay.

2.0 SOROTAN KAJIAN

Teknologi e-dompot merupakan satu keadaan ekonomi di mana urusan niaga kewangan tidak dijalankan dalam bentuk wang fizikal, melainkan melalui pemindahan maklumat digital antara pihak yang mengurus niaga (Azliah dan Syuhani 2019). Teknologi ini dilihat sebagai satu bentuk evolusi mata wang bagi proses pertukaran dan perniagaan (Atiqah dan Aisyah 2018). E-dompot merupakan bentuk pembayaran yang mudah dengan hanya memerlukan kod tersendiri dan pemindahan dengan menggunakan kod sahaja. Fenomena penggunaan e-dompot dilihat semakin meluas sejak bulan Mac yang lalu akibat penularan Pandemik Novel Corona Virus (Sinar Harian 5 Julai 2020). Sinar Harian 5 Julai 2020, menjelaskan bahawa penggunaan e-dompot di Malaysia adalah sebanyak 40 peratus diikuti Filipina (36 peratus), Thailand (27 peratus) dan Singapura (26 peratus). Selain itu, penggunaan tunai atau mata wang fizikal merosot kepada 64 peratus. E-dompot dilihat sebagai satu bentuk inovasi transaksi blockchain bagi mempercepatkan banyak transaksi dan mempermudah segala bentuk pembayaran (Portal Rasmi Muamalat dan Kewangan Islam JAKIM).

'Setiap perkara yang dianggap jual beli oleh manusia adalah dikira jual beli'

(Imam Malik
R.A)

Berdasarkan ungkapan daripada Imam Malik R.A menjelaskan bahawa di dalam Fiqh Muamalat, segala bentuk transaksi di dalam perniagaan adalah dibenarkan dan harus hukumnya selagi tidak mempunyai unsur-unsur yang dilarang dan diharamkan dalam Islam seperti riba, gharar, dan kezaliman (Portal Rasmi Muamalat dan Kewangan Islam JAKIM). Portal Rasmi Muamalat dan Kewangan Islam JAKIM telah menetapkan empat prinsip yang perlu diketahui sebelum membahaskan mengenai hukum hakam e-dompot. Empat prinsip tersebut adalah; Aplikasi dalam teknologi e-dompot adalah unik dan mempunyai ciri-ciri sekuriti, kaedah pemindahan, kaedah pengeluaran dan had e-wallet yang tersendiri. Penggunaan teknologi e-dompot telah diperluaskan kepada transaksi pertukaran jual beli. Teknologi e-dompot dilihat sebagai satu perkhidmatan pra bayar dimana nilainya khusus hanya tujuan pembayaran. Perlu difahami bahawa e-dompot hanya bertujuan pembayaran dan perekodan, bukan tujuan mendeposit atau pendeposit sejumlah wang.

Banyak persoalan mengenai hukum hakam e-dompot, namun perlulah diketahui bahawa teknologi transaksi e-dompot adalah harus selagi tidak mengandungi perkara yang dilarang dalam Islam. Syarikat penyediaan e-dompot hendaklah sentiasa peka terhadap isu halal haram dalam transaksi maupun promosi supaya e-dompot yang ditawarkan selari dengan hukum Islam (BH Online bertarikh 22 Julai 2019). Antara teknologi e-dompot yang terdapat di Malaysia adalah GrabPay. Satu kajian tinjauan telah dilakukan oleh iPrice Group dan App Annie bagi melihat lima e-dompot yang banyak digunakan di Malaysia bermula tahun 2017 hingga 2019. Hasil infografik mendapati GrabPay adalah tertinggi aplikasi e-dompot yang dimuat-turun dan digunakan, diikuti Touch 'N Go ditempat kedua, manakala Boost, Fave dan BigPay di tempat ketiga, keempat dan kelima (BH Online bertarikh 30 Oktober 2019). Kejayaan GrabPay dilihat daripada promosi yang berjaya, disamping telah bekerjasama dengan PayNet bagi menjadikan GrabPay sebagai e-dompot yang pertama di Malaysia yang menggunakan DuitNow QR dan Standard QR Nasional Malaysia (MyMetro bertarikh 15 Januari 2020).

3.0 METHODOLOGI KAJIAN

Kajian ini dilakukan dengan menggunakan kaedah temu-bual. Responden dipilih dan jumlah sampel responden adalah enam orang pengusaha restoran yang mempunyai urusan niaga menggunakan GrabPay di Aeon dan Toppen. Kod kategori dibuat untuk merahsiakan identiti responden. Kodnya adalah (R1, R2, R3, R4, R5, R6).

3.0 ANALISIS DAN KEPUTUSAN

Kesemua responden (R1, R2, R3, R4, R5, R6) menyatakan bahawa peratusan pelanggan yang menggunakan aplikasi GrabPay lebih rendah daripada penggunaan tunai. Namun R6 menjelaskan bahawa kurang pengetahuan mengenai penggunaan GrabPay. R6 menyatakan bahawa "mungkin di antara 10 peratus", R6 menjelaskan bahawa penggunaan GrabPay baru sahaja diperkenalkan dan tidak ramai yang mengetahuinya. Mengenai kelebihan-kelebihan yang ada dalam penggunaan GrabPay, responden R1 menyatakan bahawa penggunaan GrabPay adalah

senang dan mudah digunakan. Pernyataan R1 sama dengan R2, R4, dan R5. Ini kerana R1 menyatakan bahawa penggunaan GrabPay hanya perlu diimbangi menggunakan aplikasi QR code dan bahkan R3, R5, R6 mengatakan pelanggan tidak perlu "membawa wang tunai" untuk melakukan transaksi pembayaran. Selain itu, ketika melakukan transaksi pembayaran, nilai wang pengguna akan terus dikurangkan secara automatik semasa transaksi urusan niaga ke dalam akaun restoran. Pernyataan ini disokong oleh R1, R5 dan R6. mengatakan "wang akan dikreditkan di tempat".

Jadual 1: Pernyataan Responden Mengenai Kelebihan Menggunakan Aplikasi GrabPay

NO	PENYATAAN	RESPONDEN
1	Mudah untuk digunakan	R1, R2, R3, R4, R5
2	Imbas hanya pada aplikasi QR	R1, R2
3	Pelanggan mendapat wang tunai (<i>cash back</i>)	R2
4	Pelanggan mendapat mata ganjaran	R4
5	Transaksi nilai wang pelanggan automatik ditolak	R4
6	Wang akan dikreditkan terus ke akaun pengusaha restoran	R1, R5, R6
7	Tidak perlu membawa wang secara tunai	R3, R5, R6

Setiap kelebihan yang dinyatakan oleh setiap responden menggambarkan bahawa penggunaan GrabPay mempermudah urusan transaksi diantara pelanggan dengan pengusaha restoran, dimana hanya memerlukan imbasan QR tanpa memerlukan pelanggan membawa wang tunai secara fizikal. Disamping itu, pelanggan yang menggunakan GrabPay akan menikmati mata ganjaran daripada Syarikat Penyediaan GrabPay.

Jadual 2: Pernyataan Responden Mengenai Masalah GrabPay Yang Dihadapi Pengusaha

NO	PENYATAAN	RESPONDEN
1	Capaian aplikasi GrabPay yang lemah	R1, R6
2	Wang telah dikeluarkan dan tidak masuk ke dalam akaun peniaga	R2, R6
3	Masa untuk wang dikreditkan ke dalam akaun peniaga yang terlalu lama	R2
4	Sistem dan capaian talian internet yang rendah dan tidak memuaskan	R3, R6
5	Pelanggan hanya menggunakan GrabPay bagi mendapatkan mata ganjaran sahaja	R4

Jadual 2 menunjukkan pernyataan responden mengenai masalah GrabPay yang dihadapi oleh pengusaha restoran. Tiga masalah yang dinyatakan oleh dua responden adalah mengenai masalah capaian aplikasi, capaian internet yang lemah, dan wang telah dikeluarkan dari pembeli tetapi tidak masuk ke dalam akaun peniaga. Masalah ketiga-tiga ini dilihat merupakan faktor yang sering terjadi, terutamanya melibatkan masalah capaian internet. Mengenai masalah yang berkaitan dengan wang telah dikeluarkan dari pembeli tetapi tidak masuk ke dalam akaun peniaga, ini adalah perkara yang banyak dibimbangi oleh masyarakat. Berdasarkan MyMetro bertarikh 8 Julai 2019 menyatakan bahawa terdapat rakyat Malaysia yang bimbang mengenai kehilangan transaksi setelah menggunakan perkhidmatan e-dompot.

5.0 PERBINCANGAN DAN KESIMPULAN

Berdasarkan kepada maklumbalas daripada setiap responden, mereka sebulat suara mengatakan bahawa penggunaan GrabPay dapat memudahkan urusan mereka dan ianya adalah mudah untuk digunakan. Kemudahan ini banyak membantu merencanakan kaedah pembayaran di dalam perniagaan. Ini selari dengan kenyataan BH Online bertarikh 22 Julai 2019 yang menjelaskan bahawa teknologi ini mempercepatkan segala bentuk urusan yang berkaitan transaksi secara tradisional. Namun terdapat masalah yang perlu diambil perhatian oleh syarikat pengendali GrabPay, iaitu GrabPay hendaklah meningkatkan mutu perkhidmatan terutamanya didalam proses pemindahan transaksi agar masalah mengenai wang pelanggan tiada didalam akaun pihak pengusaha restoran dapat diatasi. Prakashbhai (2017) ada menyenaraikan beberapa masalah atau kelemahan didalam penggunaan e-dompot. Kelemahan yang dinyatakan oleh Prakashbhai (2017) adalah;

Tidak dapat digunakan secara meluas. Ini kerana tidak kesemua tempat ada menyediakan fasiliti-fasiliti yang menyokong kepada teknologi e-dompot.

Lagi banyak syarikat penyediaan e-dompot menawarkan teknologi e-dompot, makin banyak pengguna terperangkap untuk banyak berbelanja. Ini akan menyebabkan kurang kesedaran didalam berbelanja berhemah.

Risiko kepada pendedahan maklumat peribadi. Isu ini banyak menjadi kerisauan kepada masyarakat. Syarikat penyediaan e-dompot dan kerajaan perlu mengambil perhatian dan menyediakan langkah-langkah bagi mengekang masalah risiko kes penipuan dalam talian dan penggodaman maklumat.

Terdedah kepada risiko kegagalan e-dompot. E-dompot bergantung kepada aplikasi dan telefon pintar. Ini mendedahkan pengguna e-dompot kepada kegagalan fungsi disebabkan pelbagai faktor seperti gangguan internet atau kerosakan pada telefon pintar.

Daripada kenyataan yang diberikan oleh Prakashbhai (2017) ini menjelaskan bahawa perlu bagi pihak-pihak yang berkepentingan dan pihak yang berwajib untuk memastikan masalah-masalah kelemahan tersebut dapat diperbaiki agar teknologi e-dompot di Malaysia dapat berkembang dan diperluaskan. Berdasarkan dapatan yang diperolehi, pengkaji mencadangkan agar kajian akan datang mengkaji berkenaan kebaikan dan kelemahan secara lebih berfokus kepada faktor-faktor yang berkait rapat dengan e-dompot. Cadangan kaedah lebih tertumpu kepada kajian kuantitatif. Selain itu, jumlah responden perlulah merangkumi pengguna dan pengusaha restoran mencakupi keseluruhan populasi. Pemilihan ini membolehkan persepsi yang diperolehi bertepatan dengan permasalahan sebenar e-dompot. Secara keseluruhannya, objektif kajian telah dicapai bagi melihat pandangan dan pendapat penggunaan aplikasi GrabPay oleh pengusaha-pengusaha restoran makanan di Aeon Tebrau dan Toppen Tebrau. Diharap dengan kajian ini dapat membantu pihak yang berkaitan isu-isu berkaitan dengan teknologi aplikasi e-dompot.

REFERENCES

- BERNAMA (30 Oktober 2019). e-dompot aplikasi paling aktif diguna di Malaysia. BH Online. Artikel Penuh : <https://www.bharian.com.my/bisnes/teknologi/2019/10/623187/e-dompot-aplikasi-paling-aktif-diguna-di-malaysia>
- Dr Azrul Azlan Iskandar Mirza (22 Julai 2019). e-Wallet patuh syariah?. BH Online. Artikel Penuh : <https://www.bharian.com.my/rencana/agama/2019/07/587707/e-wallet-patuh-syariah>
- Jabatan Kemajuan Islam Malaysia JAKIM. Aplikasi e-Wallet: Adakah Ia Mematuhi Syariah?. Portal Rasmi Muamalat dan Kewangan Islam. <http://e-muamalat.islam.gov.my/ms/bahan-ilmiah/artikel/453-aplikasi-e-wallet-adakah-ia-mematuhi-syariah>
- Mansi Prakashbhai Bosamia (2017). Mobile Wallet Payments Recent Potential Threats and Vulnerabilities with its possible security Measures. Conference: 2017 International Conference on Soft Computing and its Engineering Applications (icSoftComp-2017)
- MyMetro (15 Januari 2020). GrabPay, e-dompot rakyat percepatkan ekonomi digital Malaysia. Artikel Penuh : <https://www.hmetro.com.my/mutakhir/2020/01/535366/grabpay-e-dompot-rakyat-percepatkan-ekonomi-digital-malaysia>
- Nor Azliza bt Saad dan Nor Syuhani bt Shaari (2019). Persepsi Pelajar Terhadap Pelaksanaan Konsep Urusniaga Tanpa Tunai Di Politeknik Sultan Abdul Halim Mu'adzam Shah (POLIMAS). Journal on Technical and Vocational Education (JTVE), Vol 4 No 2, pp. 36 – 46.
- Nurulain Atiqah Zain Azmi dan Aisyah Abdul-Rahman (2018). Kesedaran Pelajar Terhadap Risiko Bitcoin. Jurnal Personalia Pelajar, pp .67-77
- Ong Boon Teck (5 Julai 2020). Covid-19 ubahn rakyat guna e-wallet. Sinar Harian. Artikel Penuh: <https://www.sinarharian.com.my/article/90777/BERITA/Dari-Media-Cina/Covid-19-ubah-rakyat-guna-e-wallet>

FROM THE LENS OF MAQASID AL-SHARIAH: ATTAINING QUALITY OF LIFE THROUGH FLEXIBLE WORK

Sharifah Rahama Amirul^a and Sharifa Che Shaari^b

^a Lecturer, Faculty of Business, Economics and Accountancy, Universiti Malaysia Sabah, Kota Kinabalu, Sabah, Malaysia

Abstract

The past decades have seen an increasing interest in studying flexible working arrangements (FWAs) because of the dramatic transformation in technologies, business operations that work across globalisation and the changes of socio-economic profiles around the world. There seems to be a growing literature discussing Maqasid Al-Shariah. Nevertheless, the existing literature seems to have not delved far into analysing the FWAs studies from the lens of Maqasid Al-Shariah. Therefore, this paper intends to pioneer the exploration of flexible work in attaining the quality of life from the context of Maqasid Al-Shariah. This paper will briefly explain the five principles of Maqasid Al-Shariah, namely, *Hifz Ad-diin* (religion); *Hifz An-Nafs* (life); *Hifz Al-Aql* (intellect), *Hifz Al-Mal* (wealth); *Hifz An-Nas* (posterity). The discussion will later focus on the principles associated with attaining the quality of life through flexible work. This is a relatively new study in FWAs research field and expected to contribute new facet in FWAs study, and that will extend the existing literature in FWAs and works as a foundation for further investigation of FWAs studies from the perspective of Maqasid Al-Shariah.

Keywords: Maqasid Al-Shariah, Flexible Work, Quality of Life

INTRODUCTION

Flexible work is not a new practice in the fast and emerging economic world as it promises various benefits coveted by people in this 21st century. For instance, flexible working arrangements (FWAs) have been used as a tool to harmonise between work-life balance (e.g. Downes & Koekemoer, 2011; Havman, 2009; Richardson & Mckenna, 2014), which are important to maintaining both mental and physical health (Currie, 2001). Workers with harmonised work-life balance are not merely important for employee's well-being but also critical to enhance performance in an organisation (Richardson & Mckenna, 2014). On the other hand, FWAs have been recognised as a mechanism for improving employee's productivity (Golden, 2011; Kauffeld, Nakamura, Kaihatsu, & Yagi, 2018; Pedersen et al. 2009; Regus, 2012; Ringdal, 2009; Voordt, 2004) and broadly improved national economic growth (International Labour Office, 2015; Nakamura et al., 2018; Regus, 2012). Plenty of FWAs studies have revolved around the above context which emphasises on the importance of FWAs and its benefits to individuals as well as to society. However, as far as the study is concerned, to associate FWAs studies within the context of Maqasid Al-Shariah is unexplored in the existing literature. Thus, this paper intends to understand and investigate the links between FWAs and the field of Maqasid Al-Shariah. By exploring this intriguing research area, this paper seeks to reflect the FWAs in the light of Maqasid Al-Shariah.

1.0 ISLAMIC VIEW ON WORK

Islam is not a mere religion; it is a way of life. The word "Islam" originated from the Arabic root word which means for "total surrender", "submission", "obedience", "purity of heart" and "peace". Thus, the meaning of Islam itself means complete submission to the will of Allah (SWT) in all aspects of life. Islam teaches that people can only find peace in one's life by submitting to Allah (SWT) in heart, soul and deed.

It is the primary aim in life that a Muslim to worship Allah, the Creator of the Universe, to succeed both in this life and in the life hereafter. Almighty Allah (SWT) creates mankind to be His Caliph (*Khalifah*). In English, the Arabic word 'Khalifah' is often translated as 'vicegerent'. Vicegerent means one who acts in the place of the leader or king. Included in the meaning of vicegerent is the assumption that the person in that role will act in every instance as the leader or king would want them to act (Mustaffa Mohamed Zain et al: 2014). Thus, Allah (SWT) created mankind to be His representative on earth. Hence it is expected that mankind shall act in all circumstances as prescribed by Allah (SWT).

To a Muslim, the whole purpose of life is "ibadah" which means worshipping the Almighty Allah (SWT) that includes all acts of obedience to Almighty Allah (SWT). Islam not only reflects the relations between the Creator

and human being, but the deliberation encompasses the relation between man and man; and man and the entire universe. Thus, Islam provides general principles and general guidelines that cover all aspect of life.

The Islamic teachings are primarily instituted in the two main sources of its teachings, the Qur'an (the words of Almighty Allah) and the Sunnah (a collection of sayings of the prophet Muhammad (PBUH) and accounts of prophet Muhammad's daily practice). There are secondary sources, namely the Ijma' (consensus) and Qiyas (analogy). Fiqh maxims also form as guidance in determining a solution to a particular issue as long as they do not contradict with the Quran and Sunnah.

2.0 MAQASID AL-SHARIAH

The term *Maqasid* is a plural word from *maqsid*, which refers to a purpose, objective, principle, intent, goal (Abiodun & Ab Rahman, 2016, Auda, 2016). Shariah implies divine Islamic law that governs the behaviour of a Muslim individual towards his or herself, family, neighbours, community, city, nation, and the Muslim polity as a whole, the Ummah (global Muslim community), and everyone under Islam's jurisdiction. Similarly, Shariah governs the interactions between communities, groups, and social and economic organizations (Alashari, 2019). Thus, the combination of the two words theoretically implies the theory on the objectives of Islamic law, which cover every aspect of human existence, human development, and individual general well-being (Abiodun & Ab Rahman, 2016). The most prominent Shariah scholars, Abu Hamid Al-Ghazālī (1111 CE) and Abd al-Malik al-Juwayni (1185 CE) emphasised that the main goal of shariah is securing the interests of all human beings (*al-masālih*) and protecting them from harm (*al-mafāsīd*). AlOarafi (1868 CE) fundamentally linked between *maslahah* and *maqasid* by which, a purpose or *maqasid* is not valid unless it leads to the fulfilment of some good (*maslahah*) or the avoidance of some mischief (*mafsadah*).

2.1 Classification of Maqasid Al-Shariah

Islam is not a mere religion; it is a way of life. The word "Islam" originated from the Arabic root word which means for "total surrender", "submission", "obedience", "purity of heart" and "peace". Thus, the meaning of Islam itself means complete

The classifications of *maqasid* are divided into three 'levels of necessity,' which are necessities (*daruriyyah*), needs (*hajjiyyah*), and luxuries (*tahsiniyyah*). Necessities (*daruriyyah*) are further classified into what preserves one's faith, soul, wealth, mind, and offspring (Auda, 2016). Imam As-Shatibi said (see al-Muwafaqat, 2/17)

Meaning: *Daruriyyah* is something that must exist to create *maslahah* (benefits) of religion and the world. Without the existence of these basic interests (needs for life), the affairs of worldly life will be disrupted (not in the right paths). The world life will be damaged, chaotic and life will be destroyed. While the prosperity and enjoyment at *akhirah* (hereafter) will be lost, and return with a real loss.

Needs are complementary elements that relieve people's life as it removes difficulties (Abiodun & Ab Rahman, 2016). Luxuries defined by Auda (2016) as beautifying purposes and adding elegance into life. Abiodun and Ab Rahman (2016) added that this level is an embellishment which is related to moral and ethical conducts in a system. For this paper, the classification of Maqasid Al-Shariah will be based on the definition given by Al-Ghazālī (1111 CE), who asserted that *maqasid* emphasises the Shariah concern for safeguarding the five objectives in *daruriyyah* level: safeguarding *hifz ad-diin* (religion), *hifz an-nafs* (life), *hifz al-aql* (intellect), *hifz al-mal* (wealth) and *hifz an-nas* (posterity).

2.2 Comparison between Maqasid Al-Shariah and Maslow's hierarchy of Needs Theory

In the seminal works of Auda (2008), he compared the theory of Hierarchy of Needs propounded by Abraham Maslow, with Maqasid Al-Shariah. Auda (2008) asserted that Abraham Maslow's theory is a motivational theory focused on the hierarchy of human objectives or basic goals, rather than 'divine'. Maslow's theory was first coined in 1943, which ranges from the basic needs of physiological requirements and safety to love and esteem, and to 'self-actualization. As illustrated by Figure 1, it can be seen that both Maqasid Shariah and Maslow theory is to fulfil human needs and wants. Nevertheless, the big difference between the two is that Maqasid Shariah is not limited in fulfilling the human needs and wants per se, but the purposes also specifically seek divine goals. For example, the fundamental of Maqasid Shariah is *Maslahah* by giving benefits and avoiding badness for humanity, and *Al-Falah*, where the ultimate goal is not merely for *ad-diniyyah* (world) but also for *akhirah* (hereafter). Hence, Maqasid Al-Shariah can be used as a means of social control over the changes that are taking place in human life (Bahruddin, 2017).

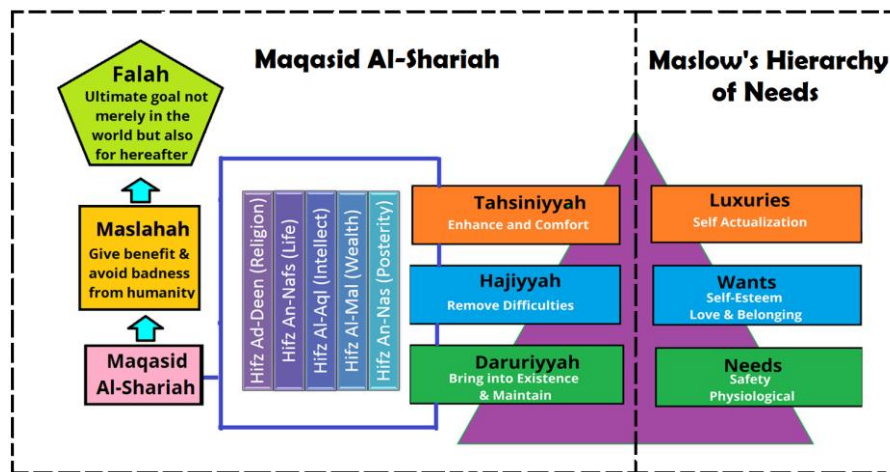

Figure 1: Human Needs from the lens of Maqasid Al-Shariah and Maslow's Hierarchy of Needs

2.3. Bridging Maqasid Al-Shariah and Flexible Work in Attaining a Quality of Life

As discussed earlier, the fundamental element of Maqasid Shariah is Maslahah (giving benefits and avoiding badness for humanity) and that will be fulfilling the purposes of Al-Falah (for the world and hereafter). Many angles that can be associated between Maqasid Al-Shariah and flexible work. These angles will be briefly explained accordingly to each of five Maqasid Al-Shariah classification as explained by Imam Al-Ghazali (1111 CE).

2.4 Hifz Ad-Deen (Religion)

Imam Abu Hayyan explained that the word *Ad-deen* means religion and shariah (see Tafsir Al-Bahr Al-Muhit, 3/171). In the life of a Muslim, it cannot be separated from *ad-deen* (religion), because Islam encompasses all aspect of human life. Rashid and Mamat (2013) highlighted that Islam is a religion that emphasises the overall human life. It covers all aspects of the physical body, the soul or the spirit, the emotion and the intellect with the sole purpose of producing individuals who are able wholeheartedly to enslave themselves to the Allah almighty in all sectors of their lives. In the existing literature, plenty of studies have significantly proved that flexible work is a remedy or solution to work-life balance (e.g. Downes & Koekemoer, 2011; Hayman, 2009; Galea, Houkes & De Rijk, 2014; Richardson & Mckenna, 2014). However, the current literature seems to have not delved far into analysing the need for work-life balance from the *ad-deen* aspect. Under Title VII of the Civil Rights Act of 1964 of United States, employers must reasonably accommodate employees sincerely held religious, ethical and moral beliefs or practices unless doing so would impose an undue hardship on the employer. To date, there is no regulation in Malaysia to protect individuals' legal right to request for flexible working as in other countries like Australia and the United Kingdom, which is known as statutory application. The needs of flexible working are seen to be important for a busy work schedule to enable Muslim to perform obligatory prayer (5 times a day) as well as allowing Muslim to have space of time for studying or educating religion.

2.5 Hifz An-Nafs (Life)

Ibn Manzur (2012) justified *An-nafs* as human spirit and body. Mohamad et al. (2017) asserted *An-nafs* is not solely about taking care of life. The use of word *An-nafs* refers to some important qualities in human beings namely emotion (*wijdan*), feeling (*shu'ur*), sensation (*ihsas*) whether translated to behaviour or not. *An-nafs* also means a human substance or essence, that is the main element of doing something for himself. It encourages people to strive to achieve the desire within him. It encourages the human spirit, which is an essential element of a human being to live. In the modern world where there are rising dependencies on global market forces place an ever-greater burden on those of working age in the delivery of products and services. This, in turn, has had a negative effect on the health and wellbeing of workers (Babstiste, 2008). Flexible work arrangements (FWAs) have been used as a method to decrease job stress as a result of achieving work-life balance, and health and safety at work (Ayman, Ashoush, ELayed & Younis, 2015). The benefits offered by the flexible working arrangements are in line with the element of Maqasid Al-Shariah which emphasises the importance of human life must be taken care of either emotionally, spiritually or physically. New research suggests linkages between support for flexible work schedules and health including heart rates, blood pressure, sleep quality, depressive symptoms, and physical pain (Kossek & Hammer, 2008). Therefore, it has been significantly proved that flexible work can be a remedy to both physical and emotional well-being of employees.

2.6 Hifz Al-Aql (Intellect)

Intellect is a blessing from Allah SWT that is very valuable to human beings, and the burden of responsibility is given to humans because of their intellect. Therefore, the maintenance of mind is very important to ensure its insanity, healthy and perfect function. In this regards, Islam forbids its followers to take anything that could bring damage to their mind (Wahab, AB Hamid, Che Man & Hashim, 2019). Work and mental illness are intertwined. A recent study conducted by Mental Health America (MHA) (2019) indicates that employees experiencing problems with work might exacerbate mental health concerns. MHA's survey with more than 9000 respondents represent individuals who are most at risk of burnout, low employee engagement, and poor employee wellbeing. In addition to that, De Ceira (2011) also asserted that serious health conditions such as mental illness can be derived from long working hours (De Ceira, 2011). Flexible working arrangements (FWAs) have been proven to support mental health at work and life. A piece of recent information shared by the World Health Organisation (WHO) (2019) confirmed that inflexible working hours has become one of the risks to mental health. WHO (2019) asserted that organisations have a responsibility to support individuals with mental disorders by implementing flexible hours, job-redesign, addressing negative workplace dynamics, and supportive and confidential communication with management can help people with mental disorders continue to or return to work.

2.7 Hifz Al-Mal (Wealth)

Hifz al-mal (preservation of wealth) is one of the most important objectives of the Shariah. The Muslim jurists assert that the concept of *Hifz al-mal* goes beyond its literal meaning (Auda, 2016). It does not mean to preserve the wealth per se, but the concept also covers the encouragement to generate, accumulate, preserve as well as distribute the wealth in a just and fair manner. Working hard for the material well-being of one's own self, family and society is as spiritually as the offering of prayers provided that the material effort is guided by spiritual values (Khurshid, 1980).

Zakaria and Abdul Malek (2014) explained that the needs for wealth are combined with the physiology needs of Maslow's hierarchy of needs of human. In human life, the very basic needs include food, water, shelter, cloth, and sex. In today's modern life, basic needs also include sanitation, healthcare and education. To fulfil these needs, humans should possess wealth (Zakaria & Abdul Malek, 2014). Wealth is very essential to safeguard the basic physical and material well-being of individuals. *Hifz Al Mal* or wealth can be closely related to FWAs, as it works as a tool for an individual to gain wealth to acquire the basic need for life. For example, an individual with childcare responsibility or need to look after the elderly or sick family member may be struggling to fulfil work commitment with a rigid working hour. Most likely they will be losing a job or perceived as an underperforming worker, which may disrupt their income. Besides, rigid working hours have made it difficult to Islamic preachers, whether the preachers had to quit from his job and focus on his da'wah (preaching) work or had to stop/reduce the da'wah work because they need to work for family survival. Through flexible work, it would assist Islamic preacher to have enough financial for their family survival and at the same time, they could continue their preach (da'wah) and inviting/giving *maslahah* (benefits) to society and reminding to avoid badness, where the ultimate goal is not merely for *ad-diniyyah* (world) but also for *akhirah* (hereafter).

2.8 Hifz An-Nas (Posterity/lineage)

The fifth classification is *Hif An-Nas* which refers to the right to posterity, i.e. the future generations of a family (Auda, 2008). Family lineage has become one of *daruriyyah* in Maqasid Syariah, which attained through encouraging marriage as well as respecting and acknowledging family lineage. Prophet Muhammad SAW said in authentic hadith by Muslim "Nikah (marriage) is my sunnah (way of life)." Therefore, it is strongly recommended by Islamic faith since it protects and maintains human lineage (*Hifz An-Nas*) which is important as protecting human life (*Hifz An-Nafs*). The connection of FWAs and *Hifz An-Nas* can be seen through the term of marriage. Klinenberg and Ansari (2015) asserted that marriage rates will decline during the economic hard times. The importance of FWAs implementation to maintain work-life balance have been proven to benefit the organisations and the economy of the nation. Several scholars (Golden, 2011; Kauffeld, Jonas, & Frey, 2004; Nakamura, Kaihatsu, & Yagi, 2018; Pedersen et.al, 2009) significantly found that FWAs increase employee productivity which is necessary to sustain a profitable business and investment, and these FWAs more broadly improved national economic growth (Biesebroeck, 2015; Nakamura et al., 2018). In addition to that, people are putting off marriage because of a busy work schedule. FWA is deemed to be a great solution to the above issues. FWAs can be one of remedy to busy work schedule because the most common benefit of FWAs to an employee is work-life balance (Casper & Harris, 2008; Grover & Crooker, 1995; Hayman, 2009; Lewis & Roper, 2008; William et.al., 2018). Through FWAs employees can put their focus on both work and personal life such as marriage. Islam has emphasised on posterity as it ensures maintenance of physical and mental well-being. It starts with being a good person because it is pertinent to society to have human affection and a sense of responsibility those in need. Islam

prohibits intolerant behaviour toward others.

صُرِّبَتْ عَلَيْهِمُ الدَّلِيلَةُ أَنَّهُمْ مَا تُقْفُوا إِلَّا بِحَبْلِ مِّنَ اللَّهِ وَحَبْلِ مِّنَ النَّاسِ
وَبَاءُ وَبِعَضِّ مِّنَ اللَّهِ وَصُرِّبَتْ عَلَيْهِمُ الْمَسْكَنَةُ ذَلِكَ بِأَنَّهُمْ
كَانُوا يَكْفُرُونَ بِآيَاتِ اللَّهِ وَيَقْتُلُونَ الْأَنْبِيَاءَ بِغَيْرِ حَقِّ ذَلِكَ بِمَا
عَصَوْا وَكَانُوا يَعْتَدُونَ ﴿١١٢﴾

They have been put under humiliation [by Allah] wherever they are overtaken, except for a covenant from Allah and a rope from the Muslims. And they have drawn upon themselves anger from Allah and have been put under destitution. That is because they disbelieved in the verses of Allah and killed without right. That is because they disobeyed and [habitually] transgressed. (Ali-Imran: 112)

3.0 CONCLUSION

Work is regarded as *ibadah* and the ultimate goal for the Muslims is to seek the Creator's blessings so that we are duly rewarded both in this present world and hereafter. Islam promotes a balanced life. Therefore, employers and employees must know the duties imposed upon them. They must display their best effort to fulfil their duties so as not cause injustice to the other. The objective of flexible work is to attain the quality of life. In Islam, work is regarded as an *ibadah* for the ultimate *falah*. An employee must fulfil his obligations as the vicegerent, not only for his self-interest of an individual but also to his *ummah* and mankind.

The classifications of Maqasid Al-Shariah relating to *Hifz Ad-Deen* (Religion), *Hifz An-Nafs* (Life) and *Hifz Al-Aql* (Intellect) are closely related to the area concerning flexible work. The essence of *maslahah* embodied in the principles of Maqasid Al-Shariah binds both employers and employees to ensure that neither parties are discriminated and/or caused any injustice. In conclusion, flexible work from the lens of Maqasid Al-Shariah is not merely concerned with the attainment of the quality of life per se. The Maqasid Al-Shariah goes beyond the quality of life. The principles of Maqasid Al-Shariah delve further in placing work for the Muslims to attain blessings from the Creator, Allah SWT to succeed both in this life and in the life hereafter.

ACKNOWLEDGEMENTS

This article is derived from our research entitled "Embracing the Flexible Working Arrangements (FWAs) Post Covid-19: A Socio-Legal Study" (SDK0177-2020). The authors would like to extend their gratitude to the Universiti Malaysia Sabah (UMS) for funding the research.

REFERENCES

- Al-Juwaini, Abdul-Malik (1400 AH). *Al-Burhan Fi Usul Al-Fiqh*
- Al-Ghazaly, Abu Hamid (1413 AH). *Al-Mustasfa Fi Ilm Al-Usul*
- Al-Syatibi, I. M. (2010). *Al-Muwafaqat*. Beirut: Dar al-Ma'rifah
- Abdul Rahman I. Doi (1984) *Shariah: the Islamic Law*. Kuala Lumpur: A.S. Nordeen Publishers
- Ahmad, K.(ed) (1980) *Studies in Islamic Economics*. Leicester: The Islamic Foundation (United Kingdom)
- Alashari, Muhammad (2019). Everything you need to know about Sharia/Islamic law. https://www.researchgate.net/publication/335320513_Everything_You_Need_to_Know_About_ShariaIslamic_Law
- Al-Qarafi, Shihabuddin (1994). *Al-Dhakheerah*. Beirut: Dar al-Arab.
- Auda, J. (2008) *Maqasid Al-Shariah as Philosophy of Islamic Law: A System Approach*. Washington: The International Institute of Islamic Thought
- Auda, J. (2016) How do We Realise Maqasid Al-Shariah in the Shariah? Accessible at <https://www.jasserauda.net/portal/wp-content/uploads/2016/12/4.pdf> Retrieved on 30 Aug 2020
- Ayman, M., Ashoush, A.-L., Elsayed, A. A., & Younis, R. A. (2015). Flexible work arrangements: Related topics and directions. *Journal of Business Studies Quarterly*, 7 (1),
- Baptiste, N. R. (2008). Tightening the link between employee wellbeing at work and performance: A new dimension for HRM. *Management Decision*, 46(2), 284–309. <http://doi.org/10.1108/00251740810854168>
- Biesebroek, J. Van. (2015). How tight is the link between wages and productivity? A survey of the literature. (54).
- Casper, W. J., & Harris, C. M. (2008). Work-life benefits and organizational attachment: Self-interest utility and signaling theory models. *Journal of Vocational Behavior*, 72(1), 95–109.
- Currie, D., (2001), *Managing Employee Well-Being*, Chandos Publishing Oxford Limited, Oxford
- De Ceira, H. (2011). Work Life Balance Policy, (February), 4–21.
- Downes, C., & Koekemoer, E. (2011). Work–life balance policies: Challenges and benefits associated with implementing flexitime. *SA Journal of Human Resource Management*, 9, 1–13. <http://doi.org/10.4102/sajhrm.v9i1.382>
- Galea, C., Houkes, I., & De Rijk, A. (2014). An insider's point of view: How a system of flexible working hours helps employees to strike a proper balance between work and personal life. *International Journal of Human Resource Management*. Taylor & Francis. <http://doi.org/10.1080/09585192.2013.816862>
- Golden, L. (2011). The effects of working time on productivity and firm performance: a research synthesis paper. *Conditions of Work and Employment Series*, (33), 1–34.
- Grover, S.L., and Crooker, K.J. (1995), 'Who Appreciates Family-Responsive Human Resource Policy,' *Personnel Psychology*, 48, 2, 271–288.
- Hayman, J. R. (2009). Flexible work arrangements: exploring the linkages between perceived usability of flexible work schedules and work/life balance. *Community, Work & Family*, 12(March 2013), 327–338. <http://doi.org/10.1080/13668800902966331>
- Ibn Manzur (2012). *Lisan Al-'Arab*, Translation of Al-Qamus, 1:1232.
- Abiodun Oladapo, Ibrahim; Ab Rahman, Asmak. Maqasid Sharī'ah: The Drive For An Inclusive Human Development Policy. *Jurnal Syariah*, [S.l.], v. 24, n. 2, July 2017. ISSN 0127-1237
- Kauffman, S., Jonas, E., & Frey, D. (2004). Effects of a flexible work-time design on employee-and company-related aims. *European Journal of Work and Organizational Psychology*. 13(1), p. 79-100.
- Khurshid (1980). *Studies in Islamic Economics*. Jiddah: ICRIE.
- Klinenberg, Eric and Ansari, Aziz (2015). *Modern romance*. 1st Ed. Penguin Books Publisher.
- Kossek, E.E. and Hammer, L.B. (2008). Supervisor Work/Life Training gets results. *Harvard Business Review*
- Lewis, Suzan and Roper, Ian (2008) Flexibility and work-life balance. In: *Human resource management: a case study approach*. Muller-Camen, Michael and Croucher, Richard and Leigh, Susan, eds. Chartered Institute of Personnel and Development, London, pp. 181-199.
- Mental Health America (MHA) (2019). *Mind the workplace*. Accessed from <https://mhanational.org/sites/default/files/Work%20Health%20Survey%202019.pdf>
- Nakamura, K., Kaihatsu, S., & Yagi, T. (2018). Productivity Improvement and Economic Growth. *IDEAS Working Paper Series from RePEc*,
- Pedersen, D. E., Minnote, K. L., Kiger, G., & Mannon, S. E. (2009). Workplace policy and environment, family role quality, and positive family-to-work spillover. *Journal of Family and Economic Issues*, 30, 80-89.
- Rashid, A.A and Mamat, A. (2013). Educational view of the Islamic leadership: are the Islamic leaders performing their responsibilities? *International Journal of Humanities and Social Science* 3(3): 178-179.
- Regus. (2012). Flexibility Drives Productivity, (February). Retrieved from http://www.regus.com/images/Flexibility_Drives_Productivity_tcm8-49367.pdf
- Richardson, J., and McKenna, S. (2014). Reordering spatial and social relations: a case study of professional and managerial flexworkers. *Br. J. Manage.* 25, 724–736. doi: 10.1111/1467-8551.12017
- Van der Meer, P. H., & Ringdal, K. (2009). Flexibility practices, wages and productivity: evidence from Norway. *Personnel Review*, 38(5), 526–543. <http://doi.org/10.1108/00483480910978036>
- Voordt, T. J. M. Van Der. (2004). Productivity and employee satisfaction in flexible workplaces. *Journal of Corporate Real Estate*, 6(2), 133–148. <http://doi.org/10.1108/14630010410812306>
- Williams, P., Cathcart, A., & McDonald, P. (2018). Signals of support: flexible work for mutual gain. *International Journal of Human Resource Management*, 0(0), 1–25. <http://doi.org/10.1080/09585192.2018.1499669>
- World Health Organisation (WHO) (2019). *Mental health in the workplace*. Accessed from who.int/mental_health/in_the_workplace/en/
- Zakaria, Maheran and Abdul Malek, Nur Ain (2014). Effects of Human Needs Based on the Integration of Needs as Stipulated in Maqasid Syariah and Maslow's Hierarchy of Needs on Zakah Distribution Efficiency of Asnaf Assistance Business Program. *Jurnal Pengurusan* 40(2014) 41 - 52

NIAT DARIPADA PERSPEKTIF ISLAM DALAM AKTIVITI KEPENGGUNAAN

Azmawida Abdullah^{*a}, Mohd Murshidi Mohd Noor^b & Syarifah Md Yusof^a

Abstrak

Niat adalah suatu yang amat penting dalam ajaran Islam. Niat mampu menentukan sesuatu tindakan seseorang Muslim berpahala atau tidak. Ruang lingkup niat dalam ajaran Islam tidak terhad hanya dalam ibadah khusus, bahkan niat turut meliputi perkara mubah seperti aktiviti kepenggunaan. Terdapat perbincangan yang meluas berkaitan niat dalam aktiviti kepenggunaan menurut persektif Barat. Namun, niat menurut pandangan Islam dalam aktiviti kepenggunaan agak kurang diberi perhatian oleh sarjana dan pengkaji, sedangkan topik ini amat penting. Hal demikian kerana niat akan mempengaruhi tindakan dan gelagat pengguna. Kertas kerja ini akan membincangkan niat dalam konteks kepenggunaan Islam. Ia akan memberi implikasi kepada gelagat pengguna Muslim dan seterusnya boleh memberi kesan kepada ekonomi umat Islam pada masa hadapan.

Katakunci: Niat, Ikhlas, Pendorong, Pengguna Muslim, Islam, Kepenggunaan

1.0 PENGENALAN

Niat merupakan satu perkara yang sangat penting di dalam Islam bagi menentukan keabsahan sesuatu ibadah atau pendorong kepada perlakuan baik. Sepatutnya bagi pengkaji Muslim yang ingin mengkaji mengenai niat, perlulah merujuk kepada karya-karya yang dihasilkan oleh para ilmuwan Islam. Namun, kebanyakan kajian berkaitan niat pada masa kini dirujuk kepada teori yang diperkenalkan oleh sarjana Barat, walaupun kajian dilakukan terhadap pengguna Muslim. Justeru, kertas kerja ini bertujuan membincangkan niat di dalam Islam dan keterkaitannya dengan aktiviti kepenggunaan. Penulis merujuk kepada buku-buku karya ulama silam dan kontemporari yang membincangkan niat dalam Islam. Artikel-artikel terbitan semasa oleh pengkaji masa kini berkaitan niat dan kepenggunaan turut dirujuk bagi mendapatkan kesimpulan berkaitan niat dalam kepenggunaan. Perbincangan dalam kertas kerja ini dimulakan dengan niat daripada perspektif Islam. Seterusnya perbincangan ini diteruskan dengan definisi niat, sumber perbincangan niat, kepentingan serta fungsi niat, perbincangan niat dalam ibadat khusus dan umum serta perkaitan niat dan kepenggunaan. Kertas kerja ini diakhiri dengan kesimpulan dan implikasi.

2.0 NIAT DARIPADA PERSPEKTIF ISLAM

Islam didasari oleh tiga asas utama iaitu Aqidah, Syariah dan Akhlak. Akidah atau dikenali juga sebagai Tauhid adalah suatu bidang ilmu yang menjelaskan tentang kewujudan Allah, Tuhan yang Esa, yang telah menciptakan seluruh alam ini. Dalam ilmu Akidah juga dibincangkan tentang keimanan, di mana umat Islam dituntut untuk meyakini setiap perbuatan dengan meletakkan tujuannya untuk mendapatkan keredhaan Allah. Syariah pula adalah bidang ilmu yang membincangkan tentang hukum sesuatu perbuatan atau tindakan. Akhlak pula membincangkan sesuatu bentuk tindakan yang baik daripada seseorang. Perbincangan berkaitan akhlak ini juga sama isinya dengan perbincangan ilmu tasawuf. Aktiviti yang melibatkan Syariah dan Akhlak memerlukan niat. Sekiranya seseorang mempunyai niat yang betul dan menepati syarak, maka tindakan yang dibuat akan berpahala. Hal ini menunjukkan niat sangat penting dalam aktiviti kehidupan seseorang Muslim. Wahbah az-Zuhaili (2010) menjelaskan niat sebagai satu pekerjaan hati yang mengarahkan seseorang Muslim untuk membuat kebaikan atau keburukan. Pendapat Wahbah az-Zuhaili ini mempunyai sokongan yang kukuh, di mana terdapat hadis yang diriwayatkan oleh Saidina Umar al-Khatab yang bermaksud, "...*setiap perbuatan itu adalah bergantung kepada niat...*" (Sahih al-Bukhari, no. Hadith 1).

3.0 DEFINISI NIAT DARIPADA PERSPEKTIF ISLAM

Al-Nawawi, (1989) mendefinisi niat dari sudut bahasa sebagai "*qasad*" (*tujuan hati*) dan "*iradah*" (kehendak hati). Menurut istilah syarak pula, niat adalah tergeraknya hati untuk melakukan sesuatu tindakan yang baik dengan tujuan untuk mendapatkan keredhaan dan mentaati perintah Allah (Al-Nawawi, 1989). Al-Ghazali (1981) pula menyatakan bahawa perkataan niat yang mengandungi dua maksud iaitu *iradah* (kehendak hati) dan *qasad* (tujuan hati) merupakan istilah yang mempunyai pengertian yang sama. Niat menurut pandangan ulama fiqh

pula ialah setiap perbuatan yang beriringan dengan “*qasad*” atau kehendak (Al-Nawawi, 1989). Menerusi definisi-definisi ini, jelas bahawa niat merupakan suatu tujuan dan kehendak bagi seseorang melakukan sesuatu tindakan kerana Allah, atau disebutkan juga sebagai ikhlas dalam segala tindakan yang dilakukan. Kenyataan tindakan bertujuan kerana Allah atau disebut sebagai ikhlas ini turut disokong oleh Al-Nawawi (1989), Al-Ghazali (1981) serta Mustafa dan Muhyidin (2016). Oleh yang demikian, niat di dalam Islam perlulah berpaksikan kepada tujuan baik yang menepati syarak, agar segala tindakan yang dilakukan oleh seseorang adalah ikhlas dan diterima di sisi Allah SWT. Walaupun niat itu boleh juga mendorong seseorang kepada tindakan jahat, tetapi Islam menghendaki agar umat Islam sentiasa memperbaiki niatnya agar bertepatan dengan syarak dalam mematuhi segala perintah Allah SWT terhadap hamba-hamba-Nya. Zeinab (n.d.) telah membawa tiga definisi niat menurut bahasa iaitu pertama niat adalah sesuatu yang timbul dalam fikiran seseorang. Kedua niat adalah motif dalaman yang membezakan antara satu perbuatan dengan perbuatan yang lain iaitu satu perbuatan dibuat kerana Allah, manakala satu lagi dibuat bukan kerana Allah. Terakhir, niat didefinisikan sebagai sesuatu yang sama dengan keinginan dan harapan untuk bertindak. Definisi kedua di atas adalah definisi menurut termonologi Islam, iaitu niat merupakan pembuktian ketaatan seseorang dalam mematuhi setiap perintah dan larangan Allah serta mengharapkan keredhaanNya. Kesimpulannya, definisi yang dijelaskan ini dapat difahamkan bahawa niat adalah lintasan fikiran seseorang untuk melakukan sesuatu tindakan bertujuan kerana Allah.

4.0 SUMBER ILMU NIAT DALAM ISLAM

Sumber ilmu berkaitan niat daripada perspektif Islam adalah berpandukan al-Quran, Hadis dan ijma' ulama'. Niat telah disebutkan sama ada secara tersurat atau tersirat di dalam beberapa ayat al-Quran dan juga hadis. Wahbah az-Zuhaili (2010) dan Muhammad (2003) menyatakan penjelasan berkaitan niat di dalam al-Quran yang tidak semuanya menggunakan perkataan “*al-niyyah*”, tetapi perkataan yang digunakan membawa maksud sama dengan “*al-niyyah*”. Antara perkataan yang digunakan bagi menggambarkan bahawa ianya bermaksud niat adalah seperti perkataan ikhlas, *al-iradah*, *ibtigha mardatillah* (menuntut keredhaan Allah), *ibtigha wajhillah* serta *ihtisab* dan lain-lain (Muhammad, 2003; Abdul Hayei, 1995). Contohnya sebagaimana yang terdapat di dalam ayat-ayat berikut:

“dan bandingan orang-orang yang membelanjakan hartanya kerana mencari keredaan dan kerana meneguhkan (iman dan perasaan ikhlas) yang timbul dari jiwa mereka” (Al-Baqarah 2: 65)

Allah tidak mengira kamu bersalah tentang sumpah kamu yang tidak dimaksudkan (untuk bersumpah), tetapi Ia mengira kamu bersalah (dan akan mengenakan hukuman) dengan sebab sumpah yang diusahakan (disengajakan) oleh hati kamu (dengan niat bersumpah). Dan (ingatlah), Allah Maha Pengampun, lagi Maha Penyabar. (Al-Baqarah 2:225)

“...dan kamu pula tidaklah mendermakan sesuatu melainkan kerana menuntut keredhaan Allah” (Al-Baqarah 2: 272)

Katakanlah (wahai Muhammad): "Jika kamu sembunyikan apa yang ada dalam dada kamu atau kamu melahirkannya, nescaya Allah mengetahuinya; dan Ia mengetahui segala yang ada di langit dan yang ada di bumi. Dan Allah Maha Kuasa atas tiap-tiap sesuatu. (Ali- 'Imran 3:29)

“... dan janganlah engkau usir orang-orang yang beribadat dan berdoa kepada Tuhan mereka pagi dan petang, sedang mereka menghendaki keredhaanNya semata-mata” (Surah Al-An'am 6:52)

Daging dan darah binatang korban atau hadiah itu tidak sekali-kali akan sampai kepada Allah, tetapi yang sampai kepadaNya ialah amal yang ikhlas yang berdasarkan taqwa dari kamu. Demikianlah Ia memudahkan binatang-binatang itu bagi kamu supaya kamu membesarkan Allah kerana mendapat nikmat petunjukNya. Dan sampaikanlah berita gembira (dengan balasan yang sebaik-baiknya) kepada orang-orang yang berusaha supaya baik amalnya. (Al-Hajj 22:37)

Pada hal mereka tidak diperintahkan melainkan supaya menyembah Allah dengan mengikhlaskan ibadat kepadaNya, lagi tetap teguh di atas tauhid; dan supaya mereka mendirikan sembahyang serta memberi zakat. Dan yang demikian itulah Agama yang benar. (Al-Bayyinah 98:5)

Sementara itu, hadis yang sering menjadi sumber utama dalam membicarakan mengenai niat adalah hadis yang diriwayatkan oleh Saidina Umar yang bermaksud,

“Daripada Amirul Mukminin Abu Hafs ‘Umar ibn al-Katthab r.a. beliau berkata: Aku mendengar Rasulullah SAW bersabda: Bahawa sesungguhnya setiap amalan itu bergantung kepada niat, dan bahawa sesungguhnya bagi setiap orang apa yang dia niatkan. Barangsiapa yang hijrahnya menuju kepada Allah dan RasulNya, maka hijrahnya kepada Allah dan RasulNya. Barangsiapa yang hijrahnya kerana dunia yang dia mahu mencari habuannya, atau kerana seorang perempuan yang dia mahu kahwininya, maka hijrahnya ke arah perkara yang ditujuinya itu”. [Sahih al-Bukhari, no. Hadith 1].

Hadis ini telah diriwayatkan oleh dua orang Imam Hadis iaitu Imam Bukhari dan Imam Muslim. Hadis ini dibahasakan dalam pelbagai bidang ilmu oleh ulama-ulama terkenal seperti Imam Al-Ghazali, Imam Nawawi, Imam As-Sayuti serta ulama-ulama semasa seperti al-Zuhaili dan al-Qardawi. Hadis ini amat penting untuk diberi perhatian dan diamalkan oleh seseorang Muslim. Hadis ini juga mempunyai nilai martabat yang tinggi kerana ianya menjadi rujukan bagi kebanyakan hukum dalam ajaran Islam (Al-Nawawi, 1989). Imam Abu Dawud telah menukilkan *“sesungguhnya hadis ini adalah separuh ajaran Islam”* (Abdul Hayei, 1995). Maksud *“...separuh ajaran Islam”* dirujuk kepada ajaran Islam terdapat dua bentuk amalan iaitu amalan zahir dan amalan batin. Ini menunjukkan niat adalah salah satu unsur yang sangat penting bagi menggerakkan seseorang untuk bertingkah laku.

Para ulama silam mahupun kini menyatakan bahawa hadis ini mengandungi sepertiga ilmu dalam kehidupan. Hal ini kerana setiap perbuatan seseorang individu itu adalah melibatkan hati, lidah dan anggota badan. As-Sayuti (1998) menjelaskan bahawa niat adalah dengan hati. Oleh itu, niat termasuk dalam salah satu daripada tiga bahagian utama dalam aktiviti kehidupan seseorang. Imam al-Baihaqi juga turut menerangkan bahawa sesuatu tingkah laku manusia itu mempunyai faktor yang menggerakkannya sama ada hati, lisan atau anggota badan (Wahbah az-Zuhaili, 2010). Selain itu, Imam Syafie menyatakan hadis niat adalah termasuk dalam 70 bab dalam ilmu Fiqah (Muhammad Idris, 2017), di samping ianya menjadi tajuk utama perbincangan dalam kitab beberapa orang ulama seperti Imam Bukhari dan Imam Nawawi (Al-Nawawi, 1989). Menurut Abdul Hayei (1995) tujuan Imam Bukhari dan Imam Nawawi meletakkan niat sebagai permulaan perbincangan di dalam kitab-kitab mereka adalah untuk mewujudkan rasa ikhlas di dalam hati bagi menyampaikan ilmu, serta untuk memperingati pembaca bahawa niat ikhlas adalah penting dalam setiap tindakan. Atas dasar itu, maka Imam Bukhari menjadikan hadis niat sebagai hadis nombor satu di dalam Kitab Sahih Bukhari (Mustafa & Muhyidin, 2016).

Di samping itu, terdapat juga hadis-hadis lain yang menyentuh tentang niat antaranya:

عَنْ ابْنِ الْوَلِيدِ بْنِ عُبَادَةَ بْنِ الصَّامِتِ، عَنْ جَدِّهِ قَالَ: قَالَ رَسُولُ اللَّهِ صَلَّى اللَّهُ عَلَيْهِ وَسَلَّمَ: «مَنْ غَزَا فِي سَبِيلِ اللَّهِ وَلَمْ يَتَوَّأْ إِلَّا عَقْلًا فَلَهُ مَا تَوَّأ»

“Dari Ubadah bin al-Samit r.a, daripada Rasulullah s.a.w. Sabdanya: Barangsiapa yang berperang di jalan Allah sedangkan dia tidak berniat demikian, melainkan untuk mendapat tali unta, maka baginya apa yang telah dia niatkan”. [al-Sunan al-Kubra Li al-Nasa’i, no. Hadith 4331].

عَنْ أَبِي هُرَيْرَةَ، قَالَ: قَالَ رَسُولُ اللَّهِ صَلَّى اللَّهُ عَلَيْهِ وَسَلَّمَ: «إِنَّمَا يُبْعَثُ النَّاسُ عَلَى نِيَّاتِهِمْ»

Abu Hurairah r.a menyatakan, Rasulullah s.a.w bersabda, “Sesungguhnya akan dibangkitkan manusia nanti selari dengan niat mereka”. [Sunan Ibn Majah, no. Hadith 4229].

Merujuk kepada maksud firman Allah dan hadis yang telah dinyatakan sebelum ini menggambarkan sesuatu perbuatan adalah berdasarkan niat seseorang. Niat adalah sesuatu yang tidak dapat dilihat tetapi mampu mempengaruhi kehidupan seseorang.

Tambahan lagi, sudah terdapat ramai ulama silam mahupun terkini yang membicarakan tentang niat. Imam Al-Ghazali misalnya telah membicarakan niat di dalam kitabnya yang bertajuk *“Ihya Ulumudin”* (Al-Ghazali, 1981). Demikian juga Imam Nawawi turut membicarakan tentang niat di dalam kitab-kitabnya seperti *“Riyadus Solihin”*, *“al-Adhkar”* dan *“al-Arba’in”*. Selain itu, ulama-ulama semasa seperti Wahbah al-Zuhaili dan Yusuff al-Qardawi turut membicarakan tentang niat. Dalam membicarakan tentang niat, Wahbah al-Zuhaili telah membincangkannya secara mendalam yang dimuatkan oleh beliau di dalam kitabnya yang bertajuk *Fiqh Islam Wa Adillatuhu* (Wahbah az-Zuhaili, 2010). Yusuff al-Qardawi turut membicarakan mengenai niat yang memberi fokus kepada aspek ibadat dan perjuangan menerusi bukunya yang bertajuk *al-Ikhlash wa al-Niyyah*. Merujuk kepada perbincangan ini, sumber niat daripada perspektif Islam adalah begitu jelas dan tetap iaitu daripada al-Quran dan hadis serta dihuraikan oleh para ulama sama ada dahulu mahupun kini.

5.0 KEPENTINGAN DAN FUNGSI NIAT DALAM ISLAM MEMPENGARUHI TINDAKAN SESEORANG

Merujuk kepada definisi yang telah dibincangkan oleh Al-Nawawi (1989) fungsi dan kepentingan utama niat adalah untuk melakukan sesuatu tindakan dengan tujuan ketaatan dan untuk mendapat keredhaan Allah. Al-Ghazali (1981) telah menyatakan niat merupakan pemandu arah kepada sesuatu perbuatan, di mana jika baik niat seseorang maka baiklah perbuatannya, dan sekiranya buruk niatnya, maka buruklah perbuatannya. Tambahan lagi, beliau menjelaskan sesuatu tindakan tanpa niat itu seperti suatu kerja yang tidak mempunyai tujuan. Niat yang dimaksudkan menerusi syarak adalah niat berbuat kebaikan kerana Allah, atau disebut juga sebagai niat yang ikhlas.

Niat yang ikhlas adalah penting kepada seseorang Muslim. Tindakan yang disertakan dengan niat yang ikhlas akan diganjar dengan pahala (Al-Ghazali, 1981). Dalam ajaran Islam, dosa dan pahala amat dititikberatkan demi kejayaan dunia dan akhirat (Abdul Hayie, 1995). Niat menjadi pendorong kepada seseorang Muslim untuk melakukan kebaikan. Dalam menentukan sesuatu perbuatan itu mendapat ganjaran pahala atau dosa, niat menjadi kayu ukurnya (Wahbah az-Zuhaili, 2010). Tambahan lagi, Al-Ghazali (1981) dan Al-Nawawi (1984) menyatakan niat lebih utama daripada tindakan. Sesuatu perbuatan baik yang disertakan niat kerana Allah akan diganjar dengan pahala. Terdapat keistimewaan tambahan menurut Islam tentang niat iaitu walaupun sesuatu kebaikan hanya diniatkan, tanpa dapat dilaksanakan kerana terdapat halangan tertentu, individu tersebut tetap akan diganjar dengan pahala atas niat yang baik itu (Al-Ghazali, 1981; Al-Nawawi, 1984). Hal ini adalah bersandarkan kepada hadis yang bermaksud, "*niat seseorang itu lebih baik daripada amalannya*" [Mu'jam al-Kabir Li al-Tabrani, no. Hadith 5942]. Para imam mujtahidin berpendapat bahawa sesuatu amal ibadah itu sah dan diterima serta dianggap sempurna apabila disertai dengan niat (Al-Nawawi, 1984).

Selain niat penting untuk diganjar dengan pahala, niat juga berperanan untuk memenuhi kehendak dalam membuat perancangan serta keputusan. Zahra, Mohammed Hassan dan Abolfazl (2016) menjelaskan bahawa niat berperanan untuk membentuk kehendak yang tepat, iaitu setiap kehendak perlulah diletakkan tujuan yang betul. Hal ini di mana setiap tindakan atau perbuatan seorang Muslim adalah untuk mentaati dan mendapat keredhaan Allah. Misalnya, dalam memenuhi kehendak untuk mengambil makanan, seseorang Muslim yang mempunyai niat yang betul kerana Allah tidak akan mengambil sesuatu yang haram dan berlebihan. Muhammad (2003) pula berpendapat setiap tindakan perlu bermula dengan perancangan, dan perancangan inilah yang dianggap sebagai niat.

Al-Nawawi (1989) menegaskan bahawa niat dalam Islam menjadi pembeza antara ibadat dan adat. Contohnya mandi sebagai rutin harian hanya dikira adat apabila dilakukan untuk membersihkan badan semata-mata. Namun dengan berniat mandi sunat hari Jumaat, mandi yang sama bertukar menjadi ibadah kerana membersihkan badan disertai dengan niat sunat hari Jumaat. Begitu juga seseorang yang masuk ke dalam masjid semata-mata untuk berehat tidak mendapat pahala ibadat iktikaf sekiranya tidak disertai dengan niat iktikaf. Selain itu, niat juga berperanan membezakan antara jenis ibadat itu sendiri. Misalnya, dalam membezakan puasa sunat hari Isnin dan puasa wajib di bulan Ramadhan adalah dengan niat.

Justeru, tidak hairanlah terdapat penulisan berkisar tentang niat bukan hanya dalam ruang lingkup ibadat khusus seperti solat, puasa, haji serta zakat, malah turut dibincangkan dalam ruang lingkup muamalat seperti akad jual beli, hibah, kifalah, hiwalah dan lain-lain. Niat juga dibincangkan dalam perihal *fasakh*, *al-tark* atau perkara-perkara yang dituntut ditinggalkan seperti meninggalkan benda yang haram, menghilangkan najis, mengembalikan barang pinjaman dan lain-lain (Wahbah az-Zuhaili, 2010; Muhammad Idris, 2017).

Selanjutnya Wahbah az-Zuhaili (2010) menghuraikan pandangan Imam al-Baihaqi yang berpendapat bahawa sesuatu tingkah laku manusia mempunyai faktor-faktor yang menggerakkannya. Faktor-faktor penggerak itu sama ada hati, lisan atau anggota badan. Hati yang dimaksudkan di sini boleh difahami sebagai niat kerana niat terletak di hati. Imam As-Sayuti mengemukakan kaedah fiqh yang berbunyi: "*al-umurbi maqashidih*" iaitu segala sesuatu termasuklah tingkah laku adalah bergantung kepada tujuan atau niatnya. Berdasarkan pendapat Imam al-Baihaqi dan Imam As-Sayuti ini menunjukkan bahawa dalam Islam terdapat amalan lahiriah dan amalan batiniah. Perbuatan secara batiniah inilah niat (Wahbah az-Zuhaili, 2010). Selanjutnya, perbincangan diteruskan dengan penerangan mengenai niat dalam ibadat khusus dan perkara mubah.

6.0 NIAT DALAM IBADAT KHUSUS DAN PERKARA MUBAH

Perbincangan niat dalam Islam adalah menyeluruh dalam semua tindakan, meliputi permasalahan ibadat wajib, ibadat sunat serta perbuatan mubah. Seperti yang dibincangkan sebelum ini, niat mempunyai sumber ilmu yang jelas dan terperinci, terutamanya dalam perihal ibadat wajib.

Wahbah az-Zuhaili (2010) menghuraikan bahawa Jumhur fuqaha, kecuali Mazhab Hambali menyatakan niat dalam ibadat-ibadat khusus seperti wudhu, solat, puasa, haji dan lain-lain adalah wajib hukumnya. Oleh yang demikian, sesiapa sahaja yang melakukan ibadah tanpa niat, maka ibadahnya adalah sia-sia serta tidak sah. Sebaliknya dalam perbuatan-perbuatan mubah atau aktiviti-aktiviti harian seperti makan, minum, tidur dan lain-lain adalah sunat diniatkan kerana Allah. Kesimpulannya, setiap perbuatan yang mubah jika dilakukan dengan mematuhi garis panduan yang telah ditetapkan oleh syarak dan diniatkan kerana Allah, akan dikira sebagai ibadah dan mendapat ganjaran pahala (Wahbah az-Zuhaili, 2010; Al-Habib Sa'd Muhammad, 2017). Penjelasan ini seiring dengan maksud hadis yang diriwayatkan oleh Saidina Umar,

“Sesungguhnya amal perbuatan adalah bergantung kepada niatnya, dan seseorang akan mendapat sesuatu yang sesuai dengan niatnya”. [Sahih al-Bukhari, no. Hadith 1]

Wahbah az-Zuhaili (2010) mengatakan bahawa seorang Muslim seharusnya melakukan sesuatu perkara mubah seperti makan, minum, tidur dan lain-lain berpandukan kepada garis panduan syarak dan disertakan dengan niat untuk mendapat redha dan mentaati Allah. Wahbah az-Zuhaili (2010) menjelaskan lagi, dewasa ini seorang Muslim yang mentaati dan meninggalkan larangan Allah, masih ada yang bersikap lalai dengan tidak mengaitkan perbuatan mubah sebagai ibadah kepada Allah. Selain itu, terdapat juga Muslim yang bertindak melakukan sesuatu hanya bertujuan untuk memenuhi keperluan atau kehendak peibadi semata-mata tanpa mengaitkannya dengan usaha untuk mentaati Allah. Terdapat juga individu yang bertindak secara berlebihan serta melanggar hukum hakam syarak. Misalnya dalam aktiviti makan, seseorang itu hanya sekadar makan bagi memenuhi tuntutan perutnya sahaja tanpa berniat makan itu kerana Allah, bahkan terdapat juga Muslim yang berlebihan dalam mengambil makanan sehinggakan terjebak dengan pembaziran yang dilarang oleh agama.

Walaupun para ulama menyatakan perbuatan mubah itu tidak memerlukan niat kerana ianya tidak melibatkan sah atau tidaknya sesuatu perbuatan, tetapi Al-Ghazali (1981) dan Wahbah az-Zuhaili (2010) mengingatkan bahawa niat adalah penting dalam perbuatan mubah bagi mengubah sesuatu perbuatan mubah itu menjadi ibadah serta memperolehi pahala. Perbuatan yang disertai niat boleh mendekatkan diri seseorang kepada Allah (Al-Ghazali, 1981) serta berpahala walaupun pada asalnya ianya hanya dalam kategori mubah sahaja. Huraian ini selari dengan kata-kata para sahabat Rasulullah s.a.w yang menyatakan,

“sesungguhnya aku menyukai bahawa adalah bagiku niat pada setiap sesuatu, sehingga makanku, minumku, tidurku dan masukku ke baitul-khala’ (tempat tidur) dan banyaklah amalan yang kecil, dibesarkan oleh niat, dan banyak amalan yang besar, dkecilkan oleh niat” (Al-Ghazali, 1981).

Terdapat juga sabda Rasulullah s.a.w yang bermaksud, *“niat orang mukmin itu lebih baik dari amal perbuatannya”* [Mu‘jamal-Kabir Li al-Tabrani, no. Hadith 5942].

Kata-kata sahabat Rasulullah dan pernyataan sebahagian ulama ini menggambarkan bahawa niat yang baik kerana Allah amat digalakkan dalam perbuatan mubah, walaupun niat tidak diperlukan dalam perbuatan mubah kerana ianya tidak melibatkan sah atau tidak perbuatan tersebut.

Berdasarkan perbincangan ini, walaupun niat tidak penting atau tidak diperlukan dalam perbuatan mubah atau harus, namun sekiranya seseorang Muslim menyertakan niat kerana Allah dalam perbuatan hariannya misalnya dalam kepenggunaan adalah tidak merugikan sama sekali, bahkan akan mendatangkan kebaikan dan manfaat kepadanya untuk dunia dan akhirat. Perbincangan seterusnya, berkaitan faktor-faktor yang mempengaruhi niat dalam sesuatu tindakan.

7.0 NIAT DALAM KEPENGGUNAAN

Sebagaimana yang telah dibincangkan di atas, para ulama telah menjelaskan niat dalam ibadah khusus dan perbuatan mubah. Perbuatan mubah merupakan perkara yang termasuk dalam ibadah umum. Kepenggunaan adalah perbuatan mubah yang diberi keluasan yang amat luas kepada manusia untuk menentukan dan melaksanakan bagi memenuhi kehendak dan keperluan hidup mereka. Antara perbuatan dalam kepenggunaan adalah memasar dan berbelanja.

Kepenggunaan didefinisikan sebagai segala perihal mengenai pengguna (Kamus Dewan, 2015) Tujuan utama kepenggunaan adalah untuk menjaga kepentingan serta memberi pendidikan kepada pengguna (Mohd Anuar & Mohammad Aizat, 2011). Mohd Hamdan (1994) pula menyatakan terdapat pelbagai takrifan dan tujuan kepenggunaan, namun pada asasnya ia adalah berkaitan perihal pengguna dan bertujuan untuk melindungi hak pengguna. Kepenggunaan bertujuan memastikan pengguna dilindungi dan menerima tawaran yang adil.

Pendidikan dan undang-undang kepenggunaan adalah untuk memastikan pengguna mendapatkan produk atau perkhidmatan yang baik dan memuaskan, namun tidak semestinya semua kehendak pengguna perlu dipenuhi (Mann & Thornton, 1978).

Yusuf Al-Qardawi (2009), Nursuhaida dan Siti Zaiton (2012) pula menerangkan aktiviti kepenggunaan daripada perspektif Islam. Kepenggunaan daripada perspektif Islam adalah satu amanah dan ketentuan daripada Allah, setiap perbuatan adalah perlu mematuhi hukum yang telah dijelaskan. Misalnya dalam pengambilan makanan perlu memilih makanan yang halal. Di samping itu, kemampuan memiliki sesuatu bukan hanya untuk diri sendiri, tetapi untuk dikongsi bersama orang lain, pada masa yang sama amalan berlebih-lebihan atau kedekut amat ditegah. Ajaran Islam menggalakkan umatnya berbuat kebaikan dan meninggalkan keburukan seperti, membantu golongan miskin dan berpendapatan rendah, melarang pembaziran, melarang mengambil dan menggunakan barangan haram dan lain-lain.

Niat turut ditekankan dalam Islam. Yusuf Al-Qardawi (2009) menegaskan bahawa niat atau tujuan kepenggunaan seorang Muslim adalah untuk mendapatkan keredhaan Allah. Misalnya niat membeli makanan adalah untuk memenuhi keperluan diri bagi mendapatkan tenaga yang diperlukan untuk bekerja dan beribadat semata-mata kerana Allah.

8.0 FAKTOR MEMPENGARUH NIAT DALAM AKTIVITI KEPENGGUNAAN

Dalam karya-karya lepas, didapati al-Ghazali membincangkan niat dengan agak terperinci. Beliau telah mengemukakan pandangan tentang faktor yang mempengaruhi niat. Menurut Al-Ghazali (1981), sesuatu tindakan dipengaruhi oleh niat, manakala niat pula dipengaruhi oleh pengetahuan. Penjelasan hubungan antara tindakan, niat dan pengetahuan ini adalah merujuk kepada ulasan beliau iaitu,

Dan anggota badan itu tidak bergerak, selain dengan kemampuan (qudrah). Dan qudrah itu menunggu pengajak yang membangkitkan. Dan pengajak itu menunggu ilmu dan ma'rifah atau sangkaan (dhann) dan ittihad (tekad). Yaitu, bahawa ia menguatkan pada dirinya, bahawa keadaan sesuatu itu bersesuaian baginya. Maka apabila ma'rifah itu yakin, bahawa sesuatu itu bersesuaian dan tidak boleh tidak bahawa diperbuatnya dan ia selamat dari rintangan pembangkit lain, yang memalingkan daripadanya, niscaya membangkitkanlah kehendak dan terbuktiilah kecenderungan. Maka apabila membangkitkanlah kehendak (niat), niscaya terbangunlah kemampuan bagi menggerakkan anggota-anggota badan (Al-Ghazali, 1981:62).

Penjelasan ini juga boleh digambarkan seperti dalam Rajah 1.

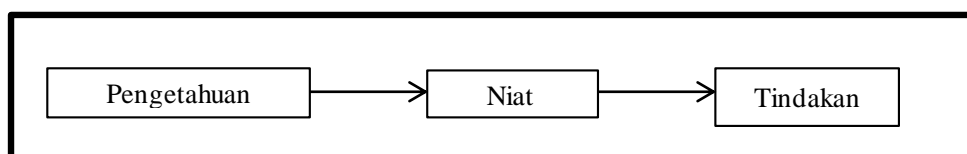

Rajah 1: Rumusan perbincangan niat mempengaruhi tindakan oleh Imam Al-Ghazali.

Misalnya, seorang Muslim yang bermusafir ke negara bukan Islam yang mengetahui ciri-ciri makanan halal, serta mengetahui kewajiban memilih makanan halal akan berusaha mencarinya. Namun sebaliknya, seorang Muslim yang tidak tahu ciri-ciri makanan halal, pasti memilih makanan yang tersedia di pasaran tanpa membuat pertimbangan halal haram, kerana dia tidak mengetahui ciri-ciri makanan halal. Oleh yang demikian, pengetahuan amat penting bagi mendorong niat yang baik dalam mentaati segala perintah Allah SWT. Pengetahuan merupakan kunci utama dalam mentaati perintah Allah, manakala niat sebagai penggerak kepada sesuatu tindakan, dan tindakan yang dilakukan pula sebagai pelaksana terhadap tuntutan hati yang dipengaruhi oleh ilmu pengetahuan terhadap agama.

9.0 JENIS NIAT DAN KAITANNYA DENGAN TINDAKAN SESEORANG

Al-Ghazali (1981) telah membahagikan niat kepada empat jenis, iaitu niat yang murni atau ikhlas, niat berteman, niat perkongsian dan niat bertolong-tolongan. Setiap niat ini dibezakan dengan situasi faktor yang mempengaruhi tindakan seseorang. Al-Ghazali (1981) turut menjelaskan hanya niat yang murni sahaja yang diiktiraf sebagai niat yang ikhlas. Misalnya, Ahmad telah bersarapan pagi untuk mendapatkan tenaga bagi menjalankan tugas hariannya kerana Allah. Sehubungan dengan itu, niat yang ikhlas adalah sangat penting dalam sesuatu tindakan yang dibuat, serta pengetahuan terhadap niat yang tidak ikhlas pula bagi mengelak dari melakukan sesuatu

perbuatan dengan sia-sia tanpa memperoleh pahala. Sebab itulah, al-Ghazali membahagikan niat kepada beberapa jenis agar umat Islam dapat membezakan antara niat ikhlas dan tidak ikhlas, moga mereka tidak terjebak dengan niat yang tidak berfaedah.

Niat murni (*niyyatun khaalishatun*) ialah sesuatu perbuatan yang dilakukan dengan satu faktor utama tanpa dipengaruhi oleh faktor lain (Al-Ghazali, 1981). Misalnya seseorang bersedekah kerana manfaat bersedekah yang diketahuinya, bukan kerana faktor lain. Contoh lain ialah, seseorang memilih makanan halal bukan kerana faktor terpengaruh dengan orang sekeliling atau bukan kerana kemampuannya untuk mendapatkan makanan tersebut, namun pilihan dibuat kerana dia mengetahui bahawa sebagai seorang Muslim wajib baginya memilih makanan halal untuk mentaati perintah dan mendapat keredhaan Allah. Kesimpulannya, niat pertama ini adalah niat untuk bertingkah laku hanya kerana Allah semata-mata tanpa dipengaruhi oleh faktor-faktor lain. Mujiburrahman (2011) juga turut menyatakan bahawa niat jenis pertama yang dijelaskan oleh al-Ghazali ini membawa maksud niat ikhlas. Niat jenis yang pertama ini juga sangat terkait dengan pengetahuan agama seseorang, sebagaimana yang dibincangkan oleh al-Ghazali sebelum ini. Dengan erti kata lain, jika seseorang itu tidak mempunyai ilmu pengetahuan agama yang kukuh, maka agak sukar untuk memulakan niat yang murni bagi mentaati perintah Allah SWT.

Niat kedua adalah niat berteman. Niat ini mempunyai dua faktor mempengaruhinya. Misalnya, seseorang Muslim memilih makanan halal kerana mengetahui kewajipannya sebagai Muslim. Pada masa sama, dia terpengaruh dengan persekitaran sekeliling dalam memilih makanan halal. Walaupun pada dasarnya dia tetap akan memilih makanan halal dalam apa jua keadaan sekeliling, namun Al-Ghazali (1981) berpendapat niat ini tidak diiktiraf sebagai niat yang ikhlas kerana kehadiran faktor lain mempengaruhi tindakannya. Hal ini dilihat kepada sikap seseorang yang tidak mempunyai ilmu pengetahuan agama yang kukuh, tetapi dipengaruhi oleh persekitaran. Disebabkan individu itu berada dalam kalangan masyarakat Muslim yang melakukan ketaatan kepada Allah, maka individu itu dengan sendirinya turut mengikut apa yang dilakukan oleh masyarakat Muslim, walaupun tiada pengetahuan asas bagi menjunjung perintah Allah SWT. Sebaliknya, individu yang sama jika berada dalam masyarakat yang ramai ingkar kepada perintah Allah, maka individu berkenaan akan terpengaruh dengan perbuatan ingkar masyarakat. Amalan individu sebegini tidak didorong oleh niat yang ikhlas, tetapi hanya dipengaruhi oleh persekitaran semata-mata.

Niat seterusnya dikenali sebagai perkongsian, iaitu niat terbentuk oleh dua faktor yang saling mempengaruhinya. Misalnya, seorang Muslim memilih makanan halal kerana terdapat logo halal, dan keluarganya turut memilih produk tersebut. Sebaliknya, sekiranya makanan itu tidak mempunyai logo halal atau keluarganya tidak memilih, maka dia tidak memilih makanan tersebut. Kesimpulannya, individu tersebut tidak akan memilih makanan halal tersebut sekiranya dua faktor yang mempengaruhi pilihannya tidak wujud. Niat jenis ini sama seperti niat jenis kedua, dipengaruhi oleh orang lain. Perbezaan antara niat jenis kedua dan ketiga ialah niat jenis kedua dipengaruhi oleh persekitaran, manakala niat jenis ketiga dipengaruhi oleh ahli keluarga terdekat. Kesemua ini berpunca daripada ilmu pengetahuan agama yang tidak kukuh pada diri seseorang.

Jenis niat terakhir adalah bertolong-tolongan. Terdapat dua faktor yang mempunyai kekuatan berbeza mempengaruhi niat ini. Iaitu, faktor kuat dan faktor lemah. Faktor kuat mampu berdiri dengan sendiri dalam mempengaruhi niat, dan hadirnya faktor lemah mampu memperkuatkannya lagi. Sebaliknya faktor lemah tidak dapat berdiri dengan sendirinya. Misalnya, Abu sebagai seorang pensyarah bersama pelajar-pelajarnya telah terlibat dalam satu lawatan ke salah sebuah negara bukan Islam dan agak susah untuk mendapatkan makanan halal. Abu tetap berusaha memilih makanan halal walaupun agak susah, tambahan lagi beliau merasakan tanggungjawabnya untuk menunjukkan teladan baik kepada para pelajar. Dalam situasi ini, Abu adalah faktor kuat di mana beliau tetap berusaha mendapatkan makanan halal walaupun di negara bukan Islam. Faktor lemah pula merujuk kepada para pelajar yang kemungkinan tidak akan berusaha untuk mendapatkan makanan halal di negara tersebut tanpa bimbingan Abu. Walaupun niat Abu berusaha mendapatkan makanan halal kerana Allah, namun masih tidak dapat dinyatakan ikhlas kerana masih dipengaruhi oleh keberadaan para pelajarnya. Tindakan Abu juga didorong oleh perasaan tanggungjawab untuk mendapatkan makanan halal kepada para pelajarnya. Dorongan yang kuat di sini ialah para pelajarnya. Sekiranya para pelajarnya tiada, kemungkinan dorongan tersebut tidak sekuat itu.

Kesimpulan daripada kesemua jenis niat ini, bukan mudah untuk seseorang Muslim ingin mencapai niat ikhlas. Merujuk kepada penjelasan Al-Ghazali (1981) hanya niat jenis pertama, iaitu niat murni sahaja dikatakan sebagai niat ikhlas. Berdasarkan pendapat Al-Ghazali (1981) ini, dalam isu kepenggunaan, keikhlasan seseorang itu amat sukar untuk diperolehi kerana ia melibatkan hati seseorang yang hanya diketahui oleh Allah SWT. Ikhlas menurut al-Ghazali mestilah tidak dipengaruhi oleh sebarang pendorong melainkan hanya kerana Allah SWT. Oleh yang demikian, seseorang yang membeli sesuatu produk kerana jenama produk itu, kerana orang ramai yang

membeli, kerana harga, dan sebagainya yang tidak dikaitkan dengan ketaatan kepada Allah SWT, maka tindakan itu tidak dikira ikhlas. Ianya juga tidak termasuk ibadah, tetapi dalam kategori mubah sahaja yang tidak berpahala dan tidak berdosa perbuatan itu.

Namun, sekiranya seseorang itu membeli sesuatu produk kerana Allah seperti mentaati perintah Allah SWT agar mendapatkan produk yang halal, membantu ekonomi umat Islam, bersedekah, berwakaf, membantu keselesaan amal ibadah, membantu orang lain dalam kesusahan, dan seumpamanya maka ianya akan merubah daripada tindakan mubah kepada ibadah yang diperolehi pahala dengannya serta ikhlas kepada Allah SWT. Walaupun hal yang dilakukan itu hanyalah tindakan membeli produk sama seperti orang lain, tetapi disebabkan ianya didorong oleh perkara-perkara yang disebutkan itu, maka ianya merupakan tindakan yang berpahala dalam kepenggunaan. Oleh yang demikian, inilah yang membezakan antara niat kepenggunaan berdasarkan Islam dan Barat yang mana Islam menekankan aspek keikhlasan dalam segala tingkah laku, berbanding Barat yang hanya sekadar mengkaji niat dari sudut faktor, pengaruh dan sebagainya, tiadanya unsur keikhlasan, pahala dan ibadah seperti yang terdapat di dalam ajaran Islam. Sepatutnya, para pengkaji Muslim kini yang ingin mengkaji mengenai niat dalam kepenggunaan, tidak boleh mengabaikan sama sekali niat menurut Islam, lalu hanya bergantung kepada teori Barat semata-mata, kerana niat menurut Islam memberi nilai tambah dalam aktiviti kepenggunaan itu sendiri sama ada dari aspek dunia mahupun akhirat. Islam menekankan sajal mendidik masyarakat dalam kepenggunaan, berbanding Barat yang hanya menekankan aspek keuntungan duniawi semata-mata.

10. KESIMPULAN

Niat dalam kepenggunaan boleh disimpulkan sebagai tujuan seseorang memilih, membeli atau menggunakan sesuatu barang atau perkhidmatan. Keikhlasan dalam kepenggunaan boleh dicapai apabila seseorang menetapkan hatinya mendapatkan sesuatu produk atas dasar mematuhi perintah Allah serta meninggi kalimah Allah. Tujuan kemanusiaan yang berpaksikan akidah tauhid seperti membeli untuk membantu orang lain adalah menetapi konsep ikhlas dalam kepenggunaan. Mengutamakan produk Muslim yang halal juga selari dengan niat untuk meninggi kalimah Allah dan syiar Islam serta membantu mengukuhkan ekonomi umat Islam. Justeru, niat dalam kepenggunaan mampu memberi implikasi kepada gelagat pengguna Muslim. Pengguna Muslim sewajarnya menyedari kepentingan keikhlasan dalam kepenggunaan dan menetapkan niat yang ikhlas kerana Allah dalam hal yang bersangkutan dengan kepenggunaan.

RUJUKAN

- Abdul Hayei, A. S. (1995). Ulasan dan Terjemahan Hadith 40, Jilid 1 (Pertama). Dewan Bahasa dan Pustaka.
- Abu Zakaria Yahya ibn Sharaf Al-Nawawi. (1984). Riyadhus Shalihin Taman kaum Shalihin dari sabda Penghulu sekalian Rasul (R. M. Abdai (Ed.)). Singapura Pustaka Nasional.
- Al-Ghazali. (1981). Ihya' Ulumiddin atau Mengembangkan Ilmu-ilmu Agama (Tk. H. Ismail Yakub (Ed.)). Singapura Pustaka Nasional.
- Al-Habib Sa'd Muhammad, 'Alawi ai-Idrus al-Hadrami. (2017). Kitab al-Niyat. Dar al-Salih.
- Al-Nawawi. (1989). Hadith 40 (Terjemahan dan Syarahnya) (A. R. Mustafa (Ed.)).
- Al-Sunan al-Kubra Li al-Nasa'i
- As-Sayuti, A. H. S. J. A. R. (1998). Hadis-hadis Pilihan (H. Z. Haji Ahmad Wan Besar (Ed.)). Annasyir Sdn.Bhd.
- Kamus Dewan. (Edisi Keempat). (2015). Kuala Lumpur: Dewan Bahasa dan Pustaka.
- Mann, J., & Thornton, P. (1978). Consumerism in perspective. *European Journal of Marketing*, 12(4), 253–263. <https://doi.org/https://doi.org/10.1108/EUM000000004986>
- Mohd Anuar, R., & Mohammad Aizat, J. (2011). Pengenalan Kepenggunaan Islam. In A. Rahman Suhaimi & J. Mohammad Aizat (Eds.), Halal Haram dalam kepenggunaan Islam Semasa (Pertama, pp. 1–5). Universiti Putra Malaysia.
- Mohd Hamdan, A. (1994). Konsep Asas Kepenggunaan. Dewan Bahasa dan Pustaka.
- Muhammad, A. R. (2003). Sumbangan Syekh Idris al-Marbawi : Suatu Kajian terhadap Kitabnya Bahr al-Mazi, Tumpuan kepada Bab Niat. Universiti Malaya.
- Muhammad Idris, A.-M. (2017). Bahru Al-Madzi Sharah Mukhatashar Shahih At-Tirmidzi (Juzu' 1). Selangor: Al-Hidayah Publications.
- Mujiburrahman. (2011). Fenomenologi Niat. *Kanz Philosophia*, 1(2), 215–226.
- Mustafa, A.-B., & Muhyidin, M. (2016). Syarah Hadis 40 Imam Nawawi (A. F. Omar & A. Hasan (Eds.); Pertama). Pustaka Salam.
- Nurshuhaida, R. A., & Siti Zaiton, M. D. (2012). Perbezaan Analisis Kepenggunaan Menurut Ekonomi Konvensional dan Ekonomi Islam. *Prosiding Perkem VII*, 2, 1461–1470.
- Sunan Ibn Majah
- Wahbah az-Zuhaili. (2010). Fiqih Islam Wa Adillatuhu (A. H. Al-Kattani (Ed.); Pertama). Darul Fikir.
- Zahra, S. al-D., Mohammed Hassan, R., & Abolfazl, G. (2016). The Role of Intention in Spirituality in Terms of Islamic Texts and Positive-oriented Psychology. *Mediterranean Journal of Social Sciences*, 7(3). <https://doi.org/10.5901/mjss.2016.v7n3s2p15>
- Zeinab, H. A. (n.d.). *Our Deeds Sincerity*. Kuwait: IPC Islam Presentation Committee, Retrieved Januari 2019, from https://www.muslim-library.com/dl/books/English_OUR_DEEDS_and_Sincerity.pdf

MEASURING THE FINANCIAL INCLUSION: EVIDENCE FROM OIC COUNTRIES

Shahida Shahimi^a, Azrina Abdullah Al-Hadi^b, Abd Ghafar Ismail^c and Nurul Wafa' Mohd Bohari^d

^{a, b, d} Faculty of Economics and Management,
Universiti Kebangsaan Malaysia (UKM), Selangor, Malaysia
^c Faculty of Economics and Muamalat,
Universiti Sains Islam Malaysia (USIM), Selangor, Malaysia

Abstract

Financial inclusion is a situation when all players in the economy have equal access to formal financial services that meet their needs such as transactions, payments, savings and borrowings. The degree of financial inclusion is determined by three dimensions: access, usage and quality of the financial services. Different methods of measuring financial inclusion have been developed to understand the extend of financial inclusion among countries, resulting to diverse degrees of financial inclusion. It is suggested to use the multidimensional index. Thus, this study attempts to measure financial inclusion levels across 32 OIC countries in 2014 and 2017 using demand-side data survey (World Bank's Global Financial Inclusion) and supply-side data survey (International Monetary Fund's Financial Access Survey). The result provides evidence that high income and upper middle income countries have higher level of financial inclusion as compared to lower middle income and low income countries. The finding offers policy recommendation for the authorities in the lower middle income and low income OIC countries to provide conducive environment for the increasing economic growth and financial sector development. With robust strategies, financial inclusion will be able to economically and socially empower and uplift the quality of life of the underprivileged Muslims in OIC countries, thus meet the target of 'Leave No One Behind' of Agenda 2030.

Keywords: financial inclusion, measurement, index, OIC countries

1.0 INTRODUCTION

In recent decades, financial inclusion has been emerged as a trending topic for discussion among researchers, politicians, policymakers and other financial stakeholders all over the world. It has become a global agenda as many evidences from practical experiences and researches reveal that financial inclusion has a far-reaching impact on economic and social improvement hence contributes to achieving the Sustainable Development Goals. Financial inclusion, refers to "individuals and businesses have access to useful and affordable financial products and services that meet their needs - transactions, payments, savings, credit and insurance - delivered in a responsible and sustainable way" (World Bank, n. d.). Thus, in other words, people who have no access or limited access to normal financial services are considered as financially excluded.

Many countries in the world are suffering from financial exclusion especially in Muslim countries. As supported by Figure 1, about 45.12% of adults in Organization of Islamic Cooperation (OIC)⁶⁴ countries have an account in formal financial institutions⁶⁵, which is below the world average of 68.50% in 2017. The hindrance in the way of financial inclusion in OIC countries happens because of the religious reason as based on a 2010 Gallup poll, about 90% of the adults living in OIC countries recognize religion as important part of their lives (Crabtree, 2010). Thus, in OIC countries like Turkey and Pakistan, the percentage of adults with no account in formal financial institutions for religious reasons stands at 19% and 13% respectively, above the world average of 6% (Demirguc-Kunt, Klapper, Singer, Ansar, & Hess, 2018). This explains the religious prohibition of interest for not holding the conventional account causes Muslims do not have access toward financial services.

⁶⁴ The Organization of Islamic Cooperation (OIC) is an international organization founded in 1969, consisting of 57 member states. The organization is the collective voice of the Muslim world. It endeavours to safeguard and protect the interests of the Muslim world in the spirit of promoting international peace and harmony among various people of the world.

⁶⁵ Account (% age 15+) means 'the percentage of respondents who report having an account (by themselves or together with someone else) at a bank or another type of financial institution (credit union, microfinance institution, cooperative or the post office) or report personally using a mobile money service in the past 12 months.'

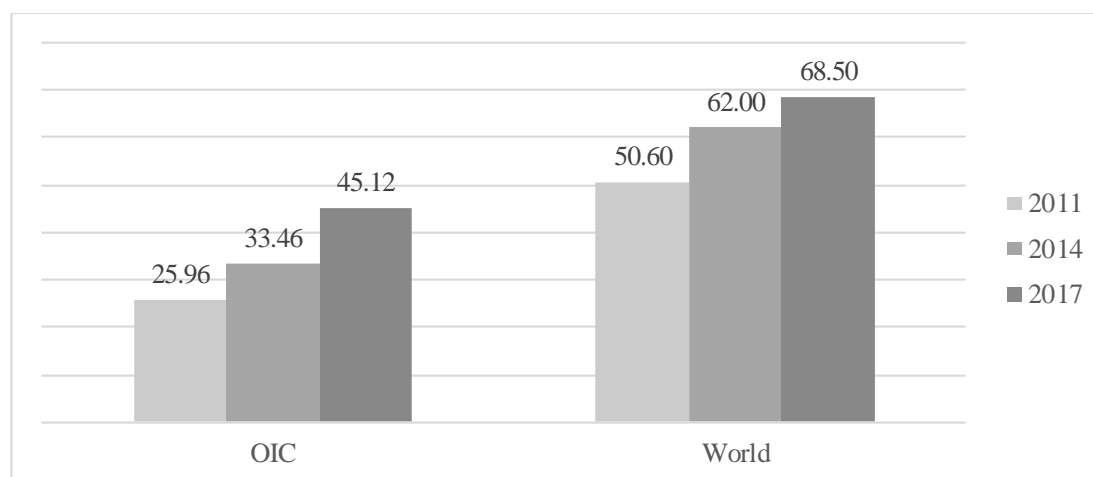

Figure 1. Account (% age 15+) in OIC member countries and world
 Source: Authors' calculation from World Bank's Global Financial Inclusion (Global Findex)⁶⁶ in 2011, 2014 and 2017

Despite abundance of studies around the world reveal that Muslim countries are less included in the formal financial services than non-Muslims (Beck & Brown, 2010; Demirguc-Kunt & Klapper, 2012; Demirguc-Kunt, Klapper, & Randall, 2014; Karlan, Osman, & Shammout, 2017; Kempson, Whyley, Caskey, & Collard, 2000), however, it is still unclear how the researches stated that Muslim countries have low financial inclusion levels whereas they observed financial inclusion level simply by measuring the single indicators i.e. proportion of adults having an account at financial institutions, saved at a financial institutions or borrowed at a financial institutions. Thus, such a measure ignores other important aspects that together form a financial inclusion which are degree of usage and the quality of financial services. As financial inclusion itself is multidimensional, this study attempts to measure financial inclusion levels across 32 OIC countries in 2014 and 2017 using the demand and supply-side multidimensional measurement called index of financial inclusion (IFI) and rank the countries based on the measurement score. Next, the authors analyze the changes of financial inclusion level across the countries in relevant period. The current study is important as to the best of the authors' knowledge, literature lacks a comprehensive measurement on financial inclusion that can bring together both demand and supply-side information in OIC countries using sound weighting methodology.

The principal focus of the financial inclusion is on the financial services offered by the financial institutions (bank, credit union, microfinance institution, cooperative and the post office) that met the varied needs of the societies including accounts, facilities, payments, savings and borrowings. More importantly, this study focus on the financial inclusion towards individual level.

This study is organized as follows: Section 2 reviews the literature on financial inclusion and its measurers; Section 3 presents the data used for measuring financial inclusion level; Section 4 presents the measurement results and details out the discussion; and Section 5 concludes the study.

2.0 LITERATURE REVIEW

When analyzing the existing literature of financial inclusion, there are two popular topics that have been discussed among researchers during the last two decades. One is how to measure financial inclusion level and second is to identify factors significantly associated with it. In measuring financial inclusion level, literature reveals that there is no universal methodology exists for measuring financial inclusion (Raichoudhury, 2020). However, among the pioneer researcher, Sarma (2008) provides insight that a good measurement of financial inclusion should satisfy these criteria – representing all relevant multidimensional yet do not overlap among indicators, being easy to measure and allowing the comparison across countries. Thus, this current study aims to fulfill these criteria.

2.1 Construction of index

In constructing the multidimensional index, the selection of the weight is important for the appropriate measurement of the financial inclusion index because index is sensitive to subjective weighting. Thus, small

⁶⁶ The Global Findex database is the world's most comprehensive data set on how adults save, borrow, make payments and manage risk. Launched with funding from the Bill & Melinda Gates Foundation, the database has been published every three years since 2011. The data are collected in partnership with Gallup, Inc., through nationally representative surveys of more than 150,000 adults in over 140 economies.

changes in weighting resulted dramatically change the value of the index (Lockwood, 2004). Based on the analyzing literature, previous researchers have employed three main approaches which are non-parametric, parametric and coefficient of variation method. The choice of weight in non-parametric method is through instinct or experiential watching of the researcher (Chakravarty & Pal, 2013; Sarma, 2008). However, according to Tuesta and Cámara (2014) this non-parametric method may lead to potential bias. While in parametric method, weight is estimated endogenously through some model assumptions. The latter group, (Amidžić, Massara, & Mialou, 2014) then derive weights through the use of factor analysis, whereas Tuesta and Cámara (2014) employ a principal component analysis. Nonetheless, it should be noted that component analysis and factor analysis methods are not robust if the dataset contains the outlying observation since outliers adversely affect the computation of the factor analysis and principal component analysis. Thus, the authors employ coefficient of variation method to measure weight dimension as this method is unitless. It allows for comparison between distributions of values whose scales of measurement are not comparable (Abdi, 2010).

2.2 Dimensions of financial inclusion

As financial inclusion itself is multidimensional concept hence it cannot be measured by individual indicator. To measure the financial inclusion level, various dimensions need to be considered. Among the first attempts, Sarma (2008) introduces a comprehensive index to measure financial inclusion level of 55 countries in 2004 based on three dimensions - availability, accessibility and usage of financial services. The study finds that seven countries have high financial inclusion level with IFI values of 0.5 and more, while nine countries have medium financial inclusion level including Malaysia and Lebanon with IFI values between 0.3 and 0.5. Most of the countries with high and medium financial inclusion level are Organization for Economic Cooperation and Development (OECD) countries. The remaining 39 countries have low IFI values. Most of the recent studies, (Das & Nayak, 2020; Datta & Singh, 2019; Kim, Yu, & Hassan, 2020) follow the pioneer research and employ the dimension of availability, accessibility and usage of financial services in measuring IFI values.

Using three major dimensions, Das and Nayak (2020) measure financial inclusion level in Odisha state across 30 districts on 31 March 2019 and find that Khurda, Ganjam and Cuttack, which are generally high population, have the highest IFI values. In measuring financial inclusion level of 152 countries including 48 OIC countries for 2014, Kim et al. (2020) reveal that most of OIC countries have low financial inclusion level compared to non-OIC countries due to the religious reasons. Datta and Singh (2019) measure the financial inclusion level across 102 developed and developing countries for the period of 2014 and 2017. The authors find that high income group countries like Canada, Luxembourg, Australia, France and Japan have highest IFI values. Different with Das and Nayak (2020); Datta and Singh (2019); Kim et al. (2020), Nizam, Karim, Abdul-Rahman, and Sarmidi (2020) introduce a new dimension of financial inclusion namely digital financial technology. Thus, the authors employ four dimensions – availability, accessibility, usage and digital financial technology to measure the level of financial inclusion in 63 developed and developing countries for 2014 and 2017. The authors reveal that developed countries like Korea has high financial inclusion level while developing countries like Algeria has low financial inclusion level.

In other studies, Bozkurt and Karakus (2020); Bozkurt, Karakus, and Yildiz (2018); Li, Zhong, and Xie (2020); Ngo (2019); Wang and Guan (2016) employ two dimensions of financial inclusion namely; access and usage of financial services in measuring financial inclusion level. In addition to access and usage dimension, the quality of financial services is also a relevant issue as the lack of use does not necessarily mean lack of access. Based on the access and usage dimension, Bozkurt and Karakus (2020); Li et al. (2020) measure the provinces' financial inclusion level. Li et al. (2020) measure the financial inclusion level in 30 provinces of China from 2010 to 2016 while Bozkurt and Karakus (2020) measure the financial inclusion level in 81 provinces of Turkey from 2011 to 2016. Both researches reveal that the better economic development, the higher the level of financial inclusion. Ngo (2019) measure the financial inclusion level across 36 Asian economies from 2008 to 2016. The author finds that Japan has the greatest IFI value and Afghanistan has the lowest IFI value in Asian countries. Using the dimension of access and usage of financial services, Bozkurt et al. (2018) measure the IFI values 120 countries in 2011 and 2014 while (Wang & Guan, 2016) measure the IFI values across 127 countries in 2011. Both researches reveal that most of the highest level of financial inclusion are from European countries that have relatively high per capita income like United Kingdom.

This discussion shows that the previous studies employ various dimensions in measuring financial inclusion level (Appendix). However, indicators employ in availability and accessibility dimension reveal similarity to cause multicollinearity that can lead to biased results in statistical analysis. As indicated by Pearce and Ortega (2012), a comprehensive dimension to measure financial inclusion are access, usage and quality of financial services. However, quality dimension is difficult to measure empirically. Access dimension measures the depth of outreach

of financial services which are developed from account and facilities while usage dimension measures how clients use financial services, developed from payments, savings and borrowings. Thus, similar to Bozkurt and Karakus (2020); Bozkurt et al. (2018); Li et al. (2020); Ngo (2019); Wang and Guan (2016), this current study measures the financial inclusion level using two dimensions which are access and usage of financial services in order to overcome biased results due to the similar dimensions employed.

2.3 Indicators of financial inclusion

Based on the Appendix, varieties indicators are considered by the previous researchers as proxy of financial inclusion. However, the comprehensive indicators must contain all aspects of financial services like accounts, facilities, payments, savings and borrowings to represent broader view of financial inclusion. In measuring financial inclusion level across 152 countries including 48 OIC countries for 2014, Kim et al. (2020) consider wide indicators of financial inclusion like account (% age 15+), mobile phone used to pay bills (% age 15+), ATMs per 100,000 adults, bank branches per 100,000 adults, credit card (% age 15+), debit card (% age 15+), depositing/withdrawing at least once in a typical month (% age 15+) and domestic credit to private sector (% of GDP). Furthermore, it covers more OIC countries which is 48 countries compared to this study, 32 OIC countries. Unfortunately, this research is not as comprehensive as ours because the researchers simply provide demand-side information. Different with this current study, the authors employ a combination approaches of demand-side dataset from Global Findex and supply-side dataset from International Monetary Funds' Financial Access Survey (FAS)⁶⁷. Thus, these databases fill an important gap in the financial inclusion data landscape.

Given this backdrop, the current study fills the gaps in the existing literature in two ways. First, it attempts to measure the level of financial inclusion in OIC countries using coefficient of variation method, which is statistically sound for index construction as the dataset are in different source and measurement. It has the advantage of not employing any exogenous, subjective information. Second, this study builds a comprehensive index that includes both demand and supply-side information.

3.0 DATA AND METHODOLOGY

3.1 Data description

This analysis is completely based on the secondary data. The dataset is compiled from Global Findex and FAS for the year 2014 and 2017, the latest data for Global Findex dataset as it is a triennial survey. The selection of OIC countries depends on the availability and reliability of data. Thus, 32 out of 57 OIC countries are chosen for the analysis as illustrated in Table 1, listed according to the income group classification by World Bank.

3.2 Constructing the index of financial inclusion (IFI)

In recent decade, when measuring the financial inclusion level, most of the previous researches construct a multidimensional financial inclusion index as it contains numerous information on a single aggregate measure. The multidimensional index helps to boost the comparability of the analysis and able to analyzes the trend of countries' financial inclusion levels comprehensively.

As indicated by the previous researches (Appendix), the key factors to measure financial inclusion are account, facilities, payments, savings and borrowings. Hence, to compute the IFI, the authors categorize data into two dimensions, such as access and usage of financial services, according to Pearce and Ortega (2012). The access of financial services dimension includes four important indicators: credit card ownership (% age 15+), financial institution account (% age 15+), number of commercial bank branches per 100,000 adults and number of ATMs per 100,000 adults. For the usage of financial services dimension, five indicators are included: made digital payments in the past year (% age 15+), saved at a financial institution (% age 15+), outstanding deposits with commercial banks (% of GDP), borrowed from a financial institution (% age 15+) and outstanding loans from commercial banks (% of GDP). Table 2 explain briefly the meaning and the source of each selected indicator.

⁶⁷ The Financial Access Survey (FAS) launched in 2009, is a supply-side dataset on access to and use of financial services aimed at supporting policymakers to measure and monitor financial inclusion and benchmark progress against peers. The FAS is based on administrative data collected by central banks and other financial regulators. The dataset covers 189 countries spanning more than 10 years and contains 121 time-series on financial access and use.

Table 1. Sample of OIC countries

Income group	Country
High income	Kuwait
	Saudi Arabia
	United Arab Emirates
Upper middle income	Albania
	Indonesia
	Iran
	Iraq
	Jordan
	Kazakhstan
	Lebanon
	Malaysia
	Turkey
	Lower middle income
Bangladesh	
Benin	
Cameroon	
Cote d'Ivoire	
Egypt	
Kyrgyz	
Mauritania	
Nigeria	
Pakistan	
Senegal	
Tunisia	
Uzbekistan	
Low income	
	Burkina Faso
	Chad
	Guinea
	Mali
	Niger
	Uganda

Source: World Bank (2020)⁶⁸

In order to measure financial inclusion levels in OIC countries, the authors employ computing algorithm of IFI which is proposed by Wang and Guan (2016) in two main steps. The first step is to generate the dimension indexes ('access' and 'usage' indexes) for each country and the second step is to compute the IFI scores by combining the dimension indexes. The formula for computing algorithm of IFI is given in Eq. 1, 2, 3 and 4.

In Eq. 1, "x" is the transformed value of indicator j for each country k. To transform the indicator values, minimum and maximum values are specified into values on a scale of 0 to 1 using Eq. 2. Next, "w" is the weight of each indicator j. The weight of an indicator j within dimension "I" is calculated as the ratio of variation coefficient of the transformed value in the indicator j to the total of the variation coefficients of all indicators within dimension "I", as stated in Eq. 3. In this study, the coefficient of variation method is used to determine the index weight as coefficient of variation is unitless, thus allows comparison between indicator values whose scales of measurement are not comparable. Table 3 present the summary statistics and weights. Following computed the dimension indexes by Eq. 1; IFI of each country is generated by Eq. 4 as the weighted mean of normalized access and usage indexes. In the Eq. 4, "w" is the weight of each dimension "I" and was calculated as ratio of the sum variation coefficients of all indicators in related dimension to the sum variation coefficients of all indicator within both dimensions. As this study focuses on the changes in IFI scores, thus the changes of IFI score within relevant period are calculated using Eq. 5.

$$\text{Index of Dimension I for Country k} = 1 - \frac{\sqrt{w^2_{i1}(1-x_{ki1})^2 + w^2_{i2}(1-x_{ki2})^2 + \dots + w^2_{in}(1-x_{kin})^2}}{\sqrt{w^2_{i1} + w^2_{i2} + \dots + w^2_{in}}} \quad (1)$$

$$\text{Transformed Value of Indicator j for Country k} = \frac{\text{Actual Value of Country kj} - \text{Minimum Value j}}{\text{Maximum Value j} - \text{Minimum Value j}} \quad (2)$$

$$\text{Weight of j Indicator in Dimension I} = \frac{\text{Coefficient of Variation Ij}}{\sum_j \text{Coefficient of Variation Ij}} \quad (3)$$

$$\text{IFI for Country k} = 1 - \frac{\sqrt{w^2_{\text{Access Index}}(1 - \text{Access Index}_k) + w^2_{\text{Usage Index}}(1 - \text{Usage Index}_k)^2}}{\sqrt{w^2_{i1} + w^2_{i2} + \dots + w^2_{in}}} \quad (4)$$

$$\Delta \text{IFI} = \ln \left(\frac{\text{IFI}_{2017}}{\text{IFI}_{2014}} \right) \quad (5)$$

⁶⁸ <https://data.worldbank.org/country/>

Table 2. Indicators of financial inclusion

Dimension	Topic	Indicator	Source
Access of financial services	Accounts	1. Credit card ownership (% age 15+) “The percentage of respondents who report having a credit card”	Global Findex
		2. Financial institution account (% age 15+) “The percentage of respondents who report having an account (by themselves or together with someone else) at a bank or another type of financial institution”	Global Findex
	Facilities	3. Number of commercial bank branches per 100,000 adults “The number of commercial banks and their branches for every 100,000 adults in the reporting jurisdiction”	FAS
		4. Number of ATMs per 100,000 adults “The total number of ATMs of all financial institutions for every 100,000 adults in the reporting jurisdiction”	FAS
Usage of financial services	Payments	5. Made digital payments in the past year (% age 15+) “The percentage of respondents who report using mobile money, a debit or credit card, or a mobile phone to make a payment from an account, or report using the internet to pay bills or to buy something online, in the past 12 months. It also includes respondents who report paying bills or sending remittances directly from a financial institution or through a mobile money account in the past 12 months”	Global Findex
	Savings	6. Saved at a financial institution (% age 15+) “The percentage of respondents who report saving or setting aside any money at a bank or another type of financial institution in the past 12 months”	Global Findex
		7. Outstanding deposits with commercial banks (% of GDP) “The total amount (in millions of national currency) of all types of outstanding deposits (transferable and non-transferable) of resident non-financial corporations (public and private) and individuals from the household sector with commercial banks as a percentage of GDP”	FAS
	Borrowings	8. Borrowed from a financial institution (% age 15 +) “The percentage of respondents who report borrowing any money from a bank or another type of financial institution in the past 12 months”	Global Findex
		9. Outstanding loans from commercial banks (% of GDP) “The total amount (in millions of national currency) of all types of outstanding loans of resident non-financial corporations (public and private) and individuals from the household sector, with commercial banks, as a percentage of GDP”	FAS

Source: World Bank (2020)⁶⁹ & International Monetary Fund (2020)⁷⁰

4.0 RESULTS AND DISCUSSION

4.1 IFI score

Table 4 exhibits the IFI scores for 32 OIC countries by coefficient of variation method for the years 2014 and 2017. Based on the measurement results in Table 4, the mean of IFI values belonging to 32 OIC countries is 0.2074 in 2014. This average provides evidence that the level of financial inclusion in OIC countries is still in a terrible phrase. Among 32 OIC countries, the five highest ranking of IFI are dominated by United Arab Emirates, Malaysia, Kuwait, Lebanon and Iran. From these countries, four out of five countries are in Middle East & North Africa (MENA) region while Malaysia is in East Asia & Pacific region. All these highest scores of IFI are from high income and upper middle income countries. On the other hand, the five lowest ranking of IFI score are Niger, Guinea, Chad, Afghanistan and Cameroon. Most of the countries are in Sub Saharan Africa region. As expected, these countries are from lower middle income and low income countries.

While for 2017, the average of IFI score is 0.2103. It can be seen that the mean of IFI values belonging to 32 OIC countries in 2017 increases compared to 2014. United Arab Emirates, Lebanon, Kuwait, Malaysia and Turkey are the top five highest ranking of IFI score in 2017. Most of them are in MENA region except Malaysia and Turkey, which are in East & Asia Pacific and Europe & Central Asia respectively. Accordance with IFI score in 2014, the highest IFI score in 2017 are also countries from high income and upper middle income.

Same goes to the five lowest ranking IFI score. Three out of five countries are in Sub Saharan Africa (Guinea, Chad and Niger) while the remaining are in South Asia (Afghanistan) and MENA region (Iraq). These five lowest IFI score countries consist of lower middle income and low income countries. However, one of them is from upper middle income country which, is Iraq. Even though Iraq is upper middle income economies, the level of financial inclusion is still low because of the geopolitical turmoil.

⁶⁹ <https://databank.worldbank.org/source/global-financial-inclusion>

⁷⁰ <https://data.imf.org/?sk=E5DCAB7E-A5CA-4892-A6EA-598B5463A34C>

As expected, based on the financial inclusion results, high income and upper medium countries generally have higher IFI scores compared to lower middle and low income countries. However, it should be noted that the higher IFI score does not necessarily mean the country are also higher in access and usage dimension. Some people may have access to financial services, but choose not to use certain financial services (Demirguc-Kunt et al., 2014). In contrast, some countries may lack of financial facilities like bank branches, but the societies choose to use mobile banking for the transactions. The authors reveal that country with the highest access index in 2014 is Turkey with score of 0.6915 while Malaysia is the highest usage index with the score of 0.5689. In 2017, with the score of 0.7107, Turkey still dominates in the access index as credit card ownership and number of ATM indicator in Turkey is very high compared to other OIC countries. However, for the usage index, Lebanon replaces Malaysia in 2017 with the score of 0.5430.

4.2 The changes of IFI score

As illustrated in Table 4, the country with the highest change from the year 2014 to 2017 is Cameroon, with 73.22% increase. Based on the raw data, made digital payments in the past year (% age 15+) indicator exhibits drastically increased from 4.82% to 24.50% compared to other indicators. In Cameroon, people are excluded from the financial system due to high cost of financial services, the distance of financial institutions, the requirement to open bank account, poor customer service, do not have guarantees and bad credit history (Mbua, 2019). Thus, mobile technology becomes the key element in increasing Cameroon's financial inclusion level. This technology has enabled thousands of people to access financial services such as payments, transfers of fund and account opening. A report published by the Cameroonian ministry of posts and telecoms shows significant growth in the country's mobile penetration rate from 12% in 2005 to almost 83% in 2016. Hence, mobile technology offers the chance to boost economic growth and expand financial inclusion in Cameroon (Mbua, 2019). Besides, increasing in financial institution account (% age 15) from 11.35% to 26.87% is due to the initiative from Cameroon authorities. The International Finance Corporation (IFC), a member of the World Bank Group, has announced an advisory services agreement with Microfinance Institute Advans Cameroon to expand the reach of services available to underprivileged urban and rural populations (Iruobe, 2015).

Guinea is also experiences a positive change of IFI with 63.37% increase. Same like Cameroon, made digital payments in the past year (% age 15+) indicator exhibits a huge increased from 4.82% to 24.50%. According to International Monetary Fund (2020), the usage of mobile money (transferred via mobile telephone) has grown rapidly in recent years and promotes financial inclusion in Guinea. The increasing in digital payments is due to the regulatory framework that proposed in 2015 entitled 'Financial Inclusion and Mobile Banking in Guinea.' Increasing in 56.84% from 2014 to 2017, this positive changes of Mali is because of the effectiveness of microfinance programme. Data on saved at a financial institution (% age 15) and borrowed from a financial institution (% age 15) are increasing from 2.89% to 6.07% and from 2.74% to 6.25% respectively (in 2014 and 2017) due to increasing in microfinance products. International Fund for Agricultural Development take initiative in funding rural microfinance programme. This initiative is working to change the unbanked society through improving the access of 500,000 low-income rural Malians to financial services. This effective programme make 105,000 rural women (4,000 groups) are now banked and solvent clients of the microfinance institutions. These groups have been trained on financial literacy, business plan preparation, management support and networking with financial institutions (Food and Agriculture Organization of the United Nations, 2018).

On the other hand, the country with the lowest change is Nigeria with 42.49% decrease. There are numerous factors why Nigeria's financial inclusion lagging compared to other African countries. One of the factor is financial exclusion in Nigeria is strongly related to poverty. As indicated by InterMedia (2016), the wealthiest 20% of households are at 8 times more likely to have an account than the poorest households. Second, high levels of exclusion in the north Nigeria is because of the Islamic prohibition of interest (Okere & Shepherd, 2015). Hence, greater inclusion therefore requires financial services based on Sharia-compliant products. Third, many Nigerians lack of the skills that facilitate financial inclusion such as financial literacy (Okere & Shepherd, 2015).

Table 3. Summary of indicators composing the index of financial inclusion (data from 32 OIC countries)

	2014					2017						
	Max	Min	SD	CV	Wij	W1	Max	Min	SD	CV	Wij	W1
Dimension 'Access'						0.45587						0.46368
Credit card ownership (% age 15+)	37.4240	0.12597	0.25546	1.43744	0.32314		45.4422	0.19996	0.24564	1.36600	0.32456	
Financial institution account (% age 15+)	92.1752	3.49004	0.28598	0.86086	0.19352		93.3563	8.75350	0.28153	0.77877	0.18503	
Number of commercial bank branches per 100,000 adults	43.0848	0.97307	0.23086	1.03892	0.23355		38.5238	1.00016	0.23567	0.99485	0.23637	
Number of ATMs per 100,000 adults	79.6042	0.74972	0.31699	1.11119	0.24979		81.9526	1.21324	0.33314	1.06917	0.25403	
Dimension 'Usage'						0.54413						0.53632
Made digital payments in the past year (% age 15+)	71.6140	2.60882	0.28873	1.09143	0.20556		79.3933	3.75869	0.26491	0.74804	0.15366	
Saved at a financial institution (% age 15+)	33.7706	1.83656	0.28843	0.98039	0.18464		37.7697	1.62485	0.24992	0.83000	0.17050	
Outstanding deposits with commercial banks (% of GDP)	244.018	10.6546	0.23933	1.27838	0.24076		294.801	11.0520	0.22381	1.31821	0.27079	
Borrowed from a financial institution (% age 15+)	31.5644	1.27720	0.23678	0.92263	0.17376		23.8538	2.09630	0.27806	0.83944	0.17244	
Outstanding loans from commercial banks (% of GDP)	193.838	3.67480	0.20487	1.03685	0.19528		265.168	3.03896	0.19153	1.13238	0.23261	

Source:

Authors' calculation from secondary data

Notes:

1. 'Max' and 'Min' values are raw data for each indicator.
2. 'SD' is standard deviation of transformed values of indicator j.
3. 'CV' is coefficient of variation, (SD/Mean of transformed values of indicator j).
4. 'Wij' is weight of indicator j in dimension i.
5. 'W1' is weight of dimension.

Table 4. IFI score of OIC countries (2014 and 2017)

Income group	Country	Access ₂₀₁₄	Usage ₂₀₁₄	IFI ₂₀₁₄	Rank ₂₀₁₄	Access ₂₀₁₇	Usage ₂₀₁₇	IFI ₂₀₁₇	Rank ₂₀₁₇	ΔIFI	
High income	Kuwait	0.6051	0.4141	0.4843	3	0.5453	0.4007	0.4578	3	-5.62%	
	Saudi Arabia	0.4074	0.3300	0.3608	7	0.4370	0.2789	0.3419	7	-5.38%	
	United Arab Emirates	0.6477	0.5406	0.5815	1	0.6471	0.5047	0.5599	1	-3.77%	
Upper middle income	Albania	0.3093	0.2121	0.2506	11	0.3104	0.1878	0.2378	13	-5.24%	
	Indonesia	0.2637	0.2585	0.2606	10	0.2908	0.2391	0.2608	12	0.05%	
	Iran	0.5147	0.3977	0.4430	5	0.4738	0.3553	0.4031	6	-9.43%	
	Iraq	0.0598	0.0415	0.0490	27	0.0530	0.0385	0.0447	29	-9.17%	
	Jordan	0.1948	0.2692	0.2377	13	0.2162	0.3338	0.2811	10	16.79%	
	Kazakhstan	0.3584	0.2040	0.2638	9	0.4106	0.2106	0.2893	9	9.24%	
	Lebanon	0.3943	0.5077	0.4581	4	0.4157	0.5430	0.4847	2	5.66%	
	Malaysia	0.5087	0.5689	0.5431	2	0.4673	0.4394	0.4512	4	-18.54%	
Lower middle income	Turkey	0.6915	0.3197	0.4422	6	0.7107	0.3066	0.4424	5	0.05%	
	Algeria	0.1699	0.1698	0.1698	15	0.1222	0.1502	0.1381	19	-20.68%	
	Bangladesh	0.0913	0.1670	0.1350	19	0.1075	0.1993	0.1588	15	16.26%	
	Benin	0.0574	0.1214	0.0945	23	0.1111	0.1413	0.1282	20	30.56%	
	Cameroon	0.0303	0.0549	0.0447	28	0.0667	0.1129	0.0929	25	73.22%	
	Cote d'Ivoire	0.0659	0.1469	0.1126	21	0.0612	0.0932	0.0793	27	-35.02%	
	Egypt	0.0873	0.1396	0.1176	20	0.1339	0.1858	0.1632	14	32.74%	
	Kyrgyz	0.1618	0.1203	0.1372	18	0.2054	0.1106	0.1498	16	8.83%	
	Mauritania	0.1302	0.4150	0.2837	8	0.1139	0.4880	0.3029	8	6.57%	
	Nigeria	0.1552	0.2064	0.1849	14	0.1292	0.1147	0.1209	23	-42.49%	
	Pakistan	0.0672	0.0557	0.0604	26	0.0969	0.0724	0.0828	26	31.50%	
	Senegal	0.0559	0.1066	0.0853	24	0.0820	0.1526	0.1217	22	35.48%	
	Tunisia	0.2690	0.2368	0.2499	12	0.2962	0.2610	0.2759	11	9.87%	
	Uzbekistan	0.2118	0.0991	0.1438	17	0.2365	0.0811	0.1441	17	0.22%	
	Low income	Afghanistan	0.0306	0.0334	0.0323	29	0.0225	0.0261	0.0245	32	-27.37%
		Burkina Faso	0.0618	0.1191	0.0950	22	0.0821	0.1858	0.1399	18	38.72%
Chad		0.0192	0.0373	0.0298	30	0.0255	0.0349	0.0309	30	3.45%	
Guinea		0.0355	0.0246	0.0291	31	0.0459	0.0616	0.0548	28	63.37%	
Mali		0.0554	0.0730	0.0657	25	0.1067	0.1230	0.1160	24	56.84%	
Niger		0.0183	0.0263	0.0230	32	0.0231	0.0279	0.0258	31	11.64%	
Uganda		0.0743	0.2394	0.1673	16	0.0716	0.1661	0.1244	21	-29.62%	
<i>Average</i>				<i>0.2074</i>				<i>0.2103</i>			

Source:

Authors' calculation from secondary data.

Notes:

1. An IFI value of 1 signifies the highest score of financial inclusion level and value of 0 signifies the lowest score of financial inclusion level.
2. Average is the mean of IFI values belonging to 32 OIC countries.

In Cote d'Ivoire, the IFI score of is decreased to 35.02%. It seems that most Ivorians prefer to save their money under the mattress. Besides, most of the rich Ivorians save in accounts abroad (World Bank, 2016). Ivorians are turning their backs on local banks because of the historic and practical factors. Their reluctance can be explained by the political crisis, which weakened the trust between banks and their clients. Besides, it can also be referred to the historic failures of some public banks that are likely to be closed, restructured, or privatized (World Bank, 2016).

5.0 CONCLUSION

Financial inclusion is a multidimensional concept thus it cannot be measured simply using single indicator. To comprehensively measure the level of financial inclusion, a multidimensional measurement called index of financial inclusion need to be considered. However, existing financial inclusion index are questionable since they employ arbitrary weights that may lead to bias. While some of the researches employ system like principle component analysis and factor analysis methods that are not robust if the dataset contains the outlying observation. This current study uses coefficient of variation method, which allows comparison between values in different measurement to determine the weight of each index. This methodology is statistically sound for index construction as our dataset are in different measurement.

Therefore, the authors employ the coefficient of variation method in measuring the financial inclusion level through a multidimensional index, for 32 OIC countries in 2014 and 2017 using a comprehensive dataset from demand and supply-side information. The index is comparable across countries and over time. The result provides evidence that high income and upper middle income countries have higher level of financial inclusion as compared to lower middle income and low income countries. It is interesting to note that financial inclusion level in OIC countries varies greatly between regions. The IFI in MENA is significantly higher compared to other regions. Finally, the panel data is used to analyze the changes of OIC financial inclusion level between 2014 and 2017. There are a huge positive changes in Cameroon, Guinea and Mali due to increasing in financial technology. While Nigeria and Cote d'Ivoire experience a huge negative changes of financial inclusion level. In Nigeria, this happened because they cannot afford to use financial services due to the high cost, while Cote d'Ivoire face lack of trust issue towards financial institutions.

In terms of policy implication, this study suggests policymakers in each OIC countries to prioritize their efforts via providing conducive environment for the increasing economic growth and financial sector development to raise the level of financial inclusion especially in lower middle and low income countries. With robust strategies, financial inclusion will be able to economically and socially empower and uplift the quality of life of the underprivileged Muslims in OIC countries, thus meet the target of 'Leave No One Behind' of Agenda 2030.

This study proposes several recommendations for future researchers of financial inclusion in OIC countries. First, other relevant indicators based on access and usage of financial services dimensions could be included in the computation of the IFI to boost the efficiency of its measurement. Second, due to limitation of data in this study, future researchers shall access to large panel datasets for capturing the wider perspectives on the financial inclusion level in OIC countries.

ACKNOWLEDGEMENTS

This study is part of the project entitled "The Role of Islamic Microfinance in Promoting Financial Inclusion" funded by Geran Inisaitif Penyelidikan 2019 (EP-2019-016).

REFERENCES

- Abdi, H. e. (2010). Coefficient of variation. In N. Salkind (Ed.), *Encyclopedia of Research Design*. Thousand Oaks, CA: Sage.
- Amidžić, G., Massara, A., & Mialou, A. (2014). *Assessing countries' financial inclusion standing: a new composite index*. Retrieved from Beck, T. H. L., & Brown, M. (2010). Which households use banks? Evidence from the transition economies. *Tilburg University, Center for Economic Research, Discussion Paper*.
- Bozkurt, I., & Karakus, R. (2020). Provincial financial inclusion in Turkey: measurement and its spatial determinants. *Ege Academic Review*, 20, 101-124. doi:10.21121/eab.729532
- Bozkurt, I., Karakus, R., & Yildiz, M. (2018). Spatial determinants of financial inclusion over time. *Journal of International Development*, 30.
- Chakravarty, S., & Pal, R. (2013). Financial inclusion in India: an axiomatic approach. *Journal of Policy Modeling*, 35, 813–837.
- Crabtree, S. (2010). Religiosity highest in world's poorest nations. Retrieved from <https://news.gallup.com/poll/142727/religiosity-highest-world-poorest-nations.aspx>
- Das, G. S., & Nayak, B. (2020). An empirical study: the impact of financial inclusion in the state of Odisha. *Test Engineering and Management*, 83, 14474-14481.
- Datta, S., & Singh, D. (2019). Variation and determinants of financial inclusion and association with human development: a cross country analysis. *IIMB Management Review*, 31. doi:10.1016/j.iimb.2019.07.013
- Demirguc-Kunt, A., & Klapper, L. (2012). Measuring financial inclusion: the Global Findex database. doi:10.1596/1813-9450-6025
- Demirguc-Kunt, A., Klapper, L., & Randall, D. (2014). Islamic finance and financial inclusion: measuring use of and demand for formal financial services among Muslim adults. *Review of Middle East Economics and Finance*, 10. doi:10.1515/rmef-2013-0062
- Demirguc-Kunt, A., Klapper, L., Singer, D., Ansar, S., & Hess, J. (2018). *The Global Findex database 2017: measuring financial inclusion and the fintech revolution*.
- Food and Agriculture Organization of the United Nations. (2018). Toward greater financial inclusion in Mali. Retrieved from <http://www.fao.org/support-to-investment/our-work/success-story-detail/en/c/1158437/#:~:text=An%20IFAD%20funded%20rural%20micro%20finance,support%20its%20implementation%20in%2017>.
- InterMedia. (2016). *Financial Inclusion Insights from Nigeria*. Retrieved from
- International Monetary Fund. (2020). *Guinea: Financial Sector Stability Review*. Retrieved from Washington:
- Iruobe, E. (2015). World Bank boosts financial inclusion in Cameroon. Retrieved from <http://venturesafrica.com/blog/2020/08/31/kenya-airways-future-bleak-posting-132mn-half-year-loss/>
- Karlan, D., Osman, A., & Shammout, N. (2017). To borrow or not to borrow: religious norms and the elasticity of demand for credit.
- Kempson, E., Whyley, C., Caskey, J., & Collard, S. (2000). *In or out? Financial exclusion: a literature and research review*. London: Financial Services Authority.
- Kim, D.-W., Yu, J.-S., & Hassan, M. K. (2020). The influence of religion and social inequality on financial inclusion. *The Singapore Economic Review*, 65. doi:10.1142/S0217590817460031
- Li, Y., Zhong, Q., & Xie, L. (2020). Has inclusive finance narrowed the income gap between urban and rural areas? an empirical analysis based on coastal and noncoastal regions' panel data. *Journal of Coastal Research*, 31(106), 305-308.
- Lockwood, B. (2004). How robust is the Kearney/foreign policy globalisation index? *The World Economy*, 27, 507-523. doi:10.1111/j.0378-5920.2004.00611.x
- Mbua, P. (2019). Fintech — the gateway to financial inclusion in cameroon. Retrieved from <https://medium.com/datadriveninvestor/fintech-the-gateway-to-financial-inclusion-in-cameroon-45eb51d3cd3>
- Ngo, A. (2019). Index of financial inclusion and the determinants: an investigation in Asia. *Asian Economic and Financial Review*, 9, 1368-1382. doi:10.18488/journal.aefr.2019.912.1368.1382
- Nizam, R., Karim, Z., Abdul-Rahman, A., & Sarmidi, T. (2020). Financial inclusiveness and economic growth: new evidence using a threshold regression analysis. *Economic Research-Ekonomika Istraživanja*, 33, 1465-1484. doi:10.1080/1331677X.2020.1748508
- Okere, A., & Shepherd, A. (2015). *Financial inclusion in Nigeria*.
- Pearce, D., & Ortega, C. (2012). *Financial inclusion strategies reference framework*. Washington: World Bank.
- Raichoudhury, A. (2020). Major determinants of financial inclusion: state-level evidences from India. *Vision: The Journal of Business Perspective*, 24, 097226292092388. doi:10.1177/0972262920923882
- Sarma, M. (2008). *Index of Financial Inclusion*. Retrieved from
- Tuesta, D., & Cámara, N. (2014). *Measuring financial inclusion: a multidimensional index*.
- Wang, X., & Guan, J. (2016). Financial inclusion: measurement, spatial effects and influencing factors. *Applied Economics*, 49, 1-12. doi:10.1080/00036846.2016.1226488
- World Bank. (2016). Financial services in Cote d'Ivoire: banks set aside in favor of mobile money. Retrieved from <https://www.worldbank.org/en/country/cotedivoire/publication/financial-services-in-cote-divoire-banks-set-aside-in-favor-of-mobile-money>
- World Bank. (n. d.). Financial inclusion is a key enabler to reducing poverty and boosting prosperity. Retrieved from <https://www.worldbank.org/en/topic/financialinclusion/overview>

APPENDIX

Table 5. Literature review

Author	Aim of the research	Dimension and indicator of financial inclusion	Source of data	Method	Finding
Li et al (2020)	To measure the financial inclusion level in 30 provinces of China from 2010 to 2016.	1. Access of financial services Number of financial institutions per 10,000 km ² Number of employees in financial institutions per 10,000 km ² Number of financial institutions per 10,000 population Number of employees in financial institutions per 10,000 population 2. Usage of financial services Deposit balance/GDP Loan balance/GDP Insurance depth	1. China Statistical Yearbook 2. Financial Data of People's Bank of China 3. Local Insurance Regulatory Bureaus	Coefficient of variation	The financial inclusion level in coastal regions is higher than non-coastal regions. The better economic development, the higher the financial inclusion level.
Bozkurt and Karakus (2020)	To measure financial inclusion level in 81 provinces of Turkey from 2011 to 2016.	1. Access of financial services Number of account at the financial institutions per adults age 15+ The proportion of active customers having internet banking account to adults age 15+ Number of ATMs per 100,000 adults age 15+ Number of commercial bank branches per 100,000 adults age 15+ Number of ATMs per 1,000 km ² Number of commercial bank branches per 1,000 km ² 2. Usage of financial services Outstanding deposits with commercial banks per adults 15+ Outstanding deposits with commercial banks (% of GDP) Outstanding loans from commercial banks per adults 15+ Outstanding loans from commercial banks (% of GDP) The proportion of checks used to make payments to adults age 15+	1. Statistical Reports of The Banks Association of Turkey	Coefficient of variation	Istanbul is the highest level of IFI in Turkey. The provinces with high level of IFI are generally high income provinces.
Das and Dayak (2020)	To measure financial inclusion level in Odisha state across 30 districts on 31 March 2019.	1. Accessibility of financial services Availability of banking services per 100,000 km ² 2. Availability of financial services Number of ATMs per 100,000 km ² 3. Usage of financial services Business correspondents appointed per 100,000 km ²	1. Reserve Bank of India	Non-parametric method: Equal weight	Khurda, Ganjam and Cuttack have the highest IFI level. The districts with high level of IFI are generally high population.
Kim et al (2020)	To measure financial inclusion level across 152 countries including 48 OIC countries for 2014.	1. Accessibility of financial services Account (% age 15+) Mobile phone used to pay bills (% age 15+) 2. Availability of financial services ATMs per 100,000 adults Bank branches per 100,000 adults 3. Usage of financial services Credit card (% age 15+) Debit card (% age 15+) Depositing/withdrawing at least once in a typical month (% age 15+) Domestic credit to private sector (% of GDP)	1. Global Findex 2. World Bank's Global Financial Development	Non parametric method: Separate weight – 1 for availability of financial services, 0.5 for accessibility and usage of financial services.	Most OIC countries are low financial inclusion level compared to non-OIC countries due to religious reasons.
Nizam et al (2020)	To measure financial inclusion level across 63	1. Accessibility of financial services Number of deposit accounts with commercial banks per 1,000 adults	1. Global Findex 2. FAS	Parametric method: Principle	Developed countries like Korea

	developed and developing countries for 2014 and 2017.	<p>2. Availability of financial services Number of ATM per 100,000 adults Number of commercial bank branches per 100,000 adults</p> <p>3. Usage of financial services Outstanding loans from commercial banks (% of GDP) Outstanding deposits with commercial banks (% of GDP)</p> <p>4. Digital financial technology Used the internet to pay bills or to buy something online in the past year (% age 15+) Paid utility bills using a mobile phone (% age 15+) Made or received digital payments in the past year (% age 15+)</p>	component analysis	have high financial inclusion level.	
Datta and Singh (2019)	To measure financial inclusion level across 102 developed and developing countries for 2014 and 2017.	<p>1. Availability of financial services Number of ATMs per 1,000 km² Number of commercial bank branches per 1,000 km² Number of ATMs per 100,000 adults Number of commercial bank branches per 100,000 adults</p> <p>2. Access of financial services Financial institutions account (age 15+) Debit card ownership (age 15+)</p> <p>3. Usage of financial services Borrowed from a financial institution (age 15+) Saved at a financial institution (age 15+) Received domestic remittances in the past year (age 15+)</p>	1. Global Findex 2. FAS	Parametric method: Principle component analysis	High income group countries like Canada, Luxembourg, Australia, France and Japan experienced higher level of financial inclusion.
Ngo (2019)	To measure financial inclusion level across 36 Asian countries from 2008 to 2016.	<p>1. Access of financial services ATMs per 100,000 adults Bank branches per 100,000 adults</p> <p>2. Usage of financial services Domestic credit provided by financial sector (% of GDP) Number of depositors with commercial banks per 1,000 adults Financial system deposits to GDP (%)</p>	1. Global Findex 2. FAS 3. World Bank's World Development Indicators	Parametric method: Principle component analysis	Japan shows the greatest IFI.
Bozkurt et al (2018)	To measure financial inclusion level across 120 countries for 2011 and 2014.	<p>1. Access of financial services Credit card ownership (% age 15+) Financial institution account (% age 15+) Number of ATMs per 100,000 adults Number of commercial bank branches per 100,000 adults</p> <p>2. Usage of financial services Made digital payments in the past year (% age 15+) Saved at a financial institutions (% age 15+) Outstanding deposits with commercial banks (% of GDP) Borrowed from a financial institution (% age 15+) Outstanding loans from commercial banks (% of GDP)</p>	1. Global Findex 2. FAS	Coefficient of variation	Highest IFI in 2014 are Luxembourg, Spain, United Kingdom, Belgium (European countries); Australia, New Zealand (Oceania); United States, Canada (North America); Japan and Korea (Asia). These countries have relatively high per capita income. From 10 lowest IFI score, 7 countries are African countries with low per capita income while the remaining three countries are Asian countries.

Wang and Guan (2017)	To measure financial inclusion level across 127 countries for 2011.	<p>1. Access of financial services</p> <ul style="list-style-type: none"> Debit card ownership (% age 15+) Formal institution account (% age 15+) Number of ATMs per 100,000 adults Number of commercial banks branches per 100,000 adults <p>2. Usage of financial services</p> <ul style="list-style-type: none"> Used checks to make payments in the past year (% age 15+) Made digital payments in the past year (% age 15+) Saved at a financial institution (% age 15+) Outstanding deposits with commercial banks (% of GDP) Borrowed from a financial institution (% age 15+) Outstanding loans from commercial banks (% of GDP) 	1. Global Findex 2. FAS	Coefficient of variation	The highest level of financial inclusion is Australia, Canada, New Zealand, United States, Ireland, France, United Kingdom, Portugal, Korea and Cyprus. Most of them are European countries.
----------------------	---	--	----------------------------	--------------------------	--

THE CONCEPT OF HALALAN TAYYIBAN FROM THE MANUAL PROCEDURE FOR MALAYSIA HALAL CERTIFICATION (THIRD REVISION) 2014 (MPPHM 2014)

Nadiyah Abdul Lateb, Syarifah Md Yusof, Nor Aina Mhd Khotib

Islamic Business School, Universiti Utara Malaysia, Sintok, 06010, Kedah, Malaysia

Abstract

The term halal is very well recognized in Malaysia. However, the term halalan tayyiban is not well versed by most of the Muslim community in this country. The practice of the concept of halalan tayyiban among Muslim food operators is questionable and doubtful. Previous studies have shown that there were a lot of misunderstanding and misconceptions about the halal certification. Some food premises in Malaysia were reluctant to apply for the Halal Certification were because it seems like a hard task for them to comply with the halal certification. Thus, this paper is aim to explore the concept of halalan tayyiban in the food preparation at the food premise by using the documents of Manual Procedure for Malaysia Halal Certification (Third Revision) 2014 which includes the four aspects for the halalan tayyiban concept which are pure, hygiene, safe and quality. The Manual Procedure for Malaysia Halal Certification (Third Revision) 2014 (MPPHM 2014) contains guidelines for Department of Islamic Development Malaysia (JAKIM) and the States Department of religious Affairs (JAIN) and Islamic Religious Affairs Council (MAIS) Inspection Officers, intending to clarify requirements to be complied with, in managing the Malaysia Halal Certification. These guidelines help the appointed regulated bodies in making sure that the halalan tayyiban is well assured.

Key Words: Halalan Tayyiban Concept, Halalan Tayyiban, Food Premise

1.0 INTRODUCTION

The halal industry development has placed Malaysia as the main halal hub destination in the world. This effort is to transform the human lifestyle that followed the Islamic principle as a whole. The majority of Muslim consumers usually take things for granted that the food must be halal if it was prepared or sell by the Muslim. However, should Muslim consumers be aware and concerned about what they eat and how their daily food and drinks are processed and handled?

Hence, the food premise operators need to understand and apply the halalan tayyiban concept in their daily business operations. For food premise operators to be able to follow the halal compliance, a system such as Manual Procedure for Malaysia Halal Certification (Third Revision) 2014 is recommended. Manual Procedure for Malaysia Halal Certification guarantees that the food operators will not be going to have a possibility of making mistakes or omission during their daily business practices because it has provided clear and easy halal guidelines to follow.

2.0 PROBLEM STATEMENT

Although Malaysia is very well known in halal products and being referred by other countries in the world for its Manual Procedure for Malaysia Halal Certification, not all food premises in Malaysia apply and adopt this halal certification for their products and premises. As the application of halal certification is optional, the premise's willingness to apply is very recommended. Instead, there is no way to punish those who do not apply the halal certification as it is based on volunteerism.

There is no doubt regarding halal on the food premise with halal certification or halal logo presented in their premises as they are compulsory to follow strictly the Manual Procedure for Malaysia Halal Certification. Otherwise, their certification could be suspended or terminated in the case of non-compliance with the Manual Procedure for Malaysia Halal Certification. However, it is questionable and doubtful if the food premises are not the holder of Malaysia Halal Certification. This issue raises many concerns as (Zannierah Syed Marzuki, Hall, & Ballantine, 2012) found that most of the restaurant managers viewed that it seems hard tasks for them to comply with the halalan tayyiban concept and its standard. If the food operators are hard to follow Manual Procedure for Malaysia Halal Certification, the halalan tayyiban concept being practice could not be guaranteed.

3.0 LITERATURE REVIEW

3.1 Halalan Taiyyiban

Principle of Halalan Tayyiban derives from two basic terms, that is, halal, which refers to the things or actions that are permitted or lawful by the Syariah law, and Tayyib, which relates to wholesomeness and cleanliness. Accordingly, the principle of Halalan Tayyiban emphasizes that any product that is to be consumed and used must be allowable and permissible, as well as up to the standard of quality, safety and cleanliness as underlined by the Islamic law. Concerning food products, halal indicates that the food consumed must be allowed to be consumed under the Islamic law while tayyib emphasizes that all food must be clean, of quality, nutritious. (Zainol et al., 2019)

Halal is not only mandatory for all Muslims but also a very important and essential concept in Islam. Consumption of halal products such as food, daily supplies is compulsory for every Muslim.

Basically, from the different definitions recognized, halal food is a pure, clean, safe and quality to consume from anything filthy which is thought to be lawful as per Islamic law and also free from any prohibited ingredients. A halalan tayyiban concept that can be understood by all the definitions is according to these four main aspects which are pure, hygiene, safe and quality.

3.1.1 Pure

All Muslims are aware of the importance of halal food, and this has led to the expansion of the world halal food industry. With the Quran calling for food to be not only halal but also Tayyib, or pure, this has led to segments of the halal food sector creating products of the highest quality, as seen in the rise of halal organic food. Consequently, non-Muslim demand for such quality food is also increasing. (Bashir et al., 2019)

The pure aspect of the halalan tayyiban concept mostly related to the source of food must be from the halal source. Foods can broadly classify into four groups to establish their halal status and to formulate guidelines for halal preparation or production. The first group is meat and poultry. Muslims only allowed to consume halal animals. These animals should be healthy and must be slaughtered by a sane adult Muslim while pronouncing the name of God. A sharp knife must be used to cut the throat in a manner that induces thorough removal of blood and quick death of the animal.

The second food group is fish and seafood. all groups of Muslims accept fish with scales. Some group did not eat fish without scales such as catfish. Muslims scholars have differing opinions about certain seafood products which include the acceptability of molluscs (clams, oyster and squids) and crustaceans (crabs, lobster and shrimp). The requirements and restrictions apply not only to fish and seafood but also to flavours as well as ingredients derived from those products.

The third group on food is milk and egg. Milk and eggs from halal animals are halal. Milk predominantly comes from cows and eggs from hens. All other sources must be labelled accordingly.

The fourth food group is plant and vegetable. All foods from plants are halal, except for *khamr* (intoxicants) and poisonous ones. However, animal and vegetable products are sometimes used in the same plant which can cause cross-contamination. food manufacturer, therefore, needs to follow a proper cleaning procedure and separate between halal and non-halal materials. (al-Qaradawi, 2013)

3.1.2 Hygiene

There are a few definitions of food hygiene in current use. According to the World Health Organization (2018), food hygiene is the conditions and measures necessary to ensure the safety of food from production to consumption (farm to fork). During slaughtering or harvesting, processing, storage, distribution, transportation and preparation, food can become contaminated at any point. It can lead to foodborne diseases and the death of the consumer if food operators are lack of adequate food hygiene. While according to Codex Alimentarius Commission (2008) food hygiene is all conditions and measures necessary to ensure the safety and suitability of food at all stages of the food chain.

The most important hygiene practice is in the production areas where the food operators should ensure that a regular cleaning system is implemented to prevent dirt from gathering on windows ledges or around table legs and other inaccessible places. All floors and drains should be washed down daily. During production, any spillage

of food should be cleared straight away, and wastes should not be allowed to accumulate on floors, in drains or on work surfaces. They should be placed in covered bins and emptied at regular intervals, and should be disposed of properly away from the processing site (Azam-Ali, 2003).

All food premise surfaces and equipment must be washed with hot water and detergents before, during and after production. If surfaces, chopping boards or utensils (such as knives) are used for different foods they should be washed between each use. Cloths and sponges used to wipe down surfaces and towels used for hand drying should be washed and sterilized regularly by boiling in water for at least 10 minutes. Equipment and utensils should be stored where they can be kept clean when not in use, and brushes and cloths should be hung up after use, and never left on equipment or foods to dry. Cleaning equipment, chemical and detergents should be stored in a separate cupboard from foods and processing equipment. All the equipment should be kept in good condition and properly repaired, to prevent accidents as well as contamination. Only food-grade plastic, ceramic, stainless steel or enamelled metals are suitable materials for use in contact with foods. Copper, iron, brass or pewter should not be used. Galvanized iron or aluminium is only appropriate to use for some foods and wooden utensils or surfaces are difficult to clean (Azam-Ali, 2003).

The hygiene aspect also includes a good sanitation system at the food premise. Sanitation is a term for the hygienic disposal or recycling of waste materials. In consequence, sanitation is an important public health measure that is essential for the prevention of disease. In the USA, there is a particular focus on the concept of food sanitation, which may be defined as 'the hygienic practices designed to maintain a clean and wholesome environment for food production, preparation and storage' (Marriott & Gravani, 2006). This definition links it to hygiene but more specifically with maintaining a clean working environment for food processing. Even here hygienic requirements extend beyond the practice of cleaning itself to incorporate those elements that make effective cleaning possible and allow control of insects and other pests. In the microbiological sense, sanitation is defined as 'a cleaning and disinfection process that results in a 99-99.9% reduction in the number of vegetative bacteria present' (Lelieveld, Holah, & Gabrić, 2016).

Based on the explanation above, hygiene in food premises consists of the premise areas, environment, tools and equipment. The food premise operators should practice a good hygiene system in their production of foods at their food premises.

3.1.3 Safe

Workers in food premise are one important element in making sure all the practice of foods operations is in line with the halalan tayyiban concept because they are the food handlers that are responsible in protecting the safeness of the foods to consume. According to the Food Hygiene Regulations 2009, Clothing of food handler or the attire for food handlers is that they should wear a clean, suitable and proper clothing and clean, suitable and light coloured overall or light coloured apron, headcover and footwear. This should be followed by all the workers who work in food premise.

Basic amenities are some of the basic facilities provided for the workers in the food premise such as toilet, praying room, changing room and pantry. These basic amenities should be well taken care of to take care of the welfare of all the workers so that it is easier for them to have good performance at their respective workplace (JAKIM, 2015)

According to the Food Hygiene Regulations 2009, medical examination and health condition of food handler is compulsory for all food handlers. Food handler who suffers from, or is a carrier of foodborne diseases is not be allowed to enter food premises and handle food. The food handlers who suffered from the foodborne disease should be reported to the management of the food premises and will be suspended from working in food premises until certified cured of the disease and fit to work. According to the Food Act 1983 and Disease Control 1988, the health of all food operators should be examined and should be given the typhoid immunization vaccine by the health practitioners. Typhoid immunization vaccine is an active immunization against typhoid fever caused by *Salmonella typhi*. The vaccination cards will be issued for those who got the typhoid immunization vaccine and it is valid for three years after they got injected.

3.1.4 Quality

The halalan tayyiban concept can be understood in health practices through healthy choices of food as well. It is related closely to the quality of food that contains good nutrients, hygienic and good quality of food as well as the storage system with a suitable temperature to keep the quality of the food.

According to Walker (2011), the safety and suitability of food need to be maintained by ensuring it is stored in an appropriate environment and protected from contamination. Potentially hazardous food must be stored at a temperature that minimizes the opportunity for pathogenic bacteria to grow. Part of the food production system is to store food and other supplies so that they fit into the overall system. This means storage arranged for easy receiving, easy issuing and easy inventory control. In the dry-goods storeroom, canned, packed and bulk dry foods are stored according to usage. The most-used foods are stored closest to the door, the least-used foods in the less accessible corners and shelves. Once a system of storage has been arranged and the items are stored according to usage, a form can be made up listing the items in the sequence in which they are stored.

As the foods are received, they are stored at the backs of the shelves, the older items moved forward to be used first. This rotational system helps to ensure that all the items are not allowed to become too old. For convenience foods usually come in a form that makes it possible for them to be stored in a minimal amount of space. Other items are received in a form that should be processed immediately to reduce the amount of storage needed.

Many food operators buy only salad greens that have already been washed and cut. Both time and space are saved, but the quality may be lower than if the greens were prepared on the premises. To ensure freshness, frequent turnover is essential. To maximise the shelf life of a product, it is important to store all items at the correct temperature. Suitable storage temperature for dry storage is 23°C, for meat and poultry is 4°C, for dairy products is 4°C, for seafood is 4°C and for frozen food is below -17°C. The food premise operators or the managers should be presents at delivery times and see that everything is properly stored. (Walker, 2011)

4.0 METHODOLOGY

Data collection method using documents contains text (words) and images that have been recorded without a researcher's intervention. According Bowen (2009), document analysis is a form of qualitative research in which documents are interpreted by the researcher to give voice and meaning around an assessment topic. Analyzing documents incorporates coding content into themes similar to how focus group or interview transcripts are analyzed.

There are many reasons why the researcher chooses to use document analysis. Firstly, documents analysis is an efficient and effective way of gathering data because documents are manageable and practical resources. Documents are commonplace and come in a variety of forms, making documents a very accessible and reliable source of data. Bowen (2009) also mentioned that obtaining and analyzing documents is often far more cost-efficient and time-efficient than conducting your research or experiments.

According to O'Leary (2017), there are three primary types of documents which are public records, personal documents and physical evidence. Data collection method that been used by researcher to conduct this research is by using the document analysis. The researcher selected a few selected documents for this analysis. This analysis is really important for the researcher to come out with a clear understanding of the halalan tayyiban concept. The document used in this research is the Manual Procedure for Malaysia Halal Certification (Third Revision) 2014.

5.0 RESULTS

This section is to explore the concept of halal by using the documents of Manual Procedure for Malaysia Halal Certification (Third Revision) 2014 which includes the four aspects for halalan tayyiban concept which are pure, hygiene, safe and quality. The Manual Procedure for Malaysia Halal Certification (Third Revision) 2014 (MPPHM 2014) contains guidelines for Department of Islamic Development Malaysia (JAKIM) and the States Department of religious Affairs (JAIN) and Islamic Religious Affairs Council (MAIS) Inspection Officers, intending to clarify requirements to be complied with, in managing the Malaysia Halal Certification. (extract from the MPPHM 2014). Table 1.0 below shows the categories that are related to the four aspects in halalan tayyiban practices found in MPPHM 2014.

Table 1.0: Aspects of halalan tayyiban practices that found on MPPHM 2014

Aspect	Chapter	Category
Pure	2.3.2.i.a	The definition of halal
	2.3.2.i.b	The definition of halal
	2.3.2.i.g	The definition of halal
	5.1.ii	Requirements for raw material
	5.1.vi	Requirements for raw material
	5.2.iii	Requirements for processing
Hygiene	5.2.v	Requirements for processing
	2.3.2.i.f	The definition of halal
	2.4.1	The definition of <i>najs</i>
	5.2.ii	Requirements for processing
	5.6.i	Requirements for worker
	5.6.ii	Requirements for worker
	5.7.i	Requirements for sanitation system (Environment)
5.7.ii	Requirements for sanitation system (Equipment)	
5.7.iii	Requirements for sanitation system (Pest Control)	
Safe	2.3.2.i.c	The definition of halal
	5.1.i	Requirements for raw material
	5.5.i	Requirements for a food premise
	5.5.iii	Requirements for a food premise
	5.9	Requirements for workers' basic amenities and welfare
Quality	5.1.i	Requirements for raw material
	5.1.iii	Requirements for raw material
	5.1.iv	Requirements for raw material
	5.3.ii.f	Requirements for packaging and labelling

5.1 Pure

Pure has been mentioned a lot of times in the MPPHM 2014 especially in foods operations. The first aspect that related to pure in halal concept is the definition of halal itself in the MPPHM 2014 that can be found at 2.3.2.i.a which is when food or goods are described as halal are neither is nor consist of or contains any part or matter of an animal that is prohibited by Shari'ah law for a Muslim to consume or that has not been slaughtered by Syari'ah law and Fatwa. That definition of halal is shown that a Muslim should only consume that is pure in terms of Shari'ah law such as cow, lamb and so on that has been slaughtered in Shari'ah way. Other than that, the aspect of pure can be seen at 2.3.2.i.b which describes the meaning of halal that foods or goods do not contain anything impure or *najs* according to Shari'ah law and Fatwa. That definition from MPPHM 2014 clearly describes that halal foods or goods should be free from many *najs* or impurity such as blood, urine and faeces. The aspect of pure also can be seen at 2.3.2.i.g which also describes the meaning of halal which is foods or goods should not be contacted or mixed with any prohibited animals and *najs* and impurity elements.

On the general requirements for certification in MPPHM 2014 the aspect of pure can be seen at 5.1.ii which describes the requirements of raw material, ingredients should be sourced from the animal that has a valid halal certificate. The raw material and ingredient should be taken from suppliers that obtained valid halal certificate only.

For the processing part, aspect of pure on the general requirements for certification in MPPHM 2014 also can be seen at 5.1.vi which stated that non-halal raw material and ingredients are not allowed to be stored in the premise. This means that the food premise that wanted to apply for halal certification has to make sure that they do not have any raw material and ingredients that source from non-halal sources. Other than that aspect of pure can also be found at 5.2.iii which stated that raw material and products should not be mix with the non-halal material or sources or those with uncertain halal status. At 5.2.v also mentioned about the aspect of pure which is any appliances and brushes from animal hair is not allowed.

On the general requirements for certification in MPPHM 2014 for a food premise, aspects of pure can be found at 5.5.ii which is any appliances or brushes from animal hair are not allowed. While on 5.5.v have stated that non-halal food or beverages are not allowed to be brought into the premise. At 5.5.viii also mentioned that liquor and materials sourced from liquor is strictly prohibited to be in the halal kitchen and hotel including the storage area. This means that the food premise should be free from anything related to non-halal source be in the kitchen or the storage area.

5.2 Hygiene

The aspect of hygiene has been mentioned a lot of times in the MPPHM 2014 especially in foods operations. The first aspect that related to hygiene in halalan tayyiban concept is the definition of halal itself in the MPPHM 2014

that can be found at 2.3.2.i.f which stated about the foods and goods should not be processed, prepared or manufactured with any instrument that is contaminated with *najs* according to Shariah law and Fatwa. This means that halal foods and goods should not be mixed or contact with anything that is *najs*. *Najs* according to the MPPHM 2014 is impurity such as blood, urine and faeces that can be found at 2.4.1.

For the processing part, aspect of hygiene on the general requirements for certification in MPPHM 2014 also can be found at 5.2.ii which stated that during the preparation, handling, processing, packaging, storage or transfer of products, it should be compliance to Shariah law and remain clean well as comply with Good Manufacturing Practice (GMP) and Good Hygienic Practices (GHP).

Other than that, on the general requirements for certification in MPPHM 2014 for the worker, aspects of hygiene can be found at 5.6.i which stated that all workers should practice code of ethics and Good Hygienic Practices (GHP) as stated in the Food Hygiene Regulations 2009 and other related regulations. At 5.6.ii also mentioned about the attire of the worker which is the worker should wear proper and suitable attire.

On the general requirements for certification in MPPHM 2014 for sanitation system, the aspect of hygiene can be found at 5.7.i which mentioned about the environment of the food premise. The environment of the food premise should be clean and its cleaning schedule should be properly regulated and free from pollution. Other than that, the aspect of hygiene also can be found at 5.7.ii that mentioned about the equipment of the food premise. The equipment should be clean and sanitary, the equipment, machine appliances and processing aids which have been used or in contact with *najs mughallazah* shall be religiously cleansed (*sertu*) and appliances and brushes from animal sources are not allowed. At 5.7.iii also mentioned about the hygiene aspect which related to pest control and it stated that applicants shall have records of regular pest control system conducted by the company itself or contracted externally.

5.3 Safe

The aspect of safe has been mentioned a lot of times in the MPPHM 2014 especially in foods operations. The first aspect that related to safe in halalan tayyiban concept is the definition of halal itself in the MPPHM 2014 that can be found at 2.3.2.i.c which stated about the foods and goods do not intoxicate according to Shariah law and fatwa. This is because intoxicate foods or drinks could harm your minds and body and to protect that intoxicated foods or drinks is prohibited in Islam which it includes the protection of mind (*aql*) in *Maqasid Shariah*.

On the general requirements for certification in MPPHM 2014 for raw materials and ingredients, the aspect of safe can be found at 5.1.i which mentioned about the sources of raw material and ingredients must be halal and safe.

On the general requirements for certification in MPPHM 2014 for a food premise, aspects of safe can be found at 5.5.i which is the equipment used shall be free from *najs*, does not contain any hazardous material and results in side effects to the products produced. Other than that, aspect of safe also has been mentioned at 5.5.iii which stated that the arrangement of equipment and goods in the factory shall be neat, tidy and safe.

On the general requirements for certification in MPPHM 2014 for worker's basic amenities and welfare, aspects of safe can be found at 5.9 which mentioned about the management shall provide basic amenities and ensure the worker's welfare is taken care of including a suitable praying area for Muslim workers, permission to perform daily prayers and Friday prayers, changing room and pantry. These basic amenities allowed workers to have their rights while working at the food premise.

5.4 Quality

On the general requirements for certification in MPPHM 2014 for raw materials and ingredients, the aspect of quality can be found at 5.1.i which stated that the raw material and ingredients should come from halal and safe sources. Other than that aspect of quality can be found at 5.1.iii which mentioned about the sources of imported animal-based raw materials shall come from approved plants by JAKIM and Department of Veterinary Services (DVS). The aspect of quality also can be found at 5.1.iv which stated that raw material without halal certification shall be accompanied with complete specification (indicating material composition, flow chart and its raw material sources). Other than that, aspect of quality also can be found at 5.3.ii.f that mentioned about the packaging label shall contain coding number to show the date and/or production batch number and expiry date. (JAKIM, 2015)

6.0 CONCLUSION

In conclusion, the Manual Procedure for Malaysia Halal Certification Third Revision 2014 (MPPHM 2014) is a comprehensive guideline that was designated by the Malaysian government to secure the halal application system in Malaysia. This is the high determination shown by the industry for the manufacturer to comply with the procedure and the process of halal certification that is transparent and reliable that covered all of the four aspects of halal practices.

Even though halal is based on volunteerism but it is reminded for all the manufacturer to apply for the halal certification because of the assurance of the system that includes those four aspects which are pure, hygiene, quality and safe are well regulated.

MPHHM also helps the manufacturer to understand more on the halalan tayyiban practices that covered those four aspects in halalan tayyiban. Hence, this would help increase the awareness and understanding of the wholesome halalan tayyiban practices that not just focused solely on the ingredients but as well as the input, output and the process as a whole. At the same time, it would also help increase the consumers' confidence and understanding in choosing the halal products in the future.

7.0 RECOMMENDATIONS

7.1 The Enhancement of the Mentoring and Training Modules

The mentoring and training modules to develop entrepreneurs that produce products that achieved halalan tayyiban concept is still far from realization. Even though there are so many people who proclaim their determination in the mentoring and the training aspect, the quality of the results is yet to be improved. Mostly the modules that have been used were the 'recycle' modules' from the previous sessions. The involvements from the Islamic scholars and the expert in the halal industry were much needed in the improvement of this industry.

7.2 Promoting the Halal Certification

The authority that works closely with halal certification plays an important role in promoting the halal certification. They should encourage manufacturers and entrepreneurs to apply the halal certification effectively. In promoting the halal certification, JAKIM preferably should include the four main aspects of the halalan tayyiban concept. Awareness to the public about halal certification that contains all those four main wholesome practices and universal values is very much needed because the majority of consumers were misunderstood the concept of halal because is not just a logo that is free from unlawful ingredients but it includes wholesome practices and universal values like pure, hygiene, safe and quality.

REFERENCE

- al-Qaradawi, Y. (2013). *The Lawful and the Prohibited in Islam: الحلال والحرام في الإسلام*. Retrieved from <https://books.google.com.my/books?id=iXCNAQAQBAJ>
- Azam-Ali, S. (2003). *Small-scale food processing: a directory of equipment and methods /compiled by Sue Azam-Ali .. [et al.]*. – National Library. ITDG Publishing.
- Bashir, K. M. I., Kim, J.-S., Mohibbullah, M., Sohn, J. H., & Choi, J.-S. (2019). Strategies for improving the competitiveness of Korean seafood companies in the overseas halal food market. *Journal of Islamic Marketing*, 10(2), 606–632. <https://doi.org/10.1108/JIMA-03-2018-0056>
- Bowen, G. A. (2009). Document analysis as a qualitative research method. *Qualitative Research Journal*, 9(2), 27–40. <https://doi.org/10.3316/QRJ0902027>
- Codex Alimentarius Commission. (2008). Report of the seventh session of the codex ad hoc intergovernmental task force on foods derived from biotechnology - Alinorm 08/31/34. *Biotechnology*, (September 2007), 24–28.
- JAKIM. (2015). Manual Procedure for Malaysia Halal Certification (Third Revision) 2014. *Jabatan Kemajuan Islam Malaysia (JAKIM)*, p. 67. Retrieved from www.islam.gov.my
- Kosmo. (2016). WHO | Food hygiene. *Kosmo*. Retrieved from https://www.who.int/foodsafety/areas_work/food-hygiene/en/
- Lelieveld, H., Holah, J., & Gabrić, D. (2016). Handbook of Hygiene Control in the Food Industry. In *Handbook of Hygiene Control in the Food Industry: Second Edition*. <https://doi.org/10.1016/C2014-0-01825-4>
- Marriott, N. G., & Gravani, R. B. (2006). *Principles of Food Sanitation Fifth Edition*. SPRINGER.
- Walker, J. R. (2011). *The Restaurant from Concept to Operation* (Sixth Edit). United States of America: John Wiley & Sons, Inc.
- Zainol, Z., Yahaya, R., Osman, J., & Omar, N. A. (2019). Application of the Tayyib concept among Malaysian muslim consumers: The role of nutrition label. *Journal of Islamic Marketing*, 11(3), 819–840. <https://doi.org/10.1108/JIMA-03-2018-0048>
- Zannierah Syed Marzuki, S., Hall, C. M., & Ballantine, P. W. (2012). Restaurant managers' perspectives on halal certification. *Journal of Islamic Marketing*, 3(1), 47–58. <https://doi.org/10.1108/17590831211206581>

INVESTORS' HERDING PROPENSITY IN ISLAMIC FINANCIAL MARKET: A REVIEW

Moh'd Lawal Danriri^a & Salisu Isyaku^b

^aDepartment of Accounting, Faculty of Social and Management Sciences, Umaru Musa Yar'adua University, Katsina, Nigeria.

^bDepartment of Decision Science, Universiti of Utara Malaysia

ABSTRACT

Among the growing concerns about potential financial stability risks posed by investors' behavioral anomalies, herding behavior has been considered as an important risk amplification channel. Based on this assumption, this study reviews prior academic literature on investors' herding practice in both conventional and Islamic financial markets, published in prominent academic journals. This is done with a view to examining the extent to which behavioral finance scholars address this investors' destabilizing behavior in these distinct financial markets. Drawing on this review, this study finds that despite an enormous interest in studying investors' herding tendency and its resultant effects that affect even the world Islamic financial markets, no much attention is paid in examining the presence of herding behavior in Islamic financial markets. Hence, the perception that herding practice in ethically and socially responsible market, such as Islamic financial market, maybe limited or non-existence still remains an unresolved hypothesis. To this end, this study tries to expand the extant literature by drawing the attention of behavioral finance researchers on the need to also exert energy on investigating the evidence of herding behavior in Islamic financial market, an issue that has been largely ignored in Islamic finance network. Understanding this phenomenon would bear some important implications for regulators and policy makers to enable them put mechanism in place to mitigate the adverse effect of this destabilizing risk factor.

Keyword: Herding; Islamic Financial Market; Conventional Financial Market; Behavioral Finance.

JEL CODE: G14; G15; M41

1.0 INTRODUCTION

Herding as a behavioural pattern, is the tendency of investors to mimic the observed action of others, even when their private signal suggests otherwise (Garg & Jindal, 2014; Golarzi & Ziyachi, 2013; Kashif et al. 2020; Spyrou, 2013). On the premise that basing their own decision based on the available information is likely to incur more cost and less benefit (Duasa & Kassim, 2008). The activities of this class of traders have often been seen as the reason why market decline fuels further market decline and market increase fuels further market increase (Coskun et al. 2020; Lakonishok, Shleifer, & Vishny, 1992), hence, leading to excessive volatility in the financial markets (Bowe & Domuta, 2004), as well as economic bubbles and ultimately market crashes (Golarzi & Ziyachi, 2013). It is for this reason Wang (2008) argues that herding phenomenon is perhaps one of the most widely noticed but least understood investors' behavioral bias in the financial market lexicon, thus, difficulties in testing its existence remains an obstacle in the extant literature.

While a plethora of studies have attempted to examine investors' herding tendency, its geneses, effects, and measurements (Balcilar, Demirer, & Hammoudeh, 2014; Bohl, Klein, & Siklos, 2014; Cajueiro & Tabak, 2009; Economou, Gavrilidis, Goyal, & Kallinterakis, 2015; Galariotis, Rong, et al., 2015; Hou, McKnight, & Weir, 2013; Hwang & Salmon, 2001; Klein, 2013; Lin & Lin, 2014), it is glaring that the existing literature is skewed towards conventional financial markets, with little or no attention to its Islamic counterparts. This is particularly worrisome, because if this phenomenon remains unchecked, the stability and the resiliency arguably demonstrated by Islamic financial industry might be susceptible. Finance researchers have since express serious concerns about the fragility of herd behaviour in financial markets. As the phenomenon tends to exacerbate market volatility, decay market stability, and impair the accurate and better functioning of financial markets (Kremer & Nautz, 2013; Clements, Hum, & Shi, 2017; Fernández, Garcia-Merino, Mayoral, Santos, & Vallelado, 2011; Kremer & Nautz, 2013).

This study, therefore, argues that the fragility and negative effect of herding phenomenon make it not only imperative but also compelling for Islamic finance researchers to direct their attention towards testing this destabilizing investment behaviour in Islamic finance network. With a view to providing valuable insight to policy

makers to put mechanisms in place in order to mitigate the adverse effect of this behavioural bias. So that the expectation that Islamic financial market which is characterized by ethically-oriented trade (Jawadi, Jawadi, & Louhichi, 2014), socially responsible investment (Al-Khazali, Lean, & Samet, 2014), and epic regulated system, maybe immune from investors' herding anomaly, would not be over exaggerated. In other words, the assumption that Islamic finance investment maybe insulated from the waving range of herding phenomenon, still remains a hypothesis that needs to be tested.

2.0 METHODOLOGY

This study adopts systematic literature review methodology to examine and analyse articles related to behavioural biases in investment decision-making, with specific focus to investors' herding bias. At first, the study considered only scholarly articles published from the year 2007. This period was chosen because it was a period when the world experienced general economic meltdown; leading to excessive volatility, economic bubbles and ultimately market crashes in many countries. However, the scope was stretched to include selected scholarly articles published before 2007 due to their significance to the set research objectives. Furthermore, the articles considered are largely from the world's leading academic journals included in the Social Science Citation Index (SSCI) database. The SSCI receives global recognition to the extent that some countries use it to evaluate researchers' productivity (Lourenço, Branco, & Castelo, 2015). The following table summarizes the relevant articles reviewed per journal and year of publication.

3.0 EVIDENCE OF HERDING BEHAVIOUR IN THE FINANCIAL MARKETS

Numerous empirical studies have attempted to examine investors' herding tendency, its geneses, effects and measurements. These empirical studies are often classified into two broad categories (Messis & Zapranis, 2014; Yao et al., 2014). The first category focuses on investigating the herding behaviour of certain form of investors, such as financial analysts and mutual fund managers (Chang, 2010; Kim & Nofsinger, 2005; Lakonishok et al., 1992; Sias, 2004). The other category, focuses on testing the market wide herding using aggregate market data (Chang et al., 2000; Chiang & Zheng, 2010; Christie & Huang, 1995; Tan et al., 2008; Galarotis, Krokida, et al., 2015). Although, the findings in these growing studies are mixed, one thing that clear is that the studies focus at detecting herding behaviour in conventional financial market. The present study is however based on the latter approach and focuses on Islamic financial market.

Studies on the market-wide approach normally focus on cross-sectional correlated stocks return dispersion in respond to changes in the market conditions. A study of Christie and Huang (1995) (hereafter CH) has often been considered as one of the pioneering studies of this category. CH argue that investors' decision-making process is largely determined by the overall market situations. During abnormal information flows or extreme market movement, individual investors tend to ignore their own private information signal and search for market-wide consensus in order to modify their own beliefs regarding their own private information. In consequence, individual returns tend to cluster around the overall market returns.

To test the presence of herding, CH proposed a model that uses cross-sectional standard deviation (CSSD) as a measure of average proximity of individual as set returns to the realized market average, using daily and monthly data set of US quoted firms from 1962 to 1988 and 1925 to 1988 respectively. Although the findings from the two set of data are not consistent with the existence of herding during period of abnormal information flows, their model has been recognised and recommended as suitable for measuring herding.

However, Chang et al. (2000) contend that the linear relationship between return dispersion and market return as proposed by CAPM, would no longer hold during extreme market movement. They explain that, the possibility of investors to comfort to market consensus during this period is sufficient to change the linear relationship into non-linear one. To address this effect, Chang et al. (2000) extend CH's herding measure to gauge investors' herding tendency in both developed and emerging financial markets. The measure uses cross sectional absolute deviation (CSAD) to quantify the degree of return dispersions relative to overall market returns. The empirical finding indicates that during market stress, security return dispersions appear to linearly increase for Hong Kong and US, hence indicating no evidence of herd behaviour. However, partial evidence is recorded in the case of Japan, while for Taiwan and South Korea the two emerging markets the study reports significant non-linear relationship, thus, indicating significant presence of herding.

Table 4: Distribution of Articles Examining Investors' Herding Behavior in Financial Market Per Journal and Year of Publication

Journal	2005	2006	2007	2008	2009	2010	2011	2012	2013	2014	2015	2016	2017	2018	2019	2020	
Accounting and Finance Research								1									1
Chaos, Solitons & Fractals					1												1
Decision									1								1
Finance Research Letters												1					1
International Economics										1							1
International Journal of Business and Management																	0
International Journal of Emerging Markets											1						1
International Journal of Finance & Economics																2	2
International Review of Economics & Finance										2	1						3
International Review of Financial Analysis										1	1						2
International Review of Financial Analysis											1						1
Islamic Economics											1						1
Journal of Applied Economic Sciences				1													1
Journal of Applied Finance										1							1
Journal of Applied Sciences								1									1
Journal of Banking & Finance	1					1					1	1					4
Journal of Banking & Finance									3								3
Journal of Business Studies Quarterly								1									1
Journal of Contemporary Eastern Asia,																1	1
Journal of Economic Behavior & Organization						1											1
Journal of Empirical Finance	1																1
Journal of Empirical Finance					1												1
Journal of International Financial Markets, Institutions and Money		1		1			1		2	1	1						7
Journal of Open Innovation: Technology, Market, and Complexity											2						2
Pacific-Basin Finance Journal	1			1		1											3
Qualitative Research in Financial Markets							1										1
Qualitative Research in Financial Markets							1										1
Research in International Business and Finance												1					1
Research in International Business and Finance																1	1
Review of Behavioral Finance									1								1
Revista de Contabilidad											1						1
Strategic Organization																1	1
Studies in Economics and Finance										1							1
The Journal of Business	1																1
The Journal of Risk Finance										1							1
The North American Journal of Economics and Finance										1							1
Total	4	1	0	3	2	3	3	3	7	9	10	3	0	0	0	5	53

Mobarek et al. (2014) investigate country specific herding in European financial markets for the period of 2001-2012. While the results illustrate limited evidence of herding for the whole sample period, it however, reports significant evidence of herding during crisis and asymmetric market conditions. Consistently, Klein (2013) examines time-variations in herding behaviour in the US and Euro-area stock markets. The finding of the study also seems to lend credence to the claim that herding behaviour is likely to be more pronounced during period of abnormal information flows and extreme market movement. Specifically, the finding shows significant evidence of herding during crisis period like; the global financial crisis and after dot.com bubble. Loang and Ahmad (2020) examine the existence of herd behaviour in fifteen (15) global stock markets, which consist of Developed Markets (Canada, Hong Kong, Japan, Singapore and the United Kingdom), Advanced Emerging Markets (Brazil, Malaysia, Mexico, Poland and South Africa) and Secondary Emerging Markets (Chile, China, Indonesia, the Philippines and Russia) by using Cross Sectional Absolute Deviation (CSAD) method of Chiang and Zheng (2010). The findings reveal that indicate that herd behaviour exists in Singapore (Developed Market), Mexico, Poland and South Africa (Advanced Emerging Markets) and China and the Philippines (Secondary Emerging Markets). No evidence of herding is observed for Canada, Hong Kong, Japan, United Kingdom, Brazil, Malaysia, Chile, Indonesia and Russia.

In the contrary, Hwang and Salmon (2004) developed an alternative approach that uses cross-sectional dispersion of factor sensitivity of assets as a proxy for herding behaviour. The result of the study indicates evidence of herding in both periods of market tranquillity and period of market stress, and thus contradicts the common beliefs that herding is more likely to prevail in a period when market is in turbulence. In their study, Economou et al. (2011) examine investors' herding tendency in four international markets from 1998 to 2008, using daily stock returns of the chosen (Greek, Spanish, Italian and Portuguese) markets. The results reveal evidence of herding in Greek and Italian markets. While the effect is mixed in Portugal, no herding effect is recorded in the Spanish market. In line with this finding, Simões Vieira and Valente Pereira (2015) also provide mixed evidence using two different herding measures in their analysis of stocks that forms the Portuguese stock PSI-20 index. The authors argue that the mixed findings reported indicates that different herding measure may result in different conclusion about the presence of herding behaviour, and thus call for more methodical rethink in the future studies.

Corroborating the above findings, Riza Demirer, Kutun, and Chen (2010) employ three different herding measures and reports mixed findings, using daily stock returns of 689 Taiwanese firms quoted on the Taiwan Stock market. Galariotis, Rong, et al. (2015) examine European bond market in investors' herding following the European financial crisis and report no evidence of herding either before or after the EU financial crisis. Chiang and Zheng (2010) provide one of the comprehensive evidence of herding phenomenon from 18 different stock markets that cut across different continents, covering the periods between 1988 and 2009. The findings reveal that with the exception of the US, there exists significant evidence of herding behaviour in the developed market and in Asia markets. However, no evidence is recorded in Latin American stock markets. Furthermore, while, the phenomenon is found to be more pronounced in Asia during the up market, the authors argue that financial crisis intensified the herding phenomenon in the countries where the crisis originated and then produces spill over effects to the neighbouring countries. Moreover, during the crisis periods the study finds strong evidence of herding in the US and Latin American markets.

In their study, Prosad et al. (2012) consider 5 years Nifty 50 Indian stock data between 2006 and 2011 to detect the market wide herding and then herding during bull and bear market separately. The result documents non evidence of herding between 2006 and 2011 based on the market wide analysis. However, the separate test during bull and bear market indicates the prevalence of herding during the bull phase, but no evidence of herding during the bear phase. Using a sample of 25 American quoted companies on the Dow Jones index Belhoula and Naoui (2011) confirm the evidence of herding by the investors of the sampled companies. In their study Messis and Zapranis (2014) use cross sectional variance of beta to test the existence of herding and its likely effects on market volatility on some selected stocks traded on the Athens Stock Exchange. The result reveals evidence of herding over the periods under consideration and also indicates that stocks exhibiting strong evidence of herding also tend to exhibit high evidence of volatility.

Gaboriet al. (2020) investigates the influence of oil market volatility and hand-picked OPEC meetings data on herding tendency in the Saudi equity market. Their results show the presence of significant herding behaviour in the Saudi market; amazingly this herding behaviour is independent of oil market volatility. Notably, they find herding on and around the OPEC meeting days however this is only limited to a period of high global uncertainty that is, during the Global Financial Crisis period (GFC) of 2008–2010. Given that the foregoing evidence of herding stems mainly from conventional financial markets, one can establish a strong argument that the stability and resilience demonstrated by Islamic financial market, couple

with its epic regulatory system, is likely to promote information based-trading and mitigate investors' herding tendency. But whether this is the case, remains an empirical question.

4.0 FINDINGS AND THE RESEARCH GAPS

Review of the extant literature reveals that there has been little attempt to explore the evidence of herding phenomenon in Islamic financial markets. Surprisingly, despite the keen interest in studying investors' herd behaviour, especially in the aftermath of global financial meltdown, and the associated contagious effects that affect even world Islamic equity markets, no attention is paid to examine the presence of this destabilizing behaviour in Islamic financial markets. Hence, the perception that herding phenomenon in ethically and socially responsible market, maybe limited or non-existence still remains an untested hypothesis. Thus, this study attempts to fill this gap by providing an early evidence of this destabilizing phenomenon in Islamic finance network. And provide useful insight not only to investing community, but also for regulatory authorities and academics.

5.0 CONCLUSION

The aim of this paper is to determine the effect of herding bias on investors' investment decision-making and to address the question as to whether investors' herding tendency exists towards Islamic financial securities. The analysis and discussion of studies reveal that the issue of investors herding propensity in Islamic financial market has been largely ignored in Islamic finance network. Nonetheless, regardless of the underlying market, there are two vital reasons why studying investors' herding behavior in financial market is important. First, the phenomenon is reported to have a potential effect of distorting the stability of financial market. Thus, understanding this phenomenon would bear some important implications for regulators and policy makers, by enabling them to put mechanism in place to mitigate the adverse effect of this destabilizing phenomenon. Second, as the presence of herding is likely to impede Islamic investors' confidence that consider Islamic securities as viable investment option, the findings of this study would provide them with the basis to use empirical finance research to arrive at rational investment decision, through the use of market fundamental variables, treating them as principal indicators for future market movement.

REFERENCES

- Al-Khazali, O., Lean, H. H., & Samet, A. (2014). Do Islamic stock indexes outperform conventional stock indexes? A stochastic dominance approach. *Pacific-Basin Finance Journal*, 28, 29-46.
- Angela-Maria, F., Maria, P. A., & Miruna, P. M. (2015). An empirical investigation of herding behavior in CEE stock markets under the global financial crisis. *Procedia Economics and Finance*, 25, 354-361.
- Antonioni, A., Koutmos, G., & Pericli, A. (2005). Index futures and positive feedback trading: evidence from major stock exchanges. *Journal of Empirical Finance*, 12(2), 219-238.
- Babajide, A. A., & Adetiloye, K. A. (2012). Investors' behavioural biases and the security market: An empirical study of the Nigerian security market. *Accounting and Finance Research*, 1(1), 219-229.
- Bakar, S., & Yi, A. N. C. (2016). The Impact of Psychological Factors on Investors' Decision Making in Malaysian Stock Market: A Case of Klang Valley and Pahang. *Procedia Economics and Finance*, 35, 319-328.
- Balcilar, M., Demirer, R., & Hammoudeh, S. (2014). What drives herding in oil-rich, developing stock markets? Relative roles of own volatility and global factors. *The North American Journal of Economics and Finance*, 29(0), 418-440.
- Belhoula, M., & Naoui, K. (2011). Herding and Positive Feedback Trading in American Stock Market: A Two Co-directional Behavior of Investors. *International Journal of Business and Management*, 6(9), 244-252.
- Bernales, A., Verousis, T., & Voukelatos, N. (2016). Do investors follow the herd in option markets? *Journal of Banking & Finance*.
- Bohl, M. T., Klein, A. C., & Siklos, P. L. (2014). Short-selling bans and institutional investors' herding behaviour: Evidence from the global financial crisis. *International Review of Financial Analysis*, 33, 262-269. doi:http://dx.doi.org/10.1016/j.irfa.2014.03.004
- Bowe, M., & Domuta, D. (2004). Investor herding during financial crisis: A clinical study of the Jakarta Stock Exchange. *Pacific-Basin Finance Journal*, 12(4), 387-418.
- Cai, F., Han, S., & Li, D. (2012). Institutional herding in the corporate bond market.
- Cajueiro, D. O., & Tabak, B. M. (2009). Multifractality and herding behavior in the Japanese stock market. *Chaos, Solitons & Fractals*, 40(1), 497-504.
- Clements, A., Hum, S., & Shi, S. (2017). An empirical investigation of herding in the US stock market. *Economic Modelling*.
- Fernández, B., Garcia-Merino, T., Mayoral, R., Santos, V., & Vellido, E. (2011). Herding, information uncertainty and investors' cognitive profile. *Qualitative Research in Financial Markets*, 3(1), 7-33.
- Gabbori, D., Awartani, B., Maghyereh, A., & Virk, N. (2020). OPEC meetings, oil market volatility and herding behavior in the Saudi Arabia stock market. *International Journal of Finance & Economics*. Pp. 1-19. doi: 10.1002/ijfe.1825.
- Galariotis, E. C., Krokida, S.-I., & Spyrou, S. I. (2015). Bond Market Investor Herding: Evidence from the European Financial Crisis. *International Review of Financial Analysis*(0). doi:http://dx.doi.org/10.1016/j.irfa.2015.01.001
- Kashif M., Palwishah, R., Ahmed, R. R., Vveinhardt, J., & Streimikiene, D. (2020). Do investors herd? An examination of Paki stan stock exchange. *International Journal of Finance & Economics*. Pp. 1-16. doi: 10.1002/ijfe.1895.
- Coskun, E. A., Lau, C. K. M., & Kahyaoglu, H. (2020). Uncertainty and herding behavior: evidence from cryptocurrencies. *Research in International Business and Finance*. 54, 1-17. doi.org/10.1016/j.ribaf.2020.101284.
- Kremer, S., & Nautz, D. (2013). Causes and consequences of short-term institutional herding. *Journal of Banking & Finance*, 37(5), 1676-1686.
- Lee, S., & Lee, K. (2015). Heterogeneous expectations leading to bubbles and crashes in asset markets: Tipping point, herding behavior and group effect in an agent-based model. *Journal of Open Innovation: Technology, Market, and Complexity*, 1(1), 11.
- Lütje, T., & Menkhoff, L. (2003). Risk Management, Rational Herding and Institutional Investors: A Macro View. *University of Hannover, Discussion paper*(285).
- Szyszka, A. (2011). Behavioral anatomy of the financial crisis.
- Chang, Cheng, J. W., & Khorana, A. (2000). An examination of herd behavior in equity markets: An international perspective. *Journal of Banking & Finance*, 24(10), 1651-1679.
- Chang, C. (2010). Herding and the role of foreign institutions in emerging equity markets. *Pacific-Basin Finance Journal*, 18(2), 175-185.
- Chang, C. H., & Lin, S.-J. (2015). The effects of national culture and behavioral pitfalls on investors' decision-making: Herding behavior in international stock markets. *International Review of Economics & Finance*, 37, 380-392.
- Chiang, T. C., & Zheng, D. (2010). An empirical analysis of herd behavior in global stock markets. *Journal of Banking & Finance*, 34(8), 1911-1921.
- Christie, W. G., & Huang, R. D. (1995). Following the pied piper: Do individual returns herd around the market? *Financial Analysts Journal*, 31-37.
- Daher, H., Masih, M., & Ibrahim, M. (2015). The unique risk exposures of Islamic banks' capital buffers: A dynamic panel data analysis. *Journal of International Financial Markets, Institutions and Money*, 36, 36-52.
- Demirer, R., & Kutun, A. M. (2006). Does herding behavior exist in Chinese stock markets? *Journal of International Financial Markets, Institutions and Money*, 16(2), 123-142.
- Demirer, R., Kutun, A. M., & Chen, C.-D. (2010). Do investors herd in emerging stock markets?: Evidence from the Taiwanese market. *Journal of Economic Behavior & Organization*, 76(2), 283-295.
- Duasa, J., & Kassim, S. (2008). Herd behaviour in Malaysian capital market: An empirical analysis. *Journal of Applied Economic Sciences*, 4(1)(7).
- Economou, F., Gavriilidis, K., Goyal, A., & Kallinterakis, V. (2015). Herding dynamics in exchange groups: Evidence from Euronext. *Journal of International Financial Markets, Institutions and Money*, 34(0), 228-244.
- Economou, F., Katsikas, E., & Vickers, G. (2016). Testing for herding in the Athens Stock Exchange during the crisis period. *Finance Research Letters*, 18, 334-341.
- Economou, F., Kostakis, A., & Philippas, N. (2011). Cross-country effects in herding behaviour: Evidence from four south European markets. *Journal of International Financial Markets, Institutions and Money*, 21(3), 443-460.
- Fernández, B., Garcia-Merino, T., Mayoral, R., Santos, V., & Vellido, E. (2011). Herding, information uncertainty and investors' cognitive profile. *Qualitative Research in Financial Markets*, 3(1), 7-33.
- Galariotis, E. C., Krokida, S.-I., & Spyrou, S. I. (2015). Bond Market Investor Herding: Evidence from the European Financial Crisis. *International Review of Financial Analysis*(0).
- Galariotis, E. C., Rong, W., & Spyrou, S. I. (2015). Herding on fundamental information: A comparative study. *Journal of Banking & Finance*, 50(0), 589-598.
- Garg, A., & Gulati, R. (2013). Do investors herd in Indian market. *Decision*, 40(3), 181-196.

- Garg, A., & Jindal, K. (2014). Herding Behavior in an Emerging Stock Market: Empirical Evidence from India. *IUP Journal of Applied Finance*, 20(2), 18-36.
- Gelos, R. G., & Wei, S.-J. (2002). *Transparency and international investor behavior*. Retrieved from
- Golarzi, G., & Ziyachi, A. (2013). Study of the Herding Behaviors of Investors in the Tehran Stock Exchange (TSE): a Trading Volume Approach. *Interdisciplinary Journal of Contemporary Research In Business*, 5(4), 196-206.
- H. Ibrahim, M., & Sufian, F. (2014). A structural VAR analysis of Islamic financing in Malaysia. *Studies in Economics and Finance*, 31(4), 371-386.
- Hou, T. C.-t., McKnight, P. J., & Weir, C. (2013). Mutual Fund Herding in Taiwan. Rochester: Social Science Research Network.
- Hussin, M. Y. M., Muhammad, F., Abu, M. F., & Awang, S. A. (2012). Macroeconomic variables and Malaysian Islamic stock market: a time series analysis. *Journal of Business Studies Quarterly*, 3(4),
- Hwang, S., & Salmon, M. (2001). A new measure of herding and empirical evidence for the US, UK, and South Korean stock markets. *Financial Econometrics Research Centre*, 1, 12.
- Hwang, S., & Salmon, M. (2004). Market stress and herding. *Journal of Empirical Finance*, 11(4), 585-616.
- Javaira, Z., & Hassan, A. (2015). An examination of herding behavior in Pakistani stock market. *International Journal of Emerging Markets*, 10(3), 474-490.
- Jawadi, F., Jawadi, N., & Louhichi, W. (2014). Conventional and Islamic stock price performance: An empirical investigation. *International Economics*, 137, 73-87.
- Kim, K. A., & Nofsinger, J. R. (2005). Institutional Herding, Business Groups, and Economic Regimes: Evidence from Japan*. *The Journal of Business*, 78(1), 213-242.
- Klein, A. C. (2013). Time-variations in herding behavior: Evidence from a Markov switching SUR model. *Journal of International Financial Markets, Institutions and Money*, 26, 291-304.
- Kremer, S., & Nautz, D. (2013). Causes and consequences of short-term institutional herding. *Journal of Banking & Finance*, 37(5), 1676-1686.
- Lakonishok, J., Shleifer, A., & Vishny, R. W. (1992). *Do institutional investors destabilize stock prices? Evidence on herding and feedback trading*. Retrieved from
- Lean, H. H., & Parsva, P. (2012). Performance of Islamic indices in Malaysia FTSE market: Empirical evidence from CAPM. *Journal of Applied Sciences*, 12(12), 1274-1281.
- Lee, S., & Lee, K. (2015). Heterogeneous expectations leading to bubbles and crashes in asset markets: Tipping point, herding behavior and group effect in an agent-based model. *Journal of Open Innovation: Technology, Market, and Complexity*, 1(1), 11.
- Lin, A. Y., & Lin, Y.-N. (2014). Herding of institutional investors and margin traders on extreme market movements. *International Review of Economics & Finance*, 33(0), 186-198.
- Litimi, H., BenSaïda, A., & Bouraoui, O. (2016). Herding and excessive risk in the American stock market: A sectoral analysis. *Research in International Business and Finance*, 38, 6-21. doi:http://dx.doi.org/10.1016/j.ribaf.2016.03.008
- Loang, O. K. & Ahmad, Z. (2020). Social Factors and Herd Behavior in Developed Markets, Advanced Emerging Markets and Secondary Emerging Markets, *Journal of Contemporary Eastern Asia*, 19(1), 97-122.
- Lütje, T., & Menkhoff, L. (2003). Risk Management, Rational Herding and Institutional Investors: A Macro View. *University of Hannover, Discussion paper*(285).
- Messis, P., & Zapranis, A. (2014). Herding behaviour and volatility in the Athens Stock Exchange. *The Journal of Risk Finance*, 15(5), 572-590. doi:doi:10.1108/JRF-04-2014-0054
- Mobarek, A., & Mollah, S. (2013). *Cross-country analysis of herd behavior in Europe: Evidence from continental, nordic and the PIIGS countries*. Retrieved from
- Mobarek, A., Mollah, S., & Keasey, K. (2014). A cross-country analysis of herd behavior in Europe. *Journal of International Financial Markets, Institutions and Money*, 32, 107-127.
- Musse, O. S. H., & Echchabi, A. (2015). Islamic and conventional behavioral finance: A critical review of literature. *Journal of King Abdulaziz University: Islamic Economics*, 28(2), 249-266.
- Prosad, J. M., Kapoor, S., & Sengupta, J. (2012). An Examination of Herd Behavior: An Empirical Evidence from Indian Equity Market. *International Journal of Trade, Economics and Finance*, 3(2), 154.
- Sias, R. W. (2004). Institutional herding. *Review of financial studies*, 17(1), 165-206.
- Simões Vieira, E. F., & Valente Pereira, M. S. (2015). Herding behaviour and sentiment: Evidence in a small European market. *Revista de Contabilidade*, 18(1), 78-86.
- Spyrou, S. (2013). Herding in financial markets: a review of the literature. *Review of Behavioural Finance*, 5(2), 175-194.
- Tan, L., Chiang, T. C., Mason, J. R., & Nelling, E. (2008). Herding behavior in Chinese stock markets: An examination of A and B shares. *Pacific-Basin Finance Journal*, 16(1-2), 61-77.
- Wang, D. (2008). Herd behavior towards the market index: Evidence from 21 financial markets.
- Wen, Y. & Tikoo, S. (2020). Corporate strategy uniqueness, analyst herding, and financing constraints. *Strategic Organization*. Pp. 1-21.
- Yao, J., Ma, C., & He, W. P. (2014). Investor herding behaviour of Chinese stock market. *International Review of Economics & Finance*, 29(0), 12-29.
- Zhou, R. T., & Lai, R. N. (2009). Herding and information based trading. *Journal of Empirical Finance*, 16(3), 388-393.

THE CAUSES AND IMPLICATION FOR THE FAILURE AND DELAYED IN MUSLIM'S ESTATE DISTRIBUTION

Mohamad Ali Roshidi Ahmad

*Department of Accounting and Finance, Faculty of Management and Economics
Universiti Pendidikan Sultan Idris, Perak.*

ABSTRACT

Delays in estate distribution become a serious matter faced by majority of Muslims in claiming rights to Islamic estate in Malaysia. Hence, this will trigger an accumulation of unclaimed estate and frozen assets which cannot be distributed to deserving inheritors. Claims processes were very expensive and time-consuming over the years. The rising number of frozen assets has become unresolved issues facing Malaysia's Muslim community. Statistics by the authority reported that there are RM38 billion in land and properties, RM1.5 billion cash with the Unclaimed Monies Registrar, RM70 million with the Employee Providence Fund (EPF) and approximately one million land titles still in the name of the deceased. The distribution of the estate of the deceased is based upon the smooth administration of the estate. Aside from the beneficiaries have a major role in the administration from the personal representative, not as recipients of the estate of the deceased but as participants in the process of management of the estate. Nonetheless the simple laws regulating succession in Malaysia, problems relating to delay in the distribution of estate continue to rise, emerging from unresolved conflicts between the beneficiaries. Consequently there is more than 70 billion ringgit of unclaimed estate in Malaysia as reported by different sources, indicating the seriousness of this matter. This paper addresses the delay issues in the estate administration and its causes and consequences. The lack of know-how and the beneficiaries' attitude has been identified as the key factors leading to that problem. From the discussion, it show that a cohesive approach is needed to educate law beneficiaries and to change their approach attitude towards knowing their particular roles in the administration of the deceased's estate.

Keywords: estate distribution, estate planning, unclaimed estate. Muslim's estate

1.0 INTRODUCTION

Malaysia has two parallel law systems to regulate the matters of inheritance property, either by Civil law or Shariah law. Civil law as reflected in the federal statutes regulates non-Muslims while Islamic law or Shariah law governs Muslims. According to the Shariah law, the estate distribution is to follow the Faraid principles that determine the portions, scopes, and means of inheritance related to the deceased individual's estate, but it still allowed through an Islamic will to distribute up to one-third of the total value of an estate that already deducts the funeral expenses and debts. According to Civil law, the inheritance of the estate is subject to many laws and regulations. Both of Distribution Act 1958 and the Inheritance (Family Provision) Act 1971 define the estate and stipulate the conditions for inheritance (Jasni Sulong, 2011).

Besides this, the parties who are eligible to apply for estate distribution include the legal heirs, debtors, buyers, Amanah Raya Berhad (ARB), and Local Administrative Officer or head of community. There are three authorities where we can apply for estate distribution that includes ARB; Small Estate Section, Department of Director General of Lands and Mines (JKPTG); and High Courts, all of them manage the applications for estate distribution. ARB has the authority or power to administer and manage the movable estate that worth up to RM600,000, irrespective of that person is testate or intestate deceased. There are different processes based on the different value of the estate. ARB will issue an Order to the heirs when the value of the estate does not exceed RM50,000 in cash while for the value of the estate that exceeds RM50,000 but less than RM600,000, ARB will issue a Declaration. After this, the estates will then be pooled and distribute (Mohd Zamro Muda & Mohd Ridzuan Awang, 2006).

The intestate estates include small estates and non-small estates. A small estate is meant the estate of the deceased that comprising wholly or partly of immovable property that not exceeding RM2 million in total value which means without deduction of debts. The Land Office under the Small Estates (Distribution) Act 1955 (Act) is the authority with the power and jurisdiction to handle such small intestate matters or cases. The

land administrators have the power and jurisdiction to distribute the small estates. The Act provides the administration and procedure of the distribution of the small estate, and it is universal applicability so that it applies to Muslims and non-Muslims. Most Muslim's estates in this country are observed to belong to the category of a small estate.

On the other hand, there are non-small estates include in the intestate estates. The High Court is the authority that has the power and jurisdiction in the administration and distribution of the non-small estates. The non-small estate includes immovable properties, for example, land and building or a combination of both immovable and movable properties where the value of these properties are above RM2 million, and include also the movable properties, for example, the properties other than the land and building, where the value of these properties is more than RM600,000. The administration and distribution of the estate that value less than RM600,000 will go through the High Court, in the situation where there is a will left. Nevertheless, for the estate that value more than RM600,000 will also go through the High Court, but irrespective of whether or not there is a will left. The heirs have to provide two sureties for the estates that value is more than RM600,000 in the situation where there does not have a will left.

The ARB, Small Estate Section, High Court and Shariah Court were initially authorized to manage Islamic inheritance. The tasks of the Shariah Court include issue Faraid (distribution) certificate in order to determine who is entitled to inherit the estate of the deceased and certify the portion to which he or she is entitled; verification of hibah and wills, and to confirm the marital and child status. In addition, the administration and distribution of the estates of Muslims who pass away testate will go through the Shariah Court.

Under Malaysian law, all of the estates of the deceased will be frozen upon the person passes away until High Court grants the valid probate. When a deceased person who dies without leaving a will, his or her beneficiaries should take a number of steps to meet all of the legal requirements in order to benefit from the estate of the deceased, otherwise the estate of the deceased will remain frozen. The reasons may cause the unlocking of that deceased's frozen assets to be delayed, including selecting an administrator, identifying, locating and valuing the estate, and finding two sureties. Hence, there may be a delay in distributing the estates to the beneficiaries due to this unlocking process may take 2 to 8 years. If there are obstacles, for instance, family disputes, the beneficiaries disagree on the choice of the administrators, the administrator unable to provide sufficient sureties, then the process will be longer. Thus, in these complex situations, the process to unlock the frozen estate could take longer than 10 years, or worst of all, the estate may remain frozen forever. As a conclusion, it is important to have a plan about how the assets will be distributed, lest the asset is frozen.

It is often found that the estate of the deceased has been delayed before distribution, or in some cases delay until it is never distributed. However, regardless of whether a person died leaving a will (testate) or without a will (intestate), his estate could easily be unclaimed property, claimed but late, and distributed late, due to the causes that lead to failure and delay in the inheritance distribution. In Malaysia, there are issues faced by communities that related to a large number of unclaimed inheritance property and the number of frozen assets is increasing. Fazira Shafie, Wan Zahari Wan Yusoff and Syed Muhammad Dawilah Al-Edrus (2014) identify that "The values of unclaimed assets have increased from RM40 billion in 2009 to RM42 billion in 2011 and subsequently increased to RM60 billion in 2013". According to the records from the JKPTG through the Estate Distribution Division (BPP), Malaysians have left the estates that worth almost RM70 billion unclaimed since independence until now (Ekhwan Haque Fazlul Haque, 2020).

The above data displays severe delays in the processing of applications for estate allocation. This fact has also been proved that there is too much of the property, particularly those who have died a long time ago, but have not taken any action to give the rightful heir to have the ownership of the property. Furthermore, it is unfortunate, some beneficiaries are not aware of the existence of the property. The government took a variety of innovative preventive measures, such as to promote the communities to make will or hibah but appear to have failed and this can result from do not recognize all or the right reasons for this accumulation.

In addition, the distribution of Islamic inheritance after the death of a Muslim is an obligation that all Muslims cannot despise. Moreover, for Muslims, the practice of possessing wealth and assets without benefiting others is against the teachings of Islam. Ismael Saka Ismael (2016) also suggests that "Therefore delaying its distribution is religiously synonymous to disobedience or disregard of lawful command of Allah which amounts to transgressing the bounds of Allah". Therefore, every Muslim basically must weigh up the best way about how to manage his or her assets. However, although the concepts of property management have been recognized in Islam and served as a good purpose, there are still many Muslim communities in Malaysia who still lack interest and willingness, and neglect to plan for the distribution of wealth carefully, especially the

preparation and planning ahead for the inheritance distribution of property before they died. Many of them are not aware of the importance and necessity of planning in order to early distribution of property inheritance to the heirs. As a result, they are totally dependent on the Faraid that is the inheritance system of property division.

In Malaysia, although the administration of Islamic property is subject to Faraid rule, this rule has taken a toll on the well-being of communities to some extent. According to statistics released by the relevant authorities, it is estimated that about RM70 billion of estates failed to allocate to legal heirs. This situation shows most Muslims now be faced with some of the problems when managing the estate of the deceased and it would therefore lead to the accumulation of unclaimed estate and frozen assets and the end of the inability to distribute the estate to the legal heirs. This situation has aroused anxiety because of its negative effects on society and the country, and there are many factors that led to this failure. Hence, it is important to find out the causes or factors of delay and failure in the distribution of inheritance property that has left behind by the deceased.

In conclusion, the increasing trend in the number of unclaimed estates and frozen assets over the years has become a serious problem for the communities and it requires immediate solutions. This is because the increase in the unclaimed estates and frozen assets are the waste to the nation due to if the value of these estates or assets utilized for socio-economic development, for example, as an economic source, it is able to solve the problem of poverty in the community. Therefore, it needs to find out the determinant of causes for the failure and delay in the inheritance distribution.

2.0 OBJECTIVE

This paper concentrates on the determinant of causes that contribute to the failure and delay in the estate distribution. Hence, this paper explores some of the determinants of causes for the failure in the estate distribution, include lack of knowledge and understanding, lack of awareness, the weaknesses in system administration and distribution process, and the heirs or beneficiaries do not claim the properties or estate.

Besides this, this paper had also identified the factors of the delay in the estate distribution and found that there are several determinants of causes that contributed to this issue, there include the attitude of the beneficiaries, lack of guidelines to manage the estate, beneficiaries do not know about the existence of the property, and missing important documents.

In addition, this paper also acknowledges that the unclaimed money and asset be transferred, impact the relationship between the beneficiaries, causes tarnish the family's reputation and also the government legal system's reputation, and the worth of unclaimed assets will reach billions in the future, these all are the implications of failure and delay in the estate distribution.

3.0 CAUSES OF DELAY IN ESTATE DISTRIBUTION

The definition of delay refers to the issue in estate distribution that always happened in our society and it becomes a serious problem in our country that needed to be control by the authorities. Therefore, each of us must have the consciousness to make sure that this problem will not happen especially in our family. There are a lot of causes that can contributes to this issue such as lack of guidelines to manage the inheritance, beneficiaries don't know about the existence of property involved and missing important documents.

3.1 Lack of Guidelines to Manage the Estate

If a Muslim dies intestate (without a will or wasiat), his beneficiaries will need to take some steps before they can inherit from the estate. The process for an intestate estate can take one or two years longer depends on the situation. (Fazira Shafie, Wan Zahari Wan Yusoff & Syed Muhammad Dawilah el-Edrus, 2016). Under Malaysians law, the property is considered frozen when any transactions happened such as rent, sale, lease and charge if the estate is still registered under the deceased's name. Because of that, many beneficiaries assume that the process to claim their estate are complicated and a lot things they need to prepare to settle this inheritance. As there are still many in the community who do not understand how to settle the inheritance especially about the concepts and philosophies behind the distribution of the property. Proactive steps towards creating the understanding and awareness among the community need to be taken immediately. For instance, the authorities can create an awareness campaign and also promoting the learning of faraid knowledge. Besides that, all parties especially the State Religious Departments, prosecutors, JAKIM, JAWHAR and all community leaders need to work together to promote the awareness campaigns to the heirs about the importance of inheritance and distribution solutions in the most effective way. Therefore, awareness campaigns in this regard need to be intensified and continued from time to time. In order to ensure the sustainability of the field of faraid

knowledge, the authorities must further expand this learning especially in the center of higher learning, study in the surau or mosque and also can make it an optional subject at the secondary level.

Nowadays, the reality is that, not many are capable of mastering this knowledge because the methods that contains in this knowledge are difficult to grasp and understand especially at the mathematics part of faraid calculation. In addition, it is also recommended that this knowledge can be broadcast on mass media such as television and radio on a regular basis In order to provide in-depth knowledge to the entire community. Besides faraid, Muslim can also practice the application of Takharuj in the inheritance distributions. Takharuj means the heirs agree to exclude some of them from receiving the inheritance by accepting compensation payment taken from a tarikhah or the other properties. (Md Yazid Ahmad, Mohd Nasran Mohamad, Mohd Zamro Muda, Amir Husin Mohd Nor, Noor Lizza Mohamed Said, Ezad Azraai Jamsari and Badlihisam Mohd Nasir, 2018). Takharuj is one of the best ways to practice in the real estate distribution. This is because it would describes the existence of virtues in a family such as intolerance, understanding, family spirit and so on. Moreover, beneficiaries need to have more exposure about this concept because based on experience, some of the people do not know how to give their rights to others under the faraid law.

Some of the things that will hinder its implementation need to be dismissed such as nostalgic or sentimental values in order to realize this concept. This is because there are still existed certain people that do not want to give up the following inheritance even to their own relatives. This happened because it is a parental property that has sentimental values or events that need to be remembered while the parents are still alive. Meanwhile, there is also a misunderstanding of ownership of the property. This is because, there are some people who believe that inheritance must be taken as it has been determined by Allah Almighty through faraid law. If the law is blotted out, it is sinful. That is why there are some beneficiaries who want their name included in the land title even though it is only 100 square feet.

3.2 Beneficiaries Don't Know About Existence of Property

The causes of unclaimed property values increase each year due to many factors that has happened beyond their control. Among them, the heirs failed to detect it because they did not know there was any property that needed to be claimed and the heirs of the deceased (such as father, mother, grandparents, grandparents, ancestors) were not disposed of to the rightful heirs. In addition, the bureaucratic tendency in managing property causes the beneficiary to be lenient and refuses to take responsibility for ensuring that the deceased's estate is distributed. There are also cases where the inheritance of the property just ignored the land until the amount of land tax has accumulated after decades because of the unpaid and unsettled of that property. This would cause the beneficiary don't want to think on how to bear the cost and just let the heirloom assets remain 'frozen'. In addition, the lack of cooperation and co-operation between the heirs also caused them to place the burden of distributing the estate solely on the eldest child. However, most cases occur because the beneficiaries lack knowledge of inheritance and inheritance sciences.

There are about 20 percent of the land is still registered on behalf of the deceased (Nurshahruza Mat Zuki, 2019). This fact proves that there are still many among the heirs who have not settled the estate. Even more unfortunate for the heirs, because the compensation paid by the government will not be paid to them as long as the estate is not settled. Based on some examples of projects involving land acquisition by the government, it can be concluded that overall about one fifth of land ownership nationwide is owned by deceased persons, which is a relatively large number. Since the total number of all the titles in the whole country has exceeded six million, this means that more than one million titles nationwide are still owned by the dead. The property is considered frozen because any transactions such as lease, mortgage, sale, rent and so on cannot be carried out as long as the estate is still registered under the deceased's name. This things can cause worries to many people, including the family itself, the community and the nation in general. Besides that, there are also heirs who sell the estate through a deed of sale. This situation will cause some troubles for the buyer as the ownership of the land cannot be changed. Therefore, each of us is advised not to buy any land that is still registered in the name of the deceased even though it is cheaper than the market.

On behalf of the beneficiaries, it is advisable not to sell the undivided inheritance as there is a possibility that the income distribution may not be perfect and true due to ignorance in faraid knowledge. In terms of Islamic law, since most heirs do not have extensive knowledge of faraid law, they often slip by not giving the rights to the heirs who should be entitled to receive them. Unauthorized possession of property can cause a person to misappropriate the property and this act is strictly forbidden in religion. This is because, as long as the land has not been formally distributed, most of the heirs still do not know which of them is entitled to inherit and what portion that they will they inherit. The results of a study conducted on the application to divide the estate

in several districts in the state of Perak throughout 2007, found that only a small part of the heirs who tried to settle the estate immediately. They typically make a settlement within one year from the date of death of the property owner while the others take up to a few years to complete. Unfortunately, there are still a number of cases where death occurred in the 1950s, but the application for estate distribution was only made in 2010, after almost 83 years.

According to statistics in 2006, it is estimated that more than one million cases of estate claims in Malaysia with a value of RM38 billion are still outstanding due to not being managed by most heirs. Most of these cases involve almost 90 percent of them involving Muslim property. However, that number has risen to value which reached RM 40 billion in early 2007 and this amount involves more than one million cases of inheritance distribution still unresolved. Of that amount, 38 billion in real estate, RM 1.5 billion in cash, and RM 70 million from the Employees Provident Fund (EPF). 2010 also shows an estimated total of 40 billion properties owned by more than 500,000 heirs from among Muslims have yet to be liquidated (Rusnadewi Abdul Rashid and Noor Inayah Yaakub, 2010). This may happen because the heirs do not know about the existence of the estate or they deliberately let it freeze because no one wants to manage it.

Since too many estates are not managed and left alone, the heirs need to be more careful and aware of the affairs of their family's inheritance. Do not just place full responsibility on the eldest child because each child has their own task to help each other to solve this division of inheritance. They need to speed up the division of inheritance because when a person dies, automatically the property belonging to the deceased can be transferred to the heirs. To achieve that goal, it is the responsibility of all the heirs to understand the tasks that need to be done in the event of the death of the property owner which are to manage the corpse, immediately settle the debt of the deceased, fulfil his will if any and divide the estate by following the faraid law as best as possible.

3.3 Missing Important Documents

Losses of important documents to manage the division of the estate can also result to the delays in settlement of property. For example loss of death certificate, will, documents of sale and purchase agreement, marriage certificate and so on. The loss of these important documents would cause the beneficiaries to have difficulty in proving their claim. It is very unfortunate if the heirs are unable to remember the date of death of the deceased or are unable to remember the facts of their heirs. It is because, all of these facts will directly affect the process of allotment of property in determining the proportion of their respective shares and who the heirs are entitled to get it. The errors in providing facts of an inheritance case will result in incorrect division.

Applications must be made at the Small Estate Section, the Director General's Office of Federal Land and Mines (JKPTG) or the Land Office where the immovable property is located. If the deceased has several land titles in several districts or states, the heirs can choose to submit an application in one of the districts or states according to the convenience of the heirs. The first option of the application to be included in the district or state made will have an exclusive jurisdiction to enable the completion of all the deceased's estate located in various other districts or states. The beneficiary is encouraged to manage his own small estate application. However, the beneficiary still has the option to use the services of a lawyer or Amanah Raya Berhad.

When the number of heirs who will receive the inheritance become increases, the loss of important documents are among the difficulties that the heirs will face when resolving the process distribution of estate. There is a difficulty in having a discussion because the heirs live everywhere and this problem can result in the disagreement. As a result, the heirs will feel that the distribution of estate is something difficult and troublesome for them when in fact, this process is quite easy and fun because each of them will get their gift for free (Nasrul and Salim, 2018). Besides that, there are also among the heirs who are willing to give false testimony when confronted with a Shariah Court to obtain a faraid certificate or Small Estate Section Officer as the land administrator to divide the estate. This case is often happens because of the greed of the heirs who want to take full control of the estate without sharing it with their other relatives. It may also be due to dissatisfaction with something else such as ownership status, grants, wills and so on. Because of that, many various negative things have arisen due to this problem.

The interpretation given under section 3 (2) of the Small Property (Distribution) Act 1955 describes small estate as immovable property containing all or part of its immovable property located in any state and the total value not exceeding RM2 million at the date of application created. Without being bound by the stated value limit, any deceased property of non-Muslims containing a will under Will Act 1959 is no longer defined as a

small estate. It is considered a great legacy and is the responsibility of the High Court. However, the provision cannot be used for the death of a Muslim because it is contrary to the conditions and rules of will in Islam.

Therefore, the estate should be managed as best as possible and need to be hasten the distribution of the property to the rightful heirs. All the heirs should be responsible for managing and dividing the estate as best as they could. A good management in a distribution must take into account of the other aspects such as social, family and economic. Besides that, it also needs to be accompanied by praise worthy qualities such as caring, tolerant, cooperative with one another and also unselfish. Thus, it can trigger the unity of the family that has been left by the deceased, especially to the children of the deceased and the most important thing that it can strengthen the bond between siblings and other heirs.

3.4 Attitude of the Beneficiaries

The attitude of ignorance of the beneficiaries is one of the reasons why there is a delay in estate distribution. A negative personal attitude portrayed by a beneficiary will interrupt the smooth process of estate distribution. The attitude of taking for granted, take it easy attitude, laziness, greediness, obsession over property are among example of negative attitude which causes delay in estate distribution.

Our community does not consider this issue as an important matter. According to Fazira Shafie, Wan Yusoff Zahari and Syed Muhammad Dawillah (2016), our community assume that the duty to settle asset is a trivial task. Sometimes, they think the duties should be done by the eldest son only which is actually very wrong perception. The tendency to rely on certain people like older siblings to manage the estate also exacerbates this problem. On the other hand, they also assume that we must not speed up the process the distribution in order to respect the deceased. Our community is generally thinks that asset distribution is a sensitive topic to be discussed (Fazira et al, 2016). Such situation indirectly restricts the well aware heirs to perform their duty which are unfortunately being labeled as greedy and being obsessed with the deceased's property. Thus, resulting disputes and conflict among the other beneficiaries.

The mentality towards property management in this country is still low. (Nadia Hamid, 2017). Moreover, lack of cooperation and agreement between the heirs led them to place the burden of distributing the property on the eldest heirs only to settle the inheritance. Mohd Khairy Kamaludin, Azwan Abdullah, Mohd Asrul Ibrahim and Siti Fariha Muhamad (2015) stated the heirs failed to cooperate and disputed the inheritance as there was a record in land office that the ownership was unable to transfer due to difficult to obtain permission, acceptance or agreement from other heirs. This is because of the conflict arising between the heirs to determine who will be the next owner. So, the claim of inheritance will be deferred until all the heirs have agreed and tolerate each other. This definitely will delay the process of inheritance distribution.

Next, attitude of taking things granted will also cause the delay in distributing inheritance. This can be seen in some cases like late application for administration to administrative bodies. This is due to beneficiaries have carefree attitude. Mohd Khairy Kamaludin et al (2017) stated that under the law, the application for administration should be made not less than six months after the deceased passed away. Failure to do so will not be penalized but they need to provide proper reasons with explanation. However, this attitude is still considered not a good manner and this caused delay in asset distribution.

On the other hand greediness also part of heir's attitude which can late the process of inheritance distribution. The greedy nature of the heirs who want to demolish all assets and want more could delay the process for many years. The issue of disputes due to greediness between the heirs has been widely reported in the newspapers because of dissatisfaction with the share of inheritance. For example, fighting due to who is qualified for small land and car which cannot be divided into portions accordance to faraid law. Another example is they choose not to appear during the trial for inheritance distribution and also deliberately omit important documents related to deceased inheritance assets.

Other than that, the attitude of owner of the asset also might impact the inheritance process after he passed away. He should manage the process of will, hibah and other when he still alive so the process of distribution can be done smoothly later. The deceased must aware the importance of managing asset since early.

4.0 IMPLICATIONS OF THE DELAY AND FAILURE

Many take it easy and look down on the process of managing asset and properties when the deceased is still alive or death. They think this is not a big issue. Our community refused to understand that asset management

could be riskier and complicated if we do not planned in advance. Nor Afzan Yusof (2019) found that in his campaign of real estate planning there are many take it easy and they do not understand that planning early will ease the heirs from go through unnecessary processes of claiming assets. He also added that some of them found that their grandparents passed away over 10 years. So the process of claiming will consume more time. Failure or delay in inheritance distribution could lead to many implications. The implications are serious because it includes the rights of beneficiaries and also creditors. This is because the process of distribution only can be done after many procedures like make application for administration and others.

The first implication is unclaimed money and asset. According to Mohd Khairy Kamaludin et al (2017) the deceased frozen account for more than seven years will be transferred to registrar of unclaimed money under the Unclaimed Money Act 1965. So the beneficiary can no longer deal with the former bank because the money has been transferred. This process will consume more time than dealing with bank. In this phase, the beneficiaries might have to go through more complicated processes compare to claiming the money directly from the bank.

In addition, incomplete estate distribution will also impact the relationship between the beneficiaries. The longer the process the longer they feel tension and stress. This will also trigger disputes and conflicts among each other. They will also start to blame each other for the delay. If their relationship get sour, the process of claiming and distributing will be worse. For example, they will simply not appear during the meeting or discussion of asset distribution. Beside they also can simply lost the important documents. All this will lead delay or fail the process of distribution. In short, this will also cause broken relationship among family members.

Finally, delay and failure does not only affect beneficiaries but also causes tarnish the family's reputation and also government legal system's reputation. Nowadays social media will spread all the good and also bad news faster than anything. News about family disputes due to asset distribute will create bad impression in the society. It also make us to look down on the legal systems because the system could not solve the problems immediately. Apart from that they also need to make payment to those they owe money. For example, if the deceased owe RM3000 from someone they have to settle using the asset of the deceased it as soon as possible. In this matter, creditors are being affected too. So the beneficiaries should consider in general and stop being selfish.

Moreover, the worth of unclaimed assets will reach billions in future. Based on Arfa Yunus, Batrice Jay and Fernando Fong (2017), Malaysia has RM5.96 billion of unclaimed money. This is due to the all the causes we have discussed above. This is not including the unclaimed assets. The worth will keep increase or even decrease in future. However, when the assets are left unclaimed for many years the accumulated assets will be charged for tax. So that the heirs should be aware and concern about their rights so that they will never lose their property that can be utilized and at the same time can serve as the catalyst for economy.

In the aspect of economy, the land and the properties that are left unclaimed can generate more income to our economy. For example, in Muar over 30 hectares of land are not claimed by the legal heirs. Neglect and delaying the division process has resulted in majority of the agricultural land is now deserted and has been the wildlife habitat (Rusnadewi Rashid and Noor Inayah Yakoob, 2010). In addition, high commercial value lands are also cannot be developed due to this problem. Most of the village are still lagging behind in terms of development because or large overlapping unclaimed. There are numbers of problem may arise and our community might affect economically due to unresolved inheritance process. For example, efforts for development by individuals who want to made privately or individually will cause some difficulties including failure to get financing from a bank or financial institution. This follows from the failure to obtain ownership because it is still registered under the name of the deceased. As a consequence the land also cannot be lent to the bank to obtain money or sold to others. So it will left undeveloped and we cannot generate any income through the land.

In short, it is important for the deceased to make plan from the beginning to avoid such implications. This also causes the beneficiaries to suffer to go through a lot of complicated process. In the end this leads the beneficiaries to unutilized the inheritance. By understanding and aware of the implication due to failure and delay of inheritance distribution the beneficiaries should follow all the rules and procedure to make the process smooth.

5.0 CONCLUSION

The causes for the delay in estate distribution are lack of guidelines to manage the estate, beneficiaries do not know about existence of property, missing important documents, and attitude of the beneficiaries. The implications for the failure and delay in estate distribution are unclaimed money and asset, incomplete estate distribution will also impact the relationship between the beneficiaries, causes tarnish the family's reputation and also government legal system's reputation, the worth of unclaimed assets will reach billions in future, and the land and the properties that are left unclaimed can generate more income to economy.

In Malaysia, there is various process in the estate distribution and administration of the estate so it take long period of settlement. This is because the estate distribution involvement of different parties, different procedures and it is a lengthy process. The problem in estate planning is the delay in estate distribution can detriment to all. Hence, the beneficiaries should avoid the matters that could causes for delay in estate distribution.

After knowing causes for the failure and delay in estate distribution, people should be aware of the crucial knowledge regarding the estate distribution. They can get the information through internet by using smartphones and electronic devices or ask professional. Beneficiaries can understand how the estate administration is being carried out rather than waiting for the estate distribution because they have the fundamental knowledge of actual rights and duties in estate administration.

The beneficiaries must have emotional maturity so they can control the negative feelings and prevent unnecessary disputes that destroy the smooth process in estate distribution. Hence, the beneficiaries can contribute a quick process in the estate distribution. If it is taken longer time to liquidate and distribute the property to the legal heirs, there will have great losses suffered by beneficiaries. When the property become frozen property or unclaimed asset, the property will failed to produce economic benefits to the beneficiaries.

The delay of distribution inheritance properties such as the immovable property will cause the problem of develop the land. The failure of estate distribution has negative effects such as legal perspective and economy. There have several factors affect period to liquidate the assets that can be the efficiency of the institutions involved in inheritance administration such as Amanah Raya Berhad (ARB), Small Estate Distribution Section, Shariah Court and the High Court.

There is important to proper and early manage estate regarding wealth that will be left. Because the deceased's wealth had to be stopped after the death and can be used after distribution of estate to legal heirs is completed. For Muslim, the effective tool in estate administration such as Hibah and Wasiat can be used to distribute the inheritance properties wisely after the death.

REFERENCES

- Arfan, Y., Jay, B. & Fong, F. (2017). Malaysians have RM5.96 Billion in Unclaimed Money. News Straits Times. Retrieved from <https://www.nst.com.my/news/nation/2017/11/303548/malaysians-have-rm596-billion-unclaimed-money>
- Bibi Nur Adila Zulkaffi & Md Yazid Ahmad (2016). Kekangan dan Penyelesaian Kelewatan Pengurusan Aset Pusaka Tak Alih Orang Islam di Malaysia. Retrieved from: <http://journalarticle.ukm.my/10228/1/16912-47683-1-SM.pdf>
- Ekhwan Haque Fazlul Haque (2020). Harta RM70 bilion tergantung. *Harian Metro*. Retrieved from <https://www.hmetro.com.my/utama/2020/01/534382/harta-rm70-bilion-tergantung>
- Fatin Afiqah Md Azmi & Mohammad Tahir Sabit Mohammad. (2011). The causes of unclaimed, late claimed or distributed estates of deceased Muslims in Malaysia. *International Conference on Sociality and Economics Development*, 10, 440 - 444. Retrieved from <https://www.yumpu.com/en/document/read/23031893/the-causes-of-unclaimed-late-claimed-or-distributed-ipedr>
- Fazira Shafie & Wan Yusoff Wan Zahari. (2016). Factors of Failure and Delay in Islamic Inheritance Distribution in Malaysia. Retrieved from https://www.researchgate.net/publication/319743194_Factors_of_Failure_and_Delay_in_Islamic_Inheritance_Distribution_in_Malaysia
- Fazira Shafie, Wan Zahari Wan Yusoff & Syed Muhammad Dawilah Al-Edrus (2014). Islamic real estate management: Review on issues and challenges in managing inheritance property in Malaysia. *International Real Estate Research Symposium 2014 7th IREERS, at Kuala Lumpur*, 1-15. Retrieved from https://www.researchgate.net/publication/263083792_ISLAMIC_REAL_ESTATE_MANAGEMENTREVIEW_ON_ISSUES_AND_CHALLENGES_IN_MANAGING_INHERITANCE_PROPERTY_IN_MALAYSIA
- Ismael Saka Ismael (2016). Consequences of delaying distribution of estate in Islamic law of inheritance: The Nigerian experience. *Shariah Journal*, 24(2), 303 - 320. Retrieved from <https://ejournal.um.edu.my/index.php/JS/article/view/4349>
- Jasni Sulong (2011). *Pembaharuan Undang-undang Pentadbiran Pusaka Islam*. Pulau Pinang: Penerbit Universiti Sains Malaysia.
- Kamarudin, M. K., Abdullah, M., Ibrahim, M. A. & Muhamad, S. F. (2015). Pembahagian Pusaka Di Kalangan Waris: Pendekatan Ahp. Retrieved from https://www.researchgate.net/publication/277022224_PEMBAHAGIAN_PUSAKA_DI_KALANGAN_WARIS_PENDEKATAN_N_AH
- Md Yazid Ahmad, Mohd Nasran Mohamad, Mohd Zamro Muda, Amir Husin Mohd Nor, Noor Lizza Mohamed Said, Ezad Azraai Jamsari and Badlihisam Mohd Nasir (2018). Takharuj as an Effective Solution to the Inheritance Problems of Muslims. Retrieved from <http://docsdrive.com/pdfs/medwelljournals/sscience/2018/1094-1100.pdf>
- Mohd Arafat Jaafar (2017). Harta yang Tidak Dituntut dalam Islam dan Undang-Undang di Malaysia. Retrieved from: <http://eprints.utm.my/id/eprint/78760/1/MohdArafatJaafarMFTI2017.pdf>
- Mohd Hafizee Mohd Arop (2019). Rancang awal pewarisan hartanah. Retrieved from: <https://www.hmetro.com.my/mutakhir/2019/11/517806/rancang-awal-pewarisan-hartanah>
- Mohd Zaky Zainuddin (2020). AWARIS Sasar Urus Aset Amanah, Wasiat Lebih RM5.5b. Retrieved from: <https://www.bharian.com.my/bisnes/korporat/2020/03/664390/awaris-sasar-urus-aset-amanah-wasiat-lebih-rm55b>
- Mohd Zamro Muda & Mohd Ridzuan Awang (2006). *Undang-undang Pusaka Islam: Pelaksanaan Di Malaysia*. Bangi: Universiti Kebangsaan Malaysia.
- Nadia Hamid (2017). Kerenah Birokrasi, Kurang Ilmu Punca Pusaka RM60b Terbiar. Berita Harian Online. Retrieved from <https://www.bharian.com.my/rencana/agama/2017/07/292113/kerenah-birokrasi-kurang-ilmu-punca-pusaka-rm60b-terbiar>
- Nasrul, M. A. D., & Salim, W. N. M. (2018). Administration of estates in Malaysia: Determinant of factors behind the delay in the distribution of the deceased's asset. *Journal of Nusantara Studies (JONUS)*, 3(1), 75 - 86.
- Nor Afzan Yusof (2019). Usah Ambil mudah Persoalan Wasiat, Pengurusan Harta Selepas Mati. Berita Harian Online. Retrieved from <https://www.bharian.com.my/rencana/agama/2019/06/576016/usah-ambil-mudah-persoalan-wasiat-pengurusan-harta-selepas-mati>
- Nurshahzura Mat Zuki (2019). Hartanah Pusaka Sukar diwarisi Pemilik Harta Gagal Rancang Harta Ketika Hidup. Retrieved from: <https://www.sinarharian.com.my/article/8951/BISNES/Hartanah-pusaka>
- Pembahagian Harta Pusaka. Diperoleh daripada <https://www.jkptg.gov.my/my/panduan/sop/pembahagian-harta-pusaka>
- Pentadbiran Harta Pusaka. Diperoleh daripada <http://www.jbg.gov.my/images/doc/risalah/pentadbiran-harta-pusaka.pdf>
- Prosedur Permohonan Pusaka Kecil. Diperoleh daripada <https://www.malaysia.gov.my/portal/content/30333?language=my>
- Rosman, Ab Razak. (2018), Factors Inhibiting Islamic Will Adoption: Focus on Muslim Community, Addison-Wesley, and Reading, MA. Retrieved from https://www.researchgate.net/publication/285991526_Selection_Factor_of_E-Faraid_in_Segamat_What_does_Muslim_Say
- Rusnadewi Abdul Rashid & Noor Inayah Yaakub (2010). Masalah Kegagalan dan Kelewatan Pengagihan Harta Pusaka di Malaysia. Retrieved from: <file:///C:/Users/user/Downloads/8-Article%20Text-18-1-10-20150903.pdf>
- Shafie, F., Yusoff, W. Z. W., & El-Edrus, S. M. D. (2016). Factors of failure and delay in Islamic inheritance distribution in Malaysia. In 8th International Real Estate Research Symposium (IREERS).
- Shamsul Kamal Amarudin (2020). Buat Perancangan Elak Isu Waris Berlapis. Retrieved from: <https://www.bharian.com.my/berita/nasional/2019/11/629092/buat-perancangan-elak-isu-waris-berlapis>

MEKANISME BANTUAN ZAKAT DALAM MEMBANGUNKAN PENDIDIKAN ANAK-ANAK ASNAF DI KEDAH

Azizah Othman^{*a}, Syarifah Md Yusof^b, Raziah Md Tahir^a & Norashidah Hashim^b

^aIslamic Business School, Universiti Utara Malaysia, MALAYSIA

^bSchool of Business Management, Universiti Utara Malaysia, MALAYSIA

Abstrak

Pendidikan dalam Islam sangat penting kerana ayat al-Quran pertama kali diturunkan kepada Nabi Muhammad SAW adalah surah al-'Alaq ayat satu hingga lima. Proses untuk mencapai pendidikan yang baik memerlukan dana kewangan yang tinggi dan tidak semua orang yang mampu, terutamanya golongan asnaf fakir dan miskin. Kemiskinan harta yang digabungkan dengan kemiskinan jiwa sangat berbahaya kerana dapat mendorong individu tersebut cepat putus asa dan hidup dalam kekecewaan. Zakat sebagai instrumen yang menjamin keadilan sosial dalam masyarakat dapat berperanan aktif dan efisien untuk membantu keluarga miskin. Tidak adil membiarkan orang miskin terus hidup dalam kemiskinan harta benda, kerana sumbangan kepada institusi kewangan Islam dapat memberi harapan kepada asnaf untuk mengubah status kehidupan, terutama melalui bantuan pendidikan. Kertas kerja ini bertujuan untuk mengenalpasti mekanisme bantuan oleh Lembaga Zakat Negeri Kedah (LZNK) dalam membantu pelajar-pelajar asnaf fakir, miskin dan *fi-sabilillah*. Metodologi kualitatif dilakukan dengan menemu bual informan yang berkaitan dengan isu yang dikaji. LZNK berperanan proaktif dalam membantu asnaf melalui pelbagai bantuan pendidikan. Sebilangan besar agihan tahunan zakat disalurkan kepada bantuan pendidikan melalui pelbagai program yang dijalankan oleh LZNK. Bantuan LZNK untuk pendidikan bermula dari sekolah menengah hingga tahap pendidikan tinggi iaitu pengajian doktor falsafah. Kajian ini mendapati bahawa ramai anak-anak asnaf yang mendapat peluang belajar dengan bantuan zakat pendidikan dan mereka juga memerlukan bantuan lain seperti komputer riba, buku-buku rujukan dan makanan yang sihat. Kajian juga mencadangkan agar LZNK perlu mengemas kini profil pendidikan asnaf yang berjaya dan memperbaiki kaedah pemantauan penerima. Mekanisme agihan bantuan pelajar luar negara juga perlu dipertingkatkan pengurusannya serta LZNK juga dicadangkan agar dapat meluaskan bantuan pendidikan kepada anak-anak asnaf di sekolah rendah.

Kata kunci: Zakat Pendidikan, Lembaga Zakat Negeri Kedah (LZNK), Asnaf fakir dan miskin, Fisabilillah

PENGENALAN

Kepentingan ilmu pengetahuan dan pendidikan yang sempurna serta sama rata kepada semua lapisan masyarakat sangat ditekankan di dalam Islam. Di dalam al-Quran terdapat banyak ayat yang menekankan kepentingan aspek pendidikan dalam pembinaan tamadun manusia. Selain itu, Rasulullah SAW juga amat mementingkan pendidikan, baginda telah mengadakan kelas mempelajari Islam di rumah Arqam bin Abi al-Arqam (Hamim Hafiddin, 2015) serta baginda meletakkan syarat bagi tawanan Badar yang hendak dilepaskan hendaklah mengajjar anak-anak orang Islam mengenal huruf, membaca dan menulis (Hamizul Abdul Hamid (2017).

Menurut Haron Daud (1995), Za'aba menyatakan ilmu dan pendidikan mempunyai kaitan dengan kemiskinan jiwa. Kemiskinan jiwa ini boleh merosakkan kehidupan manusia, kerana manusia akan terdedah melakukan hal-hal yang dilarang oleh agama dan undang-undang negara. Disamping itu, masyarakat yang miskin ilmu dan pendidikan ini juga mempunyai hubungan dengan kemiskinan harta. Masyarakat yang keadaan ekonominya tidak stabil atau relatifnya miskin tidak mampu memberikan pendidikan yang sempurna kepada anak-anak mereka dan tidak berupaya membina kehidupan yang lebih baik. Hal ini bertambah parah apabila kemiskinan harta ditambah dengan kemiskinan jiwa akan mendorong individu berkenaan untuk menggadaikan maruah diri dan akidah demi sesuap nasi (Hamizul Abdul Hamid, 2017).

Di sinilah pendidikan memainkan peranan yang sangat penting dalam pembentukan tamadun manusia dan pembangunan sosial negara. Jika hal berkaitan pendidikan dan ilmu pengetahuan diabaikan, ia akan memberi impak negatif kepada pembangunan sesebuah negara. Zakat juga dianggap sebagai indikator untuk menentukan kesejahteraan rakyat. Ini kerana formula terbaik dalam memastikan ekonomi negara mapan adalah dengan memastikan ekonomi negara meningkat dan ini secara langsung memberi kesan dalam peningkatan jumlah zakat. Melalui pelaksanaan zakat di Malaysia, rakyat yang berada di dalam kategori penerima zakat dapat dibantu dengan sebaiknya.

Oleh itu, institusi zakat sebagai institusi kewangan Islam perlu terus giat memainkan peranan dalam menyalurkan bantuan dana zakat pendidikan kepada golongan asnaf di Malaysia dan memastikan tiada golongan asnaf fakir dan miskin yang tercicir dalam mendapatkan peluang pendidikan pada semua peringkat. Ini kerana bantuan pendidikan amat penting dalam membantu asnaf fakir dan miskin di dalam mengubah kehidupan dan mengeluarkan golongan ini daripada kelompok kemiskinan dan berjaya seperti orang lain.

2.0 METODOLOGI KAJIAN

Metodologi kajian yang digunakan oleh penyelidik dalam menjalankan kajian ini adalah dengan menggunakan pendekatan kualitatif yang melibatkan kajian lapangan berbentuk temu bual separa berstruktur dan kaedah analisis dokumen. Kaedah penyelidikan kualitatif membolehkan penerokaan yang mendalam untuk mendapatkan dapatan yang komprehensif bagi mencapai objektif kajian (Creswell, 2013). Data dan maklumat yang diperolehi daripada temu bual informan dan dokumen-dokumen berkaitan daripada laman portal rasmi LZNK dan laporan tahunan yang dianalisis secara analisis kandungan bersesuaian dengan objektif kertas kerja ini. Informan temu bual terdiri daripada pihak pengurusan Unit Pendidikan di LZNK.

3.0 BANTUAN ZAKAT PENDIDIKAN LEMBAGA ZAKAT NEGERI KEDAH

LZNK telah memainkan peranan yang proaktif dalam membantu asnaf melalui pelbagai bantuan pendidikan. Jumlah agihan yang besar telah disalurkan kepada pembangunan pendidikan melalui pelbagai program. Antara bantuan yang diberikan ialah Bantuan Yuran Peperiksaan Penuntut Miskin Sekolah Agama Nidzomi, Bantuan Persekolahan Bulanan, biasiswa, dermasiswa dan bantuan-bantuan lain.

Tiga golongan asnaf yang terlibat dalam bantuan pendidikan LZNK ialah asnaf fakir, asnaf miskin dan asnaf *fi-sabilillah*. Tafsiran asnaf tersebut adalah berdasarkan Enakmen Agama Islam Negeri Kedah seperti berikut:

Asnaf fakir

Adalah orang tiada harta pendapatan yang mencukupi untuknya dan keperluannya. Tidak mempunyai keluarga untuk mencukupkan nafkahnya seperti makanan, pakaian dan tempat tinggal. Contohnya ia memerlukan RM10 sehari tetapi hanya mampu RM3 sahaja.

Asnaf Miskin

Mempunyai kemampuan usaha untuk mendapatkan keperluan hidupnya tetapi tidak mencukupi sepenuhnya. Sebagai contoh seseorang miskin memerlukan RM10 tetapi hanya memperolehi RM8.

Asnaf Fi-Sabilillah

Fi-sabilillah ialah perjuangan, usaha dan aktiviti yang bertujuan untuk menegakkan dan mempertahankan agama Allah.

4.0 MEKANISME BANTUAN PENDIDIKAN LZNK

Bantuan LZNK untuk pendidikan bermula dari sekolah menengah hingga ke tahap pendidikan yang lebih tinggi seperti pengajian doktor falsafah. Daripada analisis terhadap data temubual serta dokumen yang berkaitan, terdapat beberapa bentuk bantuan pendidikan yang diberikan oleh LZNK kepada institusi dan individu yang layak untuk menerima bantuan tersebut.

Jadual 1.1: Bantuan Pendidikan oleh LZNK Tahun 2019

No.	Jenis Bantuan	Jumlah Peruntukan
1	Sekolah Agama Nizomi	2,500.000.00
2	Maahad Addini	4,300.000.00
3	Binaan masjid, surau & sekolah agama	3,000.000.00
4	Dermasiswa (IPT tempatan)	17,700.000.00
5	Dermasiswa awal (IPT luar negara)	420.000.00
6	Dermasiswa (Mesir)	3,040.000.00
7	Dermasiswa (Jordan)	950.000.00
8	Dermasiswa (Yaman)	50.000.00
9	Dermasiswa (Indonesia)	560.000.00
10	Dermasiswa (Maghribi)	70.000.00
11	Biasiswa pelajar (IPTA)	2,392.500.00
12	Biasiswa pelajar perubatan (Mesir)	2,745.000.00
13	Biasiswa pelajar (UNISHAM)	2,400.000.00
14	Biasiswa pelajar cemerlang bulanan	972.000.00
15	Biasiswa mursyid	100.000.00
16	Program pembangunan Pendidikan	700.000.00
17	Bantuan tambang penuntut yang lulus & tamat pengajian	180.000.00
18	Pondok moden zakat	2,200.000.00
19	Bantuan institusi pondok	1,843.000.00
20	Penajaan ruwaq jawi	300.000.00

Sumber: Temubual Pegawai LZNK (2019)

a) Bantuan Sekaligus

Merupakan peruntukan terbesar wang zakat melibatkan lebih RM18 juta iaitu bantuan awal untuk kemasukan universiti dalam dan luar negara. Ini kerana ramai pelajar dari kalangan anak-anak asnaf yang tidak mampu untuk membayar yuran awal dan pendaftaran. Pelajar perlu memohon pada tahun pertama pengajian dan semua layak memohon dibawah asnaf fi sabilillah.

“ Untuk sijil kita bagi RM600, Diploma RM800, Ijazah RM1000. Master dan PhD juga diberi RM1000. IPT luar negara kita bagi RM1200”
(Informan A, 2019)

b) Biasiswa

Biasiswa turut diberikan kepada pelajar IPTS dan IPTA yang berkelayakan untuk menyambung pelajaran mereka diperingkat yang lebih tinggi. Kebanyakan pelajar Unishams ditawarkan biasiswa untuk membiayai yuran pengajian dan sara hidup mereka. Pelajar-pelajar dari IPTA lain dan bukan bidang agama juga ditawarkan biasiswa sekiranya layak dan lulus temuduga yang dijalankan oleh LZNK.

Yang ini, program ijazah, setakat ni kita bukak kepada semua kos. Tapi dalaman kita tapis jugak la, program yang tari menari tu kita nak bayar duit zakat.. part dalaman ni kita tapis la. Yang ini kita bagi RM7500 setahun. RM3750 untuk satu semester. Yang ini, sepanjang pengajian lah. Kalau dia mengaji 3 tahun, 3 tahun lah. Kalau ngaji 4 tahun, 4 tahun lah. Sebab dia bergantung kepada universiti jugak kan. (Informan A, 2019)

c) Sekolah Agama Rakyat

LZNK turut membantu sekolah agama rakyat untuk menjalankan operasi pembangunan sekolah mereka. Sebanyak 27 buah sekolah menengah Agama dan sekolah rendah Agama telah dibantu oleh LZNK di seluruh negeri Kedah. Antaranya SMA Islah, Pendang, Maahad Tahfiz al-Barakah Tikam Batu, SMA Daris Sungai Petani dan lain-lain. Bentuk bantuan perkapita kepada sekolah mengikut bilangan pelajar dan guru sekolah tersebut. Aghian bantuan zakat boleh digunakan untuk membaik pulih bangunan atau pun membantu pelajar-pelajar dan guru yang memerlukan bantuan. Bantuan yang diberikan adalah RM200 satu kepala pelajar, guru dan kakitangan sekolah. Bantuan turut diberikan kepada sekolah pondok tradisional yang berdaftar dengan Majlis Agama Islam Kedah (MAIK) dan mewakaf tanah tersebut.

“Yayasan Khairiah, Melele. Senarai tu kita boleh bagi, kita akan bagi. Yang ini kita bagi pada pengurusan. Pengurusan tu maksud dia di sini, bila kita bagi satu amaun, berdasarkan kepada bilangan pelajar dan guru tu, dia boleh guna untuk baik pulih bangunan, ataupun membantu asnaf-asnaf kat sekolah tu. Boleh. Takdak masalah.” (Informan A, 2019)

d) Pembangunan Pendidikan

LZNK turut giat menjalankan beberapa program pendidikan yang dilihat mampu menyuntik kesedaran dan memberikan manfaat kepada golongan asnaf tersebut. Antara aktiviti dan program yang giat dijalankan adalah program motivasi dan kemahiran pelajar, akademi pendakwah muda, akademi kepimpinan zakat Kedah dan persiapan menghadapi alamkerjaya.

Selain daripada itu, LZNK juga telah memberi bantuan projek khas pembangunan pendidikan Pulau Tuba dengan kerjasama Yayasan Pelajaran Maray yang dijalankan di SMK Langkawi, Pulau Tuba. LZNK turut memberi bantuan projek khas CEO@School yang bertujuan melahirkan CEO Muslim professional yang pakar dalam bidang perakaunan yang melibatkan kerjasama Pusat Pengajian Perakaunan Tunku Intan Syafinas (TISSA), Universiti Utara Malaysia (UUM).

e) Sekolah Zakat

Pondok Moden Zakat Kedah (PMZK) merupakan Pondok Moden yang pertama yang ditubuhkan di Negeri Kedah. Penubuhan Pondok Moden Zakat Kedah adalah daripada cetusan idea Syeikh Zakaria bin Othman iaitu Ketua Pegawai Eksekutif LZNK. Beliau memperoleh idea ini setelah mengadakan siri jelajah di beberapa buah pondok dan Institusi Pendidikan di Malaysia. Cetusan idea ini disambut baik oleh Sahibus Samahah Dato’ Mufti Kedah, Syeikh Fadhil Awang dan beliau turut bersama-sama berusaha menjayakan hasrat penubuhan PMZK. Tujuan penubuhan Pondok Moden ini adalah untuk melahirkan Ulama’ yang kompeten dalam bidang ilmu agama dan ilmu duniawi yang sentiasa bersedia untuk menjadi barisan kepimpinan dimasa akan datang. Manakala Maahad Dini Sultan Abdul Halim pula terbahagi kepada dua buah sekolah iaitu Maahad Dini Sultan Abdul Halim (Alor Setar) yang terletak di Jalan Suka Menanti, Alor Setar dan Maahad Dini Sultan Abdul Halim (Sik) pula terletak di Kampung Belantik, Sik. Misi Maahad Dini pula ialah melaksanakan sistem pendidikan yang terbaik dari sudut akademik dan dini bagi melahirkan modal insan yang menguasai pelbagai disiplin ilmu ke arah memenuhi aspirasi negara.

f) Dermasiswa

Bantuan khusus untuk pelajar-pelajar yang belajar diluar negara seperti Mesir, Jordan dan Indonesia. Pelajar bidang agama dan perubatan sahaja yang dipilih untuk menerima dermasiswa ini. Pelajar-pelajar yang berjaya akan dibiayai pengajian mereka sehingga tamat pengajian. Mulai 2017, bantuan diberikan mengikut kelulusan pengajian pelajar iaitu Mumtaz RM10000, Jayyid Jiddan RM8000, Jayyid RM6000 dan Maqbul RM4000. Bagi pelajar di Jordan, lulusan Mumtaz akan mendapat RM12000, Jayyid Jiddan RM10000, Jayyid RM8000 dan Maqbul RM6000. Di Indonesia, bantuan mengambil kira Gred A, B, C. Gred A akan menerima RM5000, Gred B akan menerima RM3000 - RM4000, Gred C akan menerima RM2000.

“Yang seterusnya, yang dermasiswa luar negara tu, yang Mesir, Jordan, Indonesia, yang ini dia ada dia punya khusus, untuk dini sahaja. Setakat ni untuk dini sahaja, dan juga untuk perubatan. Amaun, kalau tahun sebelum-sebelum ni, pelaksanaan kita, kita bagi sama ja. Untuk Mesir ni kita bagi semua RM6000 setahun. Kemudian diubah mengikut kelulusan pengajian kerana ramai yang mendapat keputusan yang kurang memuaskan.”
(Informan A, 2019)



Rajah 1.1: Bentuk-bentuk bantuan Pendidikan oleh LZNK

5.0 KESIMPULAN

Lembaga Zakat Negeri Kedah telah menyalurkan agihan yang besar terhadap bidang pendidikan sama ada kepada institusi-institusi pendidikan dan sumbangan terhadap individu. Namun penyaluran bantuan zakat kepada individu lebih besar jika dibandingkan dengan institusi yang terlibat. Ini membuktikan bahawa peranan zakat sangat besar dan signifikan terutama dalam bidang pengajian Islam kerana melahirkan lebih ramai cendekiawan Islam. Usaha ini akan membuatkan prestasi LZNK semakin penting dan semakin diyakini oleh masyarakat dari aspek tadbir urus korporat seterusnya dapat meningkatkan lagi kutipan dan agihan zakat di masa akan datang.

Kebanyakan pelajar yang menerima bantuan zakat dapat menjalani proses pembelajaran dengan selesa kerana dapat tinggal di asrama dan tidak perlu memikirkan masalah yuran dan kos buku-buku rujukan. Ini dibuktikan dengan pencapaian keputusan peperiksaan mereka yang semakin baik berbanding sebelum ini. Masalah seperti duit poket dan tambang pengangkutan juga boleh dilihat semula oleh LZNK untuk anak-anak asnaf yang tinggal jauh dari asrama. Begitu juga dengan bantuan komputer untuk anak-anak yang belajar di IPT yang tidak mampu memiliki kemudahan tersebut untuk menyelesaikan kerja kursus mereka di kampus. Pemberian bantuan nutrisi yang sihat untuk kesihatan anak-anak asnaf perlu diberi perhatian oleh LZNK.

Untuk kajian akan datang, penelitian perlu dibuat dari aspek sejauhmana impak seluruh bantuan kewangan dan program pendidikan yang dilaksanakan oleh LZNK kepada asnaf-asnaf yang terlibat. Ini kerana setiap wang zakat yang dibelanjakan perlu dinilai pulangnya kepada pembangunan sosioekonomi ummah.

PENGHARGAAN

Penulis mengucapkan setinggi-tinggi penghargaan kepada Universiti Utara Malaysia dan Lembaga Zakat Negeri Kedah kerana membiayai penyelidikan ini melalui Geran IPIZ. Kertas kerja ini adalah sebahagian daripada hasil penyelidikan yang bertajuk “Keberkesanan Agihan zakat Dalam Pembangunan Pendidikan Anak-anak Asnaf di Kedah” di bawah Dana Geran IPIZ, Universiti Utara Malaysia, Kod S/O 14121.

RUJUKAN

- Ab Rahman, A., & Anwar, S. M. (2014). Dana Zakat dalam Pendidikan Asnaf dan Sumbangannya Terhadap Ekonomi Malaysia. *Proceeding, Persidangan Kebangsaan Ekonomi Malaysia ke-9, Kuala Terengganu, Terengganu*, 17-19.
- Berita Harian (2019, 11 Oktober). Pendidikan terima peruntukan tertinggi. Retrieved from <https://www.berita.com.my/berita/pendidikan/2019/10/616641/pendidikan-terima-peruntukan-tertinggi>
- Cavana, R. Y., Delahaye, B. L., & Sekaran, U. (2001). *Applied Business Research : Qualitative And Quantitative Methods*. John Wiley & Sons Australia, Ltd.
- Creswell, J. W. (1998). *Qualitative Inquiry And Research Design : Choosing Among Five Traditions* (1st ed.). California: SAGE Publications.
- Creswell, J. W. (2009). *Research Design : Qualitative, Quantitative, and Mix Method Approaches* (3rd ed.). California: Sage Publication, Inc.
- Creswell, J. W. (2014). *Research Design : Qualitative, Quantitative, and Mix Method Approaches* (4th ed.). SAGE Publications.
- Hamim Hafiddin. (2015). Pendidikan Islam Pada Masa Rasulullah. *Jurnal Tarbiya* Volume: 1 No: 1. Bandung: Universitas Islam Negeri Sunan Gunung Jati.
- Hamizul Abdul hamid (2017). Menangani Kemiskinan Melalui Pendidikan Asnaf: Pengalaman Lembaga Zakat Selangor. Dibentangkan di Persidangan Pilantropi Untuk Bantuan Kemanusiaan 2017, pada 26 – 27 Sya’aban 1438 / 23 – 24 May 2017, di Universiti Islam Sultan Sharif Ali (UNISSA), Negara Brunei Darussalam.
- Marzuki, M., Majabil, J., & Mohd Zainol, R. (2014). Mengupas keciciran pelajar Orang Asli Malaysia: Suatu tinjauan ke dalam isu aksesibiliti sekolah. *GEOGRAFIA Online Malaysian Journal of Society and Space*, 10(2), 189-198.
- Mohammed Yusoff (2011). Zakat Expenditure, School Enrollment, and Economic Growth In Malaysia. *International Journal of Business and Social Sciences*, 2(6).
- Mohammed Yusoff (2014). Zakat Distribution, Education, And Real Income Per Capita In Malaysia. *Journal Of Strategic and International Studies*, VI(3).
- Merriam, S. B. (2009). *Qualitative Research : A Guide To Design and Implementation*. San Francisco: Jossey-Bass.
- Miles, M. B., Huberman, A. M., & Saldana, J. (2014). *Qualitative Data Analysis : A Method Sourcebook* (3rd Editio). United States: Sage Publication, Inc.
- Othman, Y., & bin Abdul Mukti, M. F. (2018). Memperkasa Institusi Pendidikan Melalui Agihan Balik Zakat. *International Journal of Muamalat*, Vol.2, Issue 1
- Patton, M. Q. (2002). *Qualitative Research & Evaluation Methods* (3rd ed.). California: Sage Publication, Inc.
- Radzi, N. M., & Ahmad, N. A. (2017). Peranan zakat dalam meningkatkan ekuiti dalam pendidikan anak-anak miskin bandar di Malaysia. *JuPiDi: Jurnal Kepimpinan Pendidikan*, 4(3), 1-13.
- Rashid, S. M. R. A., & Samat, N. (2018). Kemiskinan keluarga dan pengaruhnya terhadap tahap pendidikan rendah masyarakat luar bandar: Kajian kes di jajahan Bachok, Kelantan (Family poverty and its influence on rural community low education: Case study in Bachok District, Kelantan). *e-Bangi*, 15(2).
- Sinar Harian (2019, 23 Mei). LZNK Peruntuk RM6.13 juta Bantuan Pendidikan. Retrieved from <https://www.sinarharian.com.my/article/29603/EDISI/Utara/LZNK-peruntuk-RM613-juta-bantuan-pendidikan>
- Shenton, A. K. (2004). Strategies for ensuring trustworthiness in qualitative research projects. *Education for Information*, 22, 63–75. <http://doi.org/10.1111/i.1744-618X.2000.tb00391.x>
- Taib, M. S. M., Mujani, W. K., Rozali, E. A., & Talib, K. A. (2017). Perkembangan Wakaf Pendidikan Tinggi di Malaysia. *International Journal of West Asian Studies*, 9(1).

- Tamuri, A. H., Mahmud, Z., & Bari, S. (2005). Permasalahan pelajar-pelajar fakir miskin di daerah Sabak Bernam. *Jurnal Pendidikan*, 30, 21-33.
- Temu bual dengan pihak pengurusan Lembaga Zakat Negeri Kedah, Alor Setar pada 9 Januari 2019 jam 10 pagi.
- Wan Afizi Wan Hanafi, Shaharuddin Ahmad dan Noraziah Ali. (2014). *Faktor Budaya dan Persekitaran Dalam Prestasi Pendidikan Anak Orang Asli Malaysia: Kajian Kes di Kelantan*. GEOGRAFIA Online Malaysian Journal of Society and Space 10, Issue 5. Bangi: Universiti Kebangsaan Malaysia.
- Zakiah Jamaludin (2011) Kemiskinan dan keciciran dalam pendidikan. *Jurnal Kebajikan Masyarakat*, 37. pp. 5-17.
- Zin, N. A. M., & Tambi, N. (2018). Faktor Kemiskinan Bandar terhadap Pembangunan Pendidikan Golongan Lewat Kembang (Factors of Urban Poverty towards the Development of Late Bloomer's Education). *Jurnal Psikologi Malaysia*, 32(3).

ASSESSING HALAL AWARENESS AND DETERMINANTS OF HALAL PURCHASING INTENTIONS AMONG ADOLESCENTS IN MALAYSIA

Shahida Abd. Latif^a, Siti Hawa Mohd Yusoff^b, Yati Ashikin Abd Wahab^c, Hafizan Hashim^d, & Hanita Hashim^a

^{abc}Faculty of Engineering and Life Sciences, Universiti Selangor, Malaysia
^dFaculty of Mechanical Engineering, Universiti Teknologi MARA, Malaysia

Abstract

The halal market has grown exponentially over the last few years. Besides, the rising number of Muslim populations in Malaysia has increased the demand for halal products. Due to this matter, the study on halal has been done towards halal products regarding the halal awareness and exposures of adolescent consumers. This study aims to explore the awareness of adolescents about halal products and to investigate their purchasing behavior towards halal products using the Theory of Planned Behavior (TPB). This study uses multiple regression and correlation analysis to identify the factors affecting halal products purchasing behavior among adolescents. The results show that the TPB is a valid model for predicting adolescent intention to purchase halal products and all the factors have a positive and significant influence on halal products purchasing behavior. The results also show that religiosity is more prominent towards behavior compared to knowledge concerning halal matters. The level of awareness towards halal products is high, and that the effect of awareness on the purchase decision is significant. The study also revealed that adolescents are aware of and concern with the halal information and issues among them. This study could be useful for halal industry to understanding and identifying halal products purchasing behavior among adolescents in Malaysia.

Keywords: Consumer behavior, Teenager, Halal-labelled, Purchase decision, Theory of Planned Behaviour model (TPB)

1.0 INTRODUCTION

The Halal products industry is continuously growing due to the increase number of Muslim populations. Today, the total number of Muslims are approximately 1.6 billion composing about 23% of the world population, and this number is estimated to increase to 2.2 billion or 26% by 2030 (Calabria, 2018). The growing concern among the Muslims about Halal food (Sungkar, 2010; Teng et al., 2013) as well as the increasing trend in attitude and intention to purchase Halal food by non-Muslims (Golnaz et al., 2013) escalated the demand that leads to the growth of this industry.

According to Rezai et al. (2008), Halal refers to a code of conduct which is permitted by Syariah and it applies to every activity handled by a Muslim. Baharudin et al. (2012) stated that Halal is the universal term that applies to all facet of life. The word Halal is not only used in the context of consumables or product used by Muslims, it has a varied scope of application which covers from an inter-human relationship, clothing and manner, social and business transaction, trade and financial services to investment or any others which are in compliance with the laws of Islam (Muhammad et al., 2009). For example, when applied to the economy concept, it refers to a business organized in a manner deemed permissible in Islam. When it applied to food, it refers to the entire food chain that operated within Islamic guidelines.

The Halal foods concept is now recognized by worldwide as an alternative benchmark for safety, hygiene and quality assurance of what we consume or use daily. The Halal products that are processed in line with Halal prescriptions are readily acceptable by all including the non-Muslim consumers (Ambali & Bakar, 2014).

The adolescents understanding about the Halal concept and practices need to be studied in order to find out whether the young generation of Malaysia aware about the Islamic law of Halal. The Halal concept might not fully understandable especially among Malaysian adolescents because of the difference in religion practices. The young generation also have little experience as they are still young and do not have enough exposure to the Halal concept.

The non-Muslim adolescents may have no knowledge about Halal as the Halal concept is not applied to non-Muslim lifestyle.

The mixture of different races and religion practices in Malaysia makes the food sectors need to produce variety of food products in order to fulfill the consumer needs especially for society with different races and religion. The result of that makes the food produced in Malaysia divided into Halal and not Halal. The society might confused with the mix of Halal and not Halal food product sold in the market.

The Islamic rule of Halal is very important to Muslim as it is a part of Islamic teaching that need to be followed by every Muslim. Islam teaches many ways to prepare and consume the Halal foods such as Islamic slaughtering process, equipment cleanliness, and Halal food source selection. This rules and procedure might confuse the non-Muslim and give difference in understanding about the true Halal concept.

The Halal guideline that sets by Malaysian authorities like Department of Islamic Development Malaysia (JAKIM) need to be followed by the food product manufacturer to make sure the food product that sold in the market is fully Halal and not tampered with any Hara elements. The rule of Halal needed to be synchronized with the consumer needs to ensure the benefits to both Muslim and non-Muslim. The Halal practices also can lead to better and safer food product consumptions.

Owing to the increasing demand for halal food in the world's market, many Muslim consumers are feeling doubtful and unconfident that the foods that are sold to the market might encourage some countries to think about halal food processing. Much of the research reports on halal food markets are predicted but there is dearth of theory-driven research on halal food purchasing. In general terms, theory-driven research facilitates a better understanding of the attitudinal and behavioral factors that influence a particular behavior, allows researchers to propose and test causal models of the behavior, and ultimately facilitates effective design and implementation of programs that aim to promote the behavior.

Thus, the main objective of this study is to explore how the theory of planned behaviour model (TPB) could facilitate in predicting the purchase intention to halal products among adolescents in Malaysia. Looking at the current scenario, the purpose of this study is to examine the major determinants of halal purchasing intentions among adolescents in Malaysia. This study uses multiple regression and correlation analysis to determine the relationship and factors affecting halal products purchasing behavior among adolescents.

2.0 METHODOLOGY

Halal is an Arabic word that means lawful or allowable in Islam which applies to all parts of life, not only food and drinks. Halal is part of a belief system and moral code of conduct in Islam, which is a part of the daily living of the Muslim community (Chowdhury & Islam, 2018). It relates to the acceptance and popularity of Halal products to the religious beliefs that it is tastier, healthy, and more hygienic than Haram foods (Al-Harran & Low, 2008). For an instant, Halal food has a low percentage rate regarding contamination, defilement, or adulteration. The process of Halal food/ products agrees to the principles of food/product hygiene set by their religion. Hence, Halal food/products are considered safer for consumption (Billah et al., 2020). In Malaysia Halal food/ product was certified by the JAKIM.

The theory of planned behaviour model (TPB) was found to be a good estimator of halal product or food purchase intention among consumers in Malaysia. The TPB has widely used to identify factors that predict and measure behaviours (Ajzen, 1985). It measures the factors based on a person's attitudes, subjective norms (i.e. influence from other individuals) and perceived behavioural control. Figure 1 shows the research framework for the purchase intention of Halal products among adolescents. The factor of awareness has a relationship with purchase intention. While, attitude, subjective norms, and perceived behavioural control also have direct relationships with purchase intention.

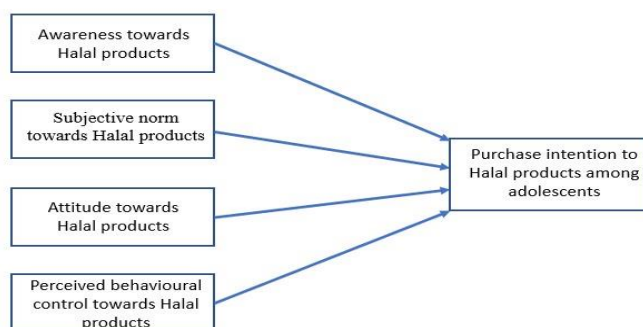

Figure 1: The research framework of intention to purchase of Halal products among adolescents according to the theory of planned behaviour.

2.1 Attitude

According to Ajzen and Fishbein (1985), a person's attitude towards behaviour refers to his or her positive or negative evaluation/appraisal of the behavioural performance. Attitude is a predictor of consumers' intention to purchase, especially in the food category (Iranmanesh et al., 2019). The major concern of Muslim consumers in Malaysia is the state of halal of food products. Muslim consumers generally will not accept and will not consume food products that are not certified as halal by the Malaysian religious authority (Haque et al., 2015). Other studies confirm that consumer attitude towards halal food has a significant and positive influence on purchasing intention (Bashir et al., 2018; Kamalul Ariffin et al., 2019).

The following hypothesis was proposed for testing:

H1: There is a positive significant relationship between attitude and intention to purchase halal food products.

2.2 Subjective Norm

Subjective norm refers to perceived social pressure to comply with expectations from other individuals and perceived behavioural control is the feeling of being in control or the confidence in performing a behaviour (Vanany et al., 2019). In the previous study made by Asnawi et al., (2018), Muslim consumers tend to less consider references of friends, family, or groups before they decide to consume halal products. They are more to collectivist society. The reason is the decision of consuming halal products is part of their intrinsic part of their religiosity. Similar finding by (Marmaya et al., 2019) found that young consumers who normally are more self-determining in making decisions of the food that they take.

Thus, the following hypothesis was proposed:

H1: There is a positive significant relationship between subject norm and intention to purchase halal food products.

2.3 Perceived Behavioural Control

Perceived behavioural control is described as a perception of the extent to which the behaviour is assumed to be controllable. It assesses the degree to which people perceive that they have control over enacting to perform a behaviour (Helmyati et al., 2019). This indicates that perceived behaviour control is the thing that can be controlled in terms of whether to purchase something or not. A study done by (Kamalul Ariffin et al., 2019), found out that perceived behaviour control shows a significant effect on purchase intention towards halal products. In terms of non-muslim consumers, perceived behavioural control has a positive influence on non-Muslim consumers repurchase intention of halal food (Damit et al., 2019). A product's halal status is not just an assurance that the product is permissible for Muslim consumption, but it has also become a global symbol of quality and lifestyle choice (Elasrag, 2016). In this study, the perceived behavioural control has been classified into whether the respondent Muslim or non-Muslim, age group of adolescents, and the education level of adolescents.

Thus, the following hypotheses were proposed for testing:

H₁: There is a positive significant relationship between perceived behavioural control and intention to purchase halal food products.

H₁: There is a significant difference between Muslim and non-Muslim adolescents in their intention to purchase halal products.

H₁: There is a significant difference in the intention to purchase halal products irrespective of their age group.

H₁: There is a significant difference in the intention to purchase halal products irrespective of their education level.

2.4 Halal Awareness

Awareness of halal means having a particular concern in or experience of halal, besides being knowledgeable of halal foods, drinks, and products (Ambali & Bakar, 2014). Awareness refers to the understanding and information about specific things (Aziz & Chok, 2013). A study by Mutmainah (2018) concluded that halal awareness has a positive significant effect on consumer purchase intention on halal food. A finding from Akin & Okumus, (2020) found out that consumers like to know about a particular product, brand, or company. In this study, the factors that contributed to Halal awareness have been classified into whether the respondent Muslim or non-Muslim, age group of adolescents, and the education level of adolescents.

Hence, the following hypotheses were tested:

H₁: There is a positive significant relationship between awareness and intention to purchase halal food products.

H₁: There is a significant difference between Muslim and non-Muslim adolescents in their halal awareness.

H₁: The halal awareness is not the same irrespective of their age group.

H₁: The halal awareness is not the same irrespective of their education level.

2.5 Data collection

The data were obtained through a survey instrument and the variables associated with the proposed model were included in the questionnaire. There are 212 of respondents whose answer the questionnaire and all the respondents are from age 13 to 21 years old. The demographic information comprises gender, race, religion, age, and education levels.

To achieve the objectives of the study, there are three statistical techniques were performed which are independent t-test, one-way analysis of variance (ANOVA) and, correlation and multiple regression.

2.6 Independent T-Test

The independent t-test is a statistical technique used to compare the means of two groups of independent samples and one dependent sample by using t-test distribution. The independent t-test is a parametric test that has 2 assumptions, which are normally distributed populations and independent samples.

It will test the following hypothesis:

H₀: The mean of the two groups are equal.

H₁: The mean of the two groups are not equal.

If the *P*-value is less than the significance value of α , then the H₁ will be concluded and the mean of the two groups is not equal.

2.7 One-Way Analysis of Variance

The one-way analysis of variance (ANOVA) is a statistical technique used to compare the means of two or more groups of independent samples and one dependent sample by using *F*-distribution. One-way ANOVA is a parametric test that has 3 assumptions, which are normally distributed populations, homogeneity of variances, and independent samples.

It will test the following hypothesis:

H₀: All means are equal.

H₁: At least one means are not equal.

If the *P*-value is less than the significance value of α , then the H₁ will be concluded and at least one means are not equal.

2.8 Correlation and Multiple Regression

A correlation is a statistical technique used to measure the strength of the linear association of two variables. It is denoted by *r* and the value are taken place from -1 to +1. If $r = -1$, it is indicated a perfect negative linear relationship. If $r = +1$, it is indicated a perfect positive linear relationship between two variables. While, if $r = 0$, it is indicated no linear relationship between the two variables.

Regression is a statistical technique used to predict the linear relationship between one or more independent variables, X and one dependent variable, Y.

The following is a general equation of multiple regression:

$$Y_i = \beta_0 + \sum_{k=1}^{p-1} \beta_k X_{ik} + \varepsilon_i \quad (1)$$

Where:

$\beta_0, \beta_1, \dots, \beta_{p-1}$ are parameters, $X_{i1}, \dots, X_{i,p-1}$ are known constants, and ε_i are independent.

The regression will perform the following hypothesis test by using:

H₀: There is no linear relationship between X and Y.

H₁: There is a linear relationship between X and Y.

If the *P*-value is less than the significance value of α , then the H₁ will be concluded and there is a linear relationship between X and Y.

3.0 ANALYSIS AND FINDINGS

This study was conducted through a questionnaire with 212 adolescents in Malaysia. All the respondents have successfully completed the questionnaires.

3.1 Demographic information

This section discusses the frequency and percentage of demographic information. Based on Table 1, the majority of the respondents were girls compared to boys. The age distribution has shown 34% were from lower secondary school which aged 13 to 15 years old. Followed by upper secondary school aged from 16 to 18 years old which 37.7%. Besides that 19-21 years old have found only 28.3% which come from higher institution students. In this research, 68.9% of the respondents were Malay, 6.6% were Indian and Chinese, and 24.5% of the respondents have come from Bumiputera Sabah and Sarawak. Majority of the respondents were Muslim, about 84.4%, and the rest is non-Muslim respondents.

Table 1. Summary of demographic information

	Frequency	%
Gender		
Boy	74	34.9%
Girl	138	65.1%
Race		
Malay	146	68.9%
Indian / Chinese	14	6.6%
Bumiputera Sabah / Sarawak	52	24.5%
Religion		
Muslim	179	84.4%
Non-Muslim	33	15.6%
Age group		
13 – 15	72	34.0%
16 – 18	80	37.7%
19 – 21	60	28.3%
Education level		
Lower secondary (Form 1 – 3)	72	34.0%
Upper secondary (Form 4 – 6)	74	35.0%
Foundation / Diploma / Degree	66	31.0%

3.2 Reliability Test

The reliability test was performed to check the consistency of the items by calculating the Cronbach's Alpha coefficients. Table 2 shows the Cronbach's Alpha values were 0.708, 0.753, 0.704, and 0.755 which indicate the reliability of the items for the study.

Table 2. Reliability statistics

Dimensions	Cronbach's Alpha
Halal awareness	0.884
Subjective Norm	0.753
Attitude towards halal product	0.704
Perceived Behavioural Control	0.755

3.3 Mean Score of Halal Awareness and intention to purchase halal products

According to Mohd. Majid Konting (2000), the interpretation of the mean score is considered low if the mean score is 1.00-2.33, moderate (mean score = 2.34 – 3.67), and high (mean score = 3.68 – 5.00). The mean score of halal awareness was listed in Table 3. The mean score for religion observed that Muslim respondents are more aware of the halal products compared to non-Muslim respondents. This result is in line with the race that showed Chinese and Indian has lower awareness compared to Malay and Bumiputera Sabah Sarawak. However, overall adolescents are aware of the halal products. Next, Table 4 showed the results for the mean score of intention to purchase the halal products. From the table showed that Malay and Muslim adolescents have a high level of intention to purchase halal products compared to non-Muslim adolescents.

Table 3: Mean score of halal awareness

Variables	Mean	Standard Deviation	Interpretation
Religion			
Muslim	4.21	0.7440	High
Non muslim	3.62	0.9459	Moderate
Age group			
13-15	4.21	0.7951	High
16-18	4.22	0.7049	High
19-21	3.87	0.8962	High
Race			
Malay	4.24	0.7228	High
Chinese / Indian	3.61	1.0240	Moderate
Bumiputera Sabah/ Sarawak	3.92	0.8809	High

Table 4: Mean score of intention to purchase halal products

Variables	Mean	Standard Deviation	Interpretation
Religion			
Muslim	4.26	0.6421	High
Non muslim	3.13	0.7705	Moderate
Age group			
13-15	4.01	0.7898	High
16-18	4.02	0.8391	High
19-21	4.25	0.6536	High
Race			
Malay	4.30	0.6213	High
Chinese / Indian	3.45	0.7703	Moderate
Bumiputera Sabah/ Sarawak	3.65	0.9080	Moderate

3.4 Normality test

Table 5 indicates that the data is not normal since the p-value = 0.000 is less than $\alpha = 0.05$. However, this result is still acceptable in the context of large sample sizes due to their ability to reduce errors in a study. Pallant (2007) said that the parametric techniques can be continued if the sample size is large. This was agreed by John E. Freund (2012) where the value of sample size greater than 30, the distribution of population can be closely approximated by a normal distribution. According to George and Mallery (2010), if skewness is between -2 and +2, the data can be considered as the normal distribution. Based on the Table 6, the values of skewness are between -2 and +2, thus this data is considered normally distributed.

Table 5: Normality test

	Kolmogorov-Smimov		
	Statistic	df	Sig.
Mean score of Religiosity	0.140	212	0.00
Mean score of Subjective Norm	0.168	212	0.00
Mean score of Attitude towards halal product	0.143	212	0.00
Mean score of Perceived Behavioural Control	0.131	212	0.00

Table 6: Descriptive statistics

	Mean	Standard Deviation	Skewness
Mean score of Religiosity	3.9198	.88333	-.804
Mean score of Subjective Norm	4.1352	.88968	-1.152
Mean score of Attitude towards halal product	3.8896	.64587	-.838
Mean score of Perceived Behavioural Control	3.6387	.83036	-.493

3.5 HYPOTHESIS TESTING

3.5.1 Independent sample *t*-test

This part will elaborate the result of independent *t*-test used in the mean score of halal awareness and intention to purchase halal product between muslim and non muslim adolescents.

H1: There is significant difference between muslim and non muslim adolescents in their intention to purchase halal product.

H2: There is significant difference between muslim and non muslim adolescents in their halal awareness.

Table 7: Independent samples *t*-test

		Levene's Test for Equality of Variances		t-test for Equality of Means				
		F	Sig.	t	df	Sig. (2-tailed)	Mean Difference	Std. Error Difference
H1 : There is significant difference between muslim and non muslim adolescents in their intention to purchase halal product.	Equal variances assumed	2.708	.101	8.926	210	.000	1.12147	.12564
	Equal variances not assumed			7.875	40.604	.000	1.12147	.14241
H2 : There is significant difference between muslim and non muslim adolescents in their halal awareness.	Equal variances assumed	3.812	.052	3.963	210	.000	.58413	.14741
	Equal variances not assumed			3.360	39.617	.002	.58413	.17383

Table 7 indicated that equal variances were assumed since the *p*-values is more than $\alpha = 0.05$. Therefore, it can be concluded there are significant differences between Muslim and non-Muslim adolescents towards halal awareness and their intention to purchase halal products (*p*-value = 0.000).

3.5.2 Analysis of variance

This part will elaborate the result of analysis of variance (ANOVA) which testing the halal awareness to the respective item in demographic information.

H3 : The halal awareness is different with respective to their age group.

H4 : The halal awareness is different with respective to their education level.

H5 : There is significance difference of the intention to purchase halal product irrespective to their age group.

H6 : There is significance difference of the intention to purchase halal product irrespective to their education level.

Table 8: ANOVA table of halal awareness towards the age group and education level.

	Mean	Standard deviation	F	Sig.
Age group				
13-15	4.21	0.7951	0.158	0.854
16-18	4.22	0.7049		
19-21	3.87	0.8962		
Education status				
Lower secondary	4.24	0.7228	1.965	0.143
Upper secondary	3.61	1.0240		
Foundation / Diploma / Degree	3.92	0.8809		

From the Table 8, results show that both *p*-values are more than $\alpha = 0.05$. It indicates that no matter what age the student is, and any education level status, all the respondents were aware about the halal product in Malaysia. This result is in line with the results gathered from Table 3 about the mean score of awareness of halal product.

Table 9: ANOVA table of intention to purchase halal product towards the age group and education level.

	Mean	Standard deviation	F	Sig.
Age group				
13-15	4.01	0.7898	0.083	0.773
16-18	4.02	0.8391		
19-21	4.25	0.6536		
	Mean	Standard deviation	F	Sig.
Education status				
Lower secondary	4.30	0.6213	1.132	0.289
Upper secondary	3.45	0.7703		
Foundation/Diploma/Degree	3.65	0.9080		

Next, from Table 9, results show that both p -values are more than $\alpha = 0.05$. It indicates that no matter what age the student is, and any education level status, all the respondents were intent to purchase halal products in Malaysia. This result is in line with the results gathered from Table 4 about the mean score of intention to purchase the halal products.

3.6 Correlation

Table 10: Correlation

	Religiosity	Subjective Norm	Attitude	Perceived Behavioural Control	Intention to Purchase Halal Product	Halal Awareness
Religiosity	1.000					
Subjective Norm	0.423**	1.000				
Attitude	0.363**	0.607**	1.000			
Perceived Behavioural Control	0.421**	0.640**	0.756**	1.000		
Intention to Purchase Halal Product	0.355**	0.647**	0.617**	0.656**	1.000	
Halal Awareness	0.473**	0.597**	0.496	0.570**	0.709**	1.000

*Correlation is significant at the 1% level.

In this part, data were analyzed using correlation to test the relationship between variables. All the hypotheses were tested by using the coefficient of correlation to analyze the linear relationship among variables. The results from Table 10 show that all variables have a positive and significant relationship. There is a strong positive linear relationship between attitude and perceived behaviour control about 0.756. Halal awareness and intention to purchase halal product also show the high correlation of 0.709 which indicate that more adolescents are aware about halal products, the more their intention to purchase that halal products.

3.7 Regression

This section will discuss the multiple regression model of intention to purchase halal products towards the TPB model. This analysis is to model the regression and to understand whether adolescent's intention to purchase the halal products can be predicted based on the TPB model which is, subjective norm, attitude, perceived behavioural control, and halal awareness.

3.7.1 Multicollinearity and autocorrelation

This section is done to detect if the independent variable in the regression is correlated because the independent variable should be independent of each other. This important to prevent any problem occurred during fitting the model and interpretation of the result. The variance inflation factor (VIF) is a method used in this study to detect the percent of multicollinearity. This factor is used to measure how much the variance of the estimated regression coefficient is enlarged as compared when the independent variables are not linearly related. Based on Table 13, the VIF for all independent variables is less than 10, which indicates the presence of no multicollinearity problem in this model. While none of the tolerance levels is less than 0.01.

Durbin Watson statistic is used to test the autocorrelation of intention to purchase the halal product. Durbin Watson statistic gives a value of 1.813 which falls outside of the range for Durbin Watson analysis between 1.728 and 1.810. The results show there is no proof of autocorrelation detected in this model. Thus, the independent model in this model, do not reach the level of multicollinearity and autocorrelation.

3.7.2 Regression analysis

The following hypotheses were developed to study the positive relationship between intention to purchase the halal product and the listed independent variables.

H7: There is a significant and positive relationship between subjective norm and intention to purchase halal product.

H8: There is a significant and positive relationship between attitude and intention to purchase halal product.

H9: There is significant and positive relationship between perceived behaviour control and intention to purchase halal foods products.

H10: There is significant and positive relationship between halal awareness and intention to purchase halal foods products.

Table 13: Regression results for Intention to Purchase Halal Product

Variables	Beta	T-test	Significance	Tolerance	VIF
Constant	0.386	1.757	0.080		
Subjective Norm	0.163	3.090	0.002	0.487	2.055
Attitude	0.198	2.482	0.014	0.402	2.487
Perceived Behavioural Control	0.164	2.480	0.014	0.357	2.801
Halal Awareness	0.402	7.538	0.000	0.583	1.715
Adjusted R squared	0.625		Durbin-Watson	1.813	
F value	89.006				
Significance	0.000				

Dependent variable: Intention to purchase halal product

Table 13 presents the results of an individual and multiple linear regression analysis was used to evaluate the strength of the proposed relationship from the hypotheses. Four hypotheses were carried out and the reliability of all variables are being tested. The results support H7 to H10 which is, the relationship between subjective norm (p -value = 0.002), attitude (p -value = 0.014), perceived behavioural control (p -value = 0.014) and halal awareness (p -value = 0.000). The overall results for multiple regression also show the significant result which indicates that intention to purchase halal can be predicted by using subjective norm, attitude, perceived behavioural control, and halal awareness. This finding is good news because it means all independent variables in this model improved the fit.

4.0 CONCLUSION

Building on the TPB and halal awareness factors, this study empirically provided evidence of the significant relationships between halal awareness, subjective norm, attitude and perceived behavioural control with purchase intention to halal products using data collected with adolescents in Malaysia.

The model was statistically significant and this study results demonstrates, the robustness of the TPB for helping to explain halal products purchasing intention. Other studies have also successfully used the TPB as a theoretical framework from which to examine the purchase intention (Bredahl et al., 1998). The study depicted that attitude has a significant and positive effect on halal products purchasing intention. Attitude is an important factor in influencing consumer intention in purchasing halal products because those with high positive attitudes appeared to have greater intentions to intent to purchase halal products. Social pressure may compensate for high favorable attitudes in building intentions to purchase halal products in such culture.

Consistent to the study of Karijin et al. (2007), the research found that subjective norm was positively and significantly related to intention. This study also confirms other studies like Kamariah and Muslim's (2007) which found subjective norms to be important. In more individualistic cultures like Western cultures, people perceived themselves as autonomous and independent of the group and prioritized personal goals over collective goals, which would lead to a higher use of personal attitude versus social norms in behavioral decisions.

On the other hand, in collectivistic cultures such as the Muslim culture, people tend to perceive themselves as interdependent with their group and tend to strive for in-group rather than personal goals (Karijin et al., 2007). This is matched with the findings of this study that subjective norm is important in influencing consumers' purchase intention, especially in Malaysia, a collectivistic country.

Furthermore, based on the present findings, perceived behavioural control is not a critical predictor on behavioural intention ($p > 0.05$). However, this finding, contrary to the findings by Bonne and Verbeke (2006), found that

Muslims are more willing to put considerable effort in obtaining halal food (Karijin et al., 2007), which means perceived behavioural control is an important factor in influencing consumer to purchase halal products. The study also confirmed that perceived behavioural control has a significant effect on halal products purchasing intention. The relationship is a positive relationship which means that the greater impact of control in explaining variability in behaviour is not unusual. Eagly and Chaiken (1993) and Bonne and Verbeke (2006) summary studies concerning various behavioural criteria have reported similar findings. Ajzen (1991) suggested that control could directly affect behaviour by increasing effort to goal achievement.

Overall, our study has provided evidence of the existence of halal awareness among the Muslim or non-Muslim adolescents, age group of adolescents, and the education level of adolescents in Malaysia. Our study highlights that the TPB model is effective in examining the consumer's behaviour purchase intention towards halal products. Finally, this study has added to the current body of knowledge relating to general concept of halal products awareness and consumer behaviour in a developing multicultural country. It has the potential to be the basis of further explorations of halal products industry within other countries and other societies.

REFERENCES

- Ajzen, I. (1985), "From intentions to actions: A Theory of Planned Behaviour", in, J. Kuhl and J. Beckmann (eds.). *Action Control: From Cognition to Behaviour*. Springer Berlin Heidelberg, pp. 11-39.
- Ajzen, I. and Fishbein, M. (1985), "The prediction of behaviour from attitudinal and normative variables", *Journal of Experimental Social Psychology*, Vol. 6 No. 4, pp. 466-488.
- Ajzen, I. (1991), "Theory of planned behavior", *Organization Behavior and Human Decision Process*, Vol. 50, pp. 179-211.
- Al-Harran, S., & Low, K. (2008). Marketing of halal products: The way forward. *The Halal Journal*, 44-46.
- Akin, M. S., & Okumus, A. (2020). Shaping the consumers' attitudes towards Halal food products in Turkey. *Journal of Islamic Marketing*. <https://doi.org/10.1108/JIMA-08-2019-0167>
- Ambali, A. R., & Bakar, A. N. (2014). People's Awareness on Halal Foods and Products: Potential Issues for Policy-makers. *Procedia - Social and Behavioral Sciences*, 121(September 2012), 3-25. <https://doi.org/10.1016/j.sbspro.2014.01.1104>
- Asnawi, N., Sukoco, B. M., & Fanani, M. A. (2018). Halal products consumption in international chain restaurants among global Moslem consumers. *International Journal of Emerging Markets*, 13(5), 1273-1290. <https://doi.org/10.1108/IJoEM-11-2017-0495>
- Aziz, Y. A., & Chok, N. V. (2013). The Role of Halal Awareness, Halal Certification, and Marketing Components in Determining Halal Purchase Intention Among Non-Muslims in Malaysia: A Structural Equation Modeling Approach. *Journal of International Food and Agribusiness Marketing*, 25(1), 1-23. <https://doi.org/10.1080/08974438.2013.723997>
- Baharudin, M. H. A. B. M. (2012). Syariah Compliant Dalam Industri Perhotelan di Malaysia: Kajian Hotel De Palma Ampang, Selangor in Malay. Unpublished Master's Thesis, Universiti Teknologi Malaysia.
- Bashir, K. M. I., Kim, J., Mohibullah, M., Sohn, J. H., & Choi, J.-S. (2018). Strategies for improving the competitiveness of Korean seafood companies in the overseas halal food market. *Journal of Islamic Marketing*. <https://doi.org/10.1108/JIMA-03-2018-0056>
- Bonne, K. and Verbeke, W. (2006), "Muslim consumer's attitude towards meat consumption in Belgium: insights from a means-end chain approach", *Anthropology of Food*, Vol. 5.
- Bredahl, L., Grunet, K.G. and Frewer, I. (1998), "Consumer attitudes and decision-making with regard to genetically engineered food products - a review of the literature and a presentation models for future research", *Journal of Consumer Policy*, Vol. 21, pp. 251-77.
- Calabria, M. D. (2018). The flowering of India: A Mughal Manifesto for environmentalism. In M. Shafiq, & T. Donlin-Smith, *Nature and the Environment in Contemporary Religious Contexts* (pp. 251-271). Cambridge Scholars Publishing.
- Damit, D. H. D. A., Harun, A., Martin, D., Othman, B. J., Othman, B., & Ahmad, H. (2019). What makes a non-muslim purchase halal food in a muslim country? An application of theory of planned behaviour. *Management Science Letters*, 9(12), 2029-2038. <https://doi.org/10.5267/j.msl.2019.7.003>
- Eagly, A.H. and Chaiken, S. (1993), *The Psychology of Attitude*, Harcourt Brace Jovanovich, Forth Worth, TX.
- Elasrag, H. (2016). Halal Industry : Key Challenges and Opportunities Hussein Elasrag. *SSRN Electronic Journal*, February.
- George, D., & Mallery, M. (2014). SPSS for Windows Step by Step: A Simple Guide and Reference, 17.0 update (10a ed.) Boston: Pearson.
- Golnaz, R., Zainalabidin, M., Mad Nasir, S. and Eddie Chiew, F.C. (2010). Non-Muslims' awareness of Halal principles and related food products in Malaysia. *International Food Research Journal*, 17, 667-674.
- Haque, A., Sarwar, A., Yasmin, F., Tarofler, A. K., & Hossain, M. A. (2015). Non-Muslim consumers' perception toward purchasing halal food products in Malaysia. *Journal of Islamic Marketing*, 6(1), 133-147. <https://doi.org/10.1108/JIMA-04-2014-0033>
- Helmyati, S., Siagian, R. Y., Nisa, F. Z., Radhiya, S., & Yuliati, E. (2019). Predicting the Halal Food Consumption of Indonesian Moslem Students: an Application of Theory of Planned Behaviour. *Jurnal Gizi Dan Pangan*, 14(1), 45-52. <https://doi.org/10.25182/jgp.2019.14.1.45-52>
- Iranmanesh, M., Mirzaei, M., Parvin Hosseini, S. M., & Zailani, S. (2019). Muslims' willingness to pay for certified halal food: an extension of the theory of planned behaviour. *Journal of Islamic Marketing*, 11(1), 14-30. <https://doi.org/10.1108/JIMA-03-2018-0049>
- John E. Freund (2012). *Mathematical Statistics with Application*, 8th Ed. Pearson.
- Kamalul Ariffin, S., Dihanani, N. N., & Wahid, N. (2019). Investigating the Factors Affecting Consumer Purchase Intention towards Halal Organic Food. *Journal of Entrepreneurship, Business and Economics*, 7(2), 162-188. www.scientificia.com
- Kamariah, N. and Muslim, N. (2007), "The application of theory of planned behaviour (TPB) in internet purchasing: using SEM", *International Conference on Marketing and Retailing, Petaling Jaya*, pp. 196-205.
- Karijin, B., Iris, V., Florence, B.B. and Wim, V. (2007), "Determinants of halal meat consumption in France", *British Food Journal*, Vol. 109 No. 5, pp. 367-86.
- Mark L. Brenson, David M. Levine, Timothy C. Krehbiel (2007). *Basic Business Statistics: Concepts and Applications*. 7th Ed., Pearson International.
- Marmaya, N. H., Zakaria, Z., & Mohd Desa, M. N. (2019). Gen Y consumers' intention to purchase halal food in Malaysia: a PLS-SEM approach. *Journal of Islamic Marketing*, 10(3), 1003-1014. <https://doi.org/10.1108/JIMA-08-2018-0136>
- Mohd. Majid Konting, (2000). *Kaedah Penyelidikan Pendidikan* (Ed. Ke-5). Dewan Bahasa dan Pustaka: Kuala Lumpur.
- Muhammad, N. M. N., Isa, F. M. and Kifli, B. C. (2009). "Positioning as Halal-Hub: Intergration Role of Supply Chain Strategy and Halal Assurance System", *Asian Social Science Journal*, 5(7)

- Pallant, H (2007). *SPSS Survival Manual: A step by Step Guide to Data Analysis using SPSS for Windows*. (3rd Ed.). Open University Press.
- Rezai, G., Mohamed, Z. A., Shamsudin, M. N., & Eddie Chew, F. C. (2009). Concerns for Halalness of Halal - labeled food products among Muslim consumers in Malaysia: Evaluations of selected demographic factors. *Economic and Technology Management Review*, vol. 4, 65-73.
- Sungkar, I. (2010). *Trends & Market Development of Halal Processed Food in Southeast Asia*.
- Vanany, Iwan, Soon, Mei, J., Maryani, Anny and Wibawa, & Mulia, B. (2019). Determinants of halal-food consumption in Indonesia. *Journal of Islamic Marketing*, 11(2), 507-521. <https://doi.org/10.1108/JIMA-09-2018-0179>

SERVICE QUALITY AND PILGRIMS' EXPERIENCE: A CASE OF AL' MAH'BUUB HAJJ AND UMRAH SERVICES IN OGUN STATE, NIGERIA.

SURAJUDEEN JOLAOSHO

Crescent University, Abeokuta

Abstract

Pilgrimage to Mecca remains one of the five pillars of Islamic theology with over 2 million faithfuls, from all over the world, gathering annually for the rituals. In such a situation, pockets of service failures are often inevitable arising from crowd management issues. There have been instances of delayed or cancelled flights for returning pilgrims or poor booking arrangement for accommodations reported in Nigeria. Despite these reports, research efforts have not examined service performance in the industry in Nigeria. It is against this backdrop that the present study examined the effect of service quality on customer satisfaction at Al' Mah'buub Hajj and Umrah Services, one of the approved private operators, with primary data obtained from 200 customers, selected randomly. The data were analysed using descriptive statistics and structural equation model for the SERVQUAL model conceptualised. The results revealed that majority (62%) were males with 83% between 31 and 50 years. Also all the customers had one form of formal education with 59% being married. In addition, half of the respondents were found to be in the low income bracket with the majority (95.5%) classified as basic customers. The study further revealed that reliability ($p < 0.01$), responsiveness ($p < 0.01$), assurance ($p < 0.01$), empathy ($p < 0.01$) and tangibles ($p < 0.01$) had positive and significant effects on customer satisfaction and thus concluded that service quality had positive and significant effect on pilgrims' satisfaction at Al' Mah'buub Hajj and Umrah services. The study therefore recommends that the organisation should maintain the positive customer experiences as shown by the five service quality dimensions.

Key words: Service Quality, Customers, Experience, Pilgrims

1.0 INTRODUCTION

Hajj is one of the five pillars of Islam (Reynold, 2015, Al'Hassan-Ewuoso, 2017) and one of the largest single gatherings of people on earth (Al'Hassan-Ewuoso, 2017)). It is compulsory for all Muslims who are financially and physically able. In the past, *Hajj* travelling was risky and involved difficulties such as limited transportation, infrastructure and accommodation and often took months or years to travel to the location. However, today's technology makes travelling for *Hajj*, from anywhere in the world, simple and easy. Every year between 2 and 3 million individuals gather for the exercise. For instance, the Royal Embassy of Saudi Arabia, reported that two million eighty-nine thousand and fifty-three pilgrims performed the hajj in 2014 while in 2017 about 2.4 million individuals were noted by Cochrane (2018) to have performed the *hajj* rites. Furthermore, the Mecca Chamber of Commerce and Industry reported that between 25%–30% of the private sector's income in the region spread around Mecca and Medina depends on pilgrimage. Record also has it that not less than ninety-five thousand Muslims from Nigeria participate in the exercise annually (NAHCON, 2017). The importance of *hajj* to Nigerians was further amplified by the commitment of 7.9 billion naira concession in the 2019 budgets to pilgrimage to Mecca and Jerusalem, a gesture that has witnessed serious criticisms, though Eleonu (2019) argued that outright cancellation of government sponsorship of pilgrims may produce negative results on the citizen's spirituality. The approved 2020 budget of NAHCON also attested to this fact as it stood at ₦1.1 billion and is expected to be fully covered by the commission, suggesting that hajj has ample capacity to generate substantial revenue for the government. In Nigeria, participation in *Hajj* involves a lot of activities and these include: obtaining an international passport valid for at least six with at least two empty visa pages; presentation of one recent passport-sized colour photograph; a duly completed application form endorsed by the authorized travel agency; a return ticket with confirmed reservations as well as evidence of vaccination for meningitis and yellow fever. The conduct of the Hajj and Um'rah services are handled by both Private and Public agencies in Nigeria. The Public agencies are the Muslim Pilgrims' Welfare Boards in each state while the Private agency is constituted by the Private Operators licensed by NAHCON. In 2019, about 15,950 seats were allotted to 115 private operators for hajj purposes (NAHCON, 2019). It has been observed over the years that pilgrims did experience untold hardships either physical or psychological in terms of outright disappointments, delayed or cancelled flights, poor accommodation,

inadequate feeding etc. (NAHCON, 2017) which call the service of both the Public and Private Operators to question and invariably the Pilgrims' satisfaction. These pockets of service failures are often inevitable arising from crowd management challenges.

While public operators may not be called to question because of the belief that decadence is inherent in public services in Nigeria, private operators cannot joke with poor service experience because of the available alternatives that can compel switching, more so that products and prices have become less important differentiators in the service industry (Ward and Dagger, 2007). In addition previous research efforts have not focused on customer satisfaction, despite the economical, political and spiritual benefits of *hajj* to Nigeria and Nigerians. From past literatures reviewed, emphasises have been on the historical, moral and ritual/spiritual aspects of *hajj* services in Nigeria. It is against this backdrop that the study focused on service quality as experienced by pilgrims who patronised Al' Mahbuub with additional benefits of assisting the service providers of *hajj*, especially the case study, to identify service quality dimensions that most predict customers' satisfaction, in order to concentrate on them with the consequences of enjoying repeat patronage; avert undue switching; earning higher profit and greater reputation. The study is also helpful to policy makers, including the regulatory authority such as NAHCON on what to look for when reviewing the performance of *hajj* by Operators and other service providers. To accomplish these outcomes, the study specifically examined the various service quality dimension as perceived by clients of Al' Mahbuub Hajj and Um'rah Services Nigeria Limited and the effect they have on customer satisfaction. It also examined the socio-demographic characteristics of the respondents with a view to understanding their behaviour better.

2.0 BRIEF REVIEW OF LITERATURE

Service quality according to Davoudian (2010) enables companies to distinguish themselves from competitors, attain sustainable competitive advantage, and improve their functionality. This is further affirmed by (Abdullah, Suhaimi, Saban and Hamali, 2011) that service quality is one of the most effective means of establishing a competitive position and improving profits of a firm. Wong and Sohal (2003) also affirmed that one of the provisions of high quality service remains an effective strategy to keep the customer loyal with a service organisation.

Service quality today therefore, has become not only the rhetoric of every business enterprise, but also an important concept in service research. It is virtually impossible for a business organisation to survive without building customer satisfaction and loyalty (Agbemabiese, Patrick and Nii Tetteh Nyanyofio, 2015). Research has shown repeatedly that, service quality influences organisational outcome such as performance superiority (Portek and Thanassoulis, 2005) increasing sales and profits (Kish, 2000; Duncan and Elliot, 2002) and market share (Fisher, 2001), improves customer relations, enhance corporate image and promote customer loyalty (Newman, 2001; Caruana, 2002; Ehigie, 2006).

No business organisation can survive without building its customer satisfaction and brand loyalty and by extension; no organisation can make a healthy living without meeting the needs of its customers. That is what organisations do: they serve people's needs. Service quality helps in cementing the relationship between customers and the organisation and it is a two-way flow of values. This means that customer derives real value from the relationship which translates into value for the organisation in the form of enhanced profitability and sustainability over a long period of time (Ojo, 2010).

However, having satisfied customers does not only hold the potential of increasing an organisation's customer base, but also increases the use of more volatile customer mix and increase the firm's reputation (Alabar, 2012). According to Zeithaml (2000), Manusamy, Chellia and Mun (2010), delivering high quality services are closely linked to profits, cost savings and market share. Since survival and growth of a firm's outcome is driven by customer loyalty, which in turn is driven by customer satisfaction and value, delivering quality service and customer satisfaction have remained important goals and most perhaps, the pursuit for organizations. (Nimako, 2012; Rust and Oliver, 1994). Turel and Serenko (2006), affirms that customer satisfaction measurement addresses both users' and public interests and such studies can assist in economic and social development.

Whether an organization provides quality services or not depends on customers' feedback on the satisfaction they get from consuming the products or experiencing the service, since higher levels of quality lead to higher levels of customer satisfaction (Kotler and Keller, 2009). Hence, to achieve high level of customer satisfaction in Hajj operation, an understanding of service qualities that drives satisfaction is a must.

Parasuraman, Zeithaml and Berry (1985) identified 10 requirements useful for customers' evaluation of the quality of services. These factors include reliability, responsiveness, tangibles, communication, credibility, security, competence, courtesy, understanding the customers and service accessibility. The researchers proposed a service quality scale called (SERVQUAL), the scale is a generic instrument that has five dimensions of service quality: reliability, responsiveness, assurance, empathy and tangibles. These five dimensions were used in this study to determine the quality of service provided by Al'Mahbuub Hajj and Umrah Services.

3.0 METHODOLOGY

The study focused on assessing service quality on customer satisfaction as experienced by the individuals and organisations that patronize Al' Mah'buub Hajj Operator in the last four years. Simple random sampling was used to select two hundred (200) out of the 440 clients on the sample frame and copies of structured questionnaires, divided into three sections (demographics, service quality and customer satisfaction) were administered. Demographic information sought included gender, age, marital status, occupation and level of income while service quality was captured by the five SERVQUAL dimensions of reliability, responsiveness, assurance, empathy and tangibles. On the other hand, customer satisfaction was operationalised with the disconfirmation scale. This scale was considered appropriate for three reasons. The first was that it incorporated the well-known disconfirmation paradigm into the customer satisfaction setting (Cadotte and Turgeon, 1988), thus compressing the scale of Parasuraman's (1988) two-stage SERVQUAL measurement of both expectation and perception into one succinct question. Hence, a respondent simply rated the service with respect to their own expectations. The second attractive feature of the scale is the fact that it can be shown mathematically that comparison with expectations zealous would correlate higher with customer retention than either a quality question or a satisfaction question as observed by Rust, Zahorik and Keiningham (1994). The last compelling feature of the disconfirmation scale was that it could drastically reduce the asymmetry in the measured perceived service. This was because not all customers who rate the service highly, for example, as good or excellent on a poor to excellent scale, would also say they perceive the service as "better than expected". The study validated these measurement scales by examining the convergent and discriminant validity. Convergent validity was the extent of agreement among scales measuring the same while discriminant validity looked at the disagreement among scales used to measure concepts that were not expected to be related. Cronbach's alpha was used to assess the reliability of measurement scales with multi-point items relating to the components of a service process. Based on this, the Cronbach alpha test with the value of $\alpha \geq 0.7$ was considered threshold for reliability.

Table 1: Measurement of Variables

Variables	Measurement
Service quality	SERVQUAL 5 dimension scale of reliability, responsiveness, assurance, empathy and tangibles.
Customer satisfaction	Overall satisfaction, expectation and overall quality.

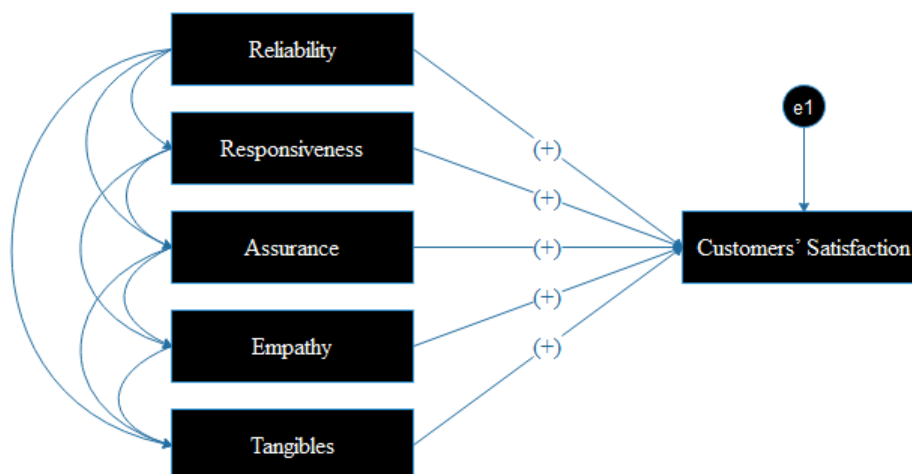

Figure 1: Hypothesised Diagram of Service Quality and Customers' Satisfaction.

4.0 RESULTS AND DISCUSSION

Socio-Demographic Characteristics of Pilgrims

The study revealed that are more males (62%) than females (table 2) that have performed Hajj with Al' Mahbuub Hajj and Umrah Services. This may not be unconnected with the facts that women are always at the homefront catering for the family coupled with the need to uphold the Islamic injunction that discourages women from travelling without their "mahram" (a rightful guide). With respect to age, 10.5% of them were between 21-30 years, 41% were between 31-40 years, 42% were between 41-50 years while 6.5% were above 50 years. Though age is never a barrier to performing Hajj as long as one has attained puberty as defined by the Islamic doctrine and physically and mentally fit, many (83%) of those who patronised the operator for pilgrimage are between the ages of 31 and 50 years. This may also not be unconnected with the reality that Hajj requires not only financial resources but equally the physical wellbeing for one to embark on it. Of the sampled respondents, majority (59.5%) of them were married, which may not be unconnected with the fact that having a Mahram (husband or a person whom a woman cannot marry) is among the conditions that make Hajj obligatory upon a woman and she may not travel without him. The study also revealed that all the respondents have one form of formal education which implied that they could either read or write thus suggesting ease of service because they would be able to read instructions especially when completing documents. The study further revealed that 49.5% belong to lower income level, 40.5% belonged to the middle income level while 10% belong to the upper income level. The distribution on the income levels seemed unrealisable as one expect the bulk of those patronising private Hajj operators to be in the upper income bracket and very few in the middle and perhaps none in the lower level, because the private operator usually charge a premium above that of the public operators and this may not be within the reach of many low and middle income earners.. However, the possible explanation is the fact that many could have been sponsored by well to-do individuals or organisations or sometimes they build their savings as the organisation has schemes that allow potential pilgrims to pay on instalments. This position is corroborated by the fact that only 4.5% of those that patronised the organisation chose the VIP option because of its cost implication.

Table 2: Socio-demographic characteristics of Respondents

Characteristics		Frequency	Percentages
Sex	Male	124	62.0
	Female	76	38.0
Total		200	100
Age (Years)	≤20	0	0.0
	21 – 30	21	10.5
	31 – 40	82	41.0
	41 – 50	84	42.0
	> 50	13	6.5
Total		200	100
Marital Status	Single	31	15.5
	Married	118	59.0
	Divorced	23	11.5
	Widow/ Widower	28	14.0
Total		200	100
Highest Educational Qualification	Primary	23	11.5
	Secondary	47	23.5
	NCE/OND	59	29.5
	HND/B.Sc.	69	34.5
	M.Sc./Ph.D.	2	1.0
Total		200	100
Income Level	Lower (₦1,300,000)	99	49.5
	Middle (₦1,650,000)	81	40.5
	Upper (₦1.8 to ₦2 million)	20	10.0
Total		200	100
Category of Customer	Basic	191	95.5
	VIP	9	4.5
Total		200	100

Source: Field Survey, 2018

4.1 Pilgrims' Satisfaction

The responses of pilgrims to elicit information about their experiences with a view to knowing if they were satisfied or not with the services of Al'Mah'buub Hajj and Umrah services are presented in appendix C. Results showed that 50.5% of the pilgrims strongly agreed that they were satisfied with the services of Al'Mah'buub Hajj and Umrah services, 33% agreed, 12.5% could not decide, 5.5% disagreed while 7% strongly disagreed. Therefore, majority (83.5%) of the respondents agreed with the statement. The survey to know if pilgrims would choose to stay with Hajj and Umrah service ahead of others, showed that 24.5% of the pilgrims strongly agreed, 42.5%

agreed, 14% results could not decide, 10.5% disagreed while 7.5% strongly disagreed. Therefore, majority (68%) of the respondents agreed with the statement. Similarly, an attempt to know whether pilgrims always felt good about the performance of the services of the operator before and after the pilgrimage exercise, result showed that 39% of the pilgrims strongly agreed, 35.5% of them agreed, 4% could not decide, 15.5% disagreed while 6% of them strongly disagreed. Hence, the study concluded that majority (64.5%) of the pilgrims are satisfied with their experience of the services rendered by the operator, pre and post *hajj* conducts. Efforts to elicit information on the repeat purchase intention of the the pilgrims for the Operator lead to an inquiry know whether pilgrims would be proud to recommend Al'Mah'buub to any intending pilgrim. The result showed that 20.5% of the pilgrims strongly agreed, 45% of them agreed, 7% could not decide, 18% disagreed while 8.5% of them strongly disagreed. Therefore, the study opined that since majority (65.5%) of the respondents agreed with the statement, the pilgrims are willing to recommend the Operators to intending individuals and organisation who wished to perform *hajj* in subsequent years.

4.2 Results of the Path Analysis of the hypothesised model

In order to estimate the path model hypothesised for the study, the factor score of the six constructs were generated which made each construct to be treated as an observed variable and used for the analysis. As shown in Table 4, the Cronbach's alpha values of the measured variables ranged from 0.71 to 0.88, which indicate acceptable reliability for the measurement instruments used in the study. The estimated model was evaluated for goodness of fit as presented table 5. The table reported the Standardized Root Mean Square Residual (SRMR), the Comparative Fit Index (CFI), the Root Mean Square Error of Approximation (RMSEA), and 90% confidence limits for the RMSEA (RMSEA CL90). Values for the CFI greater than 0.94 suggest good fit for data fitted to the path models (Hu and Bentler 1999), whereas SRMR and RMSEA must have values less than 0.090 and 0.055 respectively to suggest an acceptable fit for a good model (McDonald and Ho 2002). Ideally, the full 90% range for the RMSEA was unacceptable to ideal limits (Byrne 2009; McDonald and Ho 2002). Results from table 4 indicated that all goodness-of-fit indices were within ideal parameters as CFI = 0.95, SRMR = 0.065, and RMSEA = 0.057.

Table 4: Result of Reliability Test

Construct	Number of items	Number of cases	Cronbach's Alpha
Customer service	4	200	0.74
Responsiveness	4	200	0.71
Assurance	4	200	0.81
Empathy	4	200	0.83
Tangibles	4	200	0.77
Pilgrims' Satisfaction Construct	4	200	0.88
Customer satisfaction			

Source: Computed Field Survey, 2018

Table 5: Goodness-of-Fit Indices

Model	χ^2	df	CFI	SRMR	RMSEA
Initial model	37.39	4	0.95	0.065	0.057

Source: Field Survey, 2018

Note: χ^2 = chi-square; df = degrees of freedom; CFI = Comparative Fit Index; SRMR = Standardized Root Mean Square Residual; RMSEA = Root Mean Square Error of Approximation.

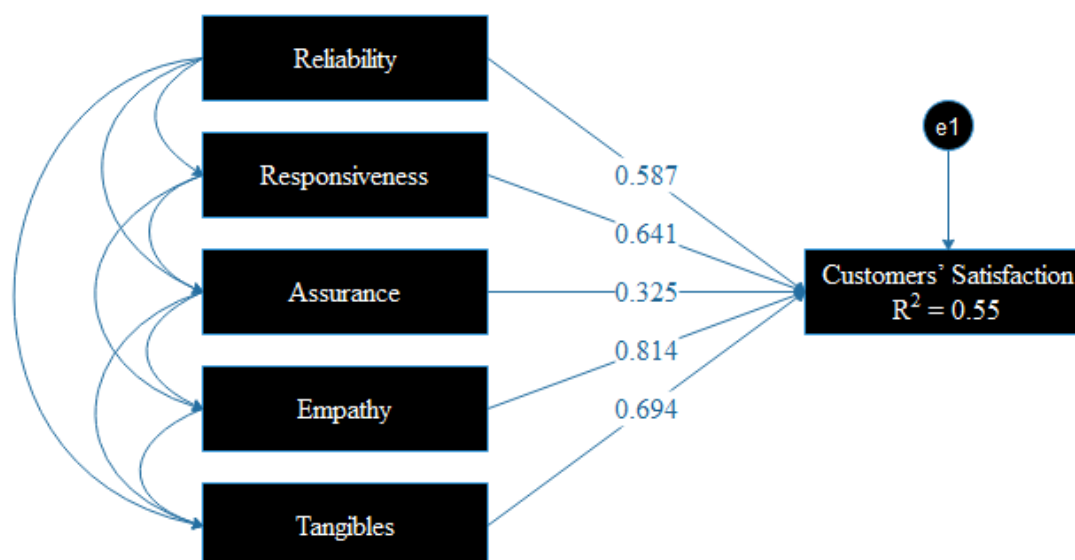

Figure 2: Path Diagram of the estimated model of Service Quality and Satisfaction

4.2.1 Customers' Satisfaction

The parameter of the path model estimated to assess the viability of the theoretical model testing dimensions of the SERVQUAL of Parasuraman *et al.* (1988) as it affects pilgrims' satisfaction at Al'Mah'buub Hajj and Umrah services are presented in table 6. The model was estimated using IBM-AMOS Version 24 (maximum likelihood method of parameter estimation) based on the variance-covariance matrix. The data fit well with the hypothesized model that reliability, responsiveness, assurance, empathy and tangibles would each significantly predict customers' satisfaction. The five exogenous variables were all assumed to be correlated. The estimated path coefficients in the model differed significantly from zero, χ^2 (4, N = 200) = 37.39, $p < 0.01$. Squared multiple correlation value for pilgrims' satisfaction ($R^2 = 0.55$) indicated that predictor variables captured a substantial percentages of observed variance (55%) for the dependent variables. In line with the *a priori* expectation, the standardized path coefficient from reliability ($\beta = 0.587$, $p < 0.01$); responsiveness ($\beta = 0.641$, $p < 0.01$); assurance ($\beta = 0.325$, $p < 0.01$); empathy ($\beta = 0.814$, $p < 0.01$) and tangibles dimensions ($\beta = 0.694$, $p < 0.01$) to the pilgrims' satisfaction are each proved to be statistically and positively significant.

Table 6: Model Estimates

Proposed Paths	Estimates	T-Statistics	Probability Value
Reliability → Customers satisfaction	0.587	5.54	0.01
Responsiveness → Customer satisfaction	0.641	6.03	0.01
Assurance → Customer satisfaction	0.325	11.23	0.01
Empathy → Customer satisfaction	0.814	7.89	0.01
Tangibles → Customer satisfaction	0.694	9.68	0.01

Source: Field Survey, 2018

5.0 CONCLUSION, IMPLICATIONS AND RECOMMENDATIONS

Overall, the study opined that pilgrims' experiences are substantially explained by the five dimensions of reliability, responsiveness, assurance, empathy and tangibles. And that these dimensions positively influenced the satisfaction experienced by them at Al'Mah'buub Hajj and Umrah services. The study therefore lent its voice to previous studies () that have established positive and significant relationships of the dimensions in SEVQUAL to customer experience denoted by satisfaction. The study therefore draws implications for service quality managers in the studied *hajj* Operator and others in the industry by focusing on the various items considered in the scale of measurements as the determinants of current and future patronage, business growth and competing strength. Policy makers and industry evaluators are also to learn the lesson of knowing what to include in their scale of rating for performance assessment. Al'Mah'buub Hajj and Umrah services should, specifically ensure that they keep their

physical facilities and equipment up-to-date to handle customer's requests; promote individualised and prompt attention to customers as this has been found to instil confidence and trust in them; ensure that staff are continually trained to handle customer's complaints as fast as possible, especially those in the front office function or customer facing. The organisation should also ensure that they did not renege on the promises made to customers before and after patronage continue to welcome new ideas and suggestions that can move the organisation towards international standard practices.

REFERENCES

- Abdullah, F., Suhaimi, R., Saban, G. and Hamali, J. (2011). Bank Service Quality (BSQ) Index: An indicator of service performance. *International Journal of Quality and Reliability Management*, 28(5), 542-555.
- Agbemabiese, G. C., Patrick, A. A. and Nii Tetteh Nyanyofo, G. J. (2015). Service quality and customer satisfaction in the Ghanaian banking industry (A case of Ghana commercial bank). *European Journal of Business and Management*, 7(3), 123-140.
- Alabar, T. T. (2012). Electronic banking services and customer satisfaction in the Nigerian banking industry. *International Journal of Business and Management Tomorrow*, 2(3), 1-8.
- Cadotte, E. R. and Turgeon, N. (1988). Key factors in guest satisfaction. *The Cornell Hotel and Restaurant Association Quarterly*, 41-51.
- Caruana, A. (2002). Service loyalty: The effects of service quality and the mediating role of customer satisfaction. *European Journal of Marketing*, 36(7/8), 811 - 828.
- Cochrane, Paul (2018). The economics of hajj. Accounting and Business magazine 1st July, 2018. accglobal.com/an/en/member/member/accountingbusiness/2018/07/insights/economics-hajj.html. Accessed 28th August, 2020.
- Davoudian, F. (2010). Survey customers' satisfaction of Refah Bank and its relationship with quality of bank services. Unpublished Master Thesis, Sanandaj Islamic Azad University.
- Duncan, E. and Elliot, G. (2002). Customer service quality and financial performance among Australian retail financial institutions. *Journal of Financial Services Marketing*, 7(1), 25 - 41.
- Ehigie, B. O. (2006). Correlates of customer loyalty to their bank: A case study in Nigeria. *International Journal of Bank Marketing*, 24(7), 494 - 508.
- Fisher, A. (2001). Winning the battle for customers. *Journal of Financial Services Marketing*, 6(2), 77-83
- Jonathan Reynolds (2015). Stealing the Road: Colonial rule and the hajj from Nigeria in the early twentieth century. *Journal of West African History*, Vol. 1, Iss. 2, 27-44. ISSN 2327-1868. doi. 102.89.3.23 accessed on Mon, 24 August 2020 11:02:06
- Kish, J. (2000). Before your customers leave. *Bank Marketing*, 32(2), 30.
- Kotler, P. and Keller, K. L. (2009). *Marketing Management (13th ed.)*. New Jersey: Pearson Education Inc., Upper Saddle River.
- Manusamy, J., Chellia, S. and Mun, H. W. (2010). Service quality delivery and its impact on customer satisfaction in the banking sector in Malaysia. *International Journal of Innovation, Management and Technology*, 1(4), 398-404.
- NAHCON (2017). Policies and guidelines. Retrieved from <https://nigeriahajj.com.gov.ng>
- NAHCON (2019). News. nigeriahajj.com.gov.ng/2019/10/25/nahcons-2020-budgetpresentation.
- Newman, K. (2001). Interrogating SERVQUAL: A critical assessment of service quality measurement in a high street retail bank. *International Journal of Bank Marketing*, 19(3), 126 - 139.
- Nimako, S. G. (2012). Linking quality satisfaction and behaviour intentions in Ghana's mobile telecommunication industry. *European Journal of Business and Management*, 4(7), 1-18.
- Ojo, O. (2010). The relationship between service quality and customer satisfaction in the telecommunication industry: Evidence from Nigeria. *Broad Research in Accounting, Negotiation, and Distribution*, 1(1), 88-100.
- Parasuraman, A., Zeithaml, V. A. and Berry, L. L. (1985). A conceptual model of service quality and its implications for the future research. *Journal of Marketing*, 49, 41-50.
- Portela, M. and Thanassoulis, E. (2005). Profitability of a sample of Portuguese bank branches and its decomposition into technical and allocative components. *European Journal of Operational Research*, 162(3), 850-866.
- Royal Embassy of Saudi Arabia Net. (2015). Number of Hajj Arrivals. Retrieved 28 August, 2017, from http://www.saudiembassy.net/latest_news/news10131302.aspx
- Rust, R. T. and Oliver, R. L. (1995). Service quality: Insights and management implications from the frontier. In Rust, R., and Oliver, R. R. (eds.), *Service Quality: New Directions in Theory and Practice*, Sage Publications, Thousand Oaks, CA, pp. 1-20.
- Rust, R. T. and Zahorik, A. J., and Keiningham, T. L. (1994). *Return on Quality*, Probus Publishing, Chicago, IL.
- Turel, O. and Serenko, A. (2006). Satisfaction with mobile services in Canada: An empirical investigation. *Telecommunications Policy*, 30, 314-331.
- Ward, T. and Dagger, S. T. (2007). The complexity of relationship marketing for service customers. *Journal of Services Marketing*, 21(4), 281 - 290.
- Wong, A. and Sohal, A. (2003). Service quality and customer loyalty perspectives on two levels of retail relationships. *Journal of Services Marketing*, 17(5), 495-513.
- Zeithaml, V. A. (2002). Service quality and economic worth of customers: What we know and what we need to learn. *Journal of the Academy of Marketing Science*, 28(1), 67-85.

Appendix A

Distribution of Respondents by Reliability and Tangible Factors

Scale items for Reliability Factor		Frequency	Percentages(%)
At Al'Mah'buub, services are delivered promptly as promised.	Strongly disagree	10	5.0
	Disagree	22	11.0
	Neutral	03	1.5
	Agree	43	21.5
	Strongly agree	122	61.0
Solving customers' complaints at Al'Mah'buub is consistent and with maturity.	Strongly disagree	04	2.0
	Disagree	09	4.5
	Neutral	0	0.0
	Agree	33	16.5
	Strongly agree	154	77.0
Services delivery in terms of flight schedule and accommodation are timely.	Strongly disagree	02	1.0
	Disagree	27	13.5
	Neutral	21	10.5
	Agree	51	25.5
	Strongly agree	99	49.5
Al'Mah'buub Hajj and Umrah services insists on error-free records of pilgrims.	Strongly disagree	09	4.5
	Disagree	11	5.5
	Neutral	0	0.0
	Agree	63	31.5
	Strongly agree	117	58.5
Scale Items for Tangible Factor			
Al' Ma'buub staff appear neat and well dressed.	Strongly disagree	19	9.5
	Disagree	20	10.0
	Neutral	42	21.0
	Agree	71	35.5
	Strongly agree	48	24.0
Materials like pamphlet, flyers that are associated with Al'Mah'buub services are visually appealing.	Strongly disagree	12	6.0
	Disagree	04	2.0
	Neutral	0	0.0
	Agree	41	20.5
	Strongly agree	143	71.5
Customer service desk of the company is well equipped with up – to – date equipment.	Strongly disagree	02	1.0
	Disagree	12	6.0
	Neutral	62	31.0
	Agree	55	27.5
	Strongly agree	69	34.5
Al' Mah'buub's office environment displays high aesthetic value.	Strongly disagree	24	12.0
	Disagree	33	16.5
	Neutral	18	9.0
	Agree	67	33.5
	Strongly agree	58	29.0

Appendix B**Distribution of Respondents Responsiveness and Empathy Factors**

Scale items for Responsiveness Factors		Frequency	Percentages
Al' Mah'buub Hajj and Umrah services tells pilgrims the exactly date they will be travelling to Mecca.	Strongly disagree	07	3.5
	Disagree	21	10.5
	Neutral	11	5.5
	Agree	67	33.5
	Strongly agree	94	47.0
Pilgrims receive prompt services from Al' Mah'buub Hajj and Umrah services.	Strongly disagree	0	0.0
	Disagree	06	3.0
	Neutral	20	10.0
	Agree	59	29.5
	Strongly agree	115	57.5
	Strongly disagree	18	9.0
	Disagree	22	11.0
	Neutral	10	5.0
Staff of Al' Mah'buub Hajj and Umrah services are always willing to help pilgrims.	Agree	61	30.5
	Strongly agree	89	44.5
	Strongly disagree	18	9.0
	Disagree	31	15.5
Staff of Al' Mah'buub Hajj and Umrah services are never too busy to respond to pilgrims' request.	Neutral	0	0.0
	Agree	19	9.5
	Strongly agree	132	66.0
	Strongly disagree	18	9.0
Scale Items for Empathy Factors			
Al' Mah'buub Hajj and Umrah services give pilgrims individual attention.	Strongly disagree	06	3.0
	Disagree	17	8.5
	Neutral	10	5.0
	Agree	78	39.0
	Strongly agree	89	44.5
Al' Mah'buub Hajj and Umrah services have operating hours is convenient to pilgrims.	Strongly disagree	12	6.0
	Disagree	27	13.5
	Neutral	5	2.5
	Agree	99	49.5
	Strongly agree	57	28.5
Al' Mah'buub Hajj and Umrah services has pilgrims best interest at heart.	Strongly disagree	36	18.0
	Disagree	28	14.0
	Neutral	13	6.5
	Agree	46	23.0
	Strongly agree	77	38.5
Al' Mah'buub Hajj and Umrah services understands pilgrims specific need.	Strongly disagree	25	12.5
	Disagree	26	13.0
	Neutral	41	20.5
	Agree	48	24.0
	Strongly agree	60	30.0

Appendix C
Distribution of Respondents by Assurance and Satisfaction Factors

Scale Items for Assurance Factors		Frequency	Percentages
I feel safe when conducting business with Al'Mah'buub.	Strongly disagree	0	0.0
	Disagree	0	0.0
	Neutral	0	0.0
	Agree	99	49.5
	Strongly agree	101	50.5
I can trust the staff of Al'Mah'buub for prompt delivery of services.	Strongly disagree	0	0.0
	Disagree	0	0.0
	Neutral	33	16.5
	Agree	100	50.0
	Strongly agree	67	33.5
The conduct of Al'Ma'buub staff instills confidence in me.	Strongly disagree	0	0.0
	Disagree	0	0.0
	Neutral	0	0.0
	Agree	43	21.5
	Strongly agree	157	78.5
Al'Mah'buub staff are always available to solve my problem satisfactorily.	Strongly disagree	33	16.5
	Disagree	17	8.5
	Neutral	19	9.5
	Agree	55	27.5
	Strongly agree	76	38.0
Scale Items for Satisfaction			
Overall, I am satisfied with Al'Mah'buub Hajj and Umrah services.	Strongly disagree	14	7.0
	Disagree	11	5.5
	Neutral	25	12.5
	Agree	84	33.0
	Strongly agree	66	50.5
If another Hajj and Umrah service provider come to Abeokuta, I will choose to stay with Al'Mah'buub Hajj and Umrah services.	Strongly disagree	15	7.5
	Disagree	21	10.5
	Neutral	28	14.0
	Agree	87	43.5
	Strongly agree	49	24.5
I always feel good about the performance of Al'Mah'buub Hajj and Umrah services before and after the performance of pilgrimage.	Strongly disagree	12	6.0
	Disagree	31	15.5
	Neutral	8	4.0
	Agree	71	35.5
	Strongly agree	78	39.0
I am proud to recommend Al'Mah'buub to any intending pilgrim.	Strongly disagree	17	8.5
	Disagree	36	18.0
	Neutral	14	7.0
	Agree	92	46.0
	Strongly agree	41	20.5

THE LEGAL CONCEPT OF CORPORATION UNDER COMMON LAW AND SHARIAH: AN APPRAISAL

Zuhairah Ariff Abd Ghadas, Hartinie Abd Aziz & Nazri Ramli

Faculty of Law and International Relations, Universiti Sultan Zainal Abidin, Terengganu, Malaysia

Abstract

Under the company law, a corporation is a juristic person and upon its incorporation, it has a separate legal entity being distinct from its incorporators. Distinguishably, under Shariah, the concept of corporation is basically non-existent. In particular, the concept of juristic person is not directly dealt with by the Muslim jurists. Nonetheless, the contemporary Muslim jurists make the effort to discuss it under the purview of Shariah by looking at classical Fiqh institutions, as well as business entities such as *musharakah*; which is viewed as the closest form of business organization to corporation.

This paper discusses both the legal concept of corporation under the common law which justify the existence of conventional companies and the legal concept of corporation under Shariah with special reference to *musharakah*. The discussion is important since many discussions have attempted to equate both business entities equally which may lead to confusing outcomes. This article adopts the doctrinal analysis research methodology. Findings of this article recommends an inculcation of Shariah principles of *musharakah* into the conventional corporation as an initiative to produce a Shariah-compliant corporation in Malaysia.

Keywords: Corporation, *Sharikah*, Common Law, Shariah

1.0 INTRODUCTION

The concept of corporation had been widely used in common law countries as well in Islamic countries. According to Inran, the modern world is structured around the concept of the corporation. Wherever we turn, we either find a corporation aggregate or a corporation sole at the top of the structure. It is a device that has enabled human beings to avoid huge transaction costs⁷¹. Some people argue for the need to protect *maslahah* for the entrepreneur and third party because in business corporation it is not only combined with the concept of limited liability, but it is also a device for raising large sums of capital for which, it cannot be done by using conventional partnership⁷². Scholars have argued the legality of a corporation in Islam. The paramount issue to be examined is whether a corporation is recognised under the Islamic law. Some Muslim argues that the concept of corporation is recognised under Islamic law since ages, and therefore, the concept of corporation that is applied in the common law country does not contradict with any shariah requirement as mentioned by Hafeez:

*“A company is a species of corporation and has a dual nature as both an association of its members and legal or artificial person which is quite distinct from its members. The concept of a company does not appear to be against the Injunctions of Islam. The formation and incorporation of a company under any legislative procedure of the state has a legal status of artificial person having legal entity rather a natural person with some rights and obligations”*⁷³.

While some of Muslim do not recognise the concept of corporation and consequently argue that, this concept is contradicting with the norms of Shariah. This paper analyse the legal concept of corporation under the common law and Shariah to examine whether the concept of corporation in Islam is similar with what have been practiced under the common law. Special reference are made to the Kingdom Saudi Arabia as an Islamic country which practices the concept of corporation.

⁷¹ Nyazee, *Islamic Law of Business Organization: Corporation* (n 8).

⁷² Mervyn K Lewis, ‘Islamic Corporate Governance’ (2005) 9 *Review of Islamic Economics* 5.

⁷³ Malik M. Hafeez, ‘An Analysis of Corporate Entity and Limited Liability in Islamic and Western Perspectives of Corporate Governance’ (2013) 2 *International Journal of Business, Economics and Law*, 104. See also. ‘Alī Muḥyī al-Dīn Raḡhī, “al-Aswāq al-Mīyah,” *Majallat Majma’ al-Fiqh al-Islām* 7:1 (1992) 85. According to some scholars, the business corporation does not violate any principles of the shari‘ah, nor is there any clash with the rules of fiqh.

2.0 THE CONCEPT OF CORPORATION

2.1 Common Law

Under the common law, corporation is defined as a group of persons who are deemed in law to be a single legal entity. The corporate entity is legally distinct from its members; it has legal personality and can hold property, sue and being sued in its own name as if it were a natural person⁷⁴. While, according to Keenan and Bisacre as noted in Zuryati, 'A corporation is a succession or collection of persons having at law an existence, rights and duties, separate and distinct from those of the persons who are from time to time its members'⁷⁵. In other words, corporation can be defined as a company having a status as a body corporate and carries few features and attributes. As noted by Endalew, Gogna defines a company as "a voluntary association of persons formed to achieve some common objectives, having a separate legal entity, independent and separate from its members, with a perpetual succession and a common seal, and with capital divisible into transferable shares"⁷⁶. The term 'Corporation' is commonly used in the common law legal system though it is broader in concept which includes public enterprises⁷⁷. Imran quoted the definition of corporation as defined by Guthman and Dougal "the formation of an association of persons into an autonomous legal unit with a distinct legal personality that enables it to carry on business, own property and contract debts through its agents and officers"⁷⁸. While, Lindley says: "A corporation is an artificial person created by special authority (by the law of England, by the Crown, or by Parliament) and endowed by that authority with a capacity to acquire rights and incur obligations"⁷⁹.

In England, the concept of corporation was first established in the sixteenth century. In 1670 the East India Company and the Hudson Bay Company, were incorporated as "joint stock companies." The word *stock* at that time meant the stock of goods delivered by the shareholder or member. This stock was considered to be the share of the shareholder for purposes of sharing the profit. The word joint stock meant the capital of the company⁸⁰. The South Sea Company was established on 8 September 1711 by a charter, authorised by act of Parliament as a joint-stock company which incorporated "the Governor and Company of the merchants of Great Britain, trading to the South Seas and other parts of America, and for the encouragement of fishing". It was created as a public-private partnership to consolidate and reduce the cost of national debt. However, the creation of this floating company led to financial disasters like the one of the "Bubble Companies," that would appear one day and disappear the next⁸¹. The Bubble Act 1720 (6 Geo I, c 18), was created by the parliament to remedy the deception of investors by prohibiting the creation of joint-stock companies without royal charter, was initially promoted by the South Sea company itself before its collapse. However, this particular Act provided the benefits of the South Sea Company in competition with the Bank of England but this company failed and its shares decreased ridiculously⁸².

The codification of Companies Act only begins in 1844 with the enactment of the Joint Stock Companies Act, (7 & 8 Vict. c. 110 & 111). The Joint Stock Companies Act 1844 was enacted- and stipulates that any company comprising more than twenty-five members with transferable shares might obtain incorporation by registering a deed of settlement executed by its members. Secondly, the Limited Liability Act 1855 was passed which provided limited liability of the members of a company. The act was repealed by the Joint Stock Companies Act 1856 that allowed incorporation of the companies with limited liability and introduced the memorandum and articles of association by omitting the provisional registration and deed of settlement. Between 1862 to 1907, a number of laws were passed that permitted the alteration of capital, the amendment of the memorandum and articles, as well as registration of private Companies.

The Companies Consolidation Act 1908 gathered all the previous laws into a single Act. The amendment of the law continued till the Act of 1907. In India, the company laws were introduced in 1850. This was followed by changes in 1857, 1866, 1887 till the law of 1913 which based upon the English Law of 1908. Changes made in this law in 1946 and these were based upon changes in the law of England. However, the new Companies Act 1985 was introduced on the basis of previous statutory developments. The Directors' Liability Act of 1890 created the directors' liability to compensate all shareholders for damages suffered due to their untrue statements. The Insolvency Acts (1986, 1994 and 2000), the Company Directors Disqualification Act 1986, and the Enterprise Act

⁷⁴ Collins Dictionary of Law. (2006). Retrieved August 26 2017 from <http://legal-dictionary.thefreedictionary.com/corporation>

⁷⁵ Zainal a Zuryati, Ahmad N Azrae and Mohamed Yusoff, 'Separate Legal Entity under Syariah Law and Its Application on Islamic Banking in Malaysia: A Note' (2009) 6 The International Journal of Banking and Finance 139.

⁷⁶ Endalew Lijalem Enyew, 'The Doctrine of Piercing the Corporate Veil: Its Legal and Judicial Recognition in Ethiopia' (2012) Vol. 6 Mizan Law Review.

⁷⁷ Enyew (n 26).

⁷⁸ Nyazee, *Islamic Law of Business Organization: Corporation*.

⁷⁹ Earnest H Lindley Schamell, *The Law of Partnership*. (12th edn, Sweet and Maxwell 1962).

⁸⁰ Nyazee, *Islamic Law of Business Organization: Corporation*.

⁸¹ Nyazee, *Islamic Law of Business Organization: Corporation*.

⁸² Malik M Hafeez, 'Evolution of Corporate Entity in Islamic and Western Perspective' (2013) 2 77.

2002 also enacted to govern the insolvency, winding up and directors' disqualification proceedings. The present UK Companies Act was enacted in 2006 to replace the Companies Act 1985.

2.2 Shariah

Shariah recognizes a wide range of business structures for the purpose of trading, investment, and profit-making. The most common structures are *sharikah/shirkah* or *musharakah*. This structure has been frequently construed as similar, or at least equivalent, to what is contemporarily termed as *partnership*. Nonetheless, the term *sharikah* or *musharakah* actually connotes a wider meaning than that of normal partnership⁸³. The term may include not only the modern partnership structure, but also any other structure that involves capital contribution and the subsequent profit and loss-sharing, including that of shareholding in modern companies, and even, certain parts of financing arrangement in a joint venture. All business transaction in Islam used a contract as the basis of relationship between the parties and thus, there is no concept of corporation as practiced by the common law. As mentioned by Nicholas Foster, "the shariah did not have corporations, only partnerships, which had neither legal personality nor limited liability"⁸⁴. However certain Islamic jurist recognized the corporation in Islamic law by saying that a corporation is a contract. The main issue to be examined is whether a corporation is a contract, and what kind of contract used in the corporation.

In countries which applied Shariah as the law of the country, such as Kingdom of Saudi Arabia (KSA), corporation is referred as the different types of *Sharikah* (partnership) having a status as a legal person. Corporation is treated as entity depending on the agreement. The term corporation used intermingle to refer to types of partnership (*musharakah*)⁸⁵. An example of the application of *sharikah* as corporation can be seen in Saudi Arabia which applies *Shariah* as the law of the country whereby under the laws of Saudi Arabia the term *sharikah* is include partnerships and corporations⁸⁶. According to Chapra, partnership in an Islamic society may take one of two juristic forms, *mudharabah* or *sharikah*⁸⁷. *Mudharabah* is a contract between the *sahibul mal* (financier or investor) and *al-mudharib* (entrepreneur) where the entrepreneur will run the business while the financier will invest the money with an agreed portion of profit sharing. The *sahibul mal* (financier or investor) finances the *mudharib's* (entrepreneur's) business not in the capacity of a lender but as an investor. He is the owner of the business, and shares the risk of the business to the extent of his share in the total financing of the business. The entrepreneur manages the investment funds placed at his disposal by the financier in accordance with the *mudharabah* agreement. The liability of the financier is limited to the extent of his capital and no more.⁸⁸

Sharikah literally means a mixing of shares (*khalat*) until they could not be distinguished from the other while according to *Shara'*, *sharikah* is a transaction between two or more people which agreed to perform some work for the purpose to get a profit⁸⁹. According to Ibn-e-'Abidin, *Sharikah* has also been defined as a contract between two or more people for participation in a capital and its profit⁹⁰." According to al- Khayyat, *sharikah* means "a contract between two or more owners of wealth for joint trade or it is a contract for shared labour and shared profits"⁹¹. The legality of *musharakah* or *sharikah* contract can be found in the Al-Quran, Sunnah and the consensus of Muslim jurists. Allah mentioned in the Al-Quran "...but if more than two, they share in a third..."⁹² This verse specifically highlights the rule of Islamic inheritance. However, in general context, Muslim jurists have considered the text as containing general permissibility of any form of partnership.

"Verily many are the partners (in business) who wrong each other except those who believe and work deeds of righteousness and how few of them...."⁹³

In the verses above, Allah SWT describes the partnership of a property. If a person dies without leaving behind any ascendants or descendants, but he has brothers and sisters more than two in number, then they will share a

⁸³ Muhammad Umer Chapra, *Towards a Just Monetary System*, vol 2 (1990).

⁸⁴ Nicholas HD Foster, 'Islamic Perspectives on the Law of Business Organisations I: An Overview of the Classical Sharia and a Brief Comparison of the Sharia Regimes with Western-Style Law' [2010] *European Business Organization Law Review* 3.

⁸⁵ IAK Nyazee, *Islamic Law of Business Organization: Partnerships (Malaysian Ed.)* (Kuala Lumpur: The Other Press 2002).

⁸⁶ Similar situation happens in Qatar, whereby the term *sharikah* is used intermingle between Partnership and Company, see Appendix 3 Qatar Commercial Companies Law 2015.

⁸⁷ Chapra, *Towards a Just Monetary System* (n 37).

⁸⁸ Chapra, *Towards a Just Monetary System* (n 37).

⁸⁹ Burhanuddin Susanto, 'Pendapat Al-Mazāhib Al-Arba' Ah Tentang Bentuk Syirkah Dan Aplikasinya Dalam Perseroan Modern' (2014) 6 *de Jure: Jurnal Hukum dan Syariah* 10.

⁹⁰ Hafëez (n 32).

⁹¹ Nyazee, *Islamic Law of Business Organization: Partnerships (Malaysian Ed.)* (n 39).

⁹² Al-Quran, Surah An-Nisa : 12

⁹³ Al-Quran, Surah Al-Sad: 24

third of the property of the mortal. On this basis, the partnership of a property is legal in the shariah⁹⁴. The permissibility of musharakah also can be traced from several hadith.

*Narrated by Abu Hurayrah: The Prophet (p.b.u.h) said: "Allah says: I am the third (partner) of the two partners as long as they do not betray each other. When one of them betrays the other, I depart from them".*⁹⁵

Another narration by Abu al-Minhal whereby he narrated that:

*"Zayd Ibn Arqam and al-Barra' Ibn 'Azib were partners, and they bought silver in cash and credit. Their practices were brought to the Prophet pbuh, and the Prophet pbuh pronounced that "if it is from hand to hand, there is no harm in it; otherwise it is not permissible."*⁹⁶

The Prophet (pbuh) approves the people using the partnership contract and did not question their practice, and there are many hadith that indicate his approval of the contract. The wisdom in permitting partnerships is to allow individuals to combine their properties in a manner that enable them to produce more wealth than they could each produce individually⁹⁷. Based on the narration, it appears that, the Prophet Muhammad pbuh approved the partnership formed between Zayd Ibn Arqam and al-Barra' Ibn 'Azib but disapproved their venture into business activity of purchasing silver on credit⁹⁸. Muslim jurist unanimously agreed that *sharikah* is permissible in Islam but were dispute on the division of it. As mentioned by Susanto⁹⁹ in his article, Abdurrahman Al-Jaziri in *Kitâb al-Fiqh 'alâ al-Mazâhib al-Arba'ah* stated that, Imam Hanafiyah, had divide *sharikah* into two types: *sharikah al-milk* (non-contractual) and *sharikah al-uqud* (contractual).

Sharikah al-milk (non-contractual partnership) implies co-ownership and comes into existence when two or more persons who happen to get joint-ownership of some asset without having entered into a formal partnership agreement, for example, two persons receiving an inheritance or gift of land or property which may or may not be divisible. The partners have to share the gift, or inherited property or its income, in accordance with their share in it until they decide to divide it (if it is divisible, e.g., land) or sell it (if it is indivisible, e.g., a house or a ship). The *sharikah al-milk* can be divided into *sharikah al-milk ikhtiyariyyah* for which the partners still decide to stick together even the property is divisible and, if it is indivisible it will be characterized as *sharikah al-milk jabriyyah* (involuntary). The essence *Sharikah al-milk* is that the common ownership of property will not be considered as a partnership in a strict sense so long there is no mutual agreement with regards to share profits and risk. However, according to Sayid Sabiq in *Fiqh Sunnah*, *sharikah milk* is not allowed because, each partner has a right to deal with its portion of property even though, without authorisation from the other counterparty¹⁰⁰. Whereas according to Wahbah Zuhaili in *Al-Fiqh al-Islâmî wa Adillatuhu*, each partner should be treated as a separate entity and is not allowed to deal with the shared property without authorisation from other partners¹⁰¹.

Sharikah al-'Uqud means two or more people coming together to make a contract for the investment of their profit. According to Chapra, *Sharikah al-'uqud* (contractual partnership) can, however, be considered a proper partnership because the parties concerned have willingly entered into a contractual agreement for joint investment and sharing of profits and risks. The agreement can be done orally and informal without a formal written agreement. However, it would be preferable if the *sharikah al-'uqud* is formalised by a written agreement with proper witnesses, specifically stating the agreed terms and conditions in conformity with the Qur'anic teachings about loans and important business transactions¹⁰². Just as in *mudharabah*, the profits can be shared in any equitably agreed proportion. Losses must, however, be shared in proportion to capital contributions¹⁰³.

⁹⁴ Noraziah Che Arshad and Abdul Ghafar Ismail, 'Shariah Parameters for Musharakah Contract: A Comment' (2010) 1 International Journal of Business and Social Science 145.

⁹⁵ Sunan Abu Dawud, Book 23, No 3383 retrieved in <https://sunnah.com/abudawud/23/58>

⁹⁶ Sahih Al-Bukhari, Vol 3, Book 34 : 276 retrieved in https://www.sahih-bukhari.com/Pages/Bukhari_3_34.php

⁹⁷ Arshad and Ismail (n 48).

⁹⁸ Purchasing silver on credit is consider Haram in Islam since it amounted to Riba .

⁹⁹ Susanto (n 43).

¹⁰⁰ Susanto (n 43).

¹⁰¹ Wahbah Al-Zuhaili, *Al-Fiqh Al-Islamiy Wa Adillatuhu* (3rd editio, Dar al-Fil 1989).

¹⁰² Al-Quran, Surah Al-Baqarah : 282-283

¹⁰³ According to the Shaf'i school, even profits should be divided in proportion to capital contributions. This is because the contribution of labour (or skill and management) is difficult to measure and it is assumed that labour will be contributed equally. Profits, like losses, should also be in proportion to the risk shared. However, if two partners contribute to the capital and only one of them works, then even according to the Shaf'i school, the working partner's share in the profit should be higher. (Ibn Rushd, 1960, vol. 2, pp. 253-45; Al-Marghinani, *al-Hidayah*, n.d., vol. 3, p. 7.

Sharikah al- 'uqud has been divided in the fiqh books into four kinds : *al-Abdan* (labour, skill and management), *al-Wujud* (goodwill, credit-worthiness and contacts), *al-Mufawadah* (full authority and obligation) and *al- 'Inan* (restricted authority and obligation)¹⁰⁴.

*Sharikah al- abdan*¹⁰⁵ is where the partners of a company contribute their skills and effort to the management of the business without contributing to the capital. In *sharikah al-wujud* the partners use their goodwill, credit-worthiness and contacts for promoting their business without contributing to the capital¹⁰⁶. Both these forms of partnership, where the partners do not contribute any capital, would tend to remain confined primarily to small-scale businesses.

In the case of *al-mufawadah*, the partners are adults, equal in their capital contribution, their ability to undertake responsibility and their share of profits and losses. These partners, have full authority to act on behalf of the others and are jointly and severally responsible for the liabilities of their partnership business, provided that such liabilities have been incurred in the ordinary course of business. Thus each partner can act as an agent (*wakil*) for the partnership business and stand as surety or guarantor (*kafil*) for the other partners¹⁰⁷.

Al- 'Inan on the other hand does not require all partners to be adults or have an equal share in the capital. They need not be equally responsible for the management of the business. Accordingly, their share in profits may be unequal, but this must be clearly specified in the partnership contract. Their share in losses would of course be in accordance with their capital contributions. Thus, in *sharikah al- 'inan* the partners act as agents but not as sureties for their colleagues¹⁰⁸. Hence their liability towards third parties is several but not joint.

According to Wahbah Zuhaily, by referring to Ibn al-Mundhir, '*inan*' is a form of partnership in which the partners' sharing of capital, as well as profits and losses, is approved by consensus¹⁰⁹. The partners' contributions in *sharikah 'inan* need not be equal in capital and in their legal rights for using the property. Thus, one party may contribute more than another to the partnership, and one of the partners may have the exclusive right to run the affairs of the partnership. They have been given great variation in legal rights of dealing in the joint property. They are only responsible for the transactions that they themselves performed. The share of profit is according to any rule they agreed upon in the contract, whereas the losses is based on the proportion to their contributions to the partnership's capital¹¹⁰. The general rule is summarised by Wahbah Zuhaily as follows "profits are shared according to the parties' conditions, but losses are shared according to their shares in the capital"¹¹¹. Chapra also highlights the following: "the partners may contribute not only finance but also labour, management and skills, and credit worthiness and goodwill, and may not necessarily provide these equally"¹¹². The '*inan*' form, is more practical and recognised by all schools because it allows the contribution of an unequal shares therefore, becomes the most popular and widely used form of partnership.

The feature of *sharikah* can be found by looking at each of its underlying contracts. Under Shariah, the existence and validity of shariah business structure is mainly based upon contractual principles¹¹³. Apart from the main contract such as *mudharabah* and *musharakah*, there are specific underlying contracts as the basic rules that govern the relationship between partners, their various right and liabilities, and even the right owed to the third parties. There are four basic contracts that can operate on a partnership¹¹⁴ but these contracts do not exist simultaneously in one partnership contract. These contract are, the contract of *amanah*(trust), the contract of *wakalah*(agency), the contract of *kafalah*(surety) and the contract of *ijarah* (hire)¹¹⁵. The contract of *kafalah* does not operate in

¹⁰⁴ Chapra, *Towards a Just Monetary System* (n 37).

¹⁰⁵ This is also called *Sharikah al- 'mal* (partnership in labour or management), *sharikah al-sana' ah* (partnership in crafts or art) and *sharikah al-taqabbul* (partnership in contracting) .*Abdan* is the plural of *badan*, which means body, and refers technically to the effort and skills made available by the partners. *Sharikah al- abdan* is not recognized by al-Shafi'i, according to whom *sharikah* arises from the pooling of only financial resources because, as indicated above in footnote 4, the contribution of work and skills cannot be measured precisely and it is assumed that all partners will contribute these equally to the partnership (see Ibn Rushd, 1960, vol. 2, p. 255)

¹⁰⁶ *Wujud* is the plural of *wajh*, which means face, and refers here to the strengths associated with a person's own reputation, goodwill and credit-worthiness. *Sharikah al- wujud* or credit partnership is not recognized by the Maliki and Shafi'i schools (Ibn Rushd, 1960, p. 255).

¹⁰⁷ The Hanafi, the Maliki and the Hanbali schools, all recognize *mufawadah* partnership, with some differences. The Hanafis require that there be equality of the partners in net wealth and that the entire net wealth should enter the partnership business. The Malikis do not consider this to be necessary. They require only the equality of capital contributions (see Ibn Rushd, 1960, vol. 2, pp. 252-5; and al-Sarakhsi, *Al-Mabsut*, 1978, vol. 11, p. 177)

¹⁰⁸ *Al-Hidayah*, vol. 3, p. 4; see also *Majallah*, Article 1335; and Udovitch 1970, pp. 134-5.

¹⁰⁹ Zuryati, Azrae and Yusoff .

¹¹⁰ Chapra, *Towards a Just Monetary System*.

¹¹¹ Zuryati, Azrae and Yusoff .

¹¹² Chapra, *Towards a Just Monetary System* .

¹¹³ Zuhairah Ariff Abd Ghadas, Nasarudin Abdul Rahman and Halyani Hassan, "'Shari'ah Corporation": The Legal Entity of Corporation from the Malaysian Law and Shari'ah Perspective' (2013) Vol. 6, No International Journal of Liability and Scientific Enquiry(IJLSE) <<http://www.inderscience.com/jhome.php?jcode=ijlse>>.

¹¹⁴ Nyazee, *Islamic Law of Business Organization: Partnerships (Malaysian Ed.)* .

¹¹⁵ Nyazee, *Islamic Law of Business Organization: Partnerships (Malaysian Ed.)*.

Muzaraah, *Mudharabah* and *Musaqah*¹¹⁶. Whereas a contract for *ijarah* does not have any role in *inan* and *mufawadah* and therefore, it will not be discussed further here. The underlying contracts for *sharikah inan* are the contract of *amanah* and *wakalah*.

An important legal effect of a contract of *sharikah* is the fiduciary position that the partners hold in relation to the partnership property and capital, whereby the exercise of necessary prudence and avoidance of harm is the overriding principle. This may be equivalent to the common law concept of good faith and the fiduciary duties of partners to each other. In *Sharikah*, majority of the Muslim jurists agree that it is not a binding contract, meaning that the partners can terminate the contract at any time they wish to. This may be quite similar to the concept of partnership at will under English law. Thus, it is clear that corporations under Islam require a specific legal rule distinct from the common law. The partnership liability derives from the fact that partnership is always a contract between its partners and according to this contract, the partners' liability is unlimited as explained above.

3.0 TYPES OF COMPANIES

3.1 Common Law

Under the common law, an incorporated company can be divided into company limited by shares, by guarantee or by unlimited companies. Details of each types of company are discussed in this chapter with reference to the Malaysia Companies Act 2016 which adopts the common law principles:

i. Companies Limited by Shares

Section 10 of Companies Act 2016, defines a company limited by shares as the liability of its members which are limited to the amount of any unpaid on shares held by the members. Most of the companies are limited by the shares held by the company's shareholders. In such a company, the shareholders' obligation is to pay the company for the shares they have taken in it. For example, a person puts money into a company, and in return the company gives it a percentage of ownership in the form of shares and therefore, the liability of a member in the company limited by shares to contribute to its assets upon its being wound up which does not exceed the amount, of any unpaid shares. However, if the shares are fully paid, no further money is payable by the shareholders. Their liability to the company is satisfied. In other words, the liability of the shareholder is limited to the amount they have paid, or they are due to pay, to provide adequate consideration for the shares that they own

ii. Company Limited by Guarantee

Company limited by guarantee is the liability of its members is limited to the amount that the member undertakes to contribute in the event of winding up. In this company, no shares are held by the members, hence there are no shareholders. Instead, the company will have "members". The members of a company limited by guarantee are bound by a guarantee in the company's articles of association, which requires them to pay the company's debts up to a fixed sums specified in the memorandum or article of association.

iii. Unlimited Companies

An unlimited company is defined as "a company formed on the principles of having no limit placed on the liability of its members". The classification of companies can further be subdivided into a private and public company. A company limited by shares and unlimited companies are further divided into private and public companies, whereas a company limited by guarantee shall only be public companies.

iv. Private Company

The function of a private company is to serve as a convenient vehicle to enable a family or small business to avail themselves of the advantages of a corporate entity. A private company can be used as a subsidiary in a group of companies to evade, as far as the law permits the stricter disclosure requirements that are obligatory for public companies. For a company to be registered as a private company, it must have a share capital and follow certain restrictions and prohibition for private companies such as restricting the right to transfer its shares¹¹⁷, limiting its members to not more than fifty members, prohibiting any invitation to the public to subscribe for any shares in or debentures of the company, and prohibiting any invitation to the public to deposit money with the company for a fixed period or payable at call whether bearing interest or not¹¹⁸.

¹¹⁶ *Muzaraah* is an agreement in which one party agrees to allow a portion of his land to be used by the other in return for a part of the produce of the land; while *Musaqah* is a contract in which the owner of agricultural land shares its produce with another person in return for his services in irrigating the garden; and *Mudharabah* means a type of partnership for profit which is structured so that one partner provides capital and the other provides labor and expertise. Source; www.islamicfinancenews.com/glossary retrieved on 26th February 2017

¹¹⁷ Section 42 (2) Companies Act 2016

¹¹⁸ Section 43 of Companies Act 2016

v. **Public company**

A public company is a company other than a private company. A public company is not affected by the restriction, limitations and prohibitions laid down in Section 43. In other words, a public company may offer its shares and debentures to members of the public.

3.2 **Shariah**

In all Islamic countries, Shariah forms the basis of the legal system. However, according to El-Saadouni, difference is noted between Shariah being a mere source of reference and Shariah being the law¹¹⁹. In the first category, Shariah, is the law, while in the second category, Shariah is only a reference of the law. In regard to company law, most of the Islamic countries have commercial civil code¹²⁰. According to Cerigamic, multinational companies normally are more equipped in dealing with problems when governed by western legal philosophies and jurisprudence. However, when certain issues fall under the jurisdiction of an Islamic country they have to address it by using the Shariah laws¹²¹.

3.3 **The Company Law in Saudi Arabia**

The paramount body of law in the Kingdom of Saudi Arabia is the *Shariah*. In addition to the *Shariah*, Saudi Arabian law also consists various form of legislation namely, Royal Orders, Royal Decrees, Council of Ministers Resolutions, Ministerial Resolutions and Ministerial Circulars. All the legislations are subjected and subsidiary to the *Shariah*¹²². In the Kingdom of Saudi Arabia, the government attempts to harmonise the teachings of Islam with economic development and industrialisation by developing a legal system capable of meeting the needs of a modern society while remaining consistent with the principles of Islamic law¹²³. An example of the influence of French law in the area of private law is the Saudi Companies Law Royal Decree No. MJ dated 22 Rabi'a I 1385 (21 July 1965)¹²⁴. This law adopted from the Egyptian code which was based on the French company law before the amendments of 24 July 1966¹²⁵. The main reference of company law in Saudi is the Kingdom of Saudi Arabia Companies Act (KSA) 2015¹²⁶. Under the KSA, companies are referred as *Sharikah* which literally means a partnership. The term companies and *Sharikah* are used intermingle and the Act does not differentiate between companies and *Sharikah*.¹²⁷ Under the KSA Companies Act 2015, a company is a legal entity¹²⁸ but defined as "a contract under which two or more persons undertake to participate in an enterprise for profit, with each contributing a share in the form of money or services, with a view to dividing any profits (realized) or losses (incurred) as a result of such enterprise"¹²⁹. A partner's contribution may consist of a sum of money or a capital asset or even services, except where the provisions of the Companies Act imply otherwise, but may not consist solely of the partner's reputation or influence¹³⁰. Saudi law allows shareholders to agree that the profits of a shareholder need not reflect his ownership of the capital of the company¹³¹.

3.3.1 **Types of companies in KSA**

Under the KSA Companies Act 2015, there are five types of Companies¹³²:

i. ***Al-Sharikah al-Tadamun (General Partnerships):***

This company is similar to *société en nom collectif* in France, and parallel to English partnership. It is defined as an association of two or more persons who assume joint liability, to the extent of their entire fortune, for the partnership's debts¹³³.

ii. ***Al-Sharikah al-Tawsiya al-Basūah (Limited Partnerships)/Simple Partnership***

This company is similar to *société en commandite* in France and parallel to English partnership. This consists of at least one general partner, who is responsible to the extent of his entire fortune for the partnership's debts, and

¹¹⁹ El-saadouni (n 85).

¹²⁰ Shaaban (n 85).

¹²¹ Sabina Cerimagic, 'The Effects of Islamic Law on Business Practices' (2010) 3 Education, Business and Society: Contemporary Middle Eastern Issues 40.

¹²² Latham & Watkins LLP, 'Doing Business in Saudi Arabia' <https://www.lw.com/upload/pubContent/_pdf/pub3507_1.pdf>.

¹²³ Hanson (n 87).

¹²⁴ This act was repealed with the new Companies Law was enacted by Royal Decree No M3 dated 28/1/1437(10/11/2015G). It was published in the Official Gazette on 22/2/1437H(4/12/2015G) and has been enforced on 2 May 2016.

¹²⁵ Hanson (n 87).

¹²⁶ The new Companies Law was enacted by Royal Decree No M3 dated 28/1/1437(10/11/2015G). It was published in the Official Gazette on 22/2/1437H(4/12/2015G) and has been enforced on 2 May 2016.

¹²⁷ Refer to the Arabic version of KSA and English version of KSA in Appendix 2.

¹²⁸ Article 14 of KSA Companies Act 2015

¹²⁹ Article 2 of KSA Companies Act 2015

¹³⁰ Article 5 of KSA Companies Act 2015

¹³¹ Article 11 of KSA Companies Act 2015

¹³² Article 2 of KSA Companies Act 2015

¹³³ Article 17 of KSA Companies Act 2015

at least one limited and unnamed partner who is responsible for the partnership's debts to the extent of his interest in the partnership's capital¹³⁴. The law considers a general partner to be a trader and has the right to manage and run the partnership, which may take his name as its commercial name. A limited partner is not regarded as a trader and cannot manage the partnership nor add his name to its commercial name.¹³⁵ He may only participate in the internal management within the limit prescribed in the partnership contract, while his liability is limited to his share in the partnership capital¹³⁶.

iii. Al-Sharikah al-Mahasa (Joint venture):

This company is similar to *société en participations* in France and parallel with joint venture contract under the English Law. Under the KSA Companies Act 2015, *Sharikatal-Mahasa* is a company without legal personality¹³⁷. It may be formed without that formation being publicised. It is an association of which third parties are not aware and which neither enjoys a juristic personality nor is subject to the publication formalities¹³⁸.

iv. Al-Sharikah al-Musahama (Joint stock company)

This company is similar to *société anonyme* in France, and equivalent to Joint stock company under English Law. *Sharikat al-musahama* is defined as a company capital divided into negotiable shares of equal value. Its members (whose number shall not be less than five) are responsible only to the extent of the value of their shares¹³⁹.

v. Al-Sharikah Dhat Mas'uliyah al-Mahdudah (Limited Liability Companies)

This company is similar *société à responsabilité limitée* in France and equivalent to English law limited liability companies. Under the KSA Companies Act 2015, the sharikah is defined as a partnership consisting of two or more partners but must be less than 50. All the partners are responsible for the debts of the partnership to the extent of their respective interests in the capital¹⁴⁰.

4.0 ANALYSIS

Based on the above discussion, it is observed that the differences between a corporation under the common law and Shariah arise mainly due to the different sources of law. A corporation under the common law exists from the effect of registration under the Companies Act whereas under the Shariah, the existence of a corporation or any business entity is based on the contract of *musharakah*. In Shariah, the objective of conducting business must also be based on the principle of *Maqasid al-Shariah* is very important since, it was aim to protect the interest of the society and to prevent any harms. The *Maqasid Shariah* should be the basis of business framework in order to achieve the real wellbeing of the society. The application of *Maqasid Shariah* in business framework represent the level of *taqwa* to Allah because wealth is a trust from God and needs to be developed and used honestly for removing poverty, fulfilling the needs of all and promoting equitable distribution of income and wealth. Its acquisition as well as use needs to be predominantly for the purpose of realizing the *maqasid*. This is where faith plays an important role through its values and its motivating system. Without the values that faith provides, it would then promote corruptness, imbalances and excesses, which could ultimately reduce the well-being of most members of both the present and future generations. Thus, it is important to highlight that; all business activity should be carried out based on sincerity and piety in the light of *Maqasid al-Shariah*.

The second observation in regard the differences between a corporation under the common law and the Shariah is that a corporation under the common law is based on the doctrine of body corporate which entails them some special attributes as an artificial person separated from its founder. Whereas, under Shariah, there is no concept of corporation as defined by the Common Law. The existence and validity of Shariah business structure is mainly based upon contractual principles between person (partnership) with the underlying contract of *wakalah* or *kafalah*. In many Islamic countries, the concept of *sharikah 'inan* had been used by Shariah scholars to define a companies. Various type of *Sharikah* are reflected to a company under common law such as *sharikah al-tawsiyyah al-basitah* for company limited by guarantee, *sharikah al-musahamah*, *sharikah al-tawsiyyah bil-asham* and *sharikah zatul mas'uliyah al-mahdudah* for company limited by share¹⁴¹. According to Yousef Ahmad Al-Kasem, some scholars have tried to connect each *Sharikah* type stipulated by the Saudi law to one and more categories of *Sharikah* as introduced by Muslim Jurists. This results in these five types matching the *Sharikah* as defined in the Islamic law and hence being accepted by Islamic jurisprudence¹⁴². The Arab countries believe that a corporation

¹³⁴ Articles 38 of KSA Companies Act 2015

¹³⁵ Article 39 of KSA Companies Act 2015

¹³⁶ Article 40 of KSA Companies Act 2015

¹³⁷ Article 43 of KSA Companies Act 2015

¹³⁸ Article 43 of KSA Companies Act 2015

¹³⁹ Article 52 of KSA Companies Act 2015

¹⁴⁰ Article 151 of KSA Companies Act 2015

¹⁴¹ Zuryati, Azrae and Yusoff (n 25).

¹⁴² El-saadouni (n 85).

is a kind of contract between shareholders or a *sharikah* because it is a relationship between the parties in sharing of the profit of the business. In Egypt, Syria, Libya, Lebanon, and other Middle East countries such as Qatar and Kingdom of Saudi Arabia, *sharikah* is a contract (*'aqd*) whether or not the *sharikah* enjoys a legal personality¹⁴³. As mentioned by Imran, this arise because, most scholars have worked under a false assumption committed by the Egyptian law which assumes that a corporation is a contract, and this notion consequently led many scholars, and even the Islamic Fiqh Academy, to apply the principles of partnership and even co-ownership to institutions that are really corporations with an independent legal personality, simply because these companies are designated as *sharikat*.

5.0 CONCLUSION

The corporation under common law was based on the doctrine of body corporate as an artificial person while under the Shariah it is based on *sharikah* or partnership. Thus, it shows that there is dissimilarity in the concept of corporation between common law and shariah. From the existence a corporation does not fulfil the conditions of a contract of partnership. A partnership is always a contract between the partners or it is the relationship that arises from such a contract. The existence of the corporation depends upon the charter granted by the state, and it is not a contract between the shareholders nor is it the result of a contract between the shareholders or between the promoters¹⁴⁴. It appears that in the Islamic countries, the term *sharikah* is used interchangeably between partnership and company. It is suggested that, the use terminology be more precise in order to clarify the concepts. Using different terms would not resolve the issue of the nature of corporations. It may thus be concluded that the regime applicable to the partnerships in Shariah cannot be applied to corporations, which should have their own regime. The word *Sharikah* as used in fiqh in the sense of a contract cannot be applied to the corporation that enjoys a legal personality of its own, just as the word “partnership” used in English law cannot be applied to corporation. Neither does the meaning of the word *Sharikah* in Fiqh (mixing of shares, and the contract between the partners) applies to a corporation¹⁴⁵.

As a conclusion, the closest framework that can be suggested for a Shariah compliant corporation is a partnership with a status of a body corporate. Such business structure shall have both features of partnerships and company. The entity will have all attributes of a body corporate, namely, separate legal entity, limited liability, perpetual succession and legal entity yet at the same time retaining the internal flexibility of a partnership which is based upon partners' agreement.

¹⁴³ Nyazee, *Islamic Law of Business Organization : Corporation* (n 8).

¹⁴⁴ Hafeez (n 32).

¹⁴⁵ Susanto (n 43).

REFERENCES

- Abd Ghadas, Z. A., & Engku Ali, E. R. A. (2012). The Development of Partnership Based Structure In Comparison To the Concept of MushÉarakah (Sharikah) with Special Reference to Malaysia. *Journal of Islam in Asia* (E-ISSN: 2289-8077), 8(2), 293–315. <https://doi.org/10.31436/jia.v8i0.248>
- Abu Ghuddah, A. A.-S. (2004). Al-Sharikat Al-Hadithah, Al-Sharikat Al-Qabidhah Wa Ahkamuha Al-Shari'yyah. In *Majallat Majma' Al-Fiqh Al-Islami Li Mu'tamar Majma' Al-Fiqh Al-Islami*. Vol 2.,
- Accounting and Auditing Organization for Islamic Financial Institutions (AAOIFI). (2015). *Shariah Standards for Islamic Financial Institutions*. Dar Al-Maiman for Publishing and Distributing.
- Al-Hujailani, A. A. M. A. (2002). *Tasarrufat Al-Amin Fi Al-Uqud Al-Maliyyah* (1st edn). Vol 1, Majallah Al-Hikmah, Great Britain.
- Al-Khalil, A. M. (2002). *Al-Ashum Wa Al-Sanadat Wa Ahkamuha Fi Al-Fiqh Al-Islami* (1st edn). Dar Ibn Al-Jawzi.
- Al-Khayyat, A. A. (2004). Al-Sharikat Al-Qabidhah Wa Ahkamuha Al-Syari'yyah. In *Majallat Majma' Al-Fiqh Al-Islami Li Mu'tamar Majma' Al-Fiqh Al-Islami*. Vol 2.
- Al-Qarhadaghi, A. M. A. (2007). Al-Sifat Al-Mu'thirah Fi Al-A'laqah Baina Al-Sharikat. In *Hawliyyah Al-Barakah, Majallat A'maliyyah Mutakhassisah Bi Fiqhi Al-Mua'malat Wa Al-A'mal Al-Masrafi Al-Islami*. Majmua'h Dallah Al-Barakah Al-Amanah Al-A'mah Li Al-Haiah Al-Shariyyah.
- Al-Soifi, A. A. (2006). *Al-Sharikat Al-Qobidah Wa Ahkamuha Fi Al-Fiqh Al-Islami* (1st edn). Dar Al-Nafais.
- Al-Zaa'mtari, I. A.-D. (2012). *Mawsua'h Fiqh Al-Mua'malat Al-Maliyyah Al-Muqoron*. Dar Al-Usuma'.
- Bakar, M. D. (2007). Al-Sifat Al-Mu'thirah Fi Al-A'laqah Baina Al-Sharikat. In *Hawliyyah Al-Barakah, Majallat A'maliyyah Mutakhassisah Bi Fiqhi Al-Mua'malat Wa Al-A'mal Al-Masrafi Al-Islami*. Majmua'h Dallah Al-Barakah Al-Amanah Al-A'mah Li Al-Haiah Al-Shariyyah.
- Dix, M. J. (1953). The Economic Entity. *Fordham Law Review*, 22(3). <https://ir.lawnet.fordham.edu/flr>
- El-Gari, M. A. (2015a). *Al-Shakhsiiyyah Al-I'tibariyyah Dzat Al-Ghard Al-Khas*.
- El-Gari, M. A. (2015b). Al-Takyif Al-Fiqhi Li Ashum Sharikat Al-Musahamah. *6th Shura Fiqh Conference 2015*. <http://shura.com.kw/conferenceDesc.asp?pageID=21&confID=27>
- El-Saadouni, R. (2013). *The Liability of Groups of Companies in Islamic Law (A Comparative Study with Common Law)* (Issue November). University of Stirling.
- Haikal, S. O. (2019). Re-Examining the Structure of Firms and the Provision of Finance: The Case for Islamic Partnerships. *Asian Social Science*, 15(10), 64. <https://doi.org/10.5539/ass.v15n10p64>
- Levenberg, P. N. (2019). The Mystery of the Corporate Veil: Comparing Anglo-American Jurisdictions. *Penn State Journal of Law & International Affairs*, 7(1), 115.
- Lipton, P. (2014). The Mythology of Salomon's Case and The Law Dealing with The Tort Liabilities of Corporate Groups: An Historical Perspective. *Monash University Law Review*, 40, 452.
- MASB Standard 12 Investments in Associates, 1 (2000) (testimony of Malaysian Accounting Standards Board).
- Meng, C. W. (2017). *Essential Company Law in Malaysia, Navigating The Companies Act 2016*. Thomson Reuters.
- Mohd Sulaiman, A. N., & Othman, E. (2018). *Malaysia Company Law: Principles and Practices* (2nd edn). Wolters Kluwer.
- Muhammad Nur, `Ali. (2019). Al-Takyif Al-Fiqhi Li Sharikah Al-Musahamah wa Ashumiha. *8th Shura Fiqh Conference 2019*.
- Murali, K. M., & R. A. (2018). A Study on The Concept of Juristic Personality. *International Journal of Pure and Applied Mathematics*, 120(5), 99.
- Nyazee, I. A. K. (2006). *Islamic law of Business Organization: Partnerships*. The Other Press.
- Nyazee, I. A. K. (2010). *Islamic law of Business Organization: Corporations*. Adam Publishers & Distributors.
- Petrin, M., & Choudhury, B. (2018). Group Company Liability. *European Business Organization Law Review*, 19(4), 771–796. <https://doi.org/10.1007/s40804-018-0121-7>
- Rachagan, S., Pascoe, J., & Joshi, A. (2010). *Concise Principles of Company Law in Malaysia* (2nd edn). LexisNexis Malaysia.
- Sadique, M. A. A.-R. (2009). *Essentials of Musharakah and Mudarabah: Islamic Texts on Theory of Partnership*. IIUM Press.
- Sano, Q. M. (2004). Al-Sharikat Al-Hadithah Al-Sharikat Al-Qabidhah Wa Ahkamuha Al-Shari'yyah. In *Majallat Majma' Al-Fiqh Al-Islami Li Mu'tamar Majma' Al-Fiqh Al-Islami* (14th sess). Vol 2.,
- Wizarah Al-Awqaf wa Al-Shuun Al-Islamiyyah Kuwait. (1992). *Al-Mawsu'ah Al-Fiqhiyyah* (1st Edn). Vol 26.

AN ANALYSIS ON THE LEGAL CONCEPT OF GROUP OF COMPANIES UNDER COMMON LAW AND SHARIAH

Zuhairah Ariff Abd Ghadas^{*a}, Nazri Ramli^b, & Hartinie Abd Aziz^a

Faculty of Law and International Relation, Unisza, Malaysia

Abstract

The legal concept of group of companies under common law lies on the ownership structure between the holding and subsidiaries. The holding company generally has majority ownership of the subsidiaries and has a controlling interest in the latter. Under Shariah, there is no concept of corporation but *sharikah* is often used to define types of companies as practiced in Islamic countries. It is interesting to see that the concept of group of companies are also practised in the Islamic countries under the structure of *sharikah*.

This article discusses the legal concept of group of companies under both the common law and Shariah. Special reference is made to Malaysian company law as a sample of the common law and to the Qatar company law as a sample for the Shariah. The discussion is important since the existing practises in Islamic countries are to apply the common law concept of group of companies and this may lead to confusing outcomes. This article adopts the doctrinal analysis research methodology. Findings of the article highlight that the concept of group of companies under common law cannot be directly applied in *sharikah* due to the different legal structures.

Keywords: Group of Companies, *Sharikah*, Common Law, Shariah

1.0 INTRODUCTION

A company is a modern business organization that operates as an artificial legal entity distinct from its members. It may own assets under its own name. The company may incorporate or own shares in another company (Mohd Sulaiman & Othman, 2018). This concept often refers to corporate group of companies. A corporate group pertains to a company holding shares of other companies where its shares could also be held by another company. In *Walker v Winborne* (1976) 137 CLR 1, Mason J held that the term 'corporate group' basically applies to a number of companies which are associated by common or interlocking shareholdings, allied or unified control or capacity or control. The concept of group of companies consists of a relationship between holding or parent and its subsidiaries or affiliates with different amount of shareholding ownership and control.

In Malaysia, this corporate group concept is mainly derived from common law as envisaged under the Companies Act 2016 ("CA 2016"). Interestingly, the same concept has been applied and adopted in other Islamic countries. The difference is that these Islamic countries define the concept of corporation and its corporate group as partnership which likely resembles the traditional concept of *sharikah* under Shariah. Generally, although the current corporate group structure is non-existent under Shariah, numerous contemporary Muslim scholars discussed and viewed that such concept is not unfamiliar to the concept of *sharikah* under Shariah. However some of them disagree and refute that the concept is not amount to *sharikah* due to their different concept and structures altogether.

This article aims to discuss the legal concept of group of companies under both the common law and Shariah. Special reference is made to Malaysian company law as a sample of the common law and to the Qatar company law as a sample for the Shariah. The discussion is important since the existing practises in Islamic countries apply the common law concept of group of companies under the definition of *sharikah* and this may lead to confusing outcomes. This article adopts the doctrinal analysis research methodology.

2.0 CORPORATION AND ITS LEGAL ATTRIBUTES UNDER COMMON LAW

A company is an artificial legal person. Upon its incorporation, it comes into existence as a separate legal entity being distinct from its members and officers. This principle was firmly established in the classical legal case of *Salomon v Salomon & Co Ltd* (1897) (Meng, 2017). In this case, the court held that Salomon's company is a

separate legal person distinct from Mr. Salomon and other shareholders upon incorporation. In general, under common law, the doctrine of corporate personality regards a corporation as separate legal personality having assigned with a few legal characteristics such as to own its assets and incur its liabilities, be perpetually immortal, to hold property under its name, has right to sue and to be sued and others (Murali & R, 2018). Extensively, this concept has also been applied to group of companies which have been dominating the whole corporate legal system and corporate governance around the world (Lipton, 2014).

3.0 LEGAL CONCEPT OF GROUP OF COMPANIES UNDER COMMON LAW AND MALAYSIA LAW

3.1 Definition of group of companies

According to Rachagan, the term 'group' used with reference to companies in company law refers to corporations or companies that are related to each other. Related companies are those which have a holding subsidiary relationship between themselves (Rachagan et al., 2010). Petrin and Choudhury defined corporate group as 'business enterprise or firms that order their operation using a structure involving parent companies and subsidiaries' (Petrin & Choudhury, 2018, p. 2). A tenet conception of corporate group is one that consists of several companies related through controlling shareholdings through majority and minority shareholdings. It may happen without shareholdings such as control from family ownership or significant influence through common management or works (Petrin & Choudhury, 2018).

It is highlighted that the classification of these group of companies is material for accounting and regulatory purposes. From the former, it aims for preparing consolidated accounts in that the directors of holding company are obliged to report state of affairs of the holding and its subsidiaries. For the latter, it purports to prohibit certain dealing and transactions among themselves (Rachagan et al., 2010).

3.2 Group of companies under CA 2016

Under Section 4(1) of the CA 2016, a company is a subsidiary of another company (holding company) if (a) the holding company (i) controls the composition of the board of directors of the subsidiary company or; (ii) controls more than half of the voting powers of the subsidiary company or (iii) holds more than half of the issued share capital of the subsidiary company, excluding any preference shares; or (b) the corporation is a subsidiary of another company which is also the holding company's subsidiary. Section 4(2) explains that the composition of a corporation's board of directors shall be deemed to be controlled by another corporation if that other corporations can appoint or remove all or a majority of the directors. Furthermore, it mentions that the holding company shall be deemed to have the power to make such an appointment if (a) a person cannot be appointed as a director without the exercise of such a power in his favour by that other corporation or (b) a person's appointment as a director follows necessarily from his being as a director or other officer of that corporation.

Next, Section 5 of the CA 2016 stipulates a corporation as an ultimate holding company of another corporation if (a) the other corporation is a subsidiary of the corporation; and (b) the corporation is not itself a subsidiary of any corporation. Section 6 also defines a wholly-owned subsidiary corporation of another corporation if it has no members except (a) that other corporation or its nominee or (b) a wholly owned subsidiary of that other corporation or its nominee. Section 7 mentions that a corporation is deemed to be related to each other if (a) it is the holding company of another corporation; (b) it is a subsidiary of another corporation; or (c) it is a subsidiary of the holding company of other corporation. Section 6 impliedly governs affiliates companies such as associates and sisters whereby their shareholding ownership are below fifty percent of parent-subsidiary shareholding ownership. For instance, under the Malaysian Accounting Standard Board Standard (MASB) No 12 (Investments in Associates), an associate company is an enterprise in which the investor has significant influence that is neither the latter's subsidiary. Significant influence is defined as the investor who holds at least twenty percent or more of voting powers of the associate company (*MASB Standard 12 Investments in Associates*, 2000)

3.3 Legal attributes of group of companies

According to Mohd Sulaiman and Othman, the application of the doctrine of separate legal entity entails that a company may incorporate another company under the formation of related bodies corporate or group of companies. In other words, regardless of the relationship between parent and subsidiaries or affiliates with majority shareholding ownership, voting block or control, by virtue of such legal doctrine, they are regarded as a separate legal entity distinct from each other. The implications of applying this doctrine into these corporate structures are that they must be treated as separate entities even though the subsidiary is wholly owned by its parent, the

subsidiary's profit does not belong to its parent for the purpose of declaring its dividend, and even though both subsidiary and parent share the same directors (Mohd Sulaiman & Othman, 2018). In the case of *People's Insurance Co (M) Sdn Bhd v People's Insurance Co Ltd* [1986] 1 MLJ 68, the court held that the plaintiff, the subsidiary of the defendant, failed to claim against its own parent company for shortfall of policy claim although the plaintiff's directors who were also the senior officers of the defendant resolved that the defendant would guarantee such shortfall. Since both are treated as separate entities, the officers of the parent sitting on the board of the subsidiary are not representatives of the parent but rather the agent of the subsidiary itself.

Alongside the principle of separate legal entity, limited liability is the main feature underpinning the corporate structure. The main idea of having limited liability for corporation is highlighted by the Court of Appeal in *Zamri Bin Arshad & 20 Others v. Misc Intergrated Logistics Sdn Bhd* [2018] 1 LNS 1103 which referred to the principle in *Abdul Aziz bin Atan v Ladang Rengo Malay Estate Sdn Bhd* ruling that the whole purpose of forming a limited company is to enable the shareholders having their hands in the management of the business without incurring the risk of being unlimited liability for the debts of the company. According to Lipton, the principle of separate legal entity and limited liability as early introduced in *Salomon's* case was applied in the context of holding and subsidiary companies by the old case of *The Gramophone and Typewriter Ltd v Stanley* [1908] 2 KB 89. (Lipton, 2014) In this case, Walton J held that by applying the principle in *Salomon*, the business of German company is not the business of its parent English Company even though the latter held all shares in the former. Such all shares held by the parent over its subsidiary does not make the German company a mere alias, or a trustee, or an agent for the English company or for the shareholders in the English company.

In corporate groups, limited liability applies where the creditors of the subsidiaries cannot sue their parent company in the event the former fails to satisfy their debts. Thus, the parent may not incur its subsidiaries' liabilities except for the unpaid investment. However, such general principle may be circumvented by adopting the lifting corporate veil principle. Levenberg asserted that the English courts may lift veil in the context of corporate groups as sought by the shareholders themselves voluntarily on the basis of agency principle, single economic entity principle and the partnership substance in their internal relationships (Levenberg, 2019).

Firstly, the presence of an agency relationship between the holding company and its subsidiary can be a basis for the corporate veil to be lifted. (Mohd Sulaiman & Othman, 2018). The consequence of adopting this principle into this corporate group is that the acts, liabilities or assets of the subsidiary as an agent are attributed to its parent as the principal or controller (Lipton, 2014). This agency principle was applied in *Smith, Stones and Knight Ltd v Birmingham Corporation* [1939] 4 All ER 116. The local council sought a compulsory land acquisition over the land occupied by the subsidiary. The local council argued that the compensation was only made by the subsidiary as the occupier not the parent unless it could prove that the subsidiary was carrying business as agent of the parent. The court held that the parent company can claim compensation as owner-occupier because the subsidiary was in fact carrying on business as its agent. In arriving at the decision, the court laid down six guidelines to determine the existence of agency relationship between the holding company and its subsidiary which are as follows:

- (1) Were the profits of the subsidiary treated as the holding company's profits;
- (2) Were the persons appointed to manage the subsidiary's business appointed by the holding company;
- (3) Was the holding company the head and brain of the business;
- (4) Did the holding company govern the business, decide what should be done and what capital should be embarked on the venture;
- (5) Did the subsidiary make its profits by its skill and direction; and
- (6) Was the holding company in effectual and constant control.

Secondly, for single economic entity, Dix asserted that it is different from legal entity in a sense that it does not have corporate charter but rather an option of economic management. The economic entity renders a joint and merger of activity (unity of life) in reaching the common undertaking, endeavour or enterprises (Dix, 1953). The application of this theory was made in *DHN Food Distributors Ltd v Tower Hamlet London Borough Council* [1976] 3 All ER 462. The Court of Appeal held that the companies operated as one single economic unit and the veil should be lifted to allow for compensation for loss of business to be paid by the local council to the holding and its subsidiaries. It found that there was utter identity and community of interest between these companies, because the directors were the same persons, the subsidiaries were wholly owned, they had no separate business and they had no creditors other than the holding company. In *Hotel Jaya Puri Bhd v National Union of Hotel, Bar and Restaurant Workers* [1980] 1 MLJ 109, the court held that both hotel and restaurant were in reality one enterprise under a single economic unit. The fact that the workers who were retrenched by the restaurant were the employees of the hotel by which the restaurant business was carried on the premises belonging to the hotel. There was a presence of functional integrality and unity of establishment between the hotel and the restaurant. Being one

integral whole, single-management unit and sharing of the same managing director and senior officers strongly indicate their single economic unit. However, some cases disagree with this approach which contradict the tenet principle of company law. In *Ord v Belhaven Pubs Ltd* [1998] 2 BCLC 447 the court held that simply looking to the economic unit, to disregard the distinction between the legal entities that were involved and then to say: since the company cannot pay, the shareholders who are the people financially interested should be made to pay instead. That of course is radically at odds with the whole concept of corporate personality and limited liability.” In *Adams v Cape Industries PLC*, the Court of Appeal refused to consider the companies within the Cape group as a single economic unit nor to lift the corporate veil despite the high degree of control exercised by the parent company over the subsidiary. The economic inter-relationship of the corporate groups did not justify the veil piercing and therein departing from the Salomon principle.

4.0 CONCEPT OF SHARIKAH UNDER SHARIAH

The Islamic law acknowledges a wide form of business structures for multiple purposes such as commercial trading, investment, profit-driven and the like (Abd Ghadas & Engku Ali, 2012). One of the structures recognized is known as *sharikah/shirkah* or *musharakah*. Literally, *sharikah* denotes mingling or merging (*mukhalatah*). Jurists defined it as becoming merged (*ikhthilat*) which means “blending one of two properties (*mal*) with other in a way that the two cannot be differentiated one from the other” (Sadique, 2009, p. 4).

The definition of *sharikah* differs from one the Islamic school of thought (*madhab*) to another. As explained by Sadique (2009, pp.5-7) Hanafi jurists define *sharikah* as “a contract between two partners in the capital (*asl*) as well as the profit (*ribh*)”. Maliki jurists define *sharikah* as “permission (granted) to each other to transact while retaining the right with each”. According to Shafie jurists, *sharikah* is “every right (*haq*) established between two or more (parties) in common (*a'la al-shuyu'*)”. *Shuyu'* connotes the indistinguishable nature of the portion between partners, which signifies their joint and common entitlement to a subject matter. Hanbali jurists defined *sharikah* as “joining together in entitlement (*istihqaq*) or (the right of) transaction (*tasarruf*)”.

The definitions above addressed three aspects. Firstly, *sharikah* is essentially a contract between -at least- two or more parties. Secondly, it authorizes the partners to transact with the capital or partnership property. Thirdly, the element of profit-sharing as enunciated by the Hanafi jurists. All these three aspects are material for formulating elements (*arkan*) of a valid *sharikah* contract found in the scholars' traditional *fiqh* literatures (Abd Ghadas & Engku Ali, 2012).

There are various types of *sharikah* under Shariah. According to Nyazee, it is generally divided into two categories namely *sharikah al-mlik* and *sharikah al-aqd*. The former pertains to co-ownership by number of persons of an ascertained property (*'ayn*) or debt (*dayn*) arising through inheritance, exchange (*bai'*) or other means. The word *'ayn* here refers to joint and exclusive ownership of two or more persons resulting from one of the causes of ownership, or by the mixing (*khalt*) of their property in a manner that does not accept distinction or separation (Nyazee, 2006). For *sharikah al-aqd*, it means a partnership contract between two or more partners. It is mainly divided into five basic categories namely limited partnership (*sharikah al-inan*), equal partnership (*sharikah al-mufawadhah*), labor partnership (*sharikah al-abdan*), reputation partnership (*sharikah al-wujuh*) and lastly *al-mudharabah* or partnership between capital provider (*rabbul mal*) and entrepreneur (*mudharib*). (Nyazee, 2006) Despite differences between *sharikah al-milk* and *sharikah al-aqd*, there is no disagreement between the scholars that co-ownership is a consequence of *sharikah al-aqd* (Nyazee, 2010).

The primary purpose of the contract of *sharikah* is the sharing of profits. In addition, agency (*wakalah*) contract is among the basic underlying contracts in *sharikah* (Nyazee, 2010). Thus the agent can do almost anything that the principal would be permitted to do himself. A partner as an agent has all the powers, unless expressly restricted of the principal. Besides, the principal is bound by all these acts as regards third parties. (Nyazee, 2010). On this basis, among the conditions of the subject matter of *wakalah* is that it is owned by the principal or otherwise he cannot delegate such disposition to the agent (Al-Zaa'mtari, 2012).

It is also recorded that according to several Hanafi scholars, a partner in *sharikah al-mufawadhah* can enter into *sharikah al-inan* with a third party. As such, *sharikah al-inan* will constitute a branch (*fur'*) of *sharikah al-mufawadhah* similarly to a situation where a partner of *sharikah* can enter into *al-mudharabah* with third party (Wizarah Al-Awqaf wa Al-Shuun Al-Islamiyyah Kuwait, 1992). According to Hujailani, in relation to the issue of a person entering into *al-mudharabah* with a third party using the *sharikah's* property, he preferred the view of some Maliki and Hanbali scholars who asserted that such partner may enter into *al-mudharabah* subject to his partner's consent in the *sharikah*. The same view applies to participation of a partner of *al-mudharabah* into another *al-mudharabah* with the third party which requires his co-partner's consent (Al-Hujailani, 2002). Apart

from them, Al-Khalil also recorded views of some traditional scholars that it is permissible to combine *sharikah al-inan* with *al-mudharabah* (Al-Khalil, 2002).

5.0 RECOGNITION OF CORPORATION AND GROUP OF COMPANIES BY CONTEMPORARY MUSLIM SCHOLARS UNDER THE PURVIEW OF *SHARIKAH*

5.1 Recognition of joint-stock company (*sharikah al-musahamah*) under Shariah

The contemporary Muslim scholars generally disputed on the permissibility of a modern corporation or *sharikah al-musahamah* under Shariah since it is not similar to the classical *sharikah* as explained above. Some scholars such as Abduh and Al-Nabhani argued that it is not accepted entirely since its structures are originated from western capitalist system which contradict with *sharikah* principles (Nyazee, 2010). Their main arguments are that it lacks offer and acceptance since it can be structured by one member. Meanwhile, majority of the contemporary scholars such as Al-Khafif, Al-Zuhaili Al-Khayyat, Al-Baqmi and others accept *sharikah al-musahamah* under the purview of *sharikah al-i'nan* or *sharikah al-milk* or *al-mudharabah* and directly apply all these *sharikah* principles into the former (Al-Khalil, 2002). They rebutted the first view earlier by arguing that the offer and acceptance are fulfilled when the members agree to enter into the *sharikah al-musahamah*. In addition, it is argued that the board of directors are considered as an agent for their shareholders who run the company on their behalf (Al-Qarahdagi, 2007). The same approach is addressed in the Shariah Standards No. 12: *Sharikah* (Musarakah) and Modern Corporations of the Accounting and Auditing Organization for Islamic Financial Institution (AAOIFI) where Article 4/1/1 states that *sharikah al-musahamah* takes the ruling of *sharikah al-inan* (AAOIFI, 2015).

Nonetheless, there are some contemporary scholars who have recently criticized this majority's view. Firstly, El-Gari argued that both *sharikah al-musahamah* and *sharikah* are greatly different in several aspects. For instance, the Arabic word '*sharikah*', which means participation closely associated to the classical understanding of *sharikah* under Shariah, does not match with the literal meaning of corporation under common law. The latter is rather a separate legal entity distinct from its members. Secondly, the element of participation among the partners which is substantial to a valid *sharikah* is not required for the corporation since it can subsist with even one member. Hence, *sharikah al-musahamah* is not similar to *sharikah* from its literal meaning until the inner features counterpart as the former is originated from the western concept unfamiliar to the concept of *sharikah* under Shariah (El-Gari, 2015b). This is closely followed by Nur who viewed that *sharikah al-musahamah* is dissimilar to any type of *sharikah* under Shariah such as *sharikah al-inan* and *al-mudharabah* since the former is a separate legal artificial personality distinct from its own members by which such features does not in fact exist in all these types of *sharikah* (Muhammad Nur, 2019). For Al-Mansur, *sharikah al-musahamah* is mainly originated from western conventional legal system under the name of corporation that completely diverges from partnership. *Sharikah* under Shariah closely resembles partnership under common law although the Arabic dictionary does not differentiate between these two entities. This is parallel to the Arab law whereby it does not differentiate between aggregate entity and legal entity separately (Haikal, 2019). According to Nyazee, the existing legal structure of corporation must be modified in order to comply with *sharikah* principles and other Shariah principles as well such as revenue is upon liability assumption (*al-kharaj bi al-dhman*), prohibition of usury (*riba*) and etc (Nyazee, 2010).

5.2 Recognition of holding company (*sharikah al-qabidhah*) under Shariah

Similarly, alongside the above discussion, the contemporary scholars also discussed the concept of *sharikah al-qabidhah* from Shariah perspective. Firstly, according to Al-Khayyat, incorporation of holding company is permissible based on the principles of Shariah among others is consent which Allah says: "*Do not consume one another's wealth unjustly but only [in lawful] business by mutual consent*" (Al-Nisa; 29) as well as a maxim: "*sharikah* is contracted based on the customary practice of traders". He further mentioned that the classical scholars discussed the creation of *sharikah al-inan* or *al-mudharabah* as a subsidiary of *al-mufawadhah*. In addition Shariah does not prohibit parent company to own shares in its subsidiary so long it is based upon consent of all shareholders, does not affect other stakeholders dealing with the said company and ascertains the interest of such incorporation (Al-Khayyat, 2004). According to Abu Ghuddah, *sharikah al-qabidhah* takes similarly the ruling of *sharikah al-musahamah* which resembles *sharikah al-inan*. In fact all modern corporations do not fall apart from the Shariah principles of *sharikah* which is based upon *wakalah* contract (Abu Ghuddah, 2004). Al-Soifi also takes the same view that *sharikah al-qabidhah* resembles *sharikah al-inan* (Al-Soifi, 2006). However, Sano refuted that it is unnecessary to equate both *sharikah al-musahamah* and *sharikah al-qabidhah* with any types of *sharikah* under Shariah since both are greatly different in terms of its natures and essences. In fact, it is necessary to look them from other aspects such as whether *sharikah al-qabidhah* fulfils the general pillars, conditions of contracts and *sharikah* and complies with all Shariah principles of transactions (Sano, 2004).

According to El-Gari, among the essential features that mainly distinguish *sharikah al-musahamah* from *sharikah al-inan* is the separation of liabilities between the holding and its subsidiaries. Even though the latter wholly owns the former, both are regarded as separate legal entities and hence they do not incur liability to each other. Indeed, upon incorporation of subsidiaries, they remain separated from its holding despite they share similar directors, members or financial accounts (El-Gari, 2015b).

In addition, several scholars also discussed the concept of control in corporate groups particularly on whether such control would affect the independency of their existences and therein apply the principle of *sharikah* in certain situations from Shariah perspective. According to Bakar, the causal attribute in determining Shariah rulings in certain transactions between corporate groups under Shariah is the shareholding ownership leading to control. Control is the attribute that gives effect to the Shariah ruling in certain transactions between parent and its subsidiaries not the concept of separate legal entity and limited liability. In this regard, the parent cannot guarantee the capital amount of its subsidiary as capital guarantee under *sharikah*, is not allowed (Bakar, 2007). For El-Gari, what matters in the relationship between corporate groups is the management not the shareholding ownership (El-Gari, 2015a). According to Al-Qarahdaghi, although both parent and subsidiaries are considered as strangers due to the legal features of separate legal personality and limited liability, if the ownership of parent in the subsidiary is one hundred percent, the former is prohibited to provide guarantee to the latter (Al-Qarahdaghi, 2007).

6.0 LEGAL CONCEPT OF CORPORATION AND ITS CORPORATE GROUPS IN QATAR COMPANY LAW

The matters and affairs of business organization in Qatar is governed under its company law statute, namely the Commercial Company Law No. 11 of 2015 ("Law") which was revised in 2015. Article 2 of the Law states that a commercial company is an agreement under which two or more natural or legal persons commit to contribute to a profit-generating project, by way of providing capital or work and sharing the profit generated or loss sustained from the project. Next, holding companies are governed under Chapter 9 of the Law. Article 264 defines holding company as a shareholding company or a limited liability company that financially and administratively controls a company or other companies affiliated to it by owning at least (51%) of the shares or stocks of such companies, whether they are shareholding companies or a limited liability companies. Article 267 of the Law provides that: The objects of a holding company shall be as follows:

- 1- Participating in the management of its affiliates or companies in which it participates.
- 2- Investing its money in shares, bonds and securities.
- 3- Providing the necessary support for its affiliates.
- 4- Owning intellectual property rights, including patent rights, trademarks, industrial models, royalties and other moral rights, and utilising and licensing them for the affiliates or third parties whether inside or outside the State.
- 5- Owning movables and real estate required for carrying out its business within the limits permitted by law.

Article 269 enunciates that a holding company shall take the necessary actions to ensure that its affiliates are maintaining the accounts that enable the members of the board of directors or the managers of the holding company to verify the financial statements and the profit and loss account have been completed in accordance with the provisions of this law. The holding company shall, at the end of each financial year, set up a consolidated balance sheet, profit and loss account and cash flows for itself and all of its affiliates, and shall present them to the general assembly in addition to clarifications and details relating to them according to internationally accepted accounting and audit practices and standards. Article 270 stipulates that this holding company applies to both kinds of *sharikah* namely *sharikah al-musahamah* and limited liability company (*sharikah dzat al-masuliyah al-mahdudah*).

7.0 OBSERVATION

It is observed from the above discussions that the group of companies strictly remains as a separate legal entity distinct from its members be them individually or corporations and hence, their liabilities are separated by way of limited liability principle. The relationship between a parent and its subsidiaries or affiliates renders different legal entities altogether despite they relate to each other by way of shareholding ownership and controlling interest structures. In fact, mere ownership of shares is not sufficient to constitute these group of companies as a single economic entity. By virtue of these fundamental legal principles, creditors of a subsidiary cannot sue its parent should the former fail to satisfy their debt claims. However, this may only be done so by the court in lifting their corporate veils to burden the subsidiary's debt claim by the creditors on its parent or vice versa provided that the litigants could prove their corporate managements and internal affairs are practically run within a single economic unit by way of partnership, or the subsidiary acts as an agent on behalf of the parent as its principal through agency

relationship. The case of *DHN Food Distributors Ltd v Tower Hamlet London Borough Council* proves this concept where the group of companies were held as an economic unit entity by way of partnership. This is however distinguished by *Adams v Cape Industries PLC* where merely invoking the single economic unit will breach the fundamental principle of separate legal personality of company within its corporate group. This apparently shows that corporation will never be considered as a partnership or aggregate of individuals since both are different entities under the common law.

Sharikah on the other hand is an aggregate of individuals between its partners. Their relationship remains contractual rather than statutory. The *sharikah* is built upon *wakalah* contract between the members whereby they represent themselves as a single entity in acting on their respective behalf in any act, business, transaction or management. There is basically no separation between ownership and management control since they are given equal rights and entitled to participate in the business management. Nonetheless, such separation may occur in *al-mudharabah* contract except that the latter does not divide between both ownership and control because any act, conduct or decision making in the business performed by the *mudharib* must be subjected to the *rabbul mal's* consent since he is the capital provider of the *al-mudharabah*. This is different from corporation where the capital belongs to the company and the board of directors can decide whatever they wish for such capital even though such action would affect the shareholders' consent. In addition the partners typically share in capital, profit, assets and liabilities respectively. This is obviously justifiable since it does not have separate legal personality distinct from them. Indeed, they will be collectively entitled for any interests and jointly and severally liable for any liabilities in the *sharikah* entity.

Generally, the recognition of *sharikah al-musahamah* as well as *sharikah al-qabidhah* under the Shariah concept of *sharikah* by the contemporary Muslim scholars would be inaccurate since both corporation and *sharikah* are different in terms of definition, attributes, purposes and structures. In addition, the application of *sharikah* principles into these conventional corporate structures, particularly those registered under the CA 2016 would lead to confusing results since under the common law, group of companies is always regarded as separate legal entities distinct from its corporate members by way of limited liability. Meanwhile, *sharikah* under Shariah is always a contractual partnership agreement between its partners who share joint rights, liabilities and responsibilities in the *sharikah* entity. Basically from Shariah perspective, there is no concept of corporate group in *sharikah* since the latter's fundamental is always contractual rather than the corporate form of legal personality. Moreover, the concept of subsidiary in *sharikah* differs from the concept in common law. This is supported by Al-Qarahdagh's view that the branches of *sharikah* differs from the concept of subsidiary under common law in that the former lacks legal personality and still originated from original *sharikah* (Al-Qarahdagh, 2007). The study observes that at the very least *sharikah* is parallel to agency-relationship and single economic unit as among the grounds for veil piercing of the corporate groups. Be that as it may, such concept is an exception to the general rule of limited liability whereas the court would only apply it based on factual circumstances of each case and its merits. Several scholars attempted to argue that majority control in the management by of way fifty-percent shareholding ownership would suffice to constitute both parent and its subsidiary as a related parties or single entity under *sharikah* and hence must observe the *sharikah* principles for example the parent cannot guarantee the subsidiary's capital based on *sharikah* principle. However, the study observes that they did not address whether this view would impliedly apply to the parent's liability against the subsidiary's debts as would happen in veil piercing. This is addressed by El-Saadouni who viewed that decisive influence would be suffice to attribute the parent's liability to the subsidiary's debts if the former exercised such control (El-Saadouni, 2013).

Under the Qatar company law, a corporation is defined as an agreement between two or more members in share of capital and profit which constitute a *sharikah*. Interestingly, the concept of holding company and its subsidiaries is more structured in such a way that resemble partnership. This is proved by its several provisions which clearly state that a holding company can participate in the subsidiary's management and can own assets in the latter. This is likely parallel to the definition of shares given under Article 3/1, Shariah Standards No. 21: Financial Paper (Shares and Bonds) of AAOIFI which states that "share represents an undivided share in the capital of a corporation, just as it represents an undivided share in its assets and the rights associated with it upon conversion of the capital into tangible things, benefits, debts and so on" (AAOIFI, 2015), applicable to both corporation and corporate group level. This definition is given mainly because the contemporary Muslim scholars equate corporation with *sharikah al-inan* as highlighted above. Having said that, such definition is inconsistent with the legal definition of shares of corporation under the common law whereby Farwell J held in *Borland's Trustee v Steel Brothers & Co Ltd* [1901] 1 Ch 279 that shares is the interest of the shareholder in the company measured by a sum of money and made up of various rights contained in the contract. In *Public Bank Bhd v. New Age Digital Print Sdn Bhd & Anor* [2019] 5 CLJ 1, Rohana Yusuf FCJ held that by virtue of separate legal entity and limited liability, the shareholders do not have any legal and equitable rights over the corporation's assets.

8.0 CONCLUSION

This study attempts to highlight that any group of companies registered under the CA 2016 conducting Shariah compliant business activities should adhere to the principles of *sharikah* for their corporate business compositions and not the other way around. This is because Shariah highly emphasizes on the contractual agreement between the partners rather than the legal structure of business entity like corporation that is originally conventional in ensuring its compliance to the Shariah principles relating to business organization like *sharikah*. At the very least, the contemporary Muslim scholars had significantly attempted to discuss the concept of group of companies under the category of *sharikah* from Shariah perspectives. However, such discussion still remains superficial which requires more scrutiny to the legal structure of group of companies for further deliberation from Shariah perspectives. In developing the legal framework for Shariah compliant group of companies in Malaysia, reference to the corporate organisation of *sharikah* in the Qatar company law is essential which aims to review on to the extent the concept of *sharikah* is applied into the legal structure of group of companies. This would be a good preliminary start to further venture into this research study in the future.

REFERENCES

- Abd Ghasas, Z. A., & Engku Ali, E. R. A. (2012). The Development of Partnership Based Structure In Comparison To the Concept of Musharakah (Sharikah) with Special Reference to Malaysia. *Journal of Islam in Asia* (E-ISSN: 2289-8077), 8(2), 293–315. <https://doi.org/10.31436/jia.v8i0.248>
- Abu Ghuddah, A. A.-S. (2004). Al-Sharikat Al-Hadithah, Al-Sharikat Al-Qabidhah Wa Ahkamuha Al-Shari'yyah. In *Majallat Majma' Al-Fiqh Al-Islami Li Mu'tamar Majma' Al-Fiqh Al-Islami*. Vol 2.,
- Accounting and Auditing Organization for Islamic Financial Institutions (AAOIFI). (2015). *Shariah Standards for Islamic Financial Institutions*. Dar Al-Maiman for Publishing and Distributing.
- Al-Hujailani, A. A. M. A. (2002). *Tasarrufat Al-Amin Fi Al-Uqud Al-Maliyyah* (1st edn). Vol 1, Majallah Al-Hikmah, Great Britain.
- Al-Khalil, A. M. (2002). *Al-Ashum Wa Al-Sanadat Wa Ahkamuha Fi Al-Fiqh Al-Islami* (1st edn). Dar Ibn Al-Jawzi.
- Al-Khayyat, A. A. (2004). Al-Sharikat Al-Qabidhah Wa Ahkamuha Al-Syari'yyah. In *Majallat Majma' Al-Fiqh Al-Islami Li Mu'tamar Majma' Al-Fiqh Al-Islami*. Vol 2.
- Al-Qarahdagi, A. M. A. (2007). Al-Sifat Al-Mu'thirah Fi Al-'Ilaqah Baina Al-Sharikat. In *Hawliyyah Al-Barakah, Majallat A'maliyyah Mutakhassisah Bi Fiqhi Al-Mua'malat Wa Al-'Mal Al-Masrafi Al-Islami*. Majmua'h Dallah Al-Barakah Al-Amanah Al-A'mah Li Al-Haiyah Al-Shariyyah.
- Al-Soifi, A. A. (2006). *Al-Sharikat Al-Qobidah Wa Ahkamuha Fi Al-Fiqh Al-Islami* (1st edn). Dar Al-Nafais.
- Al-Za'atari, I. A.-D. (2012). *Mawsua'h Fiqh Al-Mua'malat Al-Maliyyah Al-Muqoron*. Dar Al-Usoma'.
- Bakar, M. D. (2007). Al-Sifat Al-Mu'thirah Fi Al-'Ilaqah Baina Al-Sharikat. In *Hawliyyah Al-Barakah, Majallat A'maliyyah Mutakhassisah Bi Fiqhi Al-Mua'malat Wa Al-'Mal Al-Masrafi Al-Islami*. Majmua'h Dallah Al-Barakah Al-Amanah Al-A'mah Li Al-Haiyah Al-Shariyyah.
- Dix, M. J. (1953). The Economic Entity. *Fordham Law Review*, 22(3). <https://ir.lawnet.fordham.edu/flr>
- El-Gari, M. A. (2015a). *Al-Shakhsyiyah Al-'Itibariyyah Dzāt Al-Ghard Al-Khas*.
- El-Gari, M. A. (2015b). Al-Takyif Al-Fiqhi Li Ashum Sharikat Al-Musamaham. *6th Shura Fiqh Conference 2015*. <http://shura.com.kw/conferenceDesc.asp?pageID=21&confID=27>
- El-Saadouni, R. (2013). *The Liability of Groups of Companies in Islamic Law (A Comparative Study with Common Law)* (Issue November). University of Stirling.
- Haikal, S. O. (2019). Re-Examining the Structure of Firms and the Provision of Finance: The Case for Islamic Partnerships. *Asian Social Science*, 15(10), 64. <https://doi.org/10.5539/ass.v15n10p64>
- Levenberg, P. N. (2019). The Mystery of the Corporate Veil: Comparing Anglo-American Jurisdictions. *Penn State Journal of Law & International Affairs*, 7(1), 115.
- Lipton, P. (2014). The Mythology of Salomon's Case and The Law Dealing with The Tort Liabilities of Corporate Groups: An Historical Perspective. *Monash University Law Review*, 40, 452.
- MASB Standard 12 Investments in Associates, 1 (2000) (testimony of Malaysian Accounting Standards Board).
- Meng, C. W. (2017). *Essential Company Law in Malaysia, Navigating The Companies Act 2016*. Thomson Reuters.
- Mohd Sulaiman, A. N., & Othman, E. (2018). *Malaysia Company Law: Principles and Practices* (2nd edn). Wolters Kluwer.
- Muhammad Nur, `Ali. (2019). Al-Takyif Al-Fiqhi Li Sharikah Al-Musamaham wa Ashumiha. *8th Shura Fiqh Conference 2019*.
- Murali, K. M., & R. A. (2018). A Study on The Concept of Juristic Personality. *International Journal of Pure and Applied Mathematics*, 120(5), 99.
- Nyazee, I. A. K. (2006). *Islamic law of Business Organization: Partnerships*. The Other Press.
- Nyazee, I. A. K. (2010). *Islamic law of Business Organization: Corporations*. Adam Publishers & Distributors.
- Petrin, M., & Choudhury, B. (2018). Group Company Liability. *European Business Organization Law Review*, 19(4), 771–796. <https://doi.org/10.1007/s40804-018-0121-7>
- Rachagan, S., Pascoe, J., & Joshi, A. (2010). *Concise Principles of Company Law in Malaysia* (2nd edn). LexisNexis Malaysia.
- Sadique, M. A. A.-R. (2009). *Essentials of Musharakah and Mudarabah: Islamic Texts on Theory of Partnership*. IIUM Press.
- Sano, Q. M. (2004). Al-Sharikat Al-Hadithah Al-Sharikat Al-Qabidhah Wa Ahkamuha Al-Shari'yyah. In *Majallat Majma' Al-Fiqh Al-Islami Li Mu'tamar Majma' Al-Fiqh Al-Islami* (14th sess). Vol 2.,
- Wizarah Al-Awqaf wa Al-Shuun Al-Islamiyyah Kuwait. (1992). *Al-Mawsu'ah Al-Fiqhiyyah* (1st Edn). Vol 26.

THE EFFECT OF INTELLECTUAL CAPITAL ON FINANCIAL PERFORMANCE: EMPIRICAL EVIDENCE FROM SHARIAH COMPLIANT CONSTRUCTION FIRMS IN MALAYSIA

Mohamad Nizam Jaafar^a, Amirul Afif Muhamat^b Norzidah Abdul Karim^c Wan Shah Shahdila-Shahar^d

^aArashad Ayub Graduate Business School, Universiti Teknologi MARA, Shah Alam, Malaysia

^{b,c} Faculty of Business Management, Universiti Teknologi MARA, Selangor

^dInternational Islamic University College Selangor, Malaysia

ABSTRACT

The aim of this empirical study is to investigate the impact of intellectual capital (IC) on the financial performance of shariah compliant construction firms listed on Bursa Malaysia Berhad. This study quantity IC by the value added Intellectual coefficient model. A regression analysis was applied to evaluate the impact of IC on financial performance. Panel data from 40 Shariah compliant construction companies in Malaysia were analyzed for duration of 5 years (2014-2018). Nevertheless, the results do not support the hypothesis that IC has significant impact on the financial performance of shariah compliant construction firms. This indicate financial performance of Shari'ah compliant construction firms in Malaysia were not affected by intellectual capital investments. However, the findings show capital employed (CE) has a positive significant relationship with firm performance and significant negative relationship with human capital (HC). The study also reveals that structural capital efficiency (SC) has an insignificant impact on the financial performance of the construction firms. This finding help construction firms manager and investors to understand how to use their IC efficiently especially SC as it is yet to be used efficiently. Also, the findings benefit the relevant authorities (e.g. legislators and securities commission) who could use them to emphasize strategic policy reforms whenever required. This study also adds value to existing knowledge regarding IC.

Keywords – Construction firms, Intellectual Capital, Islamic capital market, Panel Data, Shariah compliant, VAIC

1.0 INTRODUCTION

The relationship of intellectual capital and financial performance is being governed by resource-based theory where firm resources as the main drive behind competitiveness and firm performance. However, according to Barney (1991), not all firms' resources have the capabilities of becoming a source of competitive advantage. Belkaoui (2003) argued that these resources can be classified into two categories namely tangible and intangible resources. According to Barney (1991), tangible resources include physical technology used in a firm, a firm's plant and equipment, its geographic location and its access to raw material. Meanwhile, intangible resources refer to human capital and organizations capital. Human capital resources include the training, experience, judgement, intelligence, relationships and insight of individual managers and workers in a firm.

With the rapid shift toward knowledge economy, the source of economic value has now depended on the creation of Intellectual capital. According to Barney (1991) intellectual capital can be described as the portfolio of a firm's resources that assist in enhancing their sustainable values. This is supported by Chen et al (2005), Guthrie et al, (2006) that organizations are increasing dependent on IC to achieve the financial performance and growth objective. Nevertheless, IC is often not properly recorded in financial account of the firms that resulting to incorrect estimation on the actual worth value of firms especially among firms with high IC resources (Petty and Gurthrie, 2000). This is further supported by Edvinsson and Malone (1997), the financial statements derived from actual accounting standards does not deliver to the managers the necessary information. Thus, it is difficult to predict or evaluate the company's future financial performance, and its value creating factors. Consequently, the usage of financial statements which "hide" the intangibles can result to wrong decision making. Thereby firms are expose to losing risk valuable competitive advantage (Yang and Lin, 2009; Ousama, Hammami and Addulkarim, 2019). In order to create a long term competitive advantage, the efficient creation of IC is required in knowledge base economy. Several firms started to realize the important value of IC as one of important components of their firm's sustainability (Marshall et al., 2006; Borkowski et al., 2010). Strategically, this is very crucial for high capital

intensity firms requiring knowledge and skilled human resources such as those required in the construction sector. To attain their desired objectives and ensure competitive success, construction firms are expected to provide high-quality services by investing in the training of their human resources, systems and processes as implemented by other sectors such as financial service industry (Goh, 2005; Ahuja and Ahuja, 2012).

Despite of the rising investment in tangible in the knowledge base economy firms, there is still limited coverage conducted on certain areas of intangible assets. There are numerous of researches investigated the efficient use of IC in financial sector (Goh, 2005; Shih et al., 2010; Ousama and Fatima 2015; Ousama et al., 2019) but there are still limited research focus on other industries such as constructions, manufacturing and etc. (Ousama et al., 2019). The goals of knowledge based firms, including construction, can only be achieved by using all their resources (tangible and intangible/intellectual). Hence, it is essential to observe whether the other sector is using its IC effectively and is henceforth able to contribute to the growth in the new economy set up.

Therefore, this study wants to investigate the impact of IC on shariah compliant construction firms in Malaysia. The construction industry plays important part in Malaysia economy because it has impact on every industry that linked to it. The sector has been the major contributor to the GDP's growth through its' revenue, capital formation and employment. The contribution from the construction sectors no doubt has been providing the infrastructure for industrial growth, production and basic amenities such as ports, power generating, railways, as well as the other basic infrastructure which give benefit to society and country (Malaysia Economic Planning Unit, 2018).

The study measures IC efficiency by using the value added intellectual coefficient (VAIC) model and investigates the relationship between IC efficiency (i.e. VAIC) and financial performance. Examining the IC in this industry should add to the existing knowledge on the relationship between IC and construction firms' performance. Secondly, the findings help construction industry firms self-assess their level of resource efficiency and improve performance. Further, it constitutes an additional layer of scrutiny of the health of the firms.

The remaining of the paper is organized as follows. Section 2 presents an overview of the construction industry in Malaysia. Section 3 highlights the prior literature and develops the hypotheses. Section 4 details the research method. Section 5 discusses the results, while Section 6 concludes this research.

2.0 MALAYSIA ECONOMY AND CONSTRUCTION INDUSTRY

Malaysia had experienced stable growth in economy from economy based on agriculture in 1970s to industrial in 1980s under the twenty years plan from 1970 to 1990 (Malaysia Economic Planning Unit, 2018). The government realizes that the main factor of the country's economic growth is due to one of the primary components of intellectual capital which is human capital especially during the industrialization period. As a result, human resources process begun had been develop by the government to stabilize the economic growth and remain competent within the global market.

Starting from the 1st Malaysia Plan until the 11th Malaysia Plan (2016-2020), human capital has been emphasized. As an example, shifting the economy growth from the input driven to knowledge driven economy has been emphasized during the Malaysia's Eighth Development Plan. Further, the plan also focusing by increasing the human resources development on productivity and efficiency. It also focusing on increasing R&D as well as utilizing the latest technologies especially information communication technologies (ICT). Furthermore, to proof that its strategy is reliable, investment in human capital had been one of the agendas in Ninth Malaysia. Therefore, in enhancing the national productivity as well as growth through developing the efficiency and talented workforce are the aim of the Ninth Malaysia Plan. Even though, under the Malaysia Plan until 2020, it will be challenges for Malaysia since it still in middle-income trap and to achieve to the high-income level, therefore the government is putting the emphasis on the human capital development. This could observe in the allocation for the physical development is been reduced from 78% (9th Malaysia Plan) to 60% (10th Malaysia Plan) due to the realization of the government on the importance of human development and to improve standards of living. Under 10th Malaysia Plan, more focus on non-physical projects are been allocated more than physical projects as compared to in 9th Malaysia Plan whereby from 22% to 40%. The vision 2020 had set a target that Malaysia need to be productive and innovative to drive the economy by setting a new and higher goals and changed the behavior of Malaysia. The agenda of human capital development still continuously become an agenda in 11th Malaysia Plan (2016-2020) whereby to produce the human capital with the right knowledge, skills and attitudes in order to thrive in a globalized economy.

2.1 The Important Of Construction Sector

The choice of selecting construction firm in this study is motivated by few studies conducted. Construction sectors are also playing a role or had contributed in gross domestic product (GDP) for countries regardless developed and developing countries (Myers, 2013). Ives and Grunberg (2000) through generation of capital structure by construction sectors which are from investment will create the sustainable of economic development. Construction companies can be treated as one of the key industries that boosts the economy of Malaysia. The industry's activities linked to many various phases of economic development thus making constructions more significant to the growth of the economy. It is expected that through the 11th Malaysia Plan, 5.5% of GDP growth will be contributed from this industry in year of 2020.

3.0 LITERATURE REVIEW

There are various of studies have been conducted on IC for several decades (Ousama et al., 2019). The areas of studies include the definition of IC, formulation and its appropriate reporting, among others (Guthrie et al., 2006; Kamath, 2008; Striukova et al., 2008). In addition, there are also other advance studies conducted on IC such as determinants of IC disclosure (White et al., 2007; Whiting and Woodcock, 2011), relationship of IC on performance (Nik Maheran, 2009; Nimtrakoon, 2015; Ting and Lean, 2009), influence of IC disclosure on market value (Ousama et al., 2011b) and effectiveness of IC information (Ousama et al., 2011a) have also been empirically studied. As such various accounting models and structures for IC measurement have been established (Guthrie et al., 2007). These frameworks comprise of direct IC methods, market capitalisation methods, firm performance methods and scorecard methods (Sveiby, 2007). The growing number of frameworks stems from the need to reflect the market value of companies in their financial reports (Guthrie et al., 2007).

Considering various research have been conducted on IC, this indicate importance of IC (Marr et al., 2003). IC is a measurement metric in evaluating firm performance using traditional balance sheets and income statements to compare the return of assets between different firms (Guthrie et al., 2007; Bhartesh and Bandyopadhyay, 2005). This approach relies on historical data to compute IC. Iazzolino and Laise (2013) highlighted that over the last three decades, there was more innovated methods to measure IC such as VAIC, economic value added (EVA), human resource accounting, and value chain scoreboard.

Furthermore, the result of past has indicated mixed outcomes between intellectual capital and firm performance. For instance, studies by (Nik Maheran, 2009; Nimtrakoon, 2015; Ting and Lean, 2009) acquired positive relationship. On the contrary, a few researches recorded negative connection between intellectual capital and banking sector (Bontis et al., 2015; Joshi et al., 2013; Kamath, 2007; Maditinos et al., 2011; Mehralian et al., 2012; Mosavi et al., 2012). In addition, the greater part of the exploration on intellectual capital is led in created nation and for the most part in banking area (K. S. Adesina, 2019; El-Bannany, 2008; Goh, 2005; Joshi et al., 2010; Kamath, 2007; Meles et al., 2016; Oppong and Pattanayak, 2019)

Similarly, (Nimtrakoon, 2015) study on the relationship between intellectual capital and financial performance of technology firms on the five ASEAN stock for the year 2011. The result suggested a positive relationship between intellectual capital and financial performance. In contrast, some studies documented a negative relationship between intellectual capital and firms' financial performance. According to Kamath (2007) studies on the pharmaceutical firms in India and documented a negative relationship between intellectual capital and financial performance. The same negative relationship was documented in a study involving Serbian hotel industry (Janosevic, Dzenopoljac, & Bontis, 2013) The findings showed that the financial performance of hotels in Serbia were influenced mainly by efficient use of physical capital rather than intangible capital.

4.0 THEORETICAL FRAMEWORK AND HYPOTHESES STATEMENT

In order to carry out this research, descriptive analytical research designs were employed. Both descriptive and analytical research design used. There are 40 shariah compliant companies listed under construction sector in the main market from the period of 2014 until 2018. To determine the relationship between each independent variable and dependent variable, model develop based on empirical findings aid by Econometric Views 9

Theoretical framework describes the relationship between the independent variables and dependent variable. In this study, researchers are using two theoretical framework as per illustrated in figure 1 (Model A) and figure 2 (Model B). The dependent variable used in this study is return on asset and the selected independent variables are HCE, SCE, CEE and VAIC.

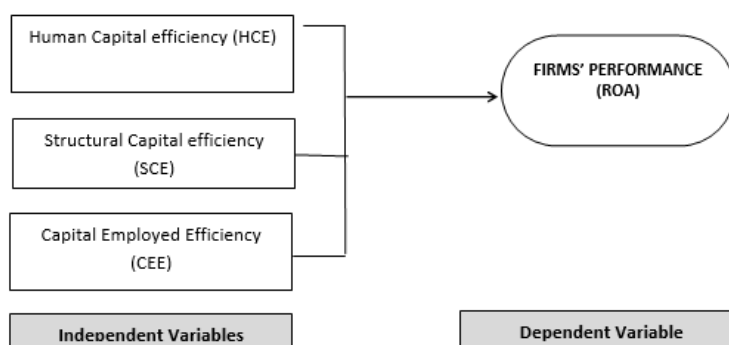

Figure 1: MODEL A



Figure 2: MODEL B

4.1 Hypothesis Statements

The frame work for this study as depicted in Figure 1 shows that IC influences corporate performance. The solid line represents the relationship between the IC (i.e. VAIC) and financial performance. The lines represent the relationships between IC components, i.e. Capital employed efficiency(CEE), HCE, SCE and financial performance.

Accordingly, the following hypothesis is developed to test the relationship between IC and financial performance:

H_1 = There is a significant relationship between HCE and firm's ROA.

HCE plays a great role in a firm's value creation (Holland, 2003) and investors incorporate the HCE information into their firm valuation processes.

Goh (2005) measured the IC performance of commercial banks in Malaysia for the period of 2001 to 2003. The result showed that value creation capability of commercial banks in Malaysia is largely attributed to human capital efficiency (HCE). The findings of Ozkan et al. (2016) suggest that the IC of the Turkish banking sector is mainly affected by HCE. Mondal and Ghosh (2012) reached a similar result in India. Gan and Saleh (2008) and Chu et al. (2011) found that HC plays a major role in enhancing the returns of banks

H_2 = There is a significant relationship between SCE and firm's ROA.

SCE have a positive relationship with firm's profitability as SCE offer a conducive platform which help an organisation to develop and influence knowledge (Nawaz, 2017). An organisation with good SCE set up promote an innovative environment (Florin et al., 2003). It is argued that SCE has a significant impact on performance (De Brentani and Kleinschmidt, 2004).

H_3 = There is a significant relationship between CEE and firm's ROA.

Several empirical research conclude that CEE has a positive significant effect on organisational financial performance (Chen et al., 2005; Chan, 2009a, 2009b). However, other prior studies in Turkey, Malaysia and Australia found that the CEE was less effective in creating value in the banking sector (Goh, 2005; Joshi et al., 2010; Ozkan et al., 2016).

4.2 Variables And Methods Of Computation

TABLE 1: Firm's Specific Factor, Accounting Indicators, Measurement

Variable	Accounting indicators	Measurement
Performance	Return on Asset (ROA)	Net Profit After Tax Total assets
Intellectual Capital	Human Capital Efficiency (HCE)	Value Added (VA) Human Capital (HC)
Intellectual Capital	Structural Capital Efficiency (SCE)	(VA - HC) VA
Intellectual Capital	Capital Employed Efficiency (CEE)	VA Capital Employed CE
Intellectual Capital	Value Added Intellectual Coefficient (VIC)	HCE + SCE + CEE

5. EMPIRICAL ANALYSIS

5.1 Descriptive Analysis

TABLE 2 : Descriptive Statistic

	ROA	HCE	SCE	CEE	VAIC
Mean	3.166885	4.751562	0.738863	0.125555	5.599742
Median	3.743800	3.348400	0.727550	0.104850	4.246250
Maximum	18.49120	138.3481	9.979700	1.027800	140.3510
Minimum	-21.65860	-5.528700	-1.137000	-0.126400	-4.399600
Std. Dev.	6.176472	10.51139	0.803314	0.128089	10.64370
Skewness	-0.689542	10.67931	7.995455	3.823895	10.57525
Kurtosis	4.749411	133.1138	90.62932	25.69079	131.1489
Jarque-Bera	41.35258	144881.5	66121.72	4778.004	140578.9
Probability	0.000000	0.000000	0.000000	0.000000	0.000000
Sum	633.3770	950.3124	147.7725	25.11100	1119.948
Sum Sq. Dev.	7591.612	21987.37	128.4175	3.264966	22544.38
Observations	200	200	200	200	200

Table 2 shows the descriptive information of profitability (ROA) and 3 independent variables for 40 shariah compliant listed companies for 5 years' period from 2014 to 2018. Based on the above result, the mean value for profitability (ROA) is 3.166 which indicates that overall, the ROA for the Shari'ah compliant construction companies listed on Bursa Malaysia is not that high but still able to generate profit in the period of analysis. In terms of HCE, the indicator of value added by the human resources employed by the firm, the mean was measured at 4.7515 times. This shows that, on average the companies were able to generate their income about 4 times with every unit of human capital employed. Out of the three components of IC, it can be seen that HCE recorded the highest mean and this shows that investment in HCE will recorded the highest payback as compared to other intellectual capital

4.2 Correlation Analysis

The results of correlation analysis are shown in Table 3 for *Shariah* compliant construction sector. Correlation analysis was conducted to examine the relationship between all the variables in this study and the matrix used shows the strength relationship among the variables.

TABLE 3: Pearson Correlation Matrix

Variables	ROA	HCE	SCE	CEE	VAIC
ROA	1.000000				
HCE	0.016987 (0.8113)	1.000000			
SCE	-0.010730 (0.8801)	0.028665 (0.6870)	1.000000		
CEE	0.248290 (0.0004)***	0.639004 (0.0000)***	-0.091858 (0.1958)	1.000000	
VAIC	0.017642 (0.8042)	0.997073 (0.0000)***	0.103097 (0.1463)	0.634642 (0.0000)***	1.000000

Note: ***, **, * denotes significance at 1%, 5%, 10% respective

Based on Table 3, it is found that the correlation value indicated significant and positive associations between CEE and ROA only. CEE was correlated with ROA at $\alpha = 0.01$, HCE at $\alpha = 0.01$ and VAIC $\alpha = 0.01$ but it is not correlated with SCE. In the correlation analysis, the correlation value which is more than 0.9 will lead to multicollinearity problem existing in the sample data (Asteriou & Hall, 2015). Therefore, it can be concluded that there was no multicollinearity issue in the sample data for 40 Shari'ah compliant construction companies listed in Bursa Malaysia.

4.3 Choosing The Best Model

4.3.1 Likelihood Ratio Test

Likelihood Ratio Test is applied in this study to choose the best model between Pooled Ordinary Least Squares (POLS) model and Fixed Effects Model (REM). The hypotheses under Likelihood Ratio Test are as follows:

H_0 = POLS model is preferred

H_1 = Fixed Effects Model is preferred

Table 4: Likelihood Ratio Test

Effects Test	Statistics (P-Value)
Cross-section F	4.925109 (0.0000)***
Cross-section Chi-square	158.810642 (0.0000)***

Based on Table 4, p-value of cross-section F and cross-section Chi-Square statistics were 0.0000. Thus, the results are showed that statistically significant since the p-value is less than $\alpha = 0.01$. This can be concluded that the null hypothesis in Likelihood Ratio Test is rejected and that the Fixed Effects Model (FEM) is preferred.

4.3.2 Hausman Test

There are two types of models that may be applied in this study which are Fixed Effects Model (FEM) and Random Effects Model (REM). When Likelihood Ratio Test shows that FEM is preferred, then the Hausman Test must be conducted to select whether FEM or REM are preferred in this study. The hypotheses statement are as follows:

H_0 = Random Effects model is preferred

H_1 = Fixed Effects model is preferred

Table 5: Hausman Test

Test Summary	Statistics (P-Value)
Cross-section random	0.000000 (1.0000)

According to Table 5, p-value for cross-section random statistics for *Shariah* compliant construction companies was 1.0000. Since the p-value exceed than $\alpha = 0.05$, then the alternate hypothesis was rejected and accepts null hypothesis. Then, it concluded that Random Effects model is preferred.

Table 6: Random Effects Model A

Variables	Coefficient	t-statistics	(P-Value)
HCE	-0.086376	-0.813318	0.0902***
SCE	0.044015	-0.865196	0.9200
CEE	11.70325	1.804802	0.0088***
C	2.075382	3.242237	0.0014***
F-Statistics		5.462892 (0.00000)***	
Adjusted R-Squared		0.485045	
Durbin Watson		1.978084	

Note: *** denotes significance at 1%

Table 7 : Random Effect Model for model B

Variables	Coefficient	t-statistics	(P-Value)
VAIC	0.001169	0.030220	0.9759
C	3.160338	8.207491	0.0000***
F-Statistics		5.389379 (0.000000)***	
Adjusted R-Squared		0.468791	
Durbin Watson		2.100686	

Note: *** denotes significance at 1%

5.0 FINDING

The finding shows that CEE portrays the most influential variable that affects the performance of the Shari'ah compliant construction firms in terms of profitability as it has the highest coefficient as compared to other variables. The results imply that the greater the CEE value the greater the profitability of the companies. This proves that the total amount of capital employed in the company is vital and paramount in determining the firms' performance. To explain further, Shariah compliant construction companies may get positively affected by the greater amount of capital employed.

For Human Capital Efficiency (HCE), it was found that it is statistically significant at 10% significance level which negative impact to firms' ROA. Structural Capital Efficiency (SCE) and VAIC were found to be statistically insignificant determinant of the ROA for 40 Shari'ah compliant construction companies which listed in Bursa Malaysia. For HCE, the results explain that greater investment in human capital will negatively affect the ROA for the firms. This can be understood as construction industries are heavily relied on machines and equipment as compared to human force. For SCE, the results show that the firms' intellectual property such databases and software and the knowledge stored in the company are not really important factors in determining the profitability of the Shari'ah compliant construction companies. To add, the intellectual capital as proxy by VAIC is also to be found not a vital aspect to drive the ROA of the Shari'ah compliant construction companies which listed in Bursa Malaysia as found by the results of this study. The result is supported by the theory of intellectual capital which is also known as Resourced-based Theory (RBV) (Daft, 1992). CEE is the most influential component of intellectual capital among other independent variables namely HCE, SCE and VAIC.

TABLE 8 : Summary of the Results

Independent Variables	Results	Relationship
HCE	Significant	Negative
SCE	Insignificant	Negative
CEE	Significant (1% level of significance)	Positive
VAIC	Insignificant	Positive

6.0 CONCLUSION AND RECOMMENDATION

Conclusively, since the construction firms become fast growing sectors for the past few years as reported in the Malaysia Plan, therefore, the construction sectors should consider to concentrate on the IC driven factors. By enhancing the firms' knowledge in IC and increase the ICs' utilization would lead to enhancement of firms' performance. Derived from this study's result that also showed human capital efficiency would affect the firms' performance therefore efficient human capital cost management should be taken into firms' consideration in order to improve their financial performance. Then, the sector will continue in contributing to Malaysia's GDP in the coming years. This study also will create opportunity for the firms to evaluate the contribution of IC in order to design better business strategies.

In addition, the findings revealed that construction firms gain greater benefit from financial and physical capital in relation to structural capital, therefore increasing investment in physical capital may lead to even higher profit. By having a strong capital base, it would help the firms to increase profitability at all times. Further, based on past researchers' studies also had questioned on the validity and the Value Added Intellectual Coefficient (VAICs) model suitability. The study mentioned that VAIC model is designed only to measure capital investment and human capital rather than IC. Future researchers should consider other models such as Modified Value Added Intellectual Coefficient (MVAIC) model (Ulum et al, 2014) in order to measure relationship between IC with performance of Shari'ah compliant construction sectors listed in Bursa Malaysia.

The study has several limitations. Firstly, there are 46 shariah compliant construction companies listed on Bursa Malaysia. However, research sample excluded 6 companies due to not meeting our research criteria'. Secondly, the research period is limited to five years. Longer periods would possibly offer more conclusive results. Thirdly, the findings relied on quantitative analysis (regressions) which is insufficient for a rich. Therefore, more qualitative analysis is required (interviews with key decision-makers) to understand the position of IC in the construction industry better.

REFERENCES

- Alipour, M., Mohammadi, M., & Derakhsan, H. (2015). Determinants Of Capital Structure: An Empirical Study Of Firms In Iran. *International Journal of Law and Management*, 57(1), 53-83.
- Andriessen, D. (2006). On The Metaphorical Nature Of Intellectual Capital: A Textual Analysis. *Journal of Intellectual Capital*, 7(1), 93-110.
- Asteriou, D., & Hall, S. (2015). *Applied Econometrics*. USA: Palgrave Macmillan.
- Bamey, J. (1991). Firm Resources And Sustained Competitive Advantage. *Journal of Management*, 17, 99-120.
- Bamey, J. (1991), "Firm resources and sustained competitive advantage", *Journal of Management*, Vol.17No.1, pp.99-120.
- Biase, P., & D'Apolito, E. (2012). The Determinants of Systematic Risk in the Italian Banking System: A Cross-Sectional Time Series Analysis. *International Journal of Economics and Finance*, 4(11), 152-164.
- Belkaoui, A. (2003). Intellectual Capital And Firm Performance Of US Multinational Firms: A Study Of The Resource-Based And Stakeholder Views. *Journal of Intellectual Capital*, 4(2), 215-226.
- Bontis, N. (1996). There's A Price On Your Head: Managing Intellectual Capital Strategically. *Business Quarterly*, 60, 40-78.
- Bontis, N. (1998). Intellectual Capital: An Exploratory Study That Develops Measures And Models. *Management Decision*, 36(2), 63-76.
- Bontis, N., Chua, W., & Richardson, S. (2000). Intellectual Capital And Business Performance In Malaysia Industries. *Journal of Intellectual Capital*, 1(1), 85-100.
- Chan, K., H. (2009a), "Impact of intellectual Capital on organizational performance: an empirical study of companies in the hang seng index (part1)", *The Learning Organization*, Vol.16 No.1 ,pp.4-12.
- Chan, K.,H. (2009b), "Impact of intellectual Capital on organizational performance :an empirical study of companies in the hangseng index (part2)", *The Learning Organization*, Vol.16 No.1, pp.22-39.
- Chen, M., Cheng, S. and Hwang, Y. (2005), "An empirical investigation of the relationship between intellectual capital and firms' market value and financial performance", *Journal of Intellectual Capital*, Vol.6 No.2, pp.159-179.
- Chen, L., Danbolt, J. and Holland, J. (2014), "Rethinking bank business models: the role of intangibles", *Accounting, Auditing and Accountability Journal*, Vol.27No.3, pp .563-589.
- Chu, S.K.W., Chan, K.H. and Wu, W.W.Y. (2011), "Charting intellectual Capital performance of the gate way to China", *Journal of Intellectual Capital*, Vol.12No.2, pp.249-276.
- Celenza, D., & Rossi, F. (2014). Intellectual Capital And Performance Of Listed Companies: Empirical Evidence From Italy. *Measuring Business Excellence*, 18(1), 22-35.
- Cheng, T.-m., Wu, C.-m., Yu, W.-d., & Lin, D.-j. (2017). Correlation Between Intellectual Capital And Business Performance Of Construction Industry-An Empirical Study In Taiwan. *International Journal of Construction Management*, 2331-2327.
- Daft, R. (1992). *Organization Theory and Design*. St Paul: West Publisher Co.
- Department of Statistics Malaysia, O. P. (3 December, 2018). *Department of Statistics Malaysia*. Retrieved from Department of Statistics Malaysia: <https://www.dosm.gov.my/v1/>
- Edvinsson, L. (1997). Developing Intellectual Capital At Skandia. *Long Range Planning*, 30(3), 366-373.
- Firer, S., & Stanbank, L. (2003). Testing The Relationship Between Intellectual Capital And A Company's Performance: Evidence From South Africa. *Meditari Accountancy Research*, 11(1), 25-44.

- Gan, K. and Saleh, Z. (2008), "Intellectual Capital and corporate performance of technology-intensive companies: Malaysia evidence", *Asian Journal of Business and Accounting*, Vol. 1 No. 1, pp.113-130.
- Ghosh, S., & Maji, S. (2015). Empirical Validity Of Value Added Intellectual Coefficient Model In Indian Knowledge-Based Sector. *Global Business Review*, 16(6), 947-962.
- Goh, P. C. (2005). Intellectual Capital Performance Of Commercial Banks In Malaysia. *Journal of Intellectual Capital*, 6(3), 385-396.
- Gujarati, D. (2009). *Basic Econometrics*. India: McGraw-Hill Education (India) Pvt Ltd.
- Horibe, F. (1999). *Managing Knowledge Workers: New Skills And Attitudes To Unlock The Intellectual Capital In Your Organisation*. Toronto: Wiley Publishers.
- Iqbal, A., Hameed, I., & Qadeer, M. (2012). Impact Of Diversification On Firms' Performance. *American Journal of Scientific Research*, 80, 42-53.
- Ive, G., & Gruneberg, S. (2000). *The Economics Of The Modern Construction Sector*. London: Palgrave Macmillan.
- Joshi, M., Cahill, D., Sidhu, J., & Kansal, M. (2013). Intellectual Capital And Financial Performance: An Evidence Of The Australian Financial Sector. *Journal of Intellectual Capital*, 14(2), 264-285.
- Kamath, B. (2008). Intellectual Capital And Corporate Performance In Indian Pharmaceutical Industry. *Journal of Intellectual Capital*, 9(4), 684-704.
- Kamath, B. (2017). Determinants Of Intellectual Capital Disclosure: Evidence From India. *Journal of Financial Reporting and Accounting*, 15(3), 367-397.
- Kaplan, R., & Norton, D. (1996). Strategic Learning & The Balanced Scorecard. *Strategy & Leadership*, 24(5), 18-24.
- Kristandl, G., & Bontis, N. (2007). Constructing A Definition For Intangibles Using The Resource Based View Of The Firm. *Management Decision*, 45(9), 1510-1524.
- Kujansivu, P., & Lonnqvist, A. (2007). Investigating The Value And Efficiency Of Intellectual Capital. *Journal of Intellectual Capital*, 8(2), 272-287.
- Laing, G., Dunn, J., & Hughes-Lucas, S. (2010). Applying The VAIC Model To Australian Hotels. *Journal of Intellectual Capital*, 11(3), 269-283.
- Latif, M., Malik, M., & Aslam, S. (2012). Intellectual Capital Efficiency And Corporate Performance In Developing Countries: A Comparison Between Islamic And Conventional Banks Of Pakistan. *Interdisciplinary Journal of Contemporary Research in Business*, 4(1), 405-420.
- Malaysia Economic Planning Unit, M. o. (3 December, 2018). *Eleventh Malaysia Plan 2016-2020*. Retrieved From Malaysia Economic Planning Unit, Ministry Of Economic Affairs: <http://epu.gov.my/en/rmk/eleventh-malaysia-plan-2016-2020>
- Malaysia, S. C. (3 December, 2018). *Data & Statistics*. Retrieved from Securities Commission Malaysia: <http://www.sc.com.my/data-statistics/>
- Marshall, R., Talbott, J. and Bukovinsky, D. (2006), "Employee empowerment works at small companies, too", *Strategic Finance*, Vol. 88 No. 3, pp. 34-39.
- Marr, B., & Chatzkel, J. (2004). Intellectual Capital At The Crossroads: Managing, Measuring And Reporting Of IC. *Journal of Intellectual Capital*, 5(2), 224-229.
- Md. Mohiuddin, Syed Najibullah, & Shahid, A. (2006). An Exploratory Study On Intellectual Capital Performance Of The Commercial Banks In Bangladesh. *The Cost and Management Journal*, 34(6), 40-54.
- Mention, A.-L., & Bontis, N. (2013). Intellectual Capital And Banking Sector Of Luxembourg And Belgium. *Journal of Intellectual Capital*, 286-309.
- Montgomery, D., Jennings, C., & Kulahci, M. (2015). *Introduction To Time Series Analysis And Forecasting, 2nd Edition*. USA: Wiley Publisher.
- Morariu, C. (2014). Intellectual Capital Performance In The Case Of Romanian Public Companies. *Journal of Intellectual Capital*, 15(3), 392-410.
- Myers, A. (2013). *What Is Behind The Growth In Trademark Filings? An Analysis Of United States Data*. U.S: U.S. Patent and Trademark Office, Office of Chief Economist.
- Nawaz, T. (2017), "Intellectual Capital, financial crisis and performance of Islamic banks: does Shariah governance matter?", *International Journal of Business and Society*, Vol. 18 No. 1, pp. 211-226.
- Nawaz, T. and Haniffa, R. (2017), "Determinants of financial performance of Islamic banks: an intellectual capital perspective", *Journal of Islamic Accounting and Business Research*, Vol. 8 No. 2, pp. 130-142.
- Nguyen, T., Nguyen, P., & Dang, T. (2017). Analyze The Determinants Of Capital Structure For Vietnamese Real Estate Listed Companies. *International Journal of Economics and Financial Issues*, 7(4), 270-282.
- Nik Muhammad, N., & Ismail, M. (2009). Intellectual Capital Efficiency And Firm's Performance: Study On Malaysian Financial Sectors. *International Journal of Economics and Finance*, 1(2), 206-212.
- Nimtrakoon, S. (2015). The Relationship Between Intellectual Capital, Firms' Market Value And Financial Performance: Empirical Evidence From The ASEAN. *Journal of Intellectual Capital*, 16(3), 587-618.
- Nirajini, A., & Priya, K. (2013). Impact Of Capital Structure On Financial Performance Of The Listed Trading Companies In Sri Lanka. *International Journal of Scientific and Research*, 3(5), 2250-3153.
- Ousama, A.A. and Fatima, A.H. (2015), "Intellectual Capital and financial performance of Islamic banks", *International Journal of Learning and Intellectual Capital*, Vol. 4 No. 2, pp. 159-179.
- Ousama, A.A., Fatima, A.H. and Hafiz-Majdi, A.R. (2011a), "Usefulness of intellectual Capital information: prepares' and users' views", *Journal of Intellectual Capital*, Vol. 12 No. 3, pp. 430-445.
- Ousama, A.A., Fatima, A.H. and Hafiz-Majdi, A.R. (2011b), "Effects of intellectual capital information disclosed in annual reports on market capitalization: evidence from bursa Malaysia", *Journal of Human Resource Costing and Accounting*, Vol. 15 No. 2, pp. 85-101.
- Ozkan, N., Cakan, S. and Kayacan, M. (2016), "Intellectual Capital and financial performance: a study of the Turkish banking sector", *Borsa Istanbul Review*, Vol. 20, pp. 1-9.
- Pal, K., & Soriya, S. (2012). IC Performance Of Indian Pharmaceutical And Textile Industry. *Journal of Intellectual Capital*, 13(1), 120-137.

- Petty, R. and Guthrie, J. (2000), "Intellectual capital literature review: measurement, reporting and management", *Journal of Intellectual Capital*, Vol.1No.2, pp.155-176. Pulic, A. (1998). *Measuring The Performance Of Intellectul Potential In Knowledge Economy*. (Presented in 1998 at the 2nd McMaster World Congress on Measuring and Managing Intellectul capital by the Austrian Team for Intellectul Potential).
- Pulic, A. (2000). VAIC - An Accounting Tool For IC Management. *International Journal of Technology Management*, 20(8), 702-714.
- Rachev, S., Hochstotter, M., Fabozzi, F., & Focardi, S. (2010). *Probability And Statistics For Finance*. Now Jersey: John Wiley & Sons, Inc.
- Roos, G., & Roos, J. (1997). Measuring Your Company's Intellectual Performance. *Long Range Planning*, 30(3), 413-426.
- Ryan, M. (1998). *Knowledge Diplomacy: Global Competition And The Politics Of Intellectual Property*. Washington D.C.: Brookings Institution Press.
- Saenz, J. (2005). Human Capital Indicators, Business Performance And Market-To-Book Ratio. *Journal of Intellectual Capital*, 6(3), 374-384.
- Salleh, A., & Selamat, F. (2007). Intellectual Capital Management In Malaysian Public Listed Companies. *International Review of Business Research Papers*, 3(1), 266-278.
- Scaërto, V., Ricci, F., & Scaërto, F. (2016). Intellectual Capital And Firm Performance In The Global Agribusiness Industry: The Moderating Role Of Human Capital. *Journal of Intellectual Capital*, 17(3), 530-552.
- Seddighi, H. (2013). *Introductory Econometrics: A practical approach*. USA: Routledge.
- Sekaran, U., & Bougie, R. (2013). *Research Methods For Business: A Skill-Building Approach*. UK: John Wiley & Sons Ltd.
- Senge, P. (1990). *The Fifth Discipline: The Art & Practice Of The Learning Organization*. London: Random House.
- Sharabati, A.-A., Jawad, S., & Bontis, N. (2010). Intellectual Capital And Business Performance In The Pharmaceutical Sector Of Jordan. *Management Decision*, 48(1), 105-131.
- Shiu, H.-J. (2006). The Application Of The Value Added Intellectual Coefficient To Measure Corporate Performance: Evidence From Technological Firms. *International Journal of Management*, 23(2), 356-365.
- Stewart, T. (3 June, 1991). *Fortune Magazine*. Retrieved from archive.fortune.com: http://archive.fortune.com/magazines/fortune/fortune_archive/1991/06/03/75096/index.htm
- Stewart, T. (2007). *Intellectual Capital:The New Wealth Organizations*. New York: Doubleday Publishing Group.
- Sydlar, R., Haefliger, S., & Prukca, R. (2014). Measuring Intellectual Capital With Financial Figures: Can We Predict Firm Profitability? *European Management Journal*, 32(2), 244-259.
- Trochim, W., & Donnelly, J. (2006). *The Research Methods Knowledge Base*. Ohio: Atomic dog and Cengage learning.
- Ulum, I., Ghozali, I., & Purwanto, A. (2014). Intellectual Capital Performance of Indonesian Banking Sector: A Modified VAIC (M-VAIC) Perspective. *Asian Journal of Finance & Accounting*, 6(2), 103-123.
- White, G., Lee, A. and Tower, G. (2007), "Drivers of voluntary intellectual Capital disclosure in listed biotechnology companies", *Journal of Intellectual Capital*, Vol. 8 No. 3, pp. 517-537.
- Whiting, R. H. and Woodcock, J. (2011), "Firm characteristics and intellectual capital disclosure by Australian companies", *Journal of Human Resource Costing and Accounting*, Vol. 15 No. 2, pp. 102-126.

EFFECTS OF THE BOARD OF DIRECTOR'S CHARACTERISTICS ON ISLAMIC BANKS' FINANCIAL SOUNDNESS

Afef Khalil

Ihec-carthage, University of Carthage, Tunisia

Abstract

The aims of this study is to diagnose the Board of Director's characteristics and its impact on the financial soundness of Islamic banks. Regression analysis are applied to test the effect of the Board of Director's characteristics on the financial soundness of Islamic banking, employing a panel data composed of 67 Islamic banks during the period 2005-2014. The level of Islamic bank soundness is individually using the Z-score indicator. To verify the robustness of results, we use other dependent variables (CAMEL) than the Z-score for the year 2018. Results show that the independent non-executive director, the foreign director and the institutional director, have a negative and significant impact on the financial soundness of Islamic banks. While, the Board of Director's size does not have any significant effect on the financial soundness of Islamic banks. This research contributes to fill the gaps in the literature that discussed the Board of Directors' role in the corporate governance of Islamic banking. In other words, it shows the role played by the Board of Director and improves our knowledge of the financial soundness-corporate governance relationship. With this paper, we hope to clarify the relationship between the Board of Director and the financial soundness of Islamic banks and provide new insights to the literature review. This study offers practical and valuable implications for banking associations, researchers and regulators. In other words, in addition to its theoretical and scientific value, this paper is practical and useful for professionals.

Keywords: Board of Director, Corporate Governance, Financial soundness, Islamic Bank

1.0 INTRODUCTION

In the last few decades, Islamic banks has rapidly grown in both size and number in the world due to the increasing demand from customers who are motivated to engage with banks that comply with shariah laws (Lassoued, 2018; Nomran *et al.*, 2018). Ullusever (2018) says that the financial assets of the Islamic financial sector grew 50% faster than the other banking sector and achieved US\$1.7 trillion in 2013. The financial assets of Islamic institutions are expected to reach US\$6.5 trillion in 2020.

The corporate governance structure is mainly guided by the Shariah Board and the Board of Directors (Nomran *et al.*, 2018; Khalil and Taktak, 2020). Grassa and Matoussi (2014) add that the Board of Director and the Shariah Board are the two most important organs that have a crucial role in the corporate governance of Islamic banking. The Board of Director is an internal organ linked to the management and the direction of the bank and it is composed of various directors (Amine, 2018). This board has the same role as a conventional bank's board. However, the principles of Islamic laws add responsibilities on the Islamic bank's board (Hakimi *et al.*, 2018). Directors must assure compliance with shariah principles (Accounting and Auditing Organization for Islamic Financial Institutions (AAOIFI), 2010; Ullah *et al.*, 2014; Hakimi *et al.*, 2018). Thus, the Board of Director is responsible for the effective role of the shariah corporate governance and verifies that this framework is compatible with the size of the Islamic financial institution (IFI) (Islamic Financial Services Board (IFSB), 2006; AAOIFI, 2010; Bank Negara Malaysia (BNM), 2010; Ullah *et al.*, 2014).

The effectiveness of the Board of Director depends on its composition (Klai and Omri, 2013; Hakimi *et al.*, 2018). In other words, the structure of the Board of Directors can affect the corporate governance of the bank and has a significant impact on its futures. Thus, it is important to study the Board of Director's characteristics. We note that, unlike conventional banks, the number of studies is limited. The Islamic banks are still characterized by a lack of publications about the corporate governance mechanism and its impact on the financial soundness.

In this study, we aim at diagnosing the effect of the Board of Director on the financial soundness of Islamic banks during the period 2005-2014. This paper goes as follows. Section 2 discusses a literature review on the relationship

between the Board of Director's characteristics and the financial soundness. We present in the third section the sample and the variables used. The discussion of the empirical results is in the fourth section. Section 5 summarizes the main conclusion.

2.0 LITERATURE REVIEW

2.1 Independent non-executive director

Proponents of agency theory suggest that having a high number of independent non-executive directors in the board allows a better activities control and reduces the manager opportunism (Jensen and Meckling, 1976; Fama and Jensen 1983). Moreover, the independent non-executive director support the Shariah Board in order to check the compliance of financial products with shariah principles (Quttainah *et al.*, 2013). While, the presence of independent non-executive directors guarantees the independence of the Board of Directors (Amine, 2018; Ramly *et al.*, 2018). According to the resource dependency theory, a large number of independent directors provides better knowledge and financial skills (Pfeffer, 1972 in Aduda *et al.*, 2013). The independent non-executive director is responsible for identifying the main risks and improving the performance and the stability of the IFI (BNM, 2015; Hakimi *et al.*, 2018; Buallay, 2019). However, other researchers ignore the positive effect of the independent non-executive directors on the financial soundness. Indeed, Independent non-executive director has difficulty to understand his role on the bank due to his limited participation in the financial institution's activities and the refusal of internal directors to disclose information (Lassoued, 2018). The Code of Best Practices for IFI corporate governance proposes that 2/9 of the directors should be independent non-executives (Code of Best Practices for CGIFI in Ibrahim *et al.*, 2012). In addition, Hawkamah (2011) suggests that a majority of the board members must be non-executive and at least 1/3 of them must be independent. The BNM Guide (2013) says that the number of independent directors must be less than 1/3 of the Director. We suggest the following hypothesis:

H1. The presence of an independent non-executive director has a positive and significant effect on the financial soundness of Islamic banks.

2.2 Foreign director

Proponents of agency theory argue that the presence of foreign directors can effect the management of the bank and decrease agency costs (Ujunwa, 2012; Klai and Omri, 2013). Moreover, the recruitment of directors of various nationalities improves the performance of banks by attracting new investors and contributes to high quality decisions (Daly and Frikha, 2015; Ramly *et al.*, 2018). The corporate governance standards of BNM Guide (2013) suggest foreign directors to ensure that the Board of Director has various skills and experience to perform its functions. Boussaada (2012), in contrast, states that the foreigners have difficult to manage the risk effectively. Masulis *et al.* (2012) and Rafindaa *et al.* (2018) add that foreign directors are less familiar with management practices and accounting rules. This hinders the ability of directors to control and have the necessary information (Masulis *et al.*, 2012). We hypothesize that:

H2. The percentage of foreign directors has a positive and significant effect on the financial soundness of Islamic banks.

2.3 Institutional director

According to passivity thesis, institutional investors penalize long-term investment projects and more particularly research and development investments. Brickley *et al.* (1988) add that institutional directors are dependent and vote for the interest of managers. Porter (1992) says that institutional shareholders have difficulties to analyze the financial institution and don't have any specific information about the firm. However, proponents of activism thesis predict that institutional directors encourage management to invest in long-term projects to increase productivity and improve the firm's performance (Jensen and Meckling, 1976; Hakimi *et al.*, 2018). Institutional directors have the expertise and a better knowledge of the of the sector issues compared to other directors (Hakimi *et al.*, 2018). Institutional investors are also more independent to control managers (Jensen, 1993). This reduces financial costs and risks and improves financial performance (Jensen 1993; Hakimi *et al.*, 2018). We suggest to test our third hypothesis:

H3. The percentage of institutional directors has a negative and significant impact on the financial soundness of Islamic banks.

2.4. Size

According to the agency theory, the larger Board of Director increases the problem communication and presents difficulties to coordinate efforts between directors. In addition, a high number of directors creates agency problems and encourages board members to pursue their own interests (Lipton and Lorsch, 1992; Jensen, 1993). Moreover, the higher number of directors increases the problem of information asymmetry which leads to conflicts of interest and increases agency costs (Prowses 1997). Bukair and Abdul Rahman (2015) and Buallay (2019) say that the size of the Board of Directors has a negative effect on the financial performance of banks. Proponents of resource dependency theory, in contrast, show that a large board has a variety of knowledge and experience (Goodstein *et al.*, 1994; Tazilah and Abdul Rahman, 2014; Amine, 2018). In addition, a board with a large number of directors increases supervisory capacity, makes effective decisions and meets the needs of stakeholders (Pfeffer, 1972; Fama and Jensen 1983). Many researchers show that a large board is associated with better financial performance and is able to better manage risk in order to avoid bankruptcy (Hakimi *et al.*, 2018; Ulussever, 2018; Buallay, 2019). The BNM (2013) Guide indicates that the number of directors is an important factor determining the board's efficiency and the appropriate size of the Board of Director is determined by the size and complexity of the IFI's activities. The sign of this variable is expected to be negative:

H4. The size of the Board of Director has a negative and significant effect on the financial soundness of Islamic banks.

3.0 METHODOLOGY

3.1 Sample and data

Our sample is composed of 67 Islamic banks observed over the period 2005-2014. Data is manually collected from international site of Islamic banks 'IBISONLINE'¹⁴⁶ and the site of each Islamic bank to download the annual reports. The rate of gross domestic product and the rate of inflation are extracted from the site of World Bank¹⁴⁷.

3.2 Variables measurement

3.2.1 Measurement of financial soundness (dependent variable).

We define the bank's financial soundness according to Khalil and Taktak (2020), we calculate the Z-score as follows:

Z-score = (ROA + K) / σ (ROA).

Where : ROA = Return on asset; k = Total equity/Total assets; σ (ROA) = Standard deviation of ROA.

3.2.2 Measurement of the independent variables

Seven characteristics of the board are tested. The presence of independent non-executive directors (**INE**) is a binary variable that is equal to 1 if an independent non-executive director exists and 0 otherwise¹⁴⁸, institutional directors (**AdmI**) measured by the percentage of institutional directors, foreign directors (**AdmE**) measured by the percentage of foreign directors and the Board of Directors' size (**TCA**) measured by the number of director. In order to improve our empirical results, we introduce 7 control variables. **TB** is the logarithm of the bank's total assets, **AB** is the logarithm of the bank's age, **Modèle** is a binary variable that is equal to 1 if the bank has a central Shariah Board and 0 otherwise, **Shariah** is a binary variable that is equal to 1 if the bank apply the shariah law and 0 otherwise, **NAAOIFI** is a binary variable which is equal to 1 if the bank applies the AAOIFI's standards and 0 otherwise, **PIB** is the gross domestic product, **TXI** is the inflation rate.

We suggest the below model to study the effect of Board of Director's characteristics on the financial soundness of Islamic bank:

$$Z\text{-score}_{it} = C + \beta_1 \text{INE}_{it} + \beta_2 \text{AdmE}_{it} + \beta_3 \text{AdmI}_{it} + \beta_4 \text{TCA}_{it} + \beta_5 \text{TB}_{it} + \beta_6 \text{AB}_{it} + \beta_7 \text{Modèle}_{it} + \beta_8 \text{Shariah}_{it} + \beta_9 \text{NAAOIFI}_{it} + \beta_{10} \text{PIB}_{it} + \beta_{11} \text{TXI}_{it} + \varepsilon_{it}$$

¹⁴⁶ Available on: www.ibisonline.com

¹⁴⁷ Available on: www.worldbank.org

Where C: a constant, $\beta_1 \dots \beta_{11}$: the coefficients to be estimated, ϵ_{it} : the error term, i: the bank (the individual), t: the period.

The model of our study is estimated by using the Panel Corrected Standard Errors method (PCSE) proposed by Beck and Katz (1995). We use method eliminates autocorrelation and heteroscedasticity errors by having results that are more robust.

4.0 RESULTS AND DISCUSSION

4.1 Descriptive statistics

The descriptive statistics in Table 1 shows that the average of (AdmE) variable is 20.660%. The mean for (AdmI) variable is 7.530%, which ranges from 0% to 100%. The Board of Director consists approximately of 8 directors, with minimum of 3 and maximum of 9.

Variables	Mean	SD	Skweness	Kurtosis	Median	Min	Max
AdmE%	20.660	25.860	1.302	3.879	11.111	0	100
AdmI%	7.530	21.572	3.343	13.564	0	0	100
TCA	8.217	2.398	0.475	3.395	8	3	19

Table 2 shows that banks of our sample are composed of 41.044% of independent non-executive directors.

Variables	INE	
Frequency %	1	0
	41.044	58.955

The descriptive statistics in Table 3 shows that 53.731% of banks belong to countries whose legal framework employed shariah laws and 65.671% of Islamic banking are governed by a central Shariah Board. 35.820% of Islamic banks belong to countries which apply the AAOIFI standards.

Variables	Modèle		Shariah		NAAOIFI	
Frequency %	1	0	1	0	1	0
	65.671	34.328	53.731	46.268	35.820	64.179

For other control variables, the mean for bank size (TB) is 9.055, which ranges from 1.269 to 12.013. The average of (AB) variable is 1.080. The mean for (PIB) variable is estimated at 4.558 while its minimum and maximum values are -10.500 and 18.600 respectively. (TXI) variable is ranged from -4.900 to 39.300 with an average of 7.793. The average of (Z-score) variable is 12.217.

Variables	Mean	SD	Median	Min	Max
TB	9.055	1.940	9.464	1.269	12.013
AB	1.080	0.402	1.146	0	1.792
PIB	4.558	3.511	4.700	-10.500	18.600
TXI	7.793	8.280	4.862	-4.900	39.300
Z-score	12.217	10.272	9.876	-1.359	70.954

4.2 Cross-Correlation Matrix and Test Variance Inflation Factor

The analysis of the Cross-Correlation matrix indicates the absence of the problem of multi-collinearity. All the coefficients of correlations are less than 0.7 - which corresponds to the limit set by Kennedy (2008). All our independent variables have a variance inflation factor (VIF) value that is less than the limit (10) suggested by Kennedy (1998).

4.3 Results and Discussion

4.3.1 Independent non-executive director and financial soundness

Table 6 shows that the coefficient on *INE* is negative and significant (p-value < 0.1). H1, thus, is not supported. We conclude that the independent non-executive directors has a negative and significant effect on the financial

soundness of Islamic banking. This result contradicts the findings of Lassoued (2018) and Buallay (2019) and confirms rooting theory implying that managers employ strategies making the role of directors passive. Managers design unqualified independent directors and to weaken the role of the Board of Directors. Plus, this result supports the agency theory, the resource dependency theory and the results of several researches (Quttainah *et al.*, 2013; Amine, 2018; Hakimi *et al.*, 2018; Mansoor *et al.*, 2019), and shows that the independent non-executive director is unable to manage the Islamic banks.

4.3.2 Foreign director and financial soundness

Table 6 indicates that the coefficient associated with (*AdmE*) variable has a significant and negative effect on the financial soundness of Islamic banks. H2, therefore, is not supported. This result contradicts agency theory and predictions of previous studies (Al-Musalli and Ismail, 2012; Daly and Frikha, 2015; Ramly *et al.*, 2018; Mansoor *et al.*, 2019). It appears that the benefits provided by the foreigners do not cover its costs (e.g. technologies, international expertise, skills, etc.)

4.3.3 Institutional director and financial soundness

The coefficient on *AdmI* does not have any significant impact on the financial soundness of Islamic banks (p -value > 0.1). H3, thus is not supported. This finding contradicts the prediction of activism thesis and passivity thesis, and does not confirm the study of Hakimi *et al.* (2018).

4.3.4 Size and financial soundness

Table 6 shows that (*TCA*) variable does not have any significant impact on the financial soundness of Islamic banks. H4, thus is not supported. This finding does not confirm, on one hand, proponents of agency theory and suggestions of resource dependency theory. On the other hand, it contradicts the results of many studies (Tazilâh and Abdul Rahman, 2014; Amine, 2018; Ulussever, 2018; Buallay, 2019).

4.3.5. Control variables and financial soundness

Table 6 indicates that the coefficient associated with (*TB*) variable is negative and significant, suggesting that the large bank adopts a bad strategy that does not permit the development of financial products. (*AB*) variable is negative and significant implying that the old bank cannot reach new technology. Furthermore, the significantly negative association between (*Modèle*) variable and financial soundness concludes that the central Shariah Board does not respond to the bank's need and is very rigid in its fatwas and does not support the study of Grassa (2013). (*Shariah*) variable has a significant and positive effect on the financial soundness of Islamic banks. This finding indicates that Shariah laws is used in a flexible way by the legal framework of the country and is updated to the financial environment. Plus, (*NAAOIFI*) variable has a negative and significant impact on the financial soundness of banks. This results reveals that the Islamic bank does not correctly use the AAOIFI's standards (Oud and Amedjar, 2016). Table 6 indicate that (*TXI*) variable and (*PIB*) variable do not have any significant effect on the financial soundness of Islamic banking.

Table 6. Results

Independent Variables	Coef.	Z	P> z
TB	-0.630	-3.14	0.002***
AB	-7.019	-3.98	0.000***
Modèle	-4.178	-2.10	0.036**
Shariah	8.155	2.67	0.007***
NAAOIFI	-8.399	-2.82	0.005***
PIB	0.011	0.19	0.853
TXI	0.052	1.14	0.254
TCA	-0.174	-1.13	0.259
INE	-1.724	-1.80	0.072*
AdmE	-0.046	-2.18	0.029**
AdmI	-0.009	-0.88	0.380
Cons	29.712	10.31	0.000***
R ²	39.61%		
N	670		

Notes : *significant at 10 per cent; ** significant at 5 per cent and *** significant at 1 per cent

4.4. Robustness Test

According to the International Monetary Fund (IMF) guide, financial soundness can be measured by two ways. The first approach employs the Z-score as an indicator of the financial soundness. The second proposes a set of indicators known as 'CAMEL' (IMF, 2006). To check the robustness of our finding, we employ other dependent

variables (CAMEL) than the Z-score for the year 2018. We use only two measures due to the unavailability of required data. The first indicator is the Capital Adequacy Ratio (CAR). It is measured by two ratios: $CAR1 = \text{Equity} / \text{Total Assets}$; $CAR2 = \text{Equity} / \text{Total Liabilities}$. The second indicator is the Equity ratio (E). It is calculated by two ratios: $ROA = \text{Return on asset} = \text{Net income} / \text{Total asset}$; $ROE = \text{Return on equity} = \text{Net income} / \text{Shareholder's equity}$. Table 7 shows that the result is not robust and depends on the dependent variable.

5.0 CONCLUSION

This research paper aims to empirically analyze the effect of the Board of Director's characteristics on the financial soundness of Islamic banking. To answer this question, we employ a sample composed of 67 Islamic banks over the period 2005-2014. We used the PCSE method to avoid heteroscedasticity and autocorrelation problems.

The findings show that the presence of independent non-executive director and the foreign director and have a negative and significant effect on the financial soundness of Islamic banking. However, the institutional director and the Board of Directors' size do not have any significant impact on the financial soundness of banks. To verify the robustness of our results, we use other dependent variables (CAMEL) than the Z-score. We conclude that the findings are not robust and belongs to the dependent variable.

Results emphasize the role of the Board of Directors and permit us to increase our knowledge regarding the corporate governance-financial soundness relationship. This paper offers a practical and useful evidence for academics, regulators, banking associations, etc. and makes a good contribution to the literature on the study of the corporate governance and their impact on the financial soundness of Islamic banking.

However, this research has limitations. The study is delimited to 2018 because of the missing of all required data. Plus, it is recommended to use in the future research other corporate governance mechanisms to better assess the relationship between the corporate governance structures and the financial soundness of Islamic banking.

Table 5. Cross-Correlation Matrix and VIF coefficients

	<i>INE</i>	<i>AdmE</i>	<i>AdmI</i>	<i>TCA</i>	<i>TB</i>	<i>AB</i>	<i>Modèle</i>	<i>Shariah</i>	<i>NAAOIFI</i>	<i>PIB</i>	<i>TXI</i>	<i>VIF</i>
<i>INE</i>	1.000											1.36
<i>AdmE</i>	0.109	1.000										1.14
<i>AdmI</i>	-0.046	0.073	1.000									1.09
<i>TCA</i>	0.021	0.057	0.061	1.000								1.26
<i>TB</i>	-0.117	-0.112	-0.016	0.084	1.000							1.13
<i>AB</i>	-0.225	-0.192	0.002	0.230	0.059	1.000						1.38
<i>Modèle</i>	0.136	0.111	0.124	-0.137	0.003	-0.078	1.000					1.70
<i>Shariah</i>	-0.138	0.082	0.011	0.053	0.076	0.027	0.463	1.000				2.38
<i>NAAOIFI</i>	-0.110	0.079	-0.066	0.091	-0.058	-0.027	0.474	0.693	1.000			2.58
<i>PIB</i>	0.025	0.023	-0.016	0.043	0.104	-0.096	-0.012	-0.052	0.015	1.000		1.27
<i>TXI</i>	-0.365	-0.067	0.055	0.045	0.124	0.264	0.141	0.320	0.136	-0.310	1.000	1.56

Table 7. Robustness test

Independent Variables	Capital Adequacy Ratio (C)						Equity (E)					
	CAR1			CAR2			ROA			ROE		
	Coef.	z	P> z	Coef.	z	P> z	Coef.	z	P> z	Coef.	z	P> z
TB	-1.358	-0.63	0.531	11.017	1.37	0.172	-0.530	-1.35	0.176	-2.846	-1.53	0.127
AB	-27.629	-1.73	0.084*	-92.199	-1.45	0.147	0.738	0.19	0.847	28.410	1.24	0.214
Modèle	-4.655	-0.63	0.527	-8.840	-0.28	0.782	-0.197	-0.08	0.938	16.606	1.31	0.189
Shariah	-6.588	-0.90	0.370	-7.200	-0.29	0.775	-5.176	-2.65	0.008***	-11.032	-1.25	0.212
NAAOIFI	35.154	4.00	0.000***	189.257	2.64	0.008***	0.235	0.16	0.871	-13.594	-2.37	0.018**
PIB	0.154	0.30	0.764	2.305	0.99	0.323	0.018	0.11	0.914	0.477	1.06	0.287
TXI	-0.669	-2.39	0.017**	-3.047	-2.26	0.024**	0.037	0.63	0.526	-0.416	-1.20	0.230
TCA	-1.657	-1.47	0.143	-9.555	-1.38	0.140	-0.005	-0.02	0.983	2.876	1.71	0.088*
INE	-0.929	-0.11	0.916	62.612	1.70	0.068*	-2.561	-0.97	0.334	-21.195	-1.58	0.115
AdmE	-0.023	-0.22	0.829	-0.598	-0.79	0.089*	-0.038	-1.39	0.164	-0.096	-1.41	0.158
AdmI	0.301	2.45	0.014**	0.664	1.48	0.432	-0.035	-1.37	0.171	-0.279	-1.47	0.142
Cons	87.883	3.09	0.002***	169.387	1.83	0.169	10.670	1.53	0.125	-15.103	-0.57	0.568
R²	28.25%			31.19%			19.21%			26.87%		
N	67			67			67			67		

Notes : *significant at 10 per cent; ** significant at 5 per cent and *** significant at 1 per cent

REFERENCES

- AAOIFI (2010), "Shariah Standards for Islamic Financial Institutions", Manama, Bahrain, Accounting and Auditing Organization for Islamic Financial Institutions.
- Abdul Alim, E. (2014), "Global Leaders in Islamic Finance", Industry Milestones and Reflections, Edition Wiley.
- Abdul Latif, R., Kamardin, H., Taufil Mohd, K.N. & Adam, N.C. (2013), "Multiple Directorships, Board Characteristics and Firm Performance in Malaysia", *Management*, Vol.3 No.2, pp.105-111.
- Aduda, J., Chogii, R. & Magutu, P.O. (2013), "An empirical test of competing corporate governance theories on the performance of firms listed at the Nairobi securities exchange", *European Scientific Journal*, Vol.9 No.13, pp.1857-7881.
- Ahn, S., Jiraporn, P. & Kim, Y.S. (2010), "Multiple directorships and acquirer returns", *Journal of Banking and Finance*, Vol.34, pp.2011-2026.
- Al-Janadi, Y., Abdul Rahman, R. & Haj Omar, N. (2013), "Corporate Governance Mechanisms and Voluntary Disclosure in Saudi Arabia", *Research Journal of Finance and Accounting*, Vol.4 No.4, pp.25-35.
- Al-Musalli, M.A.K. & Ismail, K.N.I. (2012), "Corporate Governance, Bank Specific Characteristics, Banking Industry Characteristics, And Intellectual Capital (IC) Performance Of Banks In Arab Gulf Cooperation Council (GCC) Countries", *Asian Academy of Management Journal of Accounting and Finance*, Vol.8 No.1, pp.115-135.
- Almutairi, A.R. & Quttainah, M.A. (2017), "Corporate governance: evidence from Islamic banks", *Social Responsibility Journal*, Vol.13 No.3, pp.601-624.
- Amine, B. (2018), "Contribution of Governance to Ensure the Stability of Islamic Banks: A Panel Data Analysis", *International Journal of Accounting and Financial Reporting*, Vol.8 No.3, pp.140-155.
- Anderson, C. A. & Anthony, R.N. (1986), "The new corporate directors", New York: John Wiley and Sons.
- Beck, N. & Katz, J.N. (1995), "What to do (and not to do) with time-series cross-section data", *American Political Science Review*, Vol.89 No.3, pp.634-647.
- BNM (2010), "Shariah Governance Framework for Islamic Financial Institutions", Islamic Banking and Takaful Department, RH/GL/012-23, Bank Negara Malaysia-Central Bank of Malaysia.
- BNM (2013), "Guidelines on Corporate Governance for Licensed Islamic Banks (GPI-i)", Islamic Banking and Takaful Department, RH/GL/002-1, Bank Negara Malaysia-Central Bank of Malaysia.
- BNM (2015), "Guidelines on Financial Reporting for Licensed Islamic Banks", Islamic Banking and Takaful Department, RH/GL/002-2, Bank Negara Malaysia-Central Bank of Malaysia.
- Boussaada, R. (2012), "L'impact De La Gouvernance Bancaire Et De La Relation Bancaire Sur Le Risque De Crédit : Cas Des Banques Tunisiennes", Doctoral Thesis in Management, University of Montesquieu-University of Tunis.
- Brickley, J., Lease, R. & Smith, C. (1988), "Ownership structure and voting on antitakeover Amendments", *Journal of Financial Economics*, Vol.20, pp.267-291.
- Buallay, A. (2019), "Corporate governance, Shariah governance and performance: A crosscountry comparison in MENA region", *International Journal of Islamic and Middle Eastern Finance and Management*, Vol. 12 No.2, pp.216-235.
- Bukair, A.A. & Abdul Rahman, A. (2015), "Bank performance and board of directors attributes by Islamic banks", *International Journal of Islamic and Middle Eastern Finance and Management*, Vol.8 No.3, pp.291-309.
- Chaffai, M. (2015), "Technical Efficiency and Stability to Shocks: A Comparison Between Islamic Banks and Conventional Banks In Mena Region", ERF Working Paper No.969, pp.1-25.
- Daly, S. & Frikha, M. (2015), "Corporate governance: what about Islamic banks?", *International Journal of Financial Services Management*, Vol.8 No.1, pp.18-41.
- Dhouibi, R. & Mamoghli, C. (2013), "Determinants of voluntary disclosure in Tunisian Bank's reports", *Research Journal of Finance and Accounting*, Vol.4 No.5, pp.80-94.
- Elyasiani, E. & Jia, J. (2010), "Distribution of institutional ownership and corporate firm performance", *Journal of Banking and Finance*, Vol.34, pp.606-620.
- Emerton (2012), "What Makes an Exceptional Independent Non Executive Director?", Edition The Korn/Ferry institute.
- Fama, E.F. (1980), "Agency problems and the theory of the firm", *The Journal of political economy*, Vol.88 No.2, pp.288-307.
- Fama, E.F. & Jensen, M.C. (1983), "Separation of ownership and control", *Journal of law and economics*, Vol.26, pp.301-325.
- Field, L., Lowry, M. & Mkrtychyan, A. (2013), "Are busy boards detrimental?", *Journal of Financial Economics*, Vol.109, pp.63-82.
- Gales, L.M. & Kesner, I.F. (1994), "An Analysis of Board of Director Size and Composition in Bankrupt Organizations", *Journal of Business Research*, Vol.30, pp.271-282.
- Grassa, R. (2013), "Shariah supervisory system in Islamic financial institutions: New issues and challenges: a

- comparative analysis between Southeast Asia models and GCC models”, *Humanomics*, Vol.29 No.4, pp.333-348.
- Grassa, R. & Matoussi, H. (2014), “Corporate Governance Of Islamic Banks: A Comparative Study Between GCC And Southeast Asia Countries”, *International Journal of Islamic and Middle Eastern Finance and Management*, Vol.7 No.3, pp.346-362.
- Hakimi, A., Rachdi, H., Ben Selma Mokni, R. & Hssini, H. (2018), “Do board characteristics affect bank performance? Evidence from the Bahrain Islamic banks”, *Journal of Islamic Accounting and Business Research*, Vol.9 No.2, pp.251-272.
- Haniffa, R.M. & Cooke, T.E. (2002), “Culture, Corporate Governance and Disclosure in Malaysian Corporations”, *ABACUS*, Vol.38 No.3, pp.317-349.
- Hassan, M.K., Sanchez, B. & Safa, M.F. (2013), “Impact of financial liberalization and foreign bank entry on Islamic banking performance”, *International Journal of Islamic and Middle Eastern Finance and Management*, Vol.6 No.1, pp.7-42.
- Hawkamah (2011), “Policy Brief On Corporate Governance For Islamic Banks And Financial Institutions In The Middle East And North Africa Region”, Hawkamah, The Institute for Corporate Governance.
- Ibrahim, S.H.B.M., Wirman, A., Alrazi, B., Nor, M.N.B.M. & Pramono, S. (2012), “Alternative Disclosure and Performance Measures For Islamic Banks”, Working Paper, International Islamic University Malaysia.
- IFSB (2006), “Guiding Principles On Corporate Governance For Institutions Offering Only Islamic Financial Services (Excluding Islamic Insurance (*Takaful*) Institutions And Islamic Mutual Funds)”, Islamic Financial Services Board.
- IMF (2006), “Financial Soundness Indicators”, International Monetary Fund.
- Iturriaga, F.J.L. & Rodríguez, I.M. (2014), “Boards of directors and firm performance: the effect of multiple Directorships”, *Spanish Journal of Finance and Accounting*, Vol.43 No.2, pp.177-192.
- Jensen, M.C. (1993), “The modern industrial revolution, exit and the failure of internal control systems”, *Journal of Finance*, Vol.48, pp.831-880.
- Jensen, M.C. & Meckling, W.H. (1976), “Theory of the firm: managerial behavior, agency cost and ownership structure”, *Journal of Finance Economics*, Vol.3, pp.305-360.
- Kasim, N., Htay, S.N.N. & Salman, S.A. (2013), “Conceptual Framework for Shariah Corporate Governance with Special Focus on Islamic Capital Market in Malaysia”, *International Journal of Trade, Economics and Finance*, Vol.4 No.5, pp.336-339.
- Kemp, M.N., Viviers, S. & Collins, S. (2018), “Exploring the causes and consequences of director overboardedness in an emerging market”, *International Journal of Disclosure and Governance*, Vol.15 No.2, pp.210-220.
- Kennedy, P. (1998), “A guide to econometrics”, Blackwell, Oxford.
- Kennedy, P. (2008), “A Guide to Econometrics”, Blackwell, Malden, MA.
- Khalil, A. & Taktak, N.B., (2020), “The impact of the Shariah Board’s characteristics on the financial soundness of Islamic banks”, *Journal of Islamic Accounting and Business Research*, DOI: <https://doi.org/10.1108/JIABR-08-2018-0127>.
- Klai, N. & Omri, A. (2013), “Corporate Board Characteristics and the Informativeness of Accounting Earnings: Evidence from Tunisia”, *International Journal of Financial Economics*, Vol.1 No.4, pp.133-142.
- Labaronne, D. (1998), “Les lenteurs de la privatisation en Europe de l’Est : une conséquence de la stratégie d’enracinement des managers”, *Revue d’Economie Politique*, Vol.108 No.5, pp.671-689.
- Lassoued, M. (2018), “Corporate governance and financial stability in Islamic banking”, *Managerial Finance*, Vol.44 No.5, pp.524-539.
- Lipton, M. & Lorsh, J.W. (1992), “A modest proposal for improved corporate governance”, *Business Lawyer*, Vol.48, pp.59-77.
- Mansoor, M., Ellahi, N. & Malik, Q.A. (2019), “Corporate governance and credit rating: Evidence of shariah governance from pakistan islamic banks”, *International Transaction Journal of Engineering, Management and Applied Sciences and Technologies*, Vol.10 No.18, pp.1-19.
- Masulis, R.W., Wang, C. & Xie, F. (2012), “Globalizing the boardroom-The effects of foreign directors on corporate governance and firm performance”, *Journal of Accounting and Economics*, Vol.53, pp.527-554.
- Nathan, S. & Ribière, V. (2007), “From Knowledge To Wisdom: The Case Of Corporate Governance In Islamic Banking”, *The journal of information and knowledge management systems*, Vol.37 No.4, pp.471-483.
- Nomran, N.M., Haron, R. & Hassan, R. (2018), “Shariah supervisory board characteristics effects on Islamic banks’ performance: evidence from Malaysia”, *International Journal of Bank Marketing*, Vol.36 No.2, pp.290-304.
- Oud, R.E. & Amedjar, A. (2016), “Analyse comparative des normes comptables appliquées à la finance participative – Cas de la Mourabaha”, *International Journal of Innovation and Applied Studies*, Vol.15 No.4, pp.812-821.
- Pfeffer, J. (1972), “Size and Composition of Corporate Board of Directors: The Organization and its

- Environment”, *Administrative Science Quarterly*, Vol.17 No.2, pp.218-228.
- Porter, M.E. (1992), “Capital disadvantage: America’s Failing Capital Investment System”, *Harvard Business Review*, Vol.76, pp.65-82.
- Prowses, S. (1997), “The Corporate Governance System In Banking: What Do We Know?”, *BNL Quarterly Review*, Special issue, pp.11-40.
- Quttainah, M.A., Song, L. & Wu, Q. (2013), “Do Islamic Banks Employ Less Earnings Management?”, *Journal of International Financial Management and Accounting*, Vol.24 No.3, pp.203-233.
- Rafindaa, A., Rafindab, A., Witiastutia, R.S., Surosob, A. & Trinugroho, I. (2018), “Board diversity, risk and sustainability of Bank Performance: Evidence from India”, *Journal of Security And Sustainability Issues*, Vol.7 No.4, pp.793-806.
- Ramly, Z., Datuk, N. & Nordin, M.H. (2018), “Shariah Supervision Board, Board Independence, Risk Committee and Risk-taking of Islamic Banks in Malaysia”, *International Journal of Economics and Financial Issues*, Vol.8 No.4, pp.290-300.
- Richardson, J. (1987), “Directorship interlocks and corporate profitability”, *Administrative Science Quarterly*, Vol.32, pp.367-386.
- Shachaf, P. (2008), “Cultural diversity and information and communication technology impacts on global virtual teams: An exploratory study”, *Information and Management*, Vol.45 No.2, pp.131-142.
- Tazilah, M.D.A.K. & Abdul Rahman, R. (2014), “Risk Management and Corporate Governance Characteristics in the Malaysian Islamic Financial Institutions”, *Research Journal of Finance and Accounting*, Vol.5 No.12, pp.116-128.
- Ujunwa, A. (2012), “Board characteristics and the financial performance of Nigerian quoted firms”, *Corporate Governance*, Vol.12 No.5, pp.656-674.
- Ullah, S., Khokhar, Z.A., Tanveer, N., Khan, M.W., Shabbir, G. & Ahmed, A. (2014), “Shariah Governance Framework For Islamic Banking Institutions”, Islamic Banking Department, State Bank Of Pakistan.
- Ulussever, T. (2018), “A comparative analysis of corporate governance and bank performance: Islamic banks with conventional banks”, *Research Journal of Business and Management*, Vol.5 No.1, pp.34-50.

THE IMPACT OF FINANCIAL MEASURES, EARNINGS MANAGEMENT AND SUKUK STRUCTURE ON SUKUK RATING: EVIDENCE FROM PAKISTAN.

Misbah Sadiq

Al Qasimia University, UAE

Abstract

This study has revealed the influence of financial measures (financial leverage, profitability and issue size), earnings management (return on assets, firm size and firm age) and Sukuk structure (musharakah, murabahah, mudarabah and ijarah) on Sukuk rating in Pakistan. Data has been gathered from annual reports of Sukuk issuing firms which are listed in Pakistan Credit Rating Agency. The firms has selected after nominating them from the security and exchange commission database which has been subject to numerous selection standards. It is hypothesized that financial measures, earnings management and Sukuk structure, have significant influences on Sukuk rating. The sample of this study is the 5 publicly listed Pakistani firms in the stock exchanges of Pakistan for the period of 2011 to 2019. The findings of current study suggest that financial measures indicator that is financial leverage has a positive influence on Sukuk rating, whereas profitability and issue size have a negative influence on Sukuk rating due to the reason that investors intention and perceptions play major role in buying Sukuk from markets and ultimately which impact the ratings. The results document that the indicators of earnings management that are return on assets, firm size and firm age have a negative influence on the Sukuk rating. Sukuk structure is also found to have a negative influence on Sukuk rating. The results of this research are the great contribution to the vast knowledge of Sukuk rating in literature associated to Islamic finance.

Key Words: Financial Measures; financial leverage, profitability, issue size, earnings management; return on assets, firm size and firm age, Sukuk structure; musharakah, murabahah, mudarabah ijarah, Sukuk rating.

1.0 INTRODUCTION

Practical indications have been found to be documented illustrating that issuance of Sukuk play key role in ratings of Islamic bonds which are known as Sukuk ratings. In this modern era, Sukuk have become an essential part of financial framework and effectively fulfills the needs of banking sector (Aloui, et al. 2015). Apart from banking sectors, other type of industries are also keeping hands on issuing Sukuk in markets for fulfilling their credit requirements. In the early years of 21st century, Europe has introduced Sukuk following seminal shariah-compliant and accelerated the issuance of Sukuk in response to increase in real estate investment (McMillen 2007). Mechanics of Sukuk market development have been focused in prior studies; particularly in Southeast Asia after occurrence of the financial crisis (Sharma 2001). According to an Islamic economics project analysis under the title "Sukuk Market in Pakistan Set for Take-Off", apart from Muslim countries, non-Muslim majority countries are also taking interest in it. UK treasury is issuing a Sukuk worth of £200 million. Inadequate researches in this area in Islamic finance provide the inspiration to conduct this research, analyzing the impact of financial measures, earnings management and Sukuk structure on Sukuk rating by considering the Pakistani firms offering Sukuk securities. (Paltrinieri, et al. 2019; Hasan, et al. 2019).

The purpose of this research is to deliver empirical and practical findings that whether or not financial measures, earnings management and Sukuk structure have significant impact on Sukuk rating of Sukuk issuing firms in Pakistan with the considering year in which Sukuk have been issued, an industry which is offering these Sukuk and corporate governance quality as control variables. This study will investigate the relationship between aforementioned independent variables (i.e. financial measures, earnings management and Sukuk structure) and dependent variable (Sukuk rating). This study provides the guidance to the firms issuing Sukuk in Pakistan. The findings of this study will redound to the Islamic financial system. Moreover, this study will be helpful to the firms offering Sukuk that how the financial measures, earnings management and Sukuk structure will influence their Sukuk rating. It will also serve as a future reference for researchers on the subject of Islamic financing and companies in different industries can be benefitted by Sukuk issuance.

2.0 LITERATURE REVIEW

2.1 Sukuk Rating Characteristics in Sukuk Markets:

With regard to the conservative perspective, Sukuk are the bonds, which can be described as a contract which is long term in nature, offering a bondholder to be made interest and principal payment by the borrower, on pre-specified dates. Sukuk are the debt certificates or documents which are issued not only by governments but also by the organizations through which particular amount of money is borrowed from the bondholders with the promise of paying back the money with interest (Sukor, et al. 1970; Naifar, and Hammoudeh, 2016). However, Sukuk are the Islamic notes which follow the Shariah compliance and includes the Shariah compliant activities. Interest in the case of Sukuk refers to the profit and loss that has been shared with the bondholders from investment in some underlying activity. Bond ratings or the credit ratings of a firm are known as Sukuk ratings, conventionally and referred to the future cash flow probability distribution of firms and ultimately to the bondholders, which are provided by the rating agencies. There are two types of Sukuk ratings found in the literature that are for debt issues called as bond ratings or credit issue ratings and financial obligations for Sukuk issuance in Sukuk markets and for debt issuers in Sukuk markets which refers to the credit worthiness (Huang, et al. 2004; Hossain, et al. 2020).

Creditworthiness of a firm refers to the fulfillment of costs related to debt services and principal payment in the future (Ashbaugh-Skaife, et al. 2006; Hossain, et al. 2018). The study reveals that firm's debt policy is influenced by the credit ratings (Graham and Harvey 2001). Moreover, financial leverage has an important determinant i.e. bond market access (Faulkender and Petersen, 2006). "Counterparty Sukuk ratings," "default Sukuk ratings" or "issuer Sukuk ratings" has been identified in literature (Huang et al. 2004), in which default Sukuk ratings have been identified for a short period of time where as Sukuk ratings or issue Sukuk ratings are considered for an extended period of time. Furthermore, rating agencies provide the definition for ratings, which do not involve in providing any indication for buying, selling or holding these debt instruments (Altman and Rijken, 2004; Nasreen, et al. 2020).

2.2 The relationship between Financial Measures and Sukuk Rating:

The extent to which the utilization of borrowed money is done by investors is referred as financial leverage and is also called debt ratio, which is found by dividing the total debt by the total assets (Huang et al. 2004; Vassalou and Xing, 2004; Agustriyana, et al. 2020). A study has indicated that financial leverage and bond ratings are inversely related to each other. Also, antitakeover propositions if found to be strong are related to lower cost of debt financing and if antitakeover propositions are weak, then it is related to the higher cost of debt financing (Klock, et al. 2005; Elhaj, et al. 2018). Mixed relationships have been found between financial measures, which are also referred as financial ratios, and Sukuk yields and Sukuk ratings in prior studies. Financial leverage has also been found to have significant negative correlation with ratings (Ashbaugh-Skaife, et al. 2006). No significant relationship has also been found between the financial leverage and bond ratings (Purwaningsih, 2013). A study has also illustrated that financial leverage has no effect on the relationship between financial ratios and Sukuk yields and Sukuk ratings (Kilapong and Setiawati, 2015; Al-raeai, et al. 2018).

Many researchers have used profitability with credit ratings and with its examples (Surkan and Singleton 1990, Joh 2003). Profitability has been investigated on the basis of raw and risk adjusted portfolio returns, portfolio returns on the basis of adjusted characteristics, stock returns individually and risk adjusted individual stock returns on the basis of asset pricing models which ultimately illustrated that higher raw, risk adjusted and characteristics adjusted returns have been realized by higher rated stocks relative to lower rated stocks (Avramov, et al. 2009). Negative relationship between credit risks and returns have been shown by previous researchers (Dichev, 1998; Garlappi, et al. 2008; and Campbell, et al. 2008). Moreover, the relationship between credit risk and returns are found positive that is between distress risk and returns, which is calculated in a study on distance to default (Vassalou and Xing, 2004). Also, profitability has been found to have no effect on the relationship between financial ratios and Sukuk yields and Sukuk ratings. Numerous studies have shown the firm size significance on working capital performance. Firm size has been found to have a positive relationship between financial ratios and Sukuk yields and Sukuk ratings (Kilapong and Setiawati, 2015).

Furthermore, it has been found that issue size has no significant effect on ratings of bonds (Purwaningsih, 2013). On the basis of extensive literature debate on the topic it can be assumed:

Hypothesis 1: Financial leverage, profitability and issues size affect the Sukuk rating.

2.3 The relationship between earnings management and Sukuk rating:

Worth of financial reporting has the influence of earnings management via related transactions of third party as preceding studies suggest (Jian and Wong, 2010; Lo and Wong, 2011; Shan, 2014). Earnings management are done for two incentives which drive the shareholders to involve in earnings management which are inflating

earnings to avoid the losses reported and for maintaining listing status and funds raising (Jian and Wong, 2010). This in turn effect the securities demand and ultimately the listings of firms. It has been mentioned in a study that earnings management does not improve the financial reporting quality as the manipulations done by the management through transactions of related party can be observed (Lo and Wong, 2011). It has been argued that operationalization of accounting quality has been done by earnings management and value relevance Lang et al. (2006), Barth et al. (2008) and Paananen and Lin (2009). A study conducted previously has provided an insight into the earnings management model made on the accrual basis. The findings of this research have shown an earnings management, correlation with the financial performance that is in terms of significance of the financial performance (Dechow, Sloan and Sweeney, 1995). Earnings management tool has been used by firms in which expected and unexpected core earnings are estimated by shifting decreasing income to special items from operating expenses for the purpose of inflating the core earnings (McVay, 2006).

Security valuation and investors' perceptions have been affected by the line item placement in the income statement which is consistent with the behaviour of managers provided by evidences (Bartov & Mohanram, 2014). Moreover, once this shifting has been done, it is difficult to unscramble them and this learning makes the investors on shifting operating expenses reappearance from the original place next year, to penalize these securities by not investing in them (McVay, 2006). Previous studies have illustrated that quality of financial reporting is influenced by related party transactions via earning management (Jian and Wong, 2010; Lo and Wong, 2011; Shan, 2014). This ultimately impacts the ratings of the credit issued in the financial markets. Earnings management has been operationalized in terms of return on assets, firm size and firm age (Shan, 2015; Godlewski, et al. 2016). The hypothesis formulated on the basis of aforementioned literature is as follows:

Hypothesis 2: Return on assets, firm size and firm age affect the relationship between earnings management and Sukuk rating.

2.4 Relationship between Sukuk Structure and Sukuk Rating:

Financial certificates are known as Sukuk, which are regarded as equivalent to bond Islamically (Yean 2009). Sukuk are not the conventional shares or bonds, but are defined as the equal value shares which represent ownership of undivided shares in tangible assets, services, specific projects and in the activity related to special investment (Anass, 2015; Azmat, et al. 2017). Generally, partial ownership in a debt refers to Sukuk Murabahah, partial ownership in an asset is referred as Sukuk al-ijara, project partial ownership as Sukuk al-musharakah and ownership which is partial in investments made is termed as Sukuk al-istithmar. Sale of debt with exclusion of selling at its face value has not been accepted by scholars and has been considered that receivable of debt has been a noticeable proportion (Lahsasna and Lin 2012; Elhaj, et al. 2015; Ayturk, et al. 2017). Based on the listed literature it can be hypothesised that:

Hypothesis 3: Musharakah, Mudarabah, Murabahah and Ijarah Sukuk affect the relationship between Sukuk Structure and Sukuk Rating.

2.5 Control variables:

The control variables are a year, industry dummies, and corporate governance quality which includes state ownership concentration, foreign ownership concentration and the supervisory board. Year dummy reflects the particular year in which the Sukuk have been issued. According to the perspective based upon the theory, companies with good corporate governance are projected to have a better credit rating. Industry dummy (industry) reflects the company's industry code in accordance with the industry classification of the Security and Exchange Commission of Pakistan (Shan, 2013). From competitive advantage it has been found that companies with poor corporate governance, in which the level of corporate governance can be measured by corporate governance ratings or indices, have low credit ratings (Shan, 2015). By considering the corporate governance quality as control variable, the relationship between the other variables of this study can be better understood.

3.0 RESEARCH METHODOLOGY:

The study takes data from the annual reports of all Sukuk issuing firms listed on Pakistan Stock Exchange. Ratings data of companies has been collected from Pakistan Credit Rating Agency from 2011 to 2019 period. After mining them from the security and exchange commission database, data has been subject to several selection criteria. First, the balance sheets of the firms must have at least twelve consecutive monthly return observations. From the population, those companies that are rated by Pakistan Credit Rating Agency from 2011 to 2019 period have been selected as sample for the study. Ratings are available on annual basis. The companies which are not listed on

Pakistan Stock Exchange that are privately owned companies have been excluded from further analysis and this study have focused on looking publicly listed companies only. So, data from a total of five companies have been available for the analysis. The rating has been assigned as AAA, AA, A and so on, in which higher numerical value assigned in this study corresponds to the lower credit rating or higher credit risk and vice versa which is similar to a previous research (Hovakimian, et al. 2009). For this study, correlation and ordered logit model has been used (Torres-Reyna 2012). Institutional theory has been utilized for the analysis purpose as a prior study has also used (Abulgasem, Muhamed and Ramli, 2015).

3.1 Conjecture of Model on the Basis of Conceptual Framework:

It has been found in empirical studies conducted previously that market reactions are influenced by the ratings which bring changes to bond ratings. There have been observed more strong reactions of market to low graded bonds (Goh and Ederington, 1999) which are known as below investment grade bonds as have more risk of default and are considered poorly rated firms (Hull, et al. 2004 and Purda, 2007). So, in this study ordered logit regression model has been used.

3.2 Ordered Logit Regression model:

The regression model as specified above has been used in which there are categories of the dependent variable and by using ordered logit regression model (Torres-Reyna, 2012), the linear equations have been formed, with inclusion of control variables in brackets that do not undergo any operation, which are as follows:

$$\begin{aligned} \text{SUKUKRit} &= \text{Bo} + \text{B1FLit} + \text{B2PRit} + \text{B3ISSUit} + e_{it} && (\text{Yearit}, \text{Industryit}, \text{CGQit}) \\ \text{SUKUKRit} &= \text{Bo} + \text{B1ROAit} + \text{B2FSit} + \text{B3FAit} + e_{it} && (\text{Yearit}, \text{Industryit}, \text{CGQit}) \\ \text{SUKUKRit} &= \text{Bo} + \text{B1SS} + e_{it} && (\text{Yearit}, \text{Industryit}, \text{CGQit}) \end{aligned}$$

Where, firm is mentioned “i” and time period is given “t”. Moreover, e_{it} refers to error terms in a specific model. SUKUKR is the Sukuk rating influenced by FL (financial leverage), PR (profitability) and ISSU (issue size) referred as model 1. In model 2, ROA (return on assets), FS (firm size) and FA (firm age) have been taken. Model 3 is comprised of SS (Sukuk structure). Bo is the slope which refers to the constant term. B1 to B3 refers to the coefficients related to the variables of interest.

3.3 Empirical Results, Analysis and Discussion:

Table 1 summarizes and describes the data gathered for this research. The following table illustrates the descriptive statistics.

Table 1: Descriptive Statistics of Research Variables

Variable	Median	Mean	Std. Dev	Min.	Max.
Financial Variables					
Financial Leverage	0.89	1.13	0.80	0.08	3.29
Profitability	0.39	0.57	0.63	0.00	2.01
Issue Size	4.00	5.83	3.04	2.30	9.90
Earnings Management					
Return on Assets	0.88	0.30	0.05	0.00	1.99
Firm Size	48.00	56.98	27.52	20.0	105.0
Firm Age	42.00	36.00	16.89	12.00	60.00
Sukuk Structure					
Musharakah, Mudarabah, Murabahah, Ijarah Sukuk	2.00	2.40	1.11	1.00	4.00
Control Variables					
Year	2013	2013	-	2011	2015
Corporate Governance Quality	3.00	3.00	1.44	1.00	5.00
State Ownership Concentration	0.10	0.15	0.14	0.00	0.40
Foreign Ownership Concentration	0.22	0.19	0.11	0.00	0.35
Supervisory Board	23.00	23.44	5.21	15.00	30.00
Sukuk Rating	1.00	0.56	0.50	0.00	1.00

No. of observations = 25.

Table 1 represents the descriptive statistics for this research study in which for financial variables influence, the average (median) percentage of financial leverage is 89% (113%). The standard deviation is 80% and the lower and the upper quartile value is 8% and 329% respectively. The average (median) percentage of Sukuk rating

held by the profitability is 57% (39%), standard deviation is 63% and the lower and upper quartile is 0% and 201% respectively. The average (median) percentage of Sukuk rating held by issue size is 4% (583%), standard deviation is 304% and the lower and upper quartile is 230% and 990% respectively. For the influence of earnings management, return on assets mean (median), standard deviation and lower and upper quartile values are 30% (88%), 50%, 0% and 199% respectively. For firm size, mean (median), standard deviation and lower and upper quartile values are 5698%, 48%, 2752%, 20% and 105% respectively. For firm age, mean (median), standard deviation and lower and upper quartile values are 36% (42%), 1689%, 12% and 60% respectively. For Sukuk structure i.e., For musharakah, mudarabah, murabahah and ijarah Sukuk the values of the mean (median), standard deviation and lower and upper quartile are 240% (200%), 111%, 100% and 400% respectively. The descriptive statistics for control variables are quoted in the table above. Turning to the Sukuk rating, mean (median), standard deviation and lower and upper quartile values are 56% (100%), 50%, 0% and 100% respectively.

3.4 Correlation Analysis:

Table 2 presents the correlation among different variables of this research study. The Spearman rank order correlation has been determined. The significance level has been taken at 0.01 level. Different characteristics of the variables have been taken for each variable as mentioned in the table 2. Variables also have inter-correlations suggesting that the presence of certain standard errors of coefficients on variables in the ordered logit model.

Table 2: Correlation Analysis

V	FL	P	IS	ROA	FS	FA	SS	Yr.	IND	SOC	FOC	SB	SR
FL	1												
P	-0.17*	1											
IS	-0.30*	-0.07*	1										
ROA	-0.13*	0.36*	0.08*	1									
FS	-0.20*	0.09*	0.31*	0.27*	1								
FA	-0.39*	0.04*	0.47*	0.05*	0.05*	1							
SS	-0.07*	0.22*	0.50*	0.19*	-0.28*	-0.32*	1						
Yr.	-0.06*	0.40*	0.01*	0.18*	0.11*	0.08*	0.07*	1					
IND	0.47*	0.08*	0.81*	0.01*	-0.22*	-0.70*	0.25*	0.00*	1				
SOC	-0.17*	-0.07*	0.15*	0.01*	0.55*	0.87*	-0.35*	0.01*	-0.29*	1			
FOC	0.09*	-0.10*	0.17*	-0.33*	-0.50*	0.31*	-0.15*	0.04*	-0.10*	0.40*	1		
SB	0.13*	-0.03*	0.54*	0.11*	0.22*	-0.33*	-0.40*	0.04*	0.00*	-0.39*	-0.56*	1	
SR	0.30*	-0.09*	-0.02*	-0.09*	-0.18*	-0.11*	-0.26*	-0.05*	0.17*	0.02*	0.27*	0.18*	1

*, **, *** indicate significance at the 0.01, 0.05, and 0.10 level or better, respectively. FL = Financial Leverage, P = Profit, IS = Issue Size, ROA = Return on Assets, FS = Firm Size, FA = Firm Age, SS = Sukuk Structure, Yr. = Year, IND = Industry, SOC = State Ownership Concentration, FOC = Foreign Ownership, SB = Supervisory Board, Sukuk Rating.

Research variable of financial leverage only has seen to have positive effects i.e. 0.30 which is significant at 0.01 level or below on relationship between financial measures and Sukuk rating. Whereas, profitability and issue size are found to have negative effects on the relationship between financial measures and Sukuk rating with -0.09 and -0.02 values. Return on assets, firm size, firm age and Sukuk structure are also found to have a negative relationship between earnings management and Sukuk rating with values of -0.09, -0.18 and -0.11 and Sukuk structure and Sukuk rating with a value of -0.26. However, the control variables are also found to have a significant relationship with Sukuk rating as illustrated in the table above. All the aforementioned variables are seen at the 0.01 level of significance.

3.5 Ordered Logit Regression Model Results and Discussion

This section discusses the effects of financial measures, earnings management and Sukuk structure on Sukuk rating with inclusion of control variables. Interaction terms have been added in the standard model with the bivariate methodology. In this research, marginal effects have been seen. In the general model, empirical tests for Sukuk rating are derived from the determinant functions of financial measure, earnings management and Sukuk structure which is adapted from a prior study (Hollis Ashbaugh, 2004): Sukuk Rating = f (financial measure, earnings management, Sukuk structure). The following table illustrates the ordered logit regression model results with inclusion of control variables from which following empirical models are extracted of which theoretical models have been mentioned above:

$$\begin{aligned} \text{Sukuk Rating} &= 0.31 (\text{FL}) + 0.00 (\text{PR}) - 0.00 (\text{ISSU}) \\ \text{Sukuk Rating} &= -0.00 (\text{ROA}) - 0.07 (\text{FS}) + 0.23 (\text{FA}) \\ \text{Sukuk Rating} &= 0.07 (\text{SS}) \end{aligned}$$

McFadden R squared value is 0.36 which shows the good model fit and p value is 0.00 which shows influence of independent variables on dependent variables for all the above three empirical models. All the independent variables that are, financial measures, earnings management and Sukuk structure are found to have influence that is impact on the dependent variable on the basis of coefficients which are significant at 0.01 level or better as illustrated in the following table that is Sukuk rating with incorporating the control variables. Moreover, positive relation has been found between financial leverage, profitability, firm age and Sukuk structure on Sukuk rating. However, negative relation has been found between issue size, return on assets and firms size.

Table 3: Ordered Logit Regression Model

Predicted	Estimated Coefficient			
Variables	Sign	Model-1	Model-2	Model-3
Financial Measures				
Financial Leverage	+	0.31*** (0.36)		
Profitability	+	0.00*** (0.53)		
Issue Size	-	0.00*** (-0.82)		
Earning Management				
Return on Assets	-		0.00*** (-0.00)	
Firm Size	-		0.07*** (-0.37)	
Firm Age	+		0.23*** (0.16)	
Sukuk Structure	+			0.07*** (0.08)
Control Variables				
Year		Included	Included	Included
Industry		Included	Included	Included
Corporate Governance Quality		Included	Included	Included
Stat Ownership Concentration		Included	Included	Included
Foreign Ownership Concentration		Included	Included	Included
Supervisory Board		Included	Included	Included
McFadden R-Squared		0.36		

*, **, *** indicate significance at the 0.01, 0.05, and 0.10 level or better, respectively.

4.0 CONCLUSION

The basic objective of this research study was to dig out that whether financial measures, earnings management and Sukuk structure have significant influences on Sukuk ratings or not. Also, control variables that are year, industry and corporate governance quality are taken into consideration in this research study. The findings of this study suggest that financial measure indicator that is financial leverage has a positive influence on Sukuk rating, whereas profitability and issue size have a negative influence on Sukuk rating due to the reason that investors intention and perceptions play major role in buying Sukuk from markets and ultimately which impact the ratings. The results document that the indicators of earnings management that are return on assets, firm size and firm age have negative influence on the Sukuk rating. Sukuk structure is found to have a negative influence on Sukuk rating. The results of this research has contributed to the vast knowledge of Sukuk rating in literature associated to Islamic finance. The current study has definite limitations of simply studying certain variables with Sukuk rating. This research study can further undertake with the incorporation of investor behaviors and other external and internal factors for more accurate results. On the basis of ordered logit, the three models which are mentioned above fit with the data and the results are found significant. However, longitudinal studies can be done by undertaking the data for ten years, which can be robust as well.

REFERENCES

- Agustriyana, D., Tarmidi, D., and Butar, D. J. 2020. CEO Power, Corporate Governance, Auditors' Reputation, and its Effects on Corporate Islamic Bonds Rating. *International Journal of Psychosocial Rehabilitation*, 24(2).
- Aloui, Chaker, Shawkat Hammoudeh, and Hela ben Hamida. 2015. "Global factors driving structural changes in the co-movement between sharia stocks and Sukuk in the Gulf Cooperation Council countries." *The North American Journal of Economics and Finance*. 311-329.
- Al-raeai, A. M., Zainol, Z., and Abdul Rahim, A. K. 2018. The Role of Political Risk and Financial Development Factors on Sukuk Market Development of Gulf Cooperation Council (GCC) Countries. *Asian Journal of Finance & Accounting*, 10(1), 242.
- Altman, Edward I and Herbert A Rijken. 2004. "How rating agencies achieve rating stability." *Journal of Banking & Finance* 28:2679-2714.
- Anass, PATEL. 2015. "Channeling Asset-Managed Sukuk towards SMEs financing: a case study for Sukuk Mudaraba (asset finance) applied to a French SME." *European Journal of Islamic Finance*.
- Ashbaugh-Skaife, Hollis, Daniel W Collins, and Ryan LaFond. 2006. "The effects of corporate governance on firms' credit ratings." *Journal of accounting and economics* 42:203-243.
- Avramov, Doron, Tarun Chordia, Gergana Jostova, and Alexander Philipov. 2009. "Credit ratings and the crosssection of stock returns." *Journal of Financial Markets* 12:469-499.
- Ayturk, Y., Asutay, M., and Aksak, E. 2017. What explains corporate sukuk primary market spreads?. *Research in International Business and Finance*, 40, 141-149.
- Ayturk, Y., Asutay, M., and Aksak, E. 2017. What explains corporate sukuk primary market spreads?. *Research in International Business and Finance*, 40, 141-149.
- Azmat, S., Skully, M., and Brown, K. 2017. The (little) difference that makes all the difference between Islamic and conventional bonds. *Pacific-Basin Finance Journal*, 42, 46-59.
- Dechow, P. M., & Schrand, C. 2004. Earnings quality. USA: The Research Foundation of CFA Institute.
- Dechow, P. M., Ge, W., & Schrand, C. 2010. Understanding earnings quality: A review of the proxies, their determinants and their consequences. *Journal of Accounting and Economics*, 50(2-3), 344-401.
- Dechow, P., Sloan, R., G., and Sweeney, A., P. 1995. Detecting Earnings Management. *The Accounting Review*, Vol. 70, No. 2 (Apr., 1995), pp. 193-225
- Elhaj, M. A. A., Muhamed, N. A., and Ramli, N. M. 2015. The influence of corporate governance, financial ratios, and Sukuk structure on Sukuk rating. *Procedia Economics and Finance*, 31, 62-74.
- Elhaj, M. A., Muhamed, N. A., and Ramli, N. M. 2018. The effects of board attributes on Sukuk rating. *International Journal of Islamic and Middle Eastern Finance and Management*.
- Elhaj, M., A., A., Muhamed, N., A., and Ramli, N., M. 2015. The Influence of Corporate Governance, Financial Ratios, and Sukuk Structure on Sukuk Rating. *Procedia Economics and Finance*. 31. 62 - 74
- Godlewski, C. J., Turk-Ariss, R., and Weill, L. 2016. Do the type of sukuk and choice of shari'a scholar matter?. *Journal of Economic Behavior & Organization*, 132, 63-76.
- Gunny, K. A. 2010. The relation between earnings management using real activities manipulation and future performance: Evidence from meeting earnings benchmarks. *Contemporary Accounting Research*, 27(3), 855-888.
- Hasan, R., Ahmad, A. U. F., and Parveen, T. 2019. Sukuk risks—a structured review of theoretical research. *Journal of Islamic Accounting and Business Research*.
- Hasan, R., Ahmad, A. U. F., and Parveen, T. 2019. Sukuk risks—a structured review of theoretical research. *Journal of Islamic Accounting and Business Research*.
- Hossain, M. S., Uddin, M. H., and Kabir, S. H. 2018. Sukuk as a financial asset: A review. *Academy of Accounting and Financial Studies Journal*.
- Hossain, M. S., Uddin, M. H., and Kabir, S. H. 2020. Sukuk and Bond Puzzle: An Analysis with Characteristics Matched Portfolios. *Emerging Markets Finance and Trade*, 1-26.
- Huang, Zan, Hsinchun Chen, Chia-Jung Hsu, Wun-Hwa Chen, and Soushan Wu. 2004. "Credit rating analysis with support vector machines and neural networks: a market comparative study." *Decision support systems* 37:543-558.
- Jordan, J., L., Carlson, C., N., and Wilson, J., R. 1996. Financial indicators measure fiscal health. *Journal (American Water Works Association)*, Vol. 89, No. 8, Optimizing Treatment Processes, pp. 34-40
- Kilapong, Greacee Janly Victoria and Lulu Setiawati 2015. "The Effect of Accounting And Nonaccounting Information To The Rating Of Company's Bond."
- Lahsasna, Ahcene and Lee Sze Lin. 2012. "Issues in islamic capital markets: Islamic bond/Sukuk." Pp. 495-512 in 3rd International Conference on Business and Economic Research (3rd ICBER 2012) Proceeding.
- McMillen, Michael JT. 2007. "Asset securitization Sukuk and Islamic capital markets: Structural issues in these formative years." *Wis. Int'l LJ* 25:703.
- McVay, S. 2006. Earnings management using classification shifting: An examination of core earnings and special items. *The Accounting Review*, 81(3), 501-531.
- Naiifar, N., & Hammoudeh, S. 2016. Dependence structure between sukuk (Islamic bonds) and stock market conditions: An empirical analysis with Archimedean copulas. *Journal of International Financial Markets, Institutions and Money*, 44, 148-165.
- Nasreen, S., Naqvi, S. A. A., Tiwari, A. K., Hammoudeh, S., and Shah, S. A. R. 2020. A Wavelet-Based Analysis of the Co-Movement between Sukuk Bonds and Shariah Stock Indices in the GCC Region: Implications for Risk Diversification. *Journal of Risk and Financial Management*, 13(4), 63.
- Paltrinieri, A., Hassan, M. K., Bahoo, S., and Khan, A. 2019. A bibliometric review of sukuk literature. *International Review of Economics & Finance*.
- Purwaningsih, Septi. 2013. "Faktor Yang Mempengaruhi Rating Sukuk Yang Ditinjau Dari Faktor Akuntansi Dan Non-Akuntansi." *Accounting Analysis Journal* 2.
- Roychowdhury, S. 2006. Earnings management through real activities manipulation. *Journal of Accounting and Economics*, 42(3), 335-370.
- Shaikh, S., A. & Saeed, S. SUKUK BOND: The Global Islamic Financial Instrument. MPRA Paper No. 26700, posted 16. November 2010.
- Shan, Y.G., 2013. Can internal governance mechanisms prevent asset appropriation? Examination of type I tunneling in China. *Corp. Gov. Int. Rev.* 21 (3), 225-241.
- Sharma, Krishnan. 2001. "The underlying constraints on corporate bond market development in southeast Asia." *World development* 29:1405-1419.

DOES THE TRIPLE BOTTOM LINE REPORTING MATTERS TO NIGERIAN STAKEHOLDERS? A LITERATURE SURVEY APPROACH

Aminu Abdullahi^{*a} & Alhassan Kawu Abubakar^b

^{*a} Department of Accounting, Faculty of Management Science, Usmanu Danfodiyo University, Nigeria

^b Department of Accountancy, School of Financial Studies, Federal Polytechnic, Bida, Niger State Nigeria

Abstract

The investigation about the relationship between Triple Bottom Line reporting and firm financial performance have been undertaken across industries in Nigeria private sector with mixed findings without any study that synthesizes the available findings with a view to present a common ground of the scholars. This study, therefore, synthesised the available findings as a basis of drawing a conclusion for Nigerian firms and the stakeholders as to whether or not the TBL reporting affects Nigerian stakeholders than the traditional reporting that provide for the needs of the shareholders only. This study is based on a literature survey design as data were collected from syntheses of empirical studies conducted across Nigeria. The study concludes that TBL reporting in Nigeria matters to the sustainability of firms and the stakeholders in general. As a result, the paper recommends that the TBL reporting framework be enshrined in law and in accounting standards, making it compulsory for firms to adopt across Nigeria rather than a voluntary forms as it is now.

Keywords: TBL, Sustainability, social, environmental, financial reporting, performance

1.0 INTRODUCTION

One of the cardinal objectives driving the affairs of firms in the private sector is a financial performance which is measured in many ways including the uses of internal mechanism such as financial statement and market-based mechanisms such as uses of market share price which is having a direct link with the financial health condition of a firm released to the public. A firm is said to have sustenance if the objective of financial performance, ie profitability is perpetually achieved (Brigham & Ehrhardt, 2008; Chandra, 2008). Many factors directly linked to financial performance among which is continuous reporting of events as they occurred in a summarized form to the stakeholders. This report is important as it tells the stakeholders about the achievements of the firm and how their objectives are maximized over the reporting period. It discloses earning capacities, capital structure's strength, liabilities, and as well as asset base. Before the discovery of the Triple Bottom Line (TBL) reporting model by Elkington in 1994 the traditional reporting framework was in use, which served the interest of only the shareholders by disclosing the profits and its related indices at the detriment of other stakeholders.

Asuqua, Dada and Onyeogaziri (2018), Emeka-Nwokeji and Osisoma (2019), Adonai, Emeh, Dennis and Thompson (2019), Ekwueme, Egbunike, and Onyali (2013), Onyali (2014) are among studies conducted in Nigeria context that have established a direct relationship between the report that serves the interest of the stakeholders rather than just shareholders with financial performance. In other words, these studies concluded that a report that serves the interest of all stakeholders increases the long-run profitability of the reporting firm. These Scholars have conducted empirical studies that revealed links between financial performance and disclosure of financial information of firm's dealings in events benefiting the people and the planet in Nigeria focusing on selected sectors of the economy with findings relative and restricted to the study areas via the uses of deductive reasoning, thus many related studies have not established the position of TBL viz a vis the performance of Nigeria firms as a whole.

This study, therefore synthesises the findings of existing studies as a basis for concluding for Nigerian firms and the stakeholders. This is done via the uses of inductive reasoning where the individual finding is examined into as a basis of conclusion. To be specific, the objectives of the study are to reviews empirical findings and a). Conclude as to whether the TBL reporting positively or negatively affects Nigerian stakeholders than the traditional reporting that provide for the needs of the shareholders only or not. b). To establish the measurement favoured by Nigerian researchers.

Therefore, the methodology adopted for this study is the literature survey design. This is chosen because available empirical studies on TBL and sustainability reporting were reviewed as a basis of concluding. Following this introductory section are a review of concepts and empirical studies and concluding sections.

2.0 CONCEPTUAL AND EMPIRICAL LITERATURES

2.1 Concepts, components and measurement of Triple Bottom Line (TBL)

Triple Bottom Line reporting refers to a method of measuring the economic, environmental, and community service impacts of an organization rather than the traditional practice of measuring the bottom line concerning financial performance. In 1994 John Elkington coined the concept of the triple bottom line (TBL) as a new term to advance his sustainability agenda and hence also refers to as sustainability reporting/accounting, thus yielding to the pressures mounted before the 1990s by environmentalists and social justice advocates. In the words of Richardson (2004), Triple Bottom Line Accounting by a firm concentrates on the financial and economic promotions and prosperities or destruction done to as a result of firm's numerous activities. He further identifies two components of the TBL Accounting framework. First is the restatement of traditional accounts to highlight financial flows that are sustainability-related and are valuable to the shareholders; second as to do with reporting financial information relative to economic, environmental, and social performance to the external stakeholders. TBL reporting, therefore, goes beyond reporting to shareholders through financial statements to encompass reporting of the impact of the firm economic, social and environmentally wise. It aimed at providing information on profit, people and planet.

As stated earlier on John Elkington in 1994 identified three concepts of TBL/Sustainability reporting. According to him, the concepts are Social, Environmental and Economic/Financial performances and these are the key factors that a firm ought to manage to bring about sustainable goals and attainment of objectives of all the stakeholders. To buttress on the three concepts and their measurements Elkington (1997); Amos, Uniamikogbo and Atu (2016); Slaper and Hall (2011) among others contend that Financial bottom line also known as economic bottom line upon which the traditional financial reporting bottom line of profitability values are based and is concern about the short and long runs economic well being of the stakeholders. That is the impact of the firm's activities on the economic system resulting in value creation for the stakeholders (Elkington, 1997). The economic line links the growth of a firm to the growth of the economy and how well it contributes to support it. In other words, it deals with the financial and economic value added to the stakeholders now that support the future generation.

The social aspect on the other hand, refers to engaging in promoting or enhancing the wellness as well as just business practices to the labour, human capital, and the community at large (Elkington, 1997). According to Goel (2010) social equity practices provide value to society and "give back" to the community. He further gives examples of these practices to include employment and providing health care coverage among others. Therefore, social performance concentrates on the association that exist between the organization and the community and covers issues connected to community participation, employees and fair wages. To add more, it has been suggested by Stoddard, Pollard and Evans (2012), Dwyer (2005); Sauvante (2001) that the social dimension of TBL also called social capital consists of two components of human capital and investment. Human capital includes employees, contractors, suppliers, and advisors while investment is made up of the social systems that support the business such as scholarships, philanthropies, etc.

The Environment/Ecological line of TBL according to Goel (2010) and Amos et al (2016) is referred to engaging in practices that do not jettison the environmental resources of future generations. It focuses on reducing greenhouse gas emissions, the efficient use of energy resources, and minimizing the ecological footprint, etc. Stoddard, Pollard and Evans (2012), Onyx and Bullen (2000) and Schnake (1991) likens environmental line to natural capital/resources because natural resources such as clean air, clean water, oil and gas, forests, minerals, fish, and soil are all embedded in the environment and as such report that provides how a firm deals with these items in protecting and otherwise is very important to the survival of the firm and the future generation and hence the need to the concept of TBL

According to Slaper and Hall (2011) measuring the three dimensions of Economic, Social and Environment have been a source for concern because the three bottom lines have no same basis of measurement. They went further to state three forms of measuring the concepts as follows; (a). Using the metric of the currency, according to them this basis provides a common unit of measurement, e.g. Naira, Dollar, Cedes, etc., however, finding a common monetary basis of measurement is a challenge, for instance, attaching monetary value on social and environmental/ecological benefits or damages cannot be measured accurately using monetary value. Issues such as the right value of lost wetlands or endangered species is still a challenge. (b). Using index is another form of

measurement, this takes care of the challenges of using the monetary value 'as long as accounting method are backed up with generally accepted accounting standards/principles, that allows for comparisons between entities for instance, inter and intra companies comparison against established benchmarks. There are, however, some elements of subjectivity using index, for example, how would the index measured? Would each of the three components of TBL get an equal measurement? Do they each get an equal measurement? Is the social category more important than the environment? Who decides?' (c). To overcome the inherent limitations of monetary value and index, another unit of measurement was put forward as 'stand-alone unit' for example, Acres of wetlands, rehabilitation, scholarship, good air, and water preventive and curative measures would all stand as a unit of measurement of their own. The limitation of this approach is an abundance of multiple parts of dissimilar metrics of measurements.

Another approach to measurement similar to those already discussed is the measurement in compliance with the Global Reporting Initiative (GRI). According to Stanzel (2010) GRI as a program was developed by Ceres a Boston-based non-profit organization for the United Nations Environmental Program (UNEP). The GRI provides measurement criteria for each of the concepts of TBL. The economic/financial line has measurement indicators such as (1) sales, revenue, profits and returns on investment or shareholder value (2) taxes paid and (3) monetary flow models. Industrial specific models can also be used in this regard. For example, in hotel industry heads in beds can be used, in the banking industry Interest generated can be used to measure the economic line of TBL. According to GRI the following indicators are mostly used to measure the social aspect of TBL: (1) Labour practices (2) community impacts (3) human rights, and (4) product responsibility. Goldsworthy (2000) added employee retention rates, job satisfaction levels and investment per employee in sickness and physical damage prevention as part of a model for measuring social line of TBL. The environment or ecological line is evaluated according to (1) air quality (2) water quality (3) energy used (4) waste produced (solid and toxic waste) (5) use of recycled materials and (6) water sources significantly affected by an organization's use of water

2.2 Concept and measurement of firm financial performance:

The concept of financial performance, according to Naz, Naqzi, and Ijaz (2016) and Kenton (2020) is a concept generally used to weigh how well a firm is able to use available resources to generate revenues and of course the shareholders' wealth and firm profitability. It is also to gauge a firm financial health condition over time as well as measuring the firm's results from policies implemented in absolute monetary value and relative terms (Kenton, 2020 & Business Dictionary, 2020).

Measurement of firm financial performance can be achieved in two ways; first through the internal mechanism of a financial statement where metrics such as sales revenue, operating income, cash flow from an operation, the total unit of sales. Furthermore, the growth rates, such as gross and net profit margin, returns of Assets, return on equity and finally, through Market-based mechanism in which the market price per share is used to determine the aggregate value of a firm (Kenton, 2020). Market-based valuations are usually based on the forces of demand and supply of a firm's shares as reflected by divergent information of the firm's performance or otherwise coming to the market from the firm. Another measure is the Topin's Q which is expressed as the market value of a company divided by its asset's replacement cost (Hayes, 2019). Financial performance can as well be expressed in forms of liquidity and profitability performances. Measures such as gross profit, return on equity, and investment has a direct link with profitability. However, Liquidity performance is measured through indices such as ratios for instance quick, current, leverage, solvency, cash, and working capital ratios are measures of liquidity also derived from financial performance (Anthony, 1970). And through the growth of the firm size, i.e. the firm's total asset (Uwuigbe et al, 2018 & Business Dictionary, 2020)

2.3 Reviews of empirical literature:

As a basis of conclusion, related studies were reviewed and presented in tabular form for ease of drawing conclusion, arranged in order of year and findings. The presentation started with studies that found TBL reporting positively affects the Nigerian firms' financial performance and the stakeholders and followed by those that opined otherwise.

3.0 CONCLUSION

Arising from the objectives of this study as stated in the introductory section, and from the reviews of accessible empirical studies in Nigeria on TBL/ Sustainable reporting where 13 out of 19 (68%) reported positive relationship this study concludes that TBL reporting enhances firms' performance and improves stakeholders' general objectives. Consequently, it is established that TBL reporting in Nigeria matters to the sustainability of firms and

the stakeholders in general. Furthermore, it concludes that Nigerian researchers mostly adopt the index/coding (mostly in the form of GRI) method of measuring components of TBL. It is, therefore, recommended that a TBL reporting framework be enshrined in law and accounting standard, making it compulsory for firms to adopt across Nigeria rather than voluntary forms it is now

Table 1: Studies with positive relationship between TBL and financial performance of Nigerian firms

NO	Author(s)/Date	Title/objective	Sector	Methodology	Findings
1	Luke and Olugbenga (2013)	The study investigated whether or not the TBL reporting contributes meaningfully to the sustenance of firms in the Nigerian banking sector.	Banking sector	Both the secondary and primary sources of data were used and the chi-square statistical technique was used in data analysis	The findings revealed that TBL reporting positively affects all the stakeholders positively rather than the current traditional reporting, which hinged more on financial reporting alone.
2	Ijeoma (2014)	The objective of this study was to determine whether triple bottom line reporting contributes to corporate sustainability and improves employee motivation with a view to reducing labour turnover in Nigeria	Panel of some listed firms in Nigeria	The primary source was used in data collection while the non-parametric statistical test of Kruskal Wallis was utilized for data analysis	From the result, it was found that TBL reporting contributes positively and significantly to corporate sustainability as well as improving the employees' motivation and thus reduces labour turnover rate in Nigeria.
3	Onyali (2014)	The study established the connection between triple bottom line accounting/reporting and sustainability of the professional firms' management in Nigeria.	Chartered Accountants in Awka, Anambra state	The Primary source of data was used. The descriptive and inferential statistics were utilized in data analysis, multiple regression model to be specific run using SPSS version 20.	The findings suggest that adoption of TBL accounting procedures in the Nigeria context would enable the effective management of social and environmental costs relative to the organization
4	Akenbor (2014)	The study investigated the relationship between triple-bottom-line (TBL) accounting and sustainable development (SD) in Nigeria	Banking sector	The CBN statistical bulletin was used as a source of secondary data collected over the affected years and the Bertelsmann's transformation index of the World Bank Group and linear regression technique was utilized in data analysis	The findings generated from this study revealed that TBL accounting has a positive significant impact on sustainable development in Nigeria
5	Kwaghfan (2015)	The study examined the impact of sustainability reporting on firm performance in Nigeria	Selected quoted nonfinancial companies in NSE	Secondary source was used and data extracted from the sample of 64 listed firms in Nigeria since 2002 through 2012	The study reported a positive and significant relationship between sustainability reporting and proxies of performance, i.e. ROA, ROE, EPS and margin of net profit
6	Ekwe, Odogu and Mebrin (2017)	Examine the importance of TBL accounting pattern on the profitability of oil and gas firms in Nigeria	Listed Oil and gas firms	Secondary source of data was used and the collected data were analysed using the OLS.	The findings indicated that the adoption of triple bottom line accounting pattern in Nigerian oil and gas sector enables accurate reporting of profitability to stakeholders
7	Okpa, Ojong and Ndifon (2017)	This research investigates the impact of triple bottom line (TBL) disclosure of the financial performance (bottom line performance) of non-financial firms listed on the Nigerian stock exchange between the period 2005 to 2016	Quoted non financial firms in Nigeria	TBL is measured by the level of disclosure of environmental, social and economic initiatives, while bottom line or financial performance is measured by Return on Assets, Return on Equity and Net Profit Margin. Multivariate regression models were specified for testing, formulated hypotheses	The study revealed that while TBL Disclosure impacted ROA and ROE, it does not have a significant impact on NPM of organizations listed on the floor of NSE
8	Uwuijbe et al (2018)	To shed light on the direct and indirect relationship between sustainability reporting and quoted Nigerian banks performance	Banking	Both primary and secondary sources of data were used in panel regression as a technique for data analysis	The findings show that sustainability reporting relates directly with quote Nigerian DMBs
9	Efiiong and Akpa (2018)	The paper looks into the effect of triple bottom line disclosures on performance for the selected companies	Selected listed gas and oil organisations in Nigeria	Secondary data were used and GRI standards were used, employing the ex post facto design. Twelve companies were studied for 10 (ten) years with descriptive statistics alongside panel data regression model employed both the fixed and random effects estimation was carried out to enable appropriate choice using Hausman specification test statistics and the necessary diagnostic test were also carried out	The results indicated that proxies of TBL disclosures significantly and positively affect financial performance.
10	Egbunike Et al (2018)	The study ascertains the level of sustainability accounting practice and its relationship with sustainability disclosure by Multinational Corporations in Nigeria	Cross section of Multinational Corporations in Nigeria	The study used primary source of data with the survey research design. The One-Sample Chi -Square Test and Pearson Correlation coefficient	The paper revealed a high level of social, environment and economical accounting practice among Multinational Corporations in Nigeria; And also, a positive relationship between social accounting practice and social disclosure by MC in Nigeria; environmental accounting practice

					and environmental disclosure by MC in Nigeria; and financial/economic accounting practice and economic disclosure by MC in Nigeria.
11	Adonai et al (2019)	Determining the effect of Social bottom line management on the patronage of Money Deposit Banks in South East, Nigeria and Financial bottom line management on organizational profitability	Money Deposit Banks in South Eastern Nigeria	The research design utilized for the study was descriptive survey design with 917 as the elements in the study population. Analysis of data was done using inferential statistical technique such as Regression and Pearson's Product Correlation models computed using statistical package for social sciences (SPSS) version 20	Social and Environmental bottom line management had a significant positive influence on turnover among money deposit Banks in South East, Nigeria while financial bottom line management has no significant positive effect on organizational profitability among money deposit banks in South East Nigeria
12	Emeka-Nwokeji and Osisioma (2019)	The study investigated how sustainability disclosures affect financial performance as represented by market value of firms in Nigeria as an emerging economy using company specific disclosures	93 out of 120 quoted non-financial firms in Nigeria as at December 2015	Ex Post Facto research design was adopted with a secondary source of data via content analysis of 2006 through to 2015 financial statements. Firm market value was measured by Tobin's q. The data were analyzed using descriptive, correlation and regression statistics.	The results showed that overall sustainability disclosures have statistically significant and positive effects on the firm's market value
13	Effiong, Oti and Akpan (2019)	The study evaluated the effect of triple bottom line disclosures on firms' value	Oil and gas industry, i.e. 12 Listed Oil and Gas companies	The study used a secondary source of data derived from Fact Book of Nigerian stock exchange and financial Reports. GRI standards were used with ex post facto research design. Descriptive and panel data regression model was used to employ.	The findings revealed that the disclosures of three components of TBL positively and significantly affect financial performance as measured by different indicators.

Table 2: Studies with negative or no relationship between TBL and financial performance of Nigerian firms

1	Onyali, Okafor and Onodi (2015)	The effectiveness of triple bottom line disclosure practice of corporate firms in Nigeria	Selected investors, customers and Accountants in Nigeria	The descriptive design was employed. The primary data were summarized using tables while the hypotheses were tested using one-sample z-test via the SPSS ver 22	Their findings showed that the TBL disclosure practice in Nigeria is not effective as far as the investors and consumers are concerned.
2	Ogbodo (2015)	The study determined whether or not the triple bottom line accounting satisfied stakeholders than conventional financial reporting	Nigerian stakeholders such as investors, customers and Accountants	The primary source of data was utilized and the data were processed with the aid of tables with one-sample z test utilized in data analysis via SPSS version 20.	The findings indicated that TBL reporting inversely affect Investors and as such lost confidence in the use of it for investment decision.
3	Udeh and Akporien (2015)	The research examined TBL accounting practices and relationship with the host locality in Nigeria	Niger Delta community	Fixed form of questionnaires was administered in a survey while data were analysed using correlation and one-way analysis of variance (ANOVA) at the 5 % level of significance. Statistical package for social sciences (SPSS) software (version 16.0) was also used	The study reveals that TBL accounting reports were differently perceived by the host communities with the management of the affected companies.
4	Asuqua, Dada and Onyeogaziri (2018)	To determine the relationship between sustainability reporting and corporate performance	Quoted brewery firms in Nigeria were selected	Secondary sources of data were used and were obtained from the audited financial reports of the three (3) brewery firms under study for a period of five (5) using the regression model to analyze data.	The result of the study shows that the TBL disclosure has no statistically significant effect on return on asset (ROA) of selected firms in Nigeria
5	Dibia and Nwaigwe (2018)	The relationship between corporate sustainability reporting and firm profitability	Quoted firms across Nigeria	The study adopted ex post facto research design. Data used for the study were sourced from annual reports of the companies for the period 2011 to 2015 and analysed using Multiple regression analysis technique	The findings revealed a negative relationship between return on equity and corporate sustainability reporting and No significant relationship was established between earnings per share and corporate sustainability reporting
6	Ifeanyi, Azubike and Iormbagah (2020)	This study examined effects of triple bottom line reporting on the financial performance of listed Nigerian oil and gas firms.	Listed Oil and gas firms sector	The study adopted Ex-post facto research design with Content analysis approach. The secondary data was used from 2012 through 2016 and analyzed using a multiple OLS regression technique.	The first finding revealed that social disclosure had no significant effect on return on assets of listed oil and gas firms in Nigeria while the second finding revealed that economic disclosure had no significant effect on return on assets of listed oil and gas firms in Nigeria. The final results also revealed that environmental disclosure has no significant effect on return on assets of listed oil and gas firms in Nigeria

REFERENCES

- Adonai O.O.P, Emeh N. C. Dennis I. C, & Thompson, S. T. (2019). Effect of sustainability reporting on performance of the selected money deposit banks in southeast Nigeria. *International Journal of Research in Management Fields*. Retrieved from [http://rspublication.com/IJRMF/IJRMF Vol 3 \(4\)](http://rspublication.com/IJRMF/IJRMF Vol 3 (4))
- Akenbor C. O. (2014). Triple bottom-line accounting and sustainable development in Nigeria international journal of advanced research in statistics, management and finance vol. 2 no. 1
- Amos O. A, Uniamikogbo E. & Atu G. (2016). Sustainability and Triple bottom Line: an overview of two interrelated concepts. *Igbinedion University Journal Of Accounting*. Vol. 2
- Anthony, R. N. (1970): *Management Accounting Text and Cases*. Illiosis, Richard D. Irwin, Inc. Pg. 4303.
- Asuqua A. Dada E. T. & Onyegaziri U. R. (2018). The Effect of Sustainability Reporting on Corporate Performance of Selected Quoted Brewery Firms in Nigeria. *International Journal of Business & Law Research*. 6(3):1-10. Retrieved from <https://www.researchgate.net/publication/333852779>
- Brigham E. F. & Ehrhardt M. C. (2008). *Financial Management: Theory and Practice*, Twelfth Edition, Thomson Higher Education, 5191 Natort Boulevard Mason, OH 45040, USA
- Chandra P. (2008). *Financial Management: Theory and Practice*, 7th edition, Tata McGraw-Hill Publishing company Ltd, & West Patel Nagar, New Delhi
- Dibia O. & Nwaigwe G. (2018). Sustainable Development Practices and Corporate Financial Performance: A Survey of Selected Quoted Companies in Nigeria. *Asian Journal of Economics, Business and Accounting*, 7(1), pp. 1-13. doi: 10.9734/AJEBA/2018/40995. Retrieved from <https://www.journalajebe.com/index.php/AJEBA>
- Dictionary B. (2020). *Business Dictionary.com*. Online Dictionary
- Dwyer L. (2005). Relevance of triple bottom line reporting to the achievement of sustainable tourism: a scoping study. *Tourism Review International*. Volume 9, Number 1, pp. 79-93(860). Retrieved from <https://doi.org/10.3727/154427205774791726>
- Effiong S. A & Akpa D. C. (2018). *Triple bottom line reporting and shareholders' value: the oil and gas perspective retrieved from ORCID: https://orcid.org/0000-0002-1310-9860*
- Effiong S. A, Oti, O. & Akpa D. C. (2019). The effect of triple bottom line disclosures on performance selected oil and gas companies in Nigeria Egbunike, F.C., Emudainohwo, O.B., Gunardi, A., Kumiasari, F. & Prihanto, J.J.N. (2018). Sustainability Accounting Practices and Disclosure by Multinational Corporations in Nigeria. *Journal of Applied Economic Sciences*, Volume XIII, Summer, 3(57): 751– 759.
- Ekwe, M. C. Odogu, L. I. & Mebrim A. A. (2017). Triple bottom line accounting pattern and profitability of firms. (An empirical study of oil and gas companies in Nigeria. *International Journal Of Research In Business, Management And Accounting*. Vol 3 (9)
- Elkington, J. (1994). Towards the Sustainable Corporation: Win-Win -Win Strategies for Sustainable Development. *California Management Review*, 36[2], 90-100
- Elkington, J. (1997). Triple Bottom Line Reporting: Sustainability's Accountant. Environmental management: Readings and cases. Retrieved from <https://books.google.com.ng/>
- Emeka-Nwokeji N. & Osisioma B. C. (2019). Sustainability Disclosures and Market Value of Firms in Emerging Economy: Evidence from Nigeria. *European Journal of Accounting, Auditing, and Finance Research* Vol.7, No.3, pp.1-19. Retrieved from https://papers.ssrn.com/sol3/papers.cfm?abstract_id=3463656
- Goel P. (2010). Triple Bottom Line Reporting: An Analytical Approach for Corporate Sustainability. *Journal of Finance, Accounting & Management*. Vol. 1 Issue 1, p27-42. 16p.
- Goldsworthy A. (2000). The triple bottom line: Shareholders society sustainability. *BHERT News* 4–6.
- Hayes A. (2019). *Corporate Finance & Accounting Financial Ratios*. Retrieved from <https://www.investopedia.com/terms/q/qratio.asp>
- Ifeanyi C. Azubike J. U. & Iormbagah J. A. (2020). Effect of triple bottom line reporting on the financial performance of listed oil and gas firms in Nigeria. *International Journal of Management Studies and Social Science Research*. Vol 2, issue 2
- Ijeoma N. B. (2014). Assessing the impact of triple bottom line reporting on problem of corporate sustainability in Nigeria. *American Journal of Service Science and Management*. Retrieved from <http://www.openscienceonline.com/journal/ajssm>
- Kenton W. (2020). *Fundamental Analysis Tools for Fundamental Analysis*. <https://www.investopedia.com/terms/f/financialperformance.asp>
- Kwaghfan A. (2015). Impact of sustainability reporting on corporate performance of selected quoted companies in Nigeria. Being a thesis presented to the department of accountancy, faculty of business administration, university of Nigeria, Enugu campus in partial fulfillment of the requirements for the award of Ph.D in Accountancy
- Luke O.O. & Olugbenga A. A. (2013). Triple Bottom Line Reporting: An Assessment of Sustainability in Banking Industry in Nigeria. *Asian Journal of Finance & Accounting* Vol. 5, No. 2
- Naz F. Naqvi F. & Ijaz F. (2016). Financial performance of firms evidence *Journal of Teaching and Education*, 05 (01), 81-94. Retrieved from <https://www.researchgate.net/publication/305993207>
- Ogbodo, O. C. (2015). A Stakeholder Approach to Triple Bottom Line Accounting: Nigerian Experience. *International Journal of Academic Research in Business and Social Sciences*. Vol. 5, No. 6. Retrieved from <http://dx.doi.org/10.6007/IJARBS/v5-i6/1663>
- Okpa I, Ojong E. N & Ndifon E. P (2017). Triple Bottom Line Disclosure and Bottom Line Performance of Quoted Companies in Nigeria. *Scholars Journal of Economics, Business and Management*. DOI: 10.21276/sjebm
- Onyali C. I. (2013). Triple Bottom Line Accounting and Sustainable Corporate Performance. *Research Journal of Finance and Accounting* Vol.5, No.8 retrieved from www.iiste.org
- Onyali C. I., Okafor T. G. & Onodi B. (2015). Effectiveness of Triple Bottom line disclosure practice in Nigeria-stakeholders perspective. *European Journal of Accounting, Auditing and Finance Research*. Vol.3, No.3, pp.70-85. Retrieved from www.eajournals.org
- Onyx J. & Bullen P. (2000). Measuring Social Capital in Five Communities. *The Journal of Applied Behavioural Science*. Retrieved from <https://doi.org/10.1177/0021886300361002>
- Richardson J. (2004). *Accounting for Sustainability in Adrian Henriques and Julie Richardson (eds) The Triple Bottom Line: does it all add up*. EarthScan: London, UK.
- Sauvante M. (2001). *The triple bottom line: a boardroom guide*. Retrieved from <https://www.researchgate.net/publication/285533760>
- Schnake, M. (1991). Organizational citizenship: A review, proposed model and research agenda. *Human Relations*, 44: 735–759. Retrieved from <https://www.tandfonline.com DOI: 10.1177/001872679104400706>
- Slaper T. F & Hall T. J (2011). *The Triple Bottom Line: What Is It and How Does It Work?* Retrieved from <http://www.ibrc.indiana.edu/ibr/2011/spring/article2.html>
- Stenzel P. L. (2010). Sustainability, the Triple Bottom Line, and the Global Reporting Initiative *Global edge Business review*. Vol. 4, No. 6 retrieved from <https://globaledge.msu.edu/content/gbr/gBR4-6.pdf>
- Stoddard J. E., Pollard C. E. & Evans M. R. (2012). The Triple Bottom Line: A Framework for Sustainable Tourism Development. Volume 13, - Issue 3. Retrieved from <https://www.tandfonline.com/doi/abs/10.1080/15256480.2012.698173>

BUSINESS RISK MANAGEMENT IN ISLAMIC INSTITUTIONS AND BANKS: A PERSPECTIVE

Adil Darwish Al Zaabi & Ali Ahmad Alkaabi

Faculty of Economics and Management Sciences, University Sains Islam Malaysia, Negeri Sembilan, Malaysia.

Abstract

The banking sector frequently confronts several challenges and risks concerning their operations. These risks can hamper everyday operations, cripple the business system, and cause financial loss. In this regard, this study strives to propose the objectives and measures of risk management in Islamic institutions and banks to consolidate the concepts of Islamic banking. The researchers highlighted the types of risks that Islamic banking tends to avoid and the efforts to deal with them. Furthermore, it also recommended measures to circumvent the challenges faced by Islamic financial institutions, i.e., lack of experts regarding risk management and the weak risk management system. Thus, the paper also suggested several recommendations, such as diversification of investment and financing tools to reduce risks, attract savings, and diversify resources.

Keywords: Risk Management, Islamic Institutions, Banks, Finance

1.0 INTRODUCTION

Comprehensive risk management refers to a systematic decision-making process in an environment of uncertainty about an event that can happen. Especially, whose probability and impact can have adverse consequences [1]. It is an unavoidable concern in the day-to-day development of business. It constitutes a strategic challenge to achieve better performance, growth, and competence as it a substantial component of essential business management [2]. Integral management implies a holistic global administration of risks at all levels of the organization to facilitate the achievement of strategic decision-making. Taking into account the interaction of the company with its environment, the relationship with stakeholders, the interrelation between processes, and the implementation of mechanisms that guarantee business continuity demand strategic risk management [3]. Thus, risk management requires structured, comprehensive, and permanent strategies to identify, evaluate, and monitor all risks that can hinder obtaining business goals. Regarding regulations, international Coso II [4] established an integrated framework, based on strategic objectives with different techniques, focusing on the potential risks to financial information. This is one of the previous norms of risk management [5]

We assume that Islamic banks are a national product derived from Islamic jurisprudence, and the data of Islamic civilization aimed to extend the development efforts and keeping pace with contemporary banking approaches. As noted by [6], Islamic Banking ensures interest-free loans known as "Qard-e-Hasna" as the proposed mode of financing in Islamic Banking is "Financing on Profit & Loss Sharing." Aimed at the ease of recipients, Qard-e-Hasna aims to facilitate both the individuals and society. However, Islamic banks work on the same structures and principles of conventional banking. They provide distinguished asset transformation details, brokerage service, risk management guidance, and others [7]. Due to interest-free loans and banking services, Islamic banking prohibits debt security, and due to this, creditors enjoying benefits without interests or any other additional charges [8]. Thus, many approved sources are offering better solutions to contemporary issues, foremost of which is banking. In this way, Islamic banking is developed as a genuinely national product in its originality and development. [9]

2.0 MANAGEMENT OF TRENDS AND RISKS THROUGH BUSINESS INSURANCE

The risks for Islamic banks increased due to several developments, growing use of new financial instruments, and integration of technology. However, to tackle the challenges, risk management was raised as an essential aspect of banking. For this purpose, the Basel Committee included risk management efficiency as one of the crucial axes for determining bank solvency. Therefore, Islamic banks sought to search for hedging methods that differ from the traditional model that does not serve the nature of their business [10]. According to (Rahahleh, 2019), Islamic financial services institutions must follow comprehensive procedures for managing risks and preparing reports about them. These procedures may involve appropriate oversight by the senior management to identify, measure, follow-up, and monitor the relevant risk categories and prepare reports on them. These procedures include steps to

comply with the Sharia and ensure the adequacy of the information submitted to the supervisory authorities.

Comprehensive risk management offers improvements in the strategic planning stage, threat minimization, opportunity exploitation, and management of transversal risks. Risk management also aims to obtain an integrated business vision, asset protection, and improvement of the image of the organization [3]. It also allows a more efficient allocation of resources and develops a structure that enables future activities to be carried out in a controlled manner and promotes business growth. [11]

However, for Comprehensive Risk Management to be effective, it must be aligned with the critical functions of the organization. For a program or system to be successful, it must be included within the operations of corporate governance, where the board of directors and the Senior management define the policies, strategic objectives, and guidelines of risk management, while conducting a continuous review of it [12]. Additionally, organizations should design appropriate performance indicators, and managers assume responsibilities before risk committees and the board of directors for compliance and feedback [13]. More than formal and simple regulatory compliance, organizations should possess robust and effective risk management systems [14]. Organizations must contemplate policies, procedures, and other mechanisms to intervene in threats or vulnerabilities to prevent or control existing risks. It is crucial to design an appropriate risk management system, and senior executives should provide permanent guidance, channeling, and supervisory bodies for the implementation, compliance, and effectiveness of the policies, procedures, and controls [15].

But all areas of the organization should ensure adequately managing the risk, benefitting all the interest groups to minimize the threats, which may positively contribute to achieving the institutional objectives [11]. Such management is a productive investment that can bring companies protection and beneficial results while avoiding risks in the medium and long term business activities. This management should not be assimilated as another legal obligation, but rather as a social responsibility, having the importance it truly deserves. [16]

As noted, risk management should incorporate stages, i.e., identification, evaluation, control, and monitoring [17], sufficient budgetary, human, technical, and training resources must be provided to the areas responsible for compliance and management. These resources will help in risk prevention, detection, mitigation, and control [15].

3.0 RISK MANAGEMENT IN ISLAMIC BANKS

Concerning risk management in Islamic banks, a compliance program is a pre-requisite as one of the essential steps. As it is necessary to define how vulnerable an institution is, to qualify at what level it is, and to determine the class, impact, frequency, and assessment of the controls needed to nullify the possible risks. This depends on the thorough analysis of the different risk generating factors, i.e., type of clients, size of the entity, market where it operates, location or jurisdictions, products and services, distribution channels, the applicable regulations of the country, the international standards, and best practices that can be assimilated [19].

The role of risk analysis is influential in improving assurance. Still, the risks are lethal while investing in financial derivatives due to the uncertainty attributed to their prices, dependence on future expectations, and the extent to which their access opportunities are realized [20]. Despite its high risks, investors use banking and financial institutions as a source of generating revenue. Capitalists generate revenue through investing in financial contracts where their income depends on fluctuations in the prices of the original financial instruments (the subject of the contract). Besides, risk management allows investor opportunities to identify market risks related to financial agreements and manage each risk separately.

Risk management allows the investor opportunities to identify market risks related to financial contracts and manage each risk separately to reduce the risk in general by hedging the effects of price fluctuations, which arise from either fluctuating interest rates, fluctuating exchange rates, or fluctuating prices of investment portfolios, whether they are commodities or securities. The risks of the last lender: Those who follow the budgets and investments of Islamic banks note the following:

Reserves:

The budgets of Islamic banks refer to a large number of reserves and their diversity, including mandatory reserves, optional reserves, and investment risk reserves, etc. In some banks, "Takaful and Solidarity Fund," and all the previously mentioned reserves aim to protect the creditors against a defined risk. Creditors resort to internal sources that can compensate for urgent withdrawals as there is no "final lender" to rely on during emergencies. Whereas traditional banks have many means that they may resort to during crises, as the central banks aid these banks in

several ways, including:

- Cash loans.
- Take advantage of the process of discounting and re-discounting.
- Resorting to cash reserves.
- Other means of liquidating their assets, which are for the most part prohibited by Islamic banks

Staff:

Although Islamic banks recently started their functioning, they still face a shortage of skilled, trained workforce capable of Islamic banking. It is no secret to anyone how humans are influential over the success or failure of any institution [11]. The human factor is one of the most potent factors in the progress of the institution, especially during the era of economic openness and the consequences of globalization. The seriousness of the human element lies not only in his mastery of work but also in belonging to the institution in which he works. An employee reflects his institution, especially in the Islamic banking financial institutions, whose objectives are socioeconomic development [21]. However, in some cases, Islamic Banking is more concerned with social well-being such as Nasser Social Bank in Egypt as the Islamic Banks grant loans for purely social well-being purposes [22]. Moreover, unfortunately, Islamic banks still depend on their cadres to attract traditional bank employees. In some cases, they offer leadership positions, forgetting that Islamic banking is entirely different from conventional banks. But still, Islamic Banking resembles conventional banking in an administrative manner which can be viewed from two distinguished angles [23]:

- a) **Selection of employees:** There are exceptional standards and specifications for the employee who wants to work in Islamic banking, guided by the Almighty saying: "She said, Father, I rent it, it is better than the one who hired the honest strong." Islamic Banking needs vital, honest employees, and these two words set a particular criterion to choose an employee. A person who is strong in his faith, strong in his conscience, firm in his argument, sincere, and trustworthy for the interests of others and the institution he works in.
- b) **Staff training:** "Because God loves one of you to do a job well enough," the employees must be adequately trained and qualified before they go to the field. They should be armed with knowledge and skills before dealing with the clients. For his purpose, their training includes:
 - i) **Technical training:** i.e., knowing the nature of the work with relevant knowledge, accompanied by field training. For this purpose, the employee should possess all the skills that can help him in his professional life.
 - ii) **Islamic Fiqh:** Employees should be well-trained regarding Islamic Sharia and law. Their understanding regarding Islamic banking should be well-capable of dealing publicly with banking matters and also how to deal with complex issues. They should also possess the capability to make reasonable arguments regarding their work by explaining the ideologies and principles of the work they are performing.

4.0 CONCLUSION

A fundamental component in the actual risk culture is to create commitment and generate collective awareness in all areas of the organization. Especially, to the point where all employees feel obligated to detect and prevent the crystallization of risk or control it and reduce it by minimizing its probability and, by taking it as a moral duty rather than the labor duty [15]. In general, Islamic banks should be cautious in their exposure to such risks and put in place systems for identifying, controlling, and managing them. Thus, the development of culture and techniques of risk management in banks is an integral part of the responsibility of the banking sector. In this regard, Islamic bank professionals must become fully aware of the nature of the risks and establish efficient risk management. As a result, risk awareness, power, and evaluation are distinct features for the success of banks and Islamic financial institutions concerning achieving their goals.

The growth trends in the Islamic financial industry depend on the way these institutions deal with risks. These banking organizations can avail more acceptance in international markets if they apply international control standards, which will also improve their competitiveness. However, the Islamic Banking industry is still suffering from lack of risk management due to weak measurement tools, inadequate internal controls over risks, and lacking sufficient risk management strategies. Perhaps the coming years may celebrate the development of these strategic tools because of the development of Islamic financial engineering on the one hand and the increasing global acceptance of them on the other hand.

5.0 RECOMMENDATION

The study recommends establishing a department for scientific research dedicated to Islamic Banking to propose new techniques to keep pace with the modern banking arena. Especially on scientific and practical methods in studying, evaluating, and selecting clients can be of greater magnitude. According to scientific and empirical foundations, appropriate selection, training, and preparation of employees can bring fruitful outcome for the Islamic

banking institutions. Altering the existing investment style (Murabahah) and shift to other investment formulas to reflect the Islamic investment and financing model should be taken consideration. Similarly, urging the local government to create favorable conditions for Islamic banking is also recommended.

REFERENCE

- N. Al Rahahleh, M. Ishaq Bhatti, and F. Najuna Misman, "Developments in risk management in Islamic finance: A review," *J. Risk Financ. Manag.*, vol. 12, no. 1, p. 37, 2019.
- M. Benlemlih, A. Shaikat, Y. Qiu, and G. Trojanowski, "Environmental and social disclosures and firm risk," *J. Bus. Ethics*, vol. 152, no. 3, pp. 613–626, 2018.
- Y. Choi, X. Ye, L. Zhao, and A. C. Luo, "Optimizing enterprise risk management: a literature review and critical analysis of the work of Wu and Olson," *Ann. Oper. Res.*, vol. 237, no. 1–2, pp. 281–300, 2016.
- K. M. A. Islam and O. A. Barghouthi, "Risk Management of Islamic Banking: An Islamic Perspective," *Int. J. Islam. Bank. Financ. Res.*, vol. 1, no. 1, pp. 25–28, 2017.
- A. Islam and S. Amir, "Liquidity problems in Islamic banks; Reasons, impacts and solutions," 2016.
- A. R. Khaki and M.-D. Sangmi, "Islamic Banking: Concept and Methodology," *SSRN Electron. J.*, no. March 2019, 2012, doi: 10.2139/ssrn.2184856.
- M. J. T. Mcmillen, "Islamic Banking: A brief Introduction," no. June, 2015.
- Z. Iqbal, "Introduction to Islamic Finance & Banking World Bank-BRSA-TKBB Joint Workshop on "Innovative Product Development in Islamic Banks"," 2017, [Online]. Available: http://www.tkbb.org.tr/Documents/Yonetmelikler/Session1_Zamir_Iqbal_Introduction-to-Islamic-Finance-Banking.pdf.
- M. Aldoseri and A. C. Worthington, "Risk Management in Islamic Banking: An Emerging Market Imperative," in *Risk Management in Emerging Markets*, Emerald Group Publishing Limited, 2016.
- J. Pope, *The compliance costs of taxation in Australia: an economic and policy perspective*. Division of Business and Administration, Western Australian Institute of ..., 1992.
- A. F. Abdul Ganiyy, A. F. Ogunbado, and N. H. Ahmad, "Islamic perspectives on liquidity risk management practices of Islamic banks in Malaysia and Bahrain," *Asian J. Multidiscip. Stud.*, vol. 5, no. 1, pp. 100–108, 2017.
- M. Alghizzawi *et al.*, "The Impact of Smartphone Adoption on Marketing Therapeutic Tourist Sites in Jordan," *Int. J. Eng. Technol.*, vol. 7, no. 4.34, pp. 91–96, 2018.
- N. Noomen and M. B. Abbes, "The Determinants of Credit Risk Management of Islamic Microfinance Institutions.," *IUP J. Financ. Risk Manag.*, vol. 15, no. 1, 2018.
- S. gaelle Mohamad, Kasim, "Council for Innovative Research," *J. Adv. Chem.*, vol. 10, no. 1, pp. 2146–2161, 2014.
- N. S. A. Megeid, "Liquidity risk management: conventional versus Islamic banking system in Egypt," *J. Islam. Account. Bus. Res.*, 2017.
- C. D. Huang, J. Goo, K. Nam, and C. W. Yoo, "Smart tourism technologies in travel planning: The role of exploration and exploitation," *Inf Manag.*, vol. 54, no. 6, pp. 757–770, 2017.
- J. B. Barney, "Strategic factor markets: Expectations, luck, and business strategy," *Manage. Sci.*, vol. 32, no. 10, pp. 1231–1241, 1986.
- V. Parsad, C., Prashar, S., & Sahay, "Impact of Impulsive Personality Traits and Store Environment on Impulse Buying Behavior.," *J. Bus. Manag.*, p. 23., 2017.
- W. T. Cheng and C. Chen, "The impact of e-learning on workplace on-the-job training," *Int. J. e-Education, e-Business, e-Management e-Learning*, vol. 5, no. 4, p. 212, 2015.
- V. Manual and A. Z. Xin, "Impact of Tax Knowledge, Tax Compliance Cost, Tax Deterrent Tax Measures towards Tax Compliance Behavior: A survey on Self-Employed Taxpayers in West Malaysia," *Electron. J. Bus. Manag.*, vol. 1, no. 1, pp. 56–70, 2016.
- A. B. Abdallah, B. Y. Obeidat, N. O. Aqqad, M. N. K. Al Janini, and S. E. Dahiyat, "An integrated model of job involvement, job satisfaction and organizational commitment: A structural analysis in Jordan's banking sector," *Commun. Netw.*, vol. 9, no. 1, pp. 28–53, 2016.
- M. K. H. Xin, K. G. Khai, L. S. Fong, and N. H. Chen, "Factors Affecting Individual Taxpayers' Compliance in Malaysian Tax Filing System," *Int. J. Bus. Manag.*, vol. 3, no. 9, p. 339, 2015.
- O. W. Atawodi and S. Ojeka, "Factors that affect tax compliance among small and medium enterprises (SMEs) in North Central Ni geria," *Int. J. Bus. Manag.*, vol. 7, no. 12, 2012.

THE CONCEPT OF INTELLECTUAL CAPITAL WITHIN BANKING INDUSTRY IN GCC

YAHYA AHMED SAIF ALSARHAN

UNIVERSITI SAINS ISLAM Malaysia, MALAYSIA

Abstract

This paper has been developed to provide a comprehensive explanation of the impact of intellectual capital on the performance of banking industry in GCC. This paper has provided literature and definitions with regard to the desired variables. This paper has come up with a conceptual framework that can be applied within the GCC banking industry to enhance their performance. The conceptual framework contained two independent variables that are (human capital and structural capital), while the dependent variable was banking performance.

Keywords: Intellectual Capital, Human Capital, Structural Capital, Banking Industry, and Performance

1.0 INTRODUCTION

The Gulf Cooperation Council (GCC) has founded in 1988, which gathered six countries (Saudi, Oman, United Arab of Emirates, Qatar, Kuwait, and Bahrain) that share common economic and political objectives (Al-Malkawi, Pillai, & Bhatti, 2014). The GCC countries in the global arena take advantage of some superiority thanks to their increasing power in politics and provide an advantage in the financial field with their high income from the oil and gas sectors. This effect has been distinguishable in the use of hydrocarbon revenues in international financial markets. For this reason, the GCC countries have had some privileges in the financial sector, especially as a result of the expansion of the Islamic banking and finance sector since the 2008 global financial crisis.

But, due to the sharp decline of oil and gas in late 2014, the GCC banking industry experienced a slowdown in its performance. According to Saleh, Moradi-Motlagh, and Zeitun (2020) GCC banking industry performance over the period 2014-2019 witnessed a notable slowdown performance, which is linked to the slowdown of the economy among GCC countries. These events forced the GCC governments to come out with several initiatives to diversify the economy sources, these initiatives translate into long-term visions. The GCC governments strived to reduce the dependency on oil and gas revenue, in addition, to develop the banking industry system. These visions focus on two main pillars, transform to the economy based knowledge and strengthening the corporate governance practices.

In line to adopting the economy based knowledge, the UAE vision 2021 emphasized on paying more attention toward improving the human capital (Petraatos, Ljepava, & Salman, 2020), while vision 2030 of Saudi Arabia (M. K. Khan & Khan, 2020), Qatar (Nawaz & Koç, 2020), Bahrain (Al-Azzawi & Hasan, 2019), and Kuwait (Coombe, Reinders, Littlejohn, & Tafazoli, 2019) focused on boosting the knowledge-based of the labor power. Also, Oman vision 2040 (Coombe et al., 2019) paid more concern toward improving education ability. (M. B. Khan, Iqbal, & Hameed, 2020) highlighted that GCC visions in common paid attention to developing individual knowledge, which is considered as the main component toward boosting the economy.

Banking industry considers as the main nerve of the stock market in GCC. This industry suffers of low performance over the period 2014-2019, this is due to several reasons, the slowdown of the economy in GCC, which relies more on oil and gas industry, the sharp declining of global oil and gas price led to moderate budget deficit among GCC (Nusair, Al-Khasawneh, & Restructuring, 2018), as a result of this economic shock event, the new cash flow into the GCC stock market declined monetarily. According to Al-Sartawi and Journal (2018) there is a low level of applying intellectual capital by the GCC banking industry, where banking industry in GCC relies more on tangible assets, this led to weakening the asset management within this industry. Ousama, Hammami, Abdulkarim, Finance, and Management (2019) link the low applying of intellectual capital by GCC banks to the weak level of corporate governance implementation.

According to the Securities & Investment Company (SICO), the GCC stock markets have suffered an average declining 14% to 17% in 2018 compared to 2017. In this regard, GCC countries have released its vision of 2030, which encloses enhancement clauses for widen the implementation of intellectual capital and corporate governance

practices. These enhancements aim to provide a higher level of protection for investors and shareholders (Bygautane, Gerber, & Hodge, 2016).

Khokhar, ul Hassan, Khan, Amin, and Center (2020) examined the GCC banking performance over the period 2010-2016, the result found that Bahrain and Saudi Arabia banking industry performed well compared to other GCC banking industries. Meanwhile, the UAE, Qatar, Kuwait, and Oman banking industry suffer a low performance. Khokhar et al. (2020) attributed the low banking industry performance to the lack of standardization in products and schemes as well as the level of prudence in decision-making, and operations.

The GCC countries strive to achieve an integrated economic system for the member countries. For this purpose, several meetings held periodically that discuss the latest global events that may affect the regional economy, in addition, to improve the economic system of the GCC countries.

2.0 THE AGENCY THEORY

The huge expansion during the industrial revolution in the early nineties has boosted the emergence of many giant clusters (Tricker & Tricker, 2015). The massive development in the business sector has integrated with several relevant issues such as the separation and controlling concept of the organization. In this context, numerous studies have paid attention to organizing the relationship between owners and managers within the new ownership structure (Jensen & Meckling, 1976). Furthermore, several theories such as Property theory, Agency theory, and Stewardship theory have striven to interpret the new rule of managing the company solely from owners (Honoré, Munari, & de La Potterie, 2015). Recently, the technological revolution has created new relevant issues that produced new challenges in governing organization (Christensen, 2013). Which have motivated many scholars to produce new wide lines along with the new era developments. The last decades have witnessed many cases and events that showed the weakness of governance in firms, for example; the Enron bankruptcy case in October 2011 has formed an important turning point for the corporate governance theorems, as well as the sharp decline of Nokia performance during the last decade. That calls an urgent reconsider for the relationship between the ownership and management, besides reorganizing the granted authorities to the management.

Today, the performance of the company is the first thing that investors around the world will evaluate. This is because parties interested in investing will make their investments by looking at the performance of a company first (Abdallah & Ismail, 2017). Therefore, company performance is the most important thing to encourage people to invest in a company. To ensure the company's performance improves, responsible parties need to come up with or implement new plans and procedures to update operations and transactions throughout the business life cycle.

The world is getting smaller with globalization, in other words, nowadays; a business can be done anywhere. According to the dictionary of the board, globalization refers to the phenomenon that has made the world smaller than the speed of information technology. Globalization covers many areas and is a multi-dimensional phenomenon that covers economics, politics, culture, ideology, language, and all aspects of people's lives. Globalization facilitates business activities and in turn, leads to high company performance and thus enables greater opportunities for business growth (Buallay, Hamdan, & Zureigat, 2017).

The company's performance is reflected in the financial statements reported by the company. As such, good performing companies will strengthen management for quality exposure. Performance measurement is essential for the effective management of any firm (Sarhan, Ntim, & Al-Najjar, 2019). Prior performance measurement is important for determining a company's performance (Tan, Chapple, & Walsh, 2017). It is important to determine the impact and improvement of a business's activities.

The firm's performance is significantly influenced by corporate governance. Having good corporate governance, it will increase investment volume and help maximize company funds, thus improving company performance. Corporate governance plays an important role in the growth of corporate performance. In other words, corporate governance is effective in protecting businesses from various financial challenges and facilitating the growth of corporate performance (Minichilli, Brogi, & Calabrò, 2016).

Reducing the level of firm agency conflicts that lead to increased agency costs is a potential channel through which governance initiatives can impact firm performance (Bodolica, Dupuis, & Spraggon, 2020). (Gartenberg & Pierce, 2017) observed that lowering agency costs may result in better operating and investment performance than better-performing firms. This indicates that there is a triangular relationship between corporate governance, agency costs, and firm performance, in which case it can be said that there is a relationship between corporate governance and corporate performance.

One important mechanism of corporate governance is the board of directors. The board of directors is a body of

members elected or appointed to oversee the activities of a company or organization. The board of directors is considered to be a rational, experienced, and analytical decision-maker. (Fernández-Gago, Cabeza-García, & Nieto, 2016) state that the board is responsible for overseeing the firm's financial reporting, evaluating the quality of corporate governance within the organization, and is responsible for setting the strategic direction for the company rather than evaluating the company's performance over time. The Board of Directors is also one of the most important corporate governance mechanisms that monitor and advises management in the effective management of its responsibilities in the interests of the shareholders (Fama & Jensen, 1983a). The Board of Directors is an essential element of presenting credible or unreliable financial statements.

This body is important in providing strategic direction as control over the company's managers. The Board of Directors is under the control of the Board of Directors, in turn, responsible to the shareholders through the General Meeting of Shareholders (GMS). This advisory body is expected to provide good corporate management oversight for all shareholders. This is evidenced by identifying ways to achieve the best balance between shareholder interests and good management practices (Zhou, Owusu-Ansah, & Maggina, 2018).

In Malaysia, the board is responsible for reviewing and approving the annual corporate plan for the group, which includes overall corporate strategy, retention strategies, business development, and marketing plans, IT plans, financial plans, budgets, regulatory plans, and risk management plans. They also need to review and approve strategic initiatives including restructuring or coordination of corporate business and strategic relationships. In addition, these advisory groups need to monitor the business operations team to assess whether they are being managed properly and they need to identify key risks and ensure the implementation of appropriate systems to manage those risks.

Recent studies suggest that the presence of corporate governance mechanisms will enhance management oversight and reduce incidents of mismanagement within the organization. Therefore, effective corporate governance especially the role of the board can enhance the value of the company. According to (Kao, Hodgkinson, & Jaafar, 2019), good corporate governance requires active participation from all parties, including the board in fostering continuous improvement. Lack of strong corporate governance can cause an organization's performance and internal controls to decline as all business functions are intertwined with one another. This is because the board has the authority to hire and compensate top-level managers and confirm and monitor important decisions. Therefore, this study will study in-depth the impact of the board on the characteristics of the board of directors to ensure that the value of the company remains positive. Therefore, the hypothesis of this study was developed based on the characteristics of the board of directors (CEO duality), independent board, and board size.

3.0 GCC BANKING INDUSTRY

The Gulf Cooperation Council (GCC) dominates the Islamic financial world, responsible for 90 percent of the Sharia-compatible assets of the MENA region. The top 10 Islamic banks in the region are GCC-based banks with \$ 400 billion in assets. These banks have branches abroad. The Saudi-based Islamic Development Bank operates on five continents. The bank of Bahrain, AL Baraka, serves in over 15 countries. Gulf banking markets may have entered an important stage of mergers, with the potential to reshape the role of this industry and its ability to carry out brokerage activities significantly. In January 2020, two of the largest banks in the United Arab Emirates, the National Bank of Abu Dhabi and First Gulf Bank, agreed to merge to create a leading national entity and a regional banking power center with total assets of \$ 170 billion. In the Sultanate of Oman, talks between Bank Sohar and Bank Dhofar on the merger process have reached an advanced stage. Mergers are also expected to take place in Bahrain and Qatar (Khokhar, ul Hassan, Khan, Amin, & Center, 2020).

The fact is that the continuing low oil prices pose a threat to economic growth and the sustainability of fiscal conditions in the region. This has an impact on banking systems. Banks are facing increasing pressure on liquidity to face the influx of private and public deposits abroad. This, coupled with lower interest rates under currency pegs, erodes profit margins. As for capital reserves, they are strong, but the quality of assets may deteriorate if oil prices remain low for a long time and economic growth further falls. Therefore, in an increasingly fragmented context, mergers may help achieve efficiency gains and ultimately maintain financial stability.

Nevertheless, it is important that banking mergers in the Gulf do not come at the expense of competition. International experience shows that sound banking competition generally enhances access to finance and improves the efficiency of financial intermediation without necessarily diminishing the stability of the banking system. Banking competition in the region is usually characterized by weakness, which is attributable in large part to the strict registration requirements, restrictions imposed on banking activities, the relatively weak credit information systems, and the absence of competition from foreign banks and non-banking financial institutions (Alandejani &

Asutay, 2017). While the increased concentration of markets does not necessarily mean that the markets have more strength, there is a risk that the current and expected wave of consolidation in this sector may have long-term negative impacts on competition if it is not subject to subtle meticulous development.

4.0 COMMERCIAL GCC BANKING INDUSTRY

The banking sector in any country is the true mirror of the heart of economic performance, as this sector is one of the sectors that respond quickly to economic changes and try to adapt to it quickly. To prepare for it and move in its direction even before those indicators occur its work in the local market for this sector. In the countries of the Gulf Cooperation Council, Bahrain and the UAE are among the most open to the presence of foreign banks in the local market, while the Saudi market remains relatively less open to foreign banks, despite the fact that the monetary authorities granted three licenses in recent years (Elian, 2020).

The Gulf banking sector is currently witnessing an era of its golden ages, citing the reason for this for several factors, most notably the enormous amount of financial surpluses resulting mainly from high oil prices that are specialized in its production in the countries of the region, which led to a reflection on government projects, increased business, high savings and high consumer demand (Elian, 2020). The expansion of real estate projects, which is a chain that finds the role of banks in every episode, including if the role of banks is not essential in those episodes, and it is an interlocking role that combines the advantages of dealing with economic sectors and banking services for individuals and are the two feeding sources for banks with all their consequences, so the banking sector is currently one of the most important sectors prosperity, whose prosperity led to the emergence and establishment of larger banks in the region, perhaps the most prominent of which is the Qatari Rayyan Bank, which is the largest bank in the Gulf region and the Middle East (Platonova, Asutay, Dixon, & Mohammad, 2018).

In Bahrain, Oman, the Emirates and Qatar, international banks were operating without restrictions, and recently Saudi Arabia and Kuwait opened the door wide open to these banks. In 2003, the Emirates Central Bank announced its willingness to allow foreign banks to operate on a mutual basis. As the number of foreign banks in the UAE amounts to 28 foreign banks, however, no new licenses have been issued to foreign banks for twenty years until the present time. Recently, Saudi Arabia liberalized the banking sector and issued licenses to a number of international banks, such as HSBC and Deutsche Bank, among others. Furthermore, SAMA granted Emirates Bank Group and National Bank of Kuwait operating licenses. Likewise, Kuwait has also liberalized its banking system and granted licenses to three foreign banks such as BNP Paribas, HSBC and Abu Dhabi National Bank (Naimy & Kattan, 2020).

5.0 ISLAMIC GCC BANKING INDUSTRY

The Islamic finance industry in the Gulf Cooperation Council countries is witnessing a clear development, whether in the volume of its dealings or in the mechanisms of work in Islamic financial institutions in the Gulf. The development movement witnessed in this industry heralds a promising future, especially with the growth in Sharia-compliant Gulf banks and its international expansion policy. This expansion is helped by the fact that the Gulf region is the heart of the Islamic world, as well as the global experiences that Gulf Islamic banks have gained from their partnerships with international banks. This came in a report issued by the "Kuwait Program on Development, Governance and Globalization in the Gulf States" which was prepared by Rodney Wilson, Director of Islamic Finance Program at Durham University, and visiting professor at the College of Islamic Studies in Qatar in 2019. The report begins by noting that the GCC countries are the heart of the world Islam, for the virtue of the Holy Land in the Kingdom of Saudi Arabia, in addition to the Kingdom's application of Islamic law. Hence, it is not surprising that the Gulf States are the center of the Islamic finance industry. One of the main objectives of the study is to measure the extent of the Gulf States' ability to lead that industry on the global level in light of the increasing competition, as in Malaysia, Iran, Britain and others (Naimy & Kattan, 2020).

The value of Sharia-compliant assets in the Gulf States exceeds \$262.6 billion, equivalent to 41 percent of the value of that industry globally, amounting to \$640 billion in late 2018. However, this proportion is not huge compared to it in Iran, reaching 235.3 billion. The performance of Gulf Islamic finance institutions also witnessed a remarkable development, as profit rates and returns exceeded those of Islamic banks in Iran. For example, Al-Rajhi Bank achieved the highest profits among Sharia-compliant financing institutions. The Islamic banking industry in the Gulf is characterized by being more open to the world, as the Gulf countries open their arms to Islamic windows for international banks such as HSBC - Amana along with Iranian banks. The report indicates that Islamic finance institutions in the Gulf countries are important sources of capital, and they also contribute to the development of the Islamic finance industry worldwide, especially in Asia. The Gulf countries are considered the heart of the Islamic world, which makes it the ideal center for the development of the Islamic finance industry, especially with the expansion of branches of Islamic Gulf banks around the world (Saif-Allyousfi, 2019).

6.0 INTELLECTUAL CAPITAL

Intellectual Capital (IC) is useful packaged knowledge, with which all ideas, regardless of size or scope, constitute IC, as long as they provide a benefit to the company that makes it more efficient and competitive in its development and operation. In this sense, an advance in biotechnology is as important for a company as an error-free billing system; the discovery or invention of a new product such as the modification of a process that required a month and has been reduced to a week. Edvinsson (1997) defines Intellectual Capital "as the possession of knowledge, applied experience, organizational technology, customer relations, and professional skills that offer the company a competitive advantage in the market". For Allarakhia (2018), the current environment has changed who leads the term intellectual capital to the agenda of leadership and management, and who defines it as "everything that the members of an organization know and that gives it a competitive advantage in the market". This use of the term would define the dynamic effects of the intellect of individuals, in this sense, for managers and management consultants. For these reasons, intellectual capital is the sum of all the knowledge that all the employees of a company possess and give it a competitive advantage.

the growth of a bank depends significantly on employees, who through ideas, knowledge, skills, and experience allow a company to stay active and compete in the market. However, it is important to develop new and better capacities regarding intellectual capital which allows generating competitive advantage. As a result of the correct development of intellectual capital, they have the effect of obtaining wealth, employment, positioning in the market. According to Ozkan, Cakan, and Kayacan (2017), human capital is the set of individual capacities, knowledge, skills, and experience of the organization's employees and managers. C.-H. Liu and Jiang (2020) consider that these resources can be of three types: competencies (knowledge, aptitudes, abilities and know-how), attitude (motivation and leadership capacity), and intellectual agility (innovation capacity and entrepreneurship, adaptation, and creation of synergies, etc.). Secundo, Ndou, Vecchio, and De Pascale (2020) make their conceptual contribution by considering human capital as the main driver of value creation for the organization. Adesina (2019) defines it as a generator of value and a potential source of innovation for the company, that is, the center from which the ideas of organization. In this sense, human capital is a differentiating source of competition. In this sense, Oppong and Pattanayak (2019) points out that Human Capital must be conceived as "the skills of individuals necessary to provide solutions to customers". However, this concept refers to the ability of the members of a certain company to satisfy or meet the needs of customers. Although this definition may seem acceptable from a general point of view, it is clear that it, from another perspective, has a limiting character, since it leaves out, from an internal perspective, the attitude of individuals, which also It is important when executing an action to solve a customer problem and, from an external perspective to other members or entities that may have a relationship with the company, such as financial entities, suppliers or investors.

On the other hand, organizational or structural capital is defined by Matos (2018), it is made up of three dimensions: organizational capital (the structure that supports human capital: processes, techniques, methods, computer and communication systems, databases, among others), innovation capital (protected commercial rights, intellectual property, and other intangible assets and talents used to quickly create and bring new products and services to market), and the process capital (work processes, standards).

Relational capital is drawn on the consideration that companies are not isolated systems, but, on the contrary, are related to the outside. Thus, relationships of this type that add value to the company are those that should be considered relational capital. Therefore, this type of capital includes the value generated by the company's relationships, not only with customers, suppliers, and shareholders, but with all its stakeholders, both internal and external (Gogan, Artene, Sarca, & Draghici, 2016; Lee & Lin, 2019; Meles, Porzio, Sampagnaro, & Verdoliva, 2016). In this sense, it is defined as the knowledge that is included in the relations of the organization. Viewed from another perspective, relational capital is the perception of value that customers have when they do business with their suppliers of goods or services. Along with these arguments, Aluko and Ajayi (2018) call this capital customer perspective in their model. In this sense, they analyze how value is created for the client, how their demand is satisfied, and why they pay for it. Therefore, what they seek is to identify and measure explicitly, in order to better manage the added value proposals that will be obtained with the selected customer and market segments. However, although in their model these authors explicitly limit this external or relational perspective to customers (Nielsen, Roslender, & Schaper, 2016), it can be extended to suppliers and, in general, to all the relationships that the company has with its environment. Similarly, Phillips (2019), Jordão, Melo, Pereira, and Carvalho (2017), and Delis, Iosifidi, and Tsionas (2020), consider that this dimension is mainly made up of the value generated by the company's relationships with its customers.

7.0 PERFORMANCE

The concept of performance, which is very difficult to define and define its limits, is of great importance for organizations. Because referring to Flapper et al. (1996), according to Işıl (2008), the success and continuity of an organization depend entirely on the performance of that organization. Therefore, performance measurement is vital for an organization. In this direction, it will be impossible to expect success from management that does not have any idea about the success level of the organization, in other words, the level of achievement of the organization. Based on this, it can be said that performance information is among the primary information that management needs. It is possible to find various definitions for the concept of performance in the literature. The highlights of the definitions in the literature are as follows: "Performance is the determination of the position reached in line with the plans made for a specific target in general terms, in other words, the success achieved in terms of quality and quantity" (Songur, H, 1995). It can be deduced from this definition that performance means measuring the absolute or relative level of reach to a predetermined target. In other words, it is possible to express the concept of performance as a qualitative and quantitative expression of the achievement of a previously planned goal or goals. In this direction, the existence of a predetermined goal and the evaluation of the level of achievement of this goal appear as two basic characteristics that underlie the performance.

According to Şimşek and Öge (2007) and Göktaş (2014), the concept of performance basically reveals the level of success of the employee while describing the performance level of the task or the behavior of the employee under certain conditions. For this reason, successful employees are called high performers.

Another definition of performance in the literature was made by Hatunoğlu, Bakan, and Eraslan (2011) from an individual perspective. According to this definition, performance is the result of the employee performing the work assigned to him within a certain and limited time. If the results of the employee are positive, it is inferred that the staff successfully fulfills their assigned duties and responsibilities and therefore has a high-performance level. If the results are negative, it is concluded that the staff failed or the performance level was less than desired.

Again, Hatunoğlu, Bakan, and Eraslan (2011) defined the performance, which has a versatile structure and means the measurement of variables depending on many factors, as the sum of the qualitative and quantitative contributions of an employee or team to the mission of the unit and organization to which they are affiliated. Measuring performance, outputs, and inputs used during the production of goods, when considered at the enterprise level, as well as individual performance definitions; It is also possible to define the level of achievement to a specified target, the efficiency and effectiveness of an activity whose purpose has been previously determined.

Apart from these, looking at other definitions related to performance in the literature; Akdemir (1999) expresses performance as "a concept that describes the result obtained as a result of a targeted and planned activity quantitatively and/ or qualitatively". Similarly, to this definition, Benligiray (1999) and Uçak (2007) show that the performance of the employee, unit, or organization that performs this work as a result of purposeful and planned work, qualitatively or quantitatively. It is a concept that measures". Plane (2007), which makes perhaps the simplest definition of performance, defines performance as the quantities of goods and services produced in a certain period.

8.0 THEORETICAL FRAMEWORK

According to Edvinsson (1997), intellectual capital elements consist of only two components: human capital and structural capital. The explanation of the intellectual capital elements and their sub-categories (elements) illustrated in Figure 1 as follows:

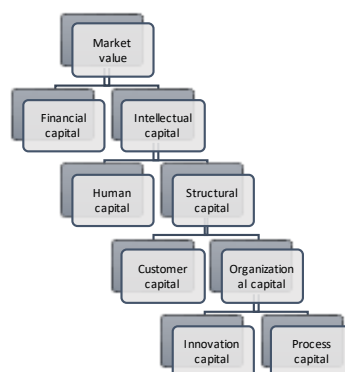

Figure 1: intellectual capital components

Source: (Edvinsson, 1997)

According to the authorities of Leif Edvinsson, Michael Malone, Pulic, the Swedish intellectual capital firm that published the first intellectual capital report, and the OECD-led authorities, human capital has the power of organizational members to fulfill their responsibilities assigned to them personally. It is a collection of the information, abilities and creativity features they use. Human capital includes the values that the organization has, its organizational culture and philosophy. Human capital is the creative power that one possesses as a result of natural talent, education and experience. In addition, according to the understanding of (Edvinsson, 1997), and Skandia firm, human capital includes the combination of human characteristics of employees working in an organization such as knowledge, skills, experience, insight and intuition. It will be understood that the human features in question are of vital importance for an organization. Therefore, one of the main objectives of today's organizations has been to make maximum use of human capital. However, it is naturally understood by the related enterprises that one of the basic conditions of making maximum use of human capital is the necessary investments in this field. (Stewart, 2010) also has an important emphasis on that: The marginal value of investing in human capital is about three times greater than the marginal value of investing in machinery. The intellectual capital elements are divided into human capital and structural capital and have sub-categories (elements); the components of human capital can be listed as follows:

- Technical knowledge (Know-how)
- Education
- Professional competence
- Studies on knowledge production
- Ability / skills building
- Entrepreneurship enthusiasm, inventor, accepting and rejecting skills
- Exchangeism

The structural capital after human capital, hardware, software, databases, organizational structure, patents, brands and other similar elements that are important factors for the efficiency of organizational members. Unlike human capital, structural capital can be owned by the enterprise and therefore can be used within the business structure of the enterprise. According to another definition of structural capital, "Structural capital is human capital. It is the formation resulting from the totalization of the systematic studies including the institutionalization of the integrated knowledge and skills and the establishment of a collective organization memory and efforts to provide financial leverage". Structural capital may present some differences between businesses.

9.0 CONCEPTUAL FRAMEWORK

According to Barney (1991), financial capital includes all monetary resources. Physical capital is the current technology of the enterprise. Human capital is about the education, experience, judgment, knowledge, communication, and understanding levels of the employees in the enterprise. Organizational capital includes formal and informal structures in business. In addition, elements such as the business culture, the reputation of the business, the relationship of the business with other businesses, and the groups within the business are included in organizational capital. In the studies conducted by Leana III and Van Buren (1999), Bontis (2003) intellectual capital is examined under three groups as human capital, structural capital, and customer capital. Structural capital is the most controversial element of intellectual capital, as it constantly changes between different models of intellectual capital. Leana III and Van Buren (1999) describe structural capital; it is classified under two groups as innovation capital and process capital. Innovation capital includes the ability of an enterprise to produce new products and services. Process capital, on the other hand, covers processes, techniques, systems, and tools in the enterprise. Barney (1997) used the concept of organizational capital instead of the concept of structural capital.

Ozkan et al. (2017) conducted an investigation for the impact of intellectual capital on the performance of 44 Turkish banks. The intellectual capital performance of banks is measured through the value-added intellectual coefficient (Subramaniam, Vaicondam, Nadarajan, & Leng) methodology. The intellectual capital performance of the Turkish banking sector is generally affected by human capital efficiency (HCE). In terms of bank types, development and investment banks have the highest average VAIC. When VAIC is divided into its components, it can be observed that capital employed efficiency (CEE) and human capital efficiency (HCE) positively affect the financial performance of banks. However, CEE has more influence on the financial performance of banks compared to HCE. Therefore, banks operating in the Turkish banking sector should use their financial and physical capital if they wish to reach a higher profitability level.

Nawaz and Haniffa (2017) measured the relationships between the basic components of intellectual capital and

profitability, productivity, and the book value of 64 Islamic financial institutions from over eight countries to market value, which are criteria of the financial performance of businesses. The results indicate a significant positive relationship between Value Added Intellectual Coefficient (Subramaniam et al., 2020) and accounting performance based on ROA. The results further indicate a significant positive relationship between accounting performance and capital employed efficiency (CEE) and human capital efficiency (HCE), but no significant relationship with regards to structural capital efficiency (SCE). Overall, the results suggest that the value creation capability of IFIs is highly influenced by HCE and CEE. It also revealed that it has an indirect effect on firm performance due to structural relationships. Vo (2018) as a result of the analysis of the relationship between intellectual capital and firm performance on banks operating in Thailand, they determined the positive effect of both the intellectual capital and physical capital of firms. The results show that bank profitability is driven mainly by capital employed efficiency to make a profit. However, human capital efficiency marginally reduces bank profitability in the current period but has positive effects on future profitability. Mohapatra et al. (2019) found similar results as a result of an analysis of banks operating in India. According to the results obtained, there is a positive relationship between intellectual capital and bank performance.

Furthermore, the current paper has come up to conclude this study with proposing the following conceptual framework as shown in Fig. 2.

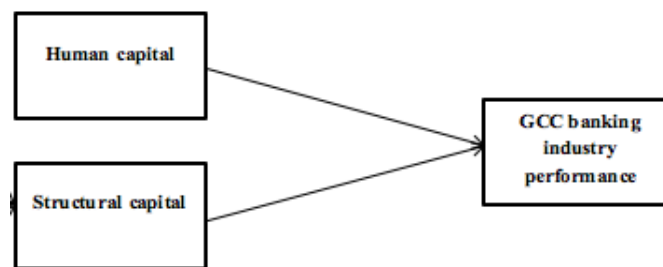

Figure 2: Unified framework for Islamic Banks Performance

10.0 CONCLUSION

It has been shown in recent decades that intellectual capital has become relevant for hundreds of companies, according to Ousama, Hammami, and Abdulkarim (2019), it is a poorly understood issue and has not led to the practice. However, in the banking sector, they have studied the subject of intellectual capital with its three variables (human capital, relational capital and structural capital) demonstrating interest in instructing the subject to improve the performance. However, the study by Mohapatra et al. (2019) concludes that the literature analyzed on human capital, structural capital, and innovation capital in the banking sector is relatively humble, compared to other economic sectors. Alongside improving the impact of intellectual capital components on the banking sector performance, the role of corporate governance in strengthening this relationship has received much attention from several literatures such as (Hamdan, Buallay, & Alareeni, 2017; Iqbal & Javed, 2017; Irawanto et al., 2017; Khan & Ali, 2018). The explanation behind that, in essence, corporate governance or board governance is the standard of rules that allows organizations to ensure that they are serving the needs of their shareholders, stakeholders, management team, and customers effectively and responsibly. However, included in this is that they are running the company in a way that meets the company's short and long-term goals. Best practices incorporate many different aspects of board work. They entail taking a critical look at the qualities and characteristics of board directors, who they are as people and the way they approach governing an organization to ensure optimal usage of the organization resources, either the physical or intellectual capital.

The main objective of this paper was to study the impact of intellectual capital on the GCC banking industry performance. The current paper has provided a comprehensive literature review about the topic of the paper. The literature review has included details about the banking industry in GCC, human capital, structural capital, and performance. This paper has also highlighted intellectual capital theory and agency theory. Based on these literature and theoretical framework, the paper was able to come up with a conceptual framework showing that human capital and structural capital have a positive impact on banking performance in GCC.

REFERENCES

- Abdallah, A. A.-N., & Ismail, A. K. (2017). Corporate governance practices, ownership structure, and corporate performance in the GCC countries. *Journal of International Financial Markets, Institutions and Money*, 46, 98-115. doi:<https://doi.org/10.1016/j.intfin.2016.08.004>.
- Alandejani, M., & Asutay, M. (2017). Nonperforming loans in the GCC banking sectors: Does the Islamic finance matter? *Research in International Business and Finance*, 42, 832-854.
- Allarakhia, M. (2018). Evolving models of collaborative drug discovery: managing intellectual capital assets. *Expert Opin Drug Discov*, 13(6), 473-476. doi:10.1080/17460441.2018.1455659
- Pillai, R., & Al-Malkawi, H.-A. N. (2018). On the relationship between corporate governance and firm performance: Evidence from GCC countries. *Research in International Business and Finance*, 44, 394-410.
- Khokhar, I., ul Hassan, M., Khan, M. N., Amin, M. F. B., & Center, I. B. (2020). Investigating the Efficiency of GCC Banking Sector: An Empirical Comparison of Islamic and Conventional Banks. *International Journal of Financial Research*, 11(1).
- Khan, S. N., & Ali, E. I. E. (2018). The Moderating Effect of Intellectual Capital on the Relationship between Corporate Governance and Companies Performance in Pakistan. *Journal of Governance and Integrity* 2 (1), 29, 55.
- Ousama, A., Hammami, H., & Abdulkarim, M. (2019). The association between intellectual capital and financial performance in the Islamic banking industry. *International Journal of Islamic and Middle Eastern Finance and Management*.
- Tricker, R. B., & Tricker, R. I. (2015). *Corporate governance: Principles, policies, and practices*: Oxford University Press, USA.
- Jensen, M. C., & Meckling, W. H. (1976). Theory of the firm: Managerial behavior, agency costs and ownership structure. *Journal of Financial Economics*, 3(4), 305-360.
- Honoré, F., Munari, F., & de La Potterie, B. v. P. (2015). Corporate governance practices and companies' R&D intensity: Evidence from European countries. *Research policy*, 44(2), 533-543.
- Christensen, C. (2013). *The innovator's dilemma: when new technologies cause great firms to fail*: Harvard Business Review Press.
- Buallay, A., Hamdan, A., & Zureigat, Q. (2017). Corporate governance and firm performance: evidence from Saudi Arabia. *Australasian Accounting, Business and Finance Journal*, 11(1), 78-98.
- Sarhan, A. A., Ntim, C. G., & Al-Najjar, B. (2019). Board diversity, corporate governance, corporate performance, and executive pay. *International Journal of Finance & Economics*, 24(2), 761-786.
- Tan, D. T., Chapple, L., & Walsh, K. D. (2017). Corporate fraud culture: Re-examining the corporate governance and performance relation. *Accounting & Finance*, 57(2), 597-620.
- Minichilli, A., Brogi, M., & Calabrò, A. (2016). Weathering the storm: Family ownership, governance, and performance through the financial and economic crisis. *Corporate Governance: An International Review*, 24(6), 552-568.
- Bodolica, V., Dupuis, D., & Spraggon, M. (2020). At the intersection of corporate governance and performance in family business settings: Extant knowledge and future research. *Business Ethics: A European Review*, 29(1), 143-166.
- Fernández-Gago, R., Cabeza-García, L., & Nieto, M. (2016). Corporate social responsibility, board of directors, and firm performance: an analysis of their relationships. *Review of Managerial Science*, 10(1), 85-104.
- Fama, E. F., & Jensen, M. C. (1983a). Agency problems and residual claims. *The Journal of Law and Economics*, 26(2), 327-349.
- Zhou, H., Owusu-Ansah, S., & Maggina, A. (2018). Board of directors, audit committee, and firm performance: Evidence from Greece. *Journal of International Accounting, Auditing and Taxation*, 31, 20-36.
- Kao, M.-F., Hodgkinson, L., & Jaafar, A. (2019). Ownership structure, board of directors and firm performance: evidence from Taiwan. *Corporate Governance: The International Journal of Business in Society*.
- Elian, M. (2020). Determinants of off-balance sheet business in the case of GCC banking sectors. *International Journal of Banking and Finance*, 9(3), 46-68.
- Platonova, E., Asutay, M., Dixon, R., & Mohammad, S. (2018). The impact of corporate social responsibility disclosure on financial performance: Evidence from the GCC Islamic banking sector. *Journal of Business Ethics*, 151(2), 451-471.
- Naimy, V., & Kattan, R. (2020). The impact of the recent oil price decline on the GCC banking system. *Middle East Development Journal*, 1-14.
- Edvinsson, L. (1997). Developing intellectual capital at Skandia. *Long Range Planning*, 30(3), 366-373.
- Ozkan, N., Cakan, S., & Kayacan, M. (2017). Intellectual capital and financial performance: A study of the Turkish Banking Sector. *Borsa Istanbul Review*, 17(3), 190-198. doi:<https://doi.org/10.1016/j.bir.2016.03.001>
- Secundo, G., Ndou, V., Vecchio, P. D., & De Pascale, G. (2020). Sustainable development, intellectual capital and technology policies: A structured literature review and future research agenda. *Technological Forecasting and Social Change*, 153, 119917. doi:<https://doi.org/10.1016/j.techfore.2020.119917>
- Adesina, K. S. (2019). Bank technical, allocative and cost efficiencies in Africa: The influence of intellectual capital. *The North American Journal of Economics and Finance*, 48, 419-433. doi:<https://doi.org/10.1016/j.najef.2019.03.009>
- Oppong, G. K., & Pattanayak, J. K. (2019). Does investing in intellectual capital improve productivity? Panel evidence from commercial banks in India. *Borsa Istanbul Review*, 19(3), 219-227. doi:<https://doi.org/10.1016/j.bir.2019.03.001>
- Matos, F., Vairinhos, V., Selig, P. M., & Edvinsson, L. (2018). *Intellectual Capital Management as a Driver of Sustainability: Perspectives for Organizations and Society*. UK: Springer.
- Gogan, L. M., Artene, A., Sarca, I., & Draghici, A. (2016). The Impact of Intellectual Capital on Organizational Performance. *Procedia - Social and Behavioral Sciences*, 221, 194-202. doi:<https://doi.org/10.1016/j.sbspro.2016.05.106>
- Lee, C.-C., & Lin, C.-K. (2019). The major determinants of influencing performance from the perspective of intellectual capital: Evidence on CPA industry. *Asia Pacific Management Review*, 24(2), 124-139. doi:<https://doi.org/10.1016/j.apmr.2018.01.006>
- Meles, A., Porzio, C., Sampagnaro, G., & Verdoliva, V. (2016). The impact of the intellectual capital efficiency on commercial banks performance: Evidence from the US. *Journal of Multinational Financial Management*, 36, 64-74. doi:<https://doi.org/10.1016/j.mulfin.2016.04.003>
- Aluko, O. A., & Ajayi, M. A. (2018). Determinants of banking sector development: Evidence from Sub-Saharan African countries. *Borsa Istanbul Review*, 18(2), 122-139. doi:<https://doi.org/10.1016/j.bir.2017.11.002>
- Nielsen, C., Roslender, R., & Schaper, S. (2016). Continuities in the use of the intellectual capital statement approach: Elements of an institutional theory analysis. *Accounting Forum*, 40(1), 16-28. doi:<https://doi.org/10.1016/j.accfor.2015.11.002>
- Phillips, E. (2019). Nassim Taleb heads international banking's first Grey/Black Swan Committee. *The Quarterly Review of Economics and Finance*, 72, 117-122. doi:<https://doi.org/10.1016/j.qref.2018.11.005>
- Jordão, R. V. D., Melo, V. L. T., Pereira, F. C. M., & Carvalho, R. B. d. (2017). Intellectual capital in mergers and acquisitions: a case study in a world-class financial institution. *Revista de Administração*, 52(3), 268-284. doi:<https://doi.org/10.1016/j.rausp.2017.05.007>
- Delis, M. D., Iosifidi, M., & Tsionas, M. (2020). Management estimation in banking. *European Journal of Operational Research*, 284(1), 355-372. doi:<https://doi.org/10.1016/j.ejor.2019.12.023>
- Bontis, N. (2003). Intellectual capital disclosure in Canadian corporations. *Journal of human resource costing & accounting*, 7(1), 9-20.

- Leana III, C. R., & Van Buren, H. J. (1999). Organizational social capital and employment practices. *Academy of Management review*, 24(3), 538-555.
- Barney, J. (1991). Firm resources and sustained competitive advantage. *Journal of Management*, 17(1), 99-120.
- Nawaz, T., & Haniffa, R. (2017). Determinants of financial performance of Islamic banks: an intellectual capital perspective. *Journal of Islamic Accounting and Business Research*.
- Subramaniam, M., Vaicondam, Y., Nadarajan, D., & Leng, Y. L. J. I. J. o. P. R. (2020). *Sociology of Individual Voluntary Tax Compliance* 24(01).
- Mohapatra, S., Jena, S. K., Mitra, A., & Tiwari, A. K. (2019). Intellectual capital and firm performance: evidence from Indian banking sector. *Applied Economics*, 51[1], 6054-6067.
- Hamdan, A. M., Buallay, A. M., & Alareeni, B. A. (2017). The moderating role of corporate governance on the relationship between intellectual capital efficiency and firm's performance: evidence from Saudi Arabia. *International Journal of Learning and Intellectual Capital*, 14(4), 295-318.
- Iqbal, M., & Javed, F. (2017). The Moderating Role of Corporate Governance on the Relationship between Capital Structure and Financial Performance. *International Journal of Research in Business and Social Science* (2147-4478), 6(1), 89-105.
- Irawanto, D. W., Gondomono, H., & Hussein, A. S. (2017). The effect of intellectual capital on a company's performance moderated by ITS governance and IT strategy integration employed by bank listed in Indonesian stock exchange. *The South East Asian Journal of Management*.

THE RELEVANCE OF ISLAMIC FINANCING INSTRUMENTS ON COVID 19 RECESSION IN NIGERIA

AKINTAN, I, & DABIRI, M

Department of Business and Finance, Crescent University, Abeokuta, Nigeria.

ABSTRACT

This study examined the relevance of Islamic financing Instruments on COVID 19 Recession as it affects different sectors of the economy in Nigeria. A comparative analyses of the Islamic Finance Instruments such as Musharakah, (Equity Sharing) ,Mudarabah, (Silent partnership),Murabahah(Cost Plus),Salam, (Forward Sale) , Istisna (Manufacturing Financing), Ijarah (Leasing), Sukuk (Investment Certificate), Muzara'ah, (Agricultural Partnership) Al-Musaqat, (Contract of Irrigation) Qard Hassan (Beneficence Loans) ,Wakalah, (Agency contract) Kafalah (Suretyship Contract) and Ju'ala (Service Agency) were employed to revealed their significance in sourcing funds for various sectors of the Economy. This paper relies heavily on secondary data through literature reviews and research works of authors and researchers on Islamic Finance and Economic Recession; and concluded that Sukuk, Ijarah, Murabahah, Muzara'ah, Al-Musaqat, Salam, Qard Hassan, Istisna, Musharakah, Mudarabah, Wakalah, and Kafalah financing modes were essential to providing alternative sources of financing the Economy during recession. We recommended that Islamic Banks should be aggressive in promoting the usefulness of the Islamic Financing instruments to Governments, Manufacturing Companies, firms and Small Business owners in order to cushion the negative effects of POST COVID 19 Recession on the Economy.

Keywords: Islamic finance, Economy, Recession, Musharakah, Muzara'ah, Istisna, Sukuk, Kafalah.

1.0 INTRODUCTION

Islamic finance has emerged as an effective tool for financing development worldwide, including in non-Muslim countries. Major financial markets are discovering solid evidence that Islamic finance has already been mainstreamed within the global financial system and that it has the potential to help address the challenges of ending extreme poverty and boosting shared prosperity. (World Bank, 2015)

According to Price Water House Coopers report (2013) revealed that the demand for Islamic finance services is increasing due to growing Muslim populations in South America, Asia, Africa and Middle East which currently account for over 95% of the world's Islamic population and which are projected to grow 35% by 2030. The SAAAME countries also contain large unbanked populations, which can be harnessed by Islamic banking models. Furthermore, the Global Islamic finance report of (2017) found out that the annual turnover of the Islamic finance market is estimated at 2.293 trillion US dollars, which is 1% of all world assets, and average growth rate of World Islamic finance is 13,9% between 2009-2017.

Islamic finance is a model that comply with Islamic principles, known as Shariah or Islamic law, based mainly upon the prohibition of riba (interest), speculation, gharar (excessive risk), unjustified enrichment, maysir (gambling), and other unethical practices. Moreover, Islamic finance is also based upon asset-backing tenets, i.e., each financial transaction must be tied to a tangible, identifiable underlying asset; sanctity of contracts; profit sharing, risk sharing, and other Shariah-compliant principles. (Djebbar 2011)

A core underpinning of Islamic finance is the tenet that requires Islamic financial transactions to be supported by genuine productive economic activity. Islamic finance is also a financial regime that places emphasis on risk-sharing, thereby strengthening further the link of finance to the real economy. (Zeti, Akhtar Aziz, 2013).

Moreover, Hassan and Lewis (2007) identify the following basic types of Islamic financial instruments in Islamic banking as Musharakah (partnership), Mudaraba (finance by way of trust), Murabaha (cost-plus financing), Ijara (leasing), Salam (advance purchase), Bai bi-thamin ajil (deferred payment financing), Istisna (commissioned manufacture) and Sukuk (participation securities).

On the other hand, the Global Pandemic as a result of Corona Virus outbreak which started in the Wuhan province of China in December 2019 had further plundered the economies of developed, developing and underdeveloped Countries into recession and economic down turn which is noticeable in the low level of economic activities, contraction in the Business Cycle, high level of unemployment, inflation and job loss e.t.c. This is tandem with the

position of International Monetary Fund's on a looming severe contraction of the economy by year-end 2020.

Whereas, the last global financial crisis of 2007 that led to recession was triggered by the United States housing bubble; excessive lending of banks into high-risk subprime and adjustable rate mortgages resulted in high default rates as well as downfall of banking sector. This resulted in the fall of global GDP, rising unemployment and economic difficulties in many parts of the world (Kamar, 2012).

According to Central Bank of Nigeria (2012) Recession is a business cycle contraction, and it refers to a general slowdown in economic activity for two consecutive quarters. During recession, there is usually a decline in certain macroeconomic indicators such as GDP, employment, investment spending, capacity utilization, household income, business income, and inflation, with the attendant increase in the rate of unemployment. Similarly, Kimberly.(2006), defines recession as when the economy declines significantly for at least six months. It means there is a drop in the following economic indicators: Real Gross Domestic Product (GDP), Income level of individual and revenue generation of government, Employment, Manufacturing and Retail sales. According to Study.com, a recession is a general downturn in an economy which is associated with high unemployment, slowing gross domestic product and high inflation. In addition, recession will typically be characterized by high unemployment, falling average incomes, increased inequality and higher government borrowing, etc (Tejvan, 2011).

Moreover, Chloe. D.(2020) wrote an article and quoted Avman Amin Seiny, the CEO of the Islamic Corporation for the Development of the Private Sector pointing out that the global COVID-19 pandemic crisis is an economic crisis that will affect the financial system which the magnitude and management will be different from 2008. Although, Islamic banks and financial institutions emerged largely unscathed from the 2008 crisis thanks to prohibitions against speculation and risky asset classes but could see big losses soon because of the way the pandemic's consequences are hitting the poor and small businesses. It was also observed that in many Asian and African countries, Islamic finance has large market share in micro finance, small- and medium-sized enterprise (SME) and retail lending which means the pandemic portends big impact on SMEs, low income and minimum wage individuals while corporate bodies have large cushions of capital and government support. However, in the Gulf Cooperation Council (GCC), the asset mix is different, much of the economy is driven by government spending on infrastructure and there is more exposure to real estate. A decline in oil revenue means a cut back on these projects and directly affects all financial institutions.

Nigeria's first full year recession began in the year 1987 with output contracted to 0.4 percent in the first quarter from a year earlier, and 0.7 percent point in the fourth quarter (Bohlund, 2016). In 2006, there occurred a recession called the bursting of the real estate bubble on the summer which originally led to the bankruptcy of a large number of floating rate mortgages and then moved to the market of corporate subordinated bonds issued to finance securitized mortgages. The outcome was a wave of collapse, mergers, and privatizations after September 2008. The 2008 recession is said to be one of the major economic recessions called subprime mortgage crisis. The consequence of the subprime crisis gave birth to instant movement to the financial markets of other countries causing a surprise decline of 40 to 70% (my accounting course, 2017).

Furthermore, during the 2016 recession in Nigeria, it was almost widely believed that unexpected and sustained decline in oil price was the most important cause of recessions in Nigeria. The monetary authority in Nigeria defended the local currency from forced devaluation against the dollar and adopted a managed float foreign exchange system, which worked well from 2016 to 2019. (Ozili, P.2020). Surprisingly, nobody thought that a public health crisis could trigger an economic crisis in the country. Ozili, P.(2020) opined that the 2020 economic crisis is different from other economic crises or recessions in Nigeria because most economic agents, who should have helped to revive the economy, were unable to engage in economic activities due to fear of contracting the Covid-19 disease, while other economic agents did not engage in economic activities when the government imposed and enforced its social distancing policy and lockdown of movement in Abuja, Lagos and Ogun states on the 30th March 2020. Thus the objective of this study is to examine the relevance of Islamic Financing instruments in providing alternative funding to cushion the negative effect of recession in affected sectors of the Nigerian economy.

1.1 Research Problem And Objectives

Few studies have examined the relevance of Islamic financing instruments on Recession. To fill this gap in literature, this paper investigates the potential effects of Islamic financing instruments on Recession in Nigeria. We believe that the results of this paper will help decision makers and finance scholars to understand the usefulness of Islamic financing instruments, and their role in ensuring recovery of the economy from Recession.

2.0 LITERATURE REVIEW OF ISLAMIC FINANCE AND RECESSION

Warde, I. (2000) defines Islamic finance as all financial practices that are based, in their objectives and operations, on Qu'ranic principles. Chartered Institute of Management Accountant (2015) refers to Islamic finance as a term that reflects financial business that is not contradictory to the principles of the Shari'ah. According to Jobst (2007) Islamic finance is a financial relationship involving entrepreneurial investment which is subject to moral prohibitions. Islamic finance is based on principles that prohibit risk taking, interest earning, sinful activities, gambling, speculative trade and money lending to customers. It believes in trading based on real goods and services and a reward-sharing contract. It also focuses on providing an ethical financial system with a motive of wealth redistribution, which will have a long-term effect on poverty alleviation (Hayat, 2009).

In the same vein, Islamic finance operates on the basis of Shari'ah principles by observing the pillars and conditions of contract in the operational mechanism. Its grounding principles are the objectives of Shari'ah (Maqāṣid al-Shari'ah): to realise human well-being (Maṣlahah) and to repel harms and difficulties (Mafṣadah) in people's lives (Laldin and Furqani 2012). In addition, Akram (2014) posits that Islamic finance integrates ethics into finance by prohibiting unethical investment practices and activities such as Riba (usury), Gharar (uncertainty), Maisir (gambling), Zulm (oppression), Tadlis (cheating) and others, while emphasising justice and fairness (Adl) and equality (Musawah) in financial transactions. Islamic finance works on the basis of partnership and co-operation among the financiers and investors/entrepreneurs, with risk and reward sharing, which ensure greater market discipline. It inculcates greater transparency and disclosure, and greater fiduciary duties and accountability, for the benefit of both the financiers and the customers. Moreover, Islamic finance ties financial transactions to real economic activities, since it prohibits that money becomes a commodity or an end in itself. Islamic finance bans excessive leverage that has no direct link to real economic activities and promotes trade in real assets and that have returns commensurate with risks. Islamic finance prohibits usury, gambling, uncertainty, and trading in unlawful goods. It also establishes a financial system that enhances justice and welfare for all stakeholders at macro and micro levels.

The National Bureau of Economic Research (NBER) (2008) defined a recession as a "significant decline in economic activity spread across the economy, lasting more than a few months, normally visible in a real gross domestic product (GDP), real income, employment, industrial production and wholesale-retail sales". According to (CBN 2012) Recession is a business cycle contraction, and it refers to a general slowdown in economic activity for two consecutive quarters. During recession, there is usually a decline in certain macroeconomic indicators such as GDP, employment, investment spending, capacity utilization, household income, business income, and inflation, with the attendant increase in the rate of unemployment. Moreover, according to Tejvan (2011) there are several problems induced by economic recession such as: Falling Output which means that less will be produced resulting to lower real GDP and lower average incomes, Wages tend to rise much more slowly or not at all, Unemployment especially a rise in cyclical unemployment, High Government borrowing which leads to higher interest rates costs, Devaluation in Exchange rate and others such as falling asset prices, falling share prices, social problems associated with rising unemployment; increased inequality, etc.

2.1 Principles Of Islamic Financial System

According to Iqbal, Z and Mirakhor, A., (2011) the following are the basic principles of Islamic Financial System:

- i. Prohibition of Interest. The central tenet of the system is a prohibition of riba, a term literally mean "an excess" and interpreted as "any unjustifiable increase of capital whether in loans or sales." More precisely, any positive, fixed, predetermined rate tied to the maturity and the amount of principal (guaranteed regardless of the performance of the investment) is considered riba and is prohibited. The direct implication of prohibition of interest is the prohibition of pure debt security with a predetermined interest rate. This prohibition is based on arguments of social justice, equality, and property rights. Islam encourages the earning of profits, but forbids the charging of interest because profits, determined after business operation, symbolize successful entrepreneurship and creation of additional wealth, whereas interest, determined before business operation, is a cost that is accrued irrespective of the outcome of business operations and may not create wealth in the event of business losses. Social justice demands that borrowers and lenders share rewards as well as losses in equitable manner and that the process of wealth accumulation and distribution in the economy be fair and representative of true productivity.
- ii. Risk Sharing: This means that the provider of financial capital and the entrepreneur share business risks in return for shares of the profits and losses, which make suppliers of funds, become investors instead of creditors.
- iii. Asset-Based Transactions: The prohibition of debt and encouragement of risk sharing suggests a financial system where there is a direct link between the real and the financial sector. As a result, the system promotes linking

financing directly with the underlying asset so that the financing activity is clearly and closely identified with the real sector activity. There are strong linkages between the performance of the asset and the return on capital used to finance it.

iv. Money as “Potential” Capital: This means that Money becomes actual capital only when it joins with other resources to undertake a productive activity. Islam recognizes the time value of money, but only when it acts actively as capital, not when it is “potential” capital.

v. Prohibition of Speculative Behavior: The Islamic financial system discourages hoarding and prohibits transactions featuring extreme uncertainties, gambling, and risks.

vi. Sanctity of Contracts and Preservation of Property Rights: Islam upholds contractual obligations and the disclosure of information as a sacred duty. This feature is intended to reduce the risk of asymmetric information and moral hazard. Islam places great importance on preservation of property rights; defines a balance between rights of individuals, society, and the state; and strongly prohibits encroachment of anyone’s property rights.

2.2 Principles Governing Islamic Finance

Specifically, according to Asghar and Rima (2015) identify the following three key principles governing Islamic Finance:

i. Principle of Equity: The principle of equity is the rationale for the prohibition of riba and the basis for prohibiting excessive uncertainty (gharar) as manifested by contract ambiguity or elusiveness of payoff. It means that transacting parties have a moral duty to disclose information before engaging in a contract, thereby reducing information asymmetry; otherwise the presence of gharar would nullify the contract. The principle of equity and wealth distribution is also the basis of a 2.5 percent levy on cash or in-kind wealth (zakat), imposed by Shari’ah on all Muslims who meet specific minimum levels of income and wealth to assist the less fortunate and foster social solidarity.

ii. Principle of Participation: According to a key Shari’ah ruling that “reward (i.e. profit) comes with risk taking,” This principle stipulates that investment return has to be earned in tandem with risk-taking and not with the mere passage of time, which is also the basis of prohibiting riba. Thus, return on capital is legitimized by risk-taking and determined ex post based on asset performance or project productivity, thereby ensuring a link between financing activities and real activities. The principle of participation lies at the heart of Islamic finance, ensuring that increases in wealth accrue from productive activities.

iii. Principle of Ownership: This principle mandates asset ownership before transaction which support the rulings of “do not sell what you do not own” (for example, short-selling) and “you cannot be dispossessed of a property except on the basis of right”. Islamic finance thus, comes to be known as asset-based financing, forging a robust link between finance and the real economy. It also requires preservation and respect for property rights, as well as upholding contractual obligations by underscoring the sanctity of contracts.

2.3 Islamic Financing Instruments

According to Asghar and Rima (2015) Islamic Financing instruments falls under one of the three categories: (a). Profit-and-Loss Sharing Products (PLS), (b). Non- Profit-and-Loss Sharing (PLS) products and (c). Fee- based products.

(a) Profit-and-Loss Sharing Products

Profit-and-Loss Sharing Products financing is closest to the spirit of Islamic finance when compared with Non-PLS financing, its core principles of equity and participation, as well as its strong link to real economic activities, helps promote a more equitable distribution of income, leading to a more efficient allocation of resources. There are two types of PLS financing: Musharakah and Mudârabah.

i. **Musharakah** is a profit-and-loss sharing partnership and the most authentic form of Islamic financing. It is a contract of joint partnership where two or more partners provide capital to finance a project or own real estate or movable assets, either on a permanent or diminishing basis. Partners in Musharakah have a right to take part in management; they seem to bear the greatest risk among all Islamic financing modes with the potential for earning the highest reward. However, whereas profits are distributed according to pre-agreed ratios, losses are shared in proportion to capital contribution.

ii. **Mudârabah** is a profit-sharing and loss-bearing contract where one party supplies funding (financier as principal) and the other provides effort and management expertise (Mudarib or entrepreneur as agent) with a view to generating a profit. The share in profits is determined by mutual agreement but losses, if any, are borne entirely by

the financier, unless they result from the mudarib's negligence, misconduct, or breach of contract terms. Mudârabah is sometimes referred to as a sleeping partnership because the Mudarib runs the business and the financier cannot interfere in management, though conditions may be specified to ensure better management of capital. Islamic banks mainly make use of Mudârabah financing to raise funds; mudârabah contracts are also used for the management of mutual funds.

iii. **Musharakah/Mudarabah:** It is particularly suitable for consignment-based trade transactions, for short-, medium- and long-term project financing, import financing, pre-shipment export financing and working capital financing. Project financing can be conducted under Musharakah through the issuance of Sukuk.

iv **Diminishing Musharakah:** It is used for financing of fixed assets like houses, motor vehicles, machinery, etc. In particular, it is suitable for financing the purchase, construction and renovation of houses and commercial buildings. It may also involve "sale and leaseback" arrangements in cases where the property is already in the ownership of the customer.

iv. **Muzara'ah:** according to Kahf and Fahim (1992), Muzara'ah is defined as a participatory form of financing between the farmer and financier with the agreement to share the output in accordance with pre-determined ratio. Similarly, it can also be defined a type of agricultural partnership contract where the contracting parties agreed to contribute between the factors of farming production and share the yield on a pre-agreed ratio after harvest (Yaacob, 2013). Due to the participatory nature of muzara'ah, the provider of capital acts as a partner and possesses every right to closely supervise the activities of the entity being financed, a practice that is different from the conventional loan. The participation of financier in the management decision will minimize losses and moral hazard that are part of the causes of the failure of the various microfinance and government loan policies. Consequently, empirical studies prove the practice of muzara'ah as beneficial and most compatible mode of financing agricultural production in countries like Malaysia, Indonesia, Egypt, Yemen, Sudan, Pakistan et cetera, particularly in rice farming, either by governments in their policy to enhance food security or by commercial institutions and other corporate bodies, the practice proved successful in alleviating poverty, promoting food security, achieving economic well-being of farming society, social brotherhood, and justice (Khasanah et al., 2013).

The provision of funds for firms to enter into Muzara'ah contract with farmers will help incorporate the principle of partnership into their operations and eliminates the problems of collateral and high interest rate imposed by the relevant institutions. The second benefit is that, it helps to eliminate the exploitation of the middlemen. This is because, it is very common for the farmers in the rural areas to go to the middlemen or to resort to their well to do neighbours to supply their surplus grains, which they do at a very low price. These middlemen capitalize on the weakness of the farmers who are in dire need of money, and hence they buy the products from the farmers at exploitative price. The third benefit is that, the model helps in increasing yield and quality of the produce. The Muzara'ah concept was applied through the Islamic banks in Sudan through Musharakah and Mudarabah Islamic principles. In the case of Musharakah, it is done in two forms. The first form of Musharakah is when banks provide small farmers with fixed assets such as tractors, ploughs, water pump and inputs (e.g. seeds, fertilizers and 10 pesticides). Farmers in turn contribute their land, labour, part of the running expenses and management, and the profit or loss are shared according to equity share after the deduction of the cost for management services rendered by the farmers. The second form of Musharakah is when banks provide land and machinery to farmers to cultivate, and the outputs are shared in pre-arranged proportions. The Mudarabah form of Muzara'ah occur when banks act as principals by providing all capital resources while the farmers contributed only in the form of expertise and the profits are shared according to pre-agreed term. Below are the procedure of operating Muzara'ah financing :

- i. The institution provides financing facility (through Cash Waqf) for farmers via partnership contract
- ii. The institution also provides necessary inputs and logistic related to agriculture in addition to the provision of agricultural, managerial and marketing expertise, and macro and micro data while the farmers contribute in the form of labour (and or land).
- iii. After harvesting, the agriculture output is sent to the market with the logistic support from the Waqf institution.
- iv. The profit/loss from the sales will then be distributed between the two parties based on a predetermined profit and loss sharing ratios
- v. Al-Musaqat- is a type of partnership contract in which the bank provides the garden and hand it over to the farmer for a certain period, then the bank gets the profit share (keshavarzi bank, 2015). Therefore, it is a partnership between a capital provider and a worker with the capital being the trees themselves, and the work being the irrigation and any related activities. the worker would receive compensation in the form of the fruits produced by the trees subject matter of the irrigation contract. it is a contract of irrigation or more specifically useful in fruit farming partnership.

(b) Non- Profit-and-Loss Sharing (PLS) Financing Products

Non-Profit-and-Loss Sharing (PLS) Financing Products contracts are most common in practice. They are generally used to finance consumer and corporate credit, as well as asset rental and manufacturing. Non-PLS financing instruments include Murâbahah, Ijārah, Salam, Istisna' and Sukuk.

i. Murâbahah: This is a popular Shari'ah-compliant sale transaction mostly used in trade and asset financing. The bank purchases the goods and delivers them to the customer, deferring payment to a date agreed by the two parties. The expected return on Murâbahah is usually aligned with interest payments on conventional loans, creating a similarity between Murâbahah sales and asset-backed loans. However, Murâbahah is a deferred payment sale transaction where the intention is to facilitate the acquisition of goods and not to exchange money for more money (or monetary equivalents) over a period of time. Unlike conventional loans, after the Murâbahah contract is signed, the amount being financed cannot be increased in case of late payment or default, nor can a penalty be imposed, unless the buyer has deliberately refused to make a payment. Also, the seller has to assume any liability from delivering defective goods.

ii. Ijārah is a contract of sale of the right to use an asset for a period. It is essentially a lease contract, whereby the lessor must own the leased asset for the entire lease period. Since ownership remains with the lessor, the asset can be repossessed in case of non-payment by the lessee. However, the leaser is also responsible for asset maintenance, unless damage to the leased asset results from lessee negligence. This element of risk is required for making Ijārah payments permissible. A variety of Ijārah takes a hire-purchase form, whereby there is a promise by the leaser to sell the asset to the lessee at the end of the lease agreement, with the price of the residual asset being predetermined. A second independent contract gives the lessee the option to buy the leased asset at the conclusion of the contract or simply return it to the owner.

iii. Salam is a form of forward agreement where delivery occurs at a future date in exchange for spot payment. Such transactions were originally allowed to meet the financing needs of small farmers as they were unable to yield adequate returns until several periods after the initial investment. A vital condition for the validity of a Salam is payment of the price in full at the time of initiating the contract, or else the outcome is a debt-against-debt sale, which is strictly prohibited under Shari'ah. The subject matter, price, quantity, and date and place of delivery should be precisely specified in the contract. In the event that the seller can neither produce the goods nor obtain them elsewhere, the buyer can either take back the paid prices with no increase, or wait until the goods become available. Should one of the parties fail to fulfill their contract, the bank will get back its initial investment, but will have to accept the loss of profit. To reduce exposure to credit risk, the bank may ask for a financial guarantee, mortgage, advance payment, or third-party guarantee.

iv. Istisna is a mode of financing where the commodity involved is manufactured to the specifications of the purchaser. This is widely used in the housing finance sector, where the client seeks finance for the construction of a house. The financier may undertake to construct the house on a specified land either belonging to the client or purchased by the financier, on the basis of Istisna', with payment fixed in whatever manner the parties may wish. It is also widely used in infrastructure finance (Sanusi 2011). In theory, the Istisna contract could be directly between the end user and the manufacturer, but it is typically a three-party contract, with the bank acting as intermediary. Under the first Istisna contract, the bank agrees to receive payments from the client on a longer-term schedule, whereas under the second contract, the bank (as a buyer) makes progress installment payments to the producer over a shorter period of time.

vi. Sukuk is a certificate of ownership applied to an underlying asset. It can also be defined as an investment certificate that represents the ownership interest of the holder in an asset or pool of assets. In a sukuk, the issuer sells the certificate of ownership to a buyer. The buyer rents it back from the issuer based on a pre-determined rental fee. The issuer also makes a contractual obligation to buy back the bond, the contractual instrument, at a future date at par value. Sukuk can have a variety of underlying assets from which revenue streams derive. Effectively, ownership in a sukuk is partial ownership in a debt (Murabaha), asset (Ijarah), project (Istisna), business (Musharaka) or investment (multiple structures). As of July 2014, Sukuk amounts outstanding were approximately \$296b, with sovereign-issuers accounting for 36% of the total market by volume. The largest issuer is Malaysia. In June 2014, Great Britain became the first western country to issue a sovereign Sukuk and Nigeria government in 2018 raised Sukuk of 100 billion Naira for Road construction due in 2025 at a return of 15.743% with rental payment semi-annually. Furthermore, another Sukuk bond of 150 billion was raised in May, 2020 for Road Development by Nigeria government

vii. Qard Hassan (Beneficence loans): These are zero-return loans that the Qur'an encourages Muslims to make to

the needy. Banks are allowed to charge borrowers a service fee to cover the administrative expenses of handling the loan. The fee should not be related to the loan amount at maturity. The loan recipient is expected to repay the exact amount at maturity.

(c). Fee-Based Products

Islamic banks offer a wide spectrum of fee-based services using three types of contracts, Wakalah, Kafalah, and Ju'ala. They are usually auxiliary to the main Murâbahah and Mudârabah transactions, though they generate various types of fees and commissions. The fee-based services provided by Islamic banks include bank transfers, issuing letters of credit and guarantees, credit cards, and offering collection and safe-custody services, mostly used in trade financing.

i. Wakalah is an agency contract, where the account holder (principal) appoints an Islamic finance institution (agent) to carry out investment activities Al- Amine, M. (2013) claims that wakalah allows a much more efficient recycling of short-term liquidity in the Islamic banking system.

ii. Kafalah is a financial guarantee whereby the bank gives a pledge to a creditor on behalf of the debtor to cover fines or any other personal liability. It is widely used in conjunction with other financing modes or documentary credits. It is a pledge given to a creditor that the debtor will pay the debt, fine or liability. A third party becomes surety for the payment of the debt if unpaid by the person originally liable. (AAIOFI 2010).

iii. Ju'ala is essentially an arrangement where a party pays another a specified amount of money as a fee for rendering a specific service in accordance with the terms of the contract stipulated between the two parties. This mode usually applies to transactions such as consultations and professional services, fund placements and trust services (Hussain, M., Asghar, S and Rima, T, 2015).

2.4 Causes Of Recession In Nigeria

There are two main causes of recession in Nigerian economy namely:

- i. Economic Recession caused by global economic and financial crisis
- ii. Economic Recession caused by other Nigerian factors.

i. Economic Recession Caused by Global Economic and Financial Crisis

CBN (2012), observed that in the case of Nigeria, whenever there is economic slowdown in the U.S., China, India and Europe, it normally have negative impact on the demand of Nigerian crude oil from these countries. As a result, government's revenue and spending would drop, taxes will rise, disposable income will fall and aggregate demand will fall, which in turn, affect the production of goods and services negatively and therefore, these would lead to economic recession. Another source of negative demand shocks could be sharp appreciation of the domestic currency, which encourages import and discourage export of goods and services, and causes disequilibrium in balance of trade and deterioration in the balance of payments position.

In the same vein, Supply side shocks also causes recession mainly from general increases in commodity prices as a result of an increased in cost of production especially from imported raw materials or goods. These factors are inflationary in nature. Inflation, which is the persistent general rise in prices of goods and services as a results of high cost of factor inputs, which are usually transferred to the final consumers who can only afford less quantity because of higher prices. (Ozil, P.2020)

ii. Economic Recession Caused by other Nigerian Factors

- a) **Over dependent of the Nation on Oil as a Source of Income:** According to the CBN Governor, Nigeria gets over 95% of its revenue from Oil. Ozil P. (2020) pointed out that aftermath of the 2016 recession in Nigeria, it was almost widely believed that unexpected and sustained decline in oil price was the most important cause of recessions in Nigeria. Currently, there is a sharp drop of a barrel of crude oil from \$57 proposed in 2020 budget by the Nigeria government to less than \$30 per barrel as at May 2020. This has led the federal government to borrow \$350m externally and reduced the budget to #10.8trillion.
- b) **Poor economic planning:** Poor economic planning and no concrete implementation of her economic planning is another cause of recession in Nigeria .
- c) **High Inflation Rate:** government banning the importation of certain essential agricultural products like rice without considering gestation period is error. Removal of fuel subsidy shouldn't be simultaneously with the banning of these agricultural products. Nigeria inflation rate in July 2020 stands at 12.82%.

- d) **High Interest Rate:** Interest rate charged by conventional banks is between 25 -30%. This is extremely high for firms and small scale businesses to make profits. The poor investment culminates into high rate of unemployment in the country.
- e) **High Taxation:** Nigeria government despite the COVID 19 economic slowdown did not reduce Value Added Tax of 7.5 % and recently increases Electricity tariff.

2.5 Effects Of Recession On The Nigeria Economy

The effect of recession affects all aspects of national and human life. Many people usually lost their jobs, families and governments usually adjust their budgets during recession and in the process, social activities are also affected. Thus, below are the summary of the effects of COVID19 Recession on some sectors of the economy in Nigeria by the Lagos Chamber of Commerce and Industry (2020);

- i. **Aviation:** The Nigerian aviation sector was one of the badly hit sectors by the pandemic, resulting to airlines recording loses nearly N17 billion monthly since their operations were grounded, as part of efforts to curb the spread of the virus. Similarly, as of March 2020 the International Air Transport Association (IATA) had reported an estimated revenue loss of \$252 billion in the sector globally.
- ii. **Hospitality Industry:** It is no secret that the hospitality industry is one of the sectors that have been seriously affected by the COVID-19 pandemic, with many of the employees out of work, cancellation of many bookings and the closure of many hotels. The hotels have been experiencing very low patronage even after the lock down.
- iii. **Banks and Stock Market -** The Banking sector experienced limited operations during the lock down and some banks lay off staff due to difficult operating environment which was halted by the Central Bank of Nigeria. The stock market investors lost over # 2.3trillion after the first case of corona was detected in Nigeria ,likewise the market capitalization of listed companies valued at #13.657 trillion on February,2020 depreciated by 2.349trillion to 11.308trillion on Monday,23rd March,2020.(Ozil,P.2020)
- iv. **Cinemas and Entertainment:** The Entertainment section was also affected negatively as all the film and entertainment companies had to close down for the period of the lockdown. Some of the managers in the industry lamented that movie theatres have been shut down, art exhibitions, movie premiers and musical concerts have either been cancelled or postponed which resulted to multi-billion naira worth of deals has been lost in the sector.
- v. **Oil and Gas Industry:** The Oil and Gas Sector was not spared by the pandemic as the slump in crude oil prices due to weakening global demand for Brent crude, Nigeria's benchmark grade, dropped by over 60 percent since the beginning of the year. The crash in global oil prices has necessitated the downward adjustment of the reference price of crude oil from \$57 per barrel to \$30 and further down to \$25 per barrel for the implementation of the 2020 budget. Even the intervention of OPEC and top oil-producing countries through output cut has still not impacted on oil prices or stabilized the market.
- vi. **Health sector-** the pandemic exposed the rot and the dearth of basic infrastructure in that sector. Although the federal and state governments are making tremendous efforts to provide some basic facilities and equipment needed to battle the virus, it is necessary for these governments to resolve never to pay less attention to the health sector.
- vii. **Real Estate and Construction:** With the drop in income and loss of jobs, very little interest in acquiring houses was shown by property buyers. Also, the movement restrictions and social distancing adversely affect construction activities nationwide with organizations and individuals trying to apply safety measures.
- viii. **Trade:** This sector also experienced low activities, owing to the shutdown of factories, reduced access to raw materials and commodities due to supply chain challenges. Trillions of naira worth of trade for both imports and exports through international trade was lost due to the lockdowns, seaports and border closure. As China and other foreign countries are crucial to global trade being the main suppliers and buyers of intermediate inputs, the disruptions seriously affect trade especially importation.
- ix. **Manufacturing:** The manufacturing sector witnessed shut down of production lines and factories due to the lockdown which resulted into retrenchment of staff and low consumer purchases.

- x. **Small businesses:** As a result of low demand of goods and services from households as a result of lockdown, Small business reduces production of such goods and services in order to cut cost which makes their profit to decline. So, by cutting their production, workers would be laid off in order to minimize the cost of production, there will be no buying of new equipment, no funding for research and development, no new product rollouts and general business activities would also fall. In general, recession affects both small and large business.
- xi. **Consultants and Services:** Consultants and service providers were negatively affected, as the drop in revenue by companies and even government institutions due to the economic meltdown leads to downward adjustment of budgets which negatively affect the consultants.
- xii. The Agriculture sector experienced less negative impact from COVID-19. For instance, with COVID-19 induced lockdown in some states, the joint technical task team on emergency response to COVID-19, facilitated free and unhindered movement of food, livestock and agricultural inputs and farmer's movement across the nation during the lockdown in order to avoid food crises.

2.6 Theoretical Review Of Islamic Finance And Recession

i. Theory of Interest

The Theory of Interest according to (Qureshi, 1946) looked upon finance as a social service that should be sponsored by the government like public health and education. Qureshi took this point of view since the bank could neither pay any interest to account holders nor charge any interest on loans advanced. Qureshi also spoke of partnerships between banks and businessmen as a possible alternative, sharing losses if any. No mention was made of profit sharing. Ahmad (1952) in his book Economics of Islam envisaged the establishment of Islamic banks on the basis of a joint stock company with limited liability. In his scheme, in addition to current accounts, on which no dividend or interest should be paid, there was an account in which people could deposit their capital on the basis of partnership, with shareholders receiving higher dividends than the account holders from the profits made. Like Qureshi, above, Ahmad also spoke of possible partnership arrangements with the businessmen who seek capital from the banks. It was suggested that banks should cash bills of trade without charging interest, using the current account funds.

The principle of mudaraba based on Shariah was invoked systematically by Uzair (1955). His principal contribution lay in suggesting mudaraba as the main premise for 'interest less finance'. However, his argument that the bank should not make any capital investment with its own deposits rendered his analysis somewhat impractical. Al-Arabi (1966) envisaged a finance system with mudaraba as the main pivot. He was actually advancing the idea of a two-tier mudaraba which would enable the bank to mobilize savings on a mudaraba basis, allocating the funds so mobilized also on a mudaraba basis. A pioneering attempt at providing a fairly detailed outline of Islamic finance was made in Urdu by Siddiqi in 1968. His Islamic finance model was based on mudaraba and shirka (partnership or musharaka as it is now usually called). His model was essentially one based on a two-tier mudaraba financier entrepreneur relationship, but he took pains to describe the mechanics of such transactions in considerable detail with numerous hypothetical and arithmetic examples. He classified the operations of an Islamic bank into three categories: services based on fees, commissions or other fixed charges; financing on the basis of mudaraba and partnership; and services provided free of charge.

ii. Profit and Loss Sharing Theory

In a typical Profit and Loss Sharing (PLS) arrangement, an Islamic bank provides the risk capital to a firm in which professional managers are responsible for making strategic and operational decisions. The bank shares in profits and is liable to any financial loss. There is no serious problem with this arrangement if the bank is able, and is allowed, to monitor business operations of the firm. However, proper monitoring mechanisms are yet to be devised for Profit and Loss Sharing, especially in case of Mudaraba that does not provide any control rights to the financier (the Islamic bank in this case). Fiqh literature on this issue is quite out-of-date and needs serious reconsideration. For example, Saleh (1986) lists three rights and one responsibility of the financier in a Mudaraba arrangement. The rights include ensuring that the borrowing entrepreneur (firm) complies with the terms of the contract, sharing profits, and limited liability in case of loss. The sole responsibility is handing over the Mudaraba capital. He also outlines two rights and two responsibilities of the borrower. The rights include conducting the business with an appropriate degree of freedom, and accounting decisions. The responsibilities are compliance with the terms of the contract, and liquidation of the Mudaraba business at the end of the contract. The modern use of Mudaraba as a mode of financing obviously requires more than such preliminary specification of rights and responsibilities. There

is a need for construction of standardized Profit and Loss Sharing contracts, or by-laws, in the light of the legal frameworks of Muslim countries. A prominent feature of these by-laws should be definition of the rights and obligations of various officers or groups within the organizational structure.

iii. The Keynesian Approach to Recession

The most popular approach to mitigating a recession was developed by eminent economist John Maynard Keynes. According to Keynes, recessions were the result of exogenous shocks to the economy. This means that the economy normally functions in equilibrium unless a catastrophic event of some type throws the economy off track bringing about a recession.

According to Keynes, this exogenous shock creates fear amongst producers and consumers alike. Consumers drastically reduce their consumption. As a result, producers also reduce the quantum of goods and services being produced. This leads to a downward spiral wherein lesser consumption by consumers leads to even lesser production. Also, when the quantity of goods and services being produced is reduced, people are laid off from their jobs. This accentuates the problem of less consumption.

Hence, according to Keynes, the solution to the problem is government intervention. Consumers and producers are in the grip of fear and hence act irrationally. This is the time when the government must expand its budget and start spending even more money. This increased government spending will counter the reduced consumer spending. Government spending will ensure that production is not reduced and the spiral of recession does not perpetuate.

iv. The Austrian Approach to Recession

The Austrian economists believe that recession is not the result of an exogenous shock. Instead, it is the result of bad government policies which interfere with the market and lead to poor investment decisions in the first place. For instance during this period corporations and people who have borrowed money and made investments are under the assumption that the interest rates will remain at this level during recession. However, their assumptions are historically inaccurate. It is only a matter of time before the interest rates rise again causing the economy to crash. Austrian economists believe that the root cause of the boom-bust cycle is in the artificial boom. According to them, government-induced policies are responsible for creating this artificial boom.

Also, they believe that the longer the boom is delayed, the bigger the bust. For instance, when the dot com bubble of 2001 was delayed by expansionist government policies, it led to the housing market crash of 2009. Similarly, since the housing market crash has also been delayed using government money, the economy could be heading towards something even worse.

According to the Austrian economists the government must use its tax dollars only to govern businesses. Once it starts interfering in day to day operations, it has to tax more and more in order to sustain its policies. Hence, government spending of today might stimulate the economy today. However, this very same bailout package will have to be paid back with interest tomorrow. This increased interest payment will then be considered as an “exogenous” shock by the Keynesians even though the fact of the matter is that it has been caused by government action.

3.0. RESEARCH METHODOLOGY

The qualitative method was used to review the existing literature from all resources such as academic, scholarly journals, magazines, seminars, reports, and other related literature of Islamic finance and Recession.

4.0 PRACTICAL ISLAMIC FINANCING INSTRUMENTS TO FINANCE THE ECONOMY DURING RECESSION

In the light of the need to finance various sectors of the economy during recession, the following Islamic financing instruments were proposed:

i. Transport and Infrastructural Development

The Islamic financing instrument of Sukuk especially Ijārah-based Sukuk could be used to fund the long-term transfer of an asset or service for a specified rent and term, frequently conditional on the future repurchase of the assets for an agreed price is viable and highly recommended to mitigate operating and investment risks involved in business that are long term in nature. This is tandem with the view of Asghar and Rima (2015) that Sukuk are

strategically important not only for the Islamic financial industry, but can be a significant source of financing for infrastructure development projects such as roads, railways, Airports e.t.c.

ii. Agriculture

The study carried out by Bello S.(2018) revealed that muzara'ah contract is significantly viable in providing alternative source of Agro-financing, creating more job opportunities and reducing unemployment rate by providing more lands to be cultivated which enhances food security and in turn helps in alleviating rural poverty in Kano State. Therefore, it can be replicated in other states of the Federation.

The second alternative of Islamic Financing of Agriculture is Salam which refers to a form of forward agreement where delivery occurs at a future date in exchange for spot payment. Such transactions were originally allowed to meet the financing needs of small farmers as they were unable to yield adequate returns until several periods after the initial investment.

The third alternative Agriculture Financing is Musaqtat which is a type of contract that banks provide farmers with orchards, gardens or trees which they own or which are otherwise in their possession. This is done for the purpose of gathering the harvest of the orchard or garden and dividing it in a specified ratio. The harvest may be fruits, leaves, flowers, etc., of the plants and trees in the orchard or garden. (Ausaf, A.2015)

iii. Manufacturing

Musharakah/Mudarabah financing is proposed to fund the Manufacturing sector because it is found to be suitable for consignment-based trade transactions, short-, medium- and long-term project financing, import financing, pre-shipment export financing and working capital financing. Similarly, murabahah sale is another Islamic Finance instrument that provides various types of financing, such as financing of raw materials, machinery, equipment and consumer durables as well as short-term trade financing. (Ausaf, A.2015)

iv. Housing and Construction

Mian and Sufi (2014) suggested that proper implementing Islamic finance solutions, such as a Diminishing Musharakah (partnership) structure in-home financing can serve as a stabilizing factor for both the financial and housing sectors and protect households during recessions. Another alternative of Financing Housing and Construction is Istisna contract which is widely used in the housing finance sector, where the client seeks finance for the construction of a house. The financier may undertake to construct the house on a specified land either belonging to the client or purchased by the financier, on the basis of Istisna', with payment fixed in whatever manner the parties may wish. It is also widely used in infrastructure finance (Sanusi 2011).

v. Aviation

The Aviation business often requires multiple forms of capital because of the capital intensive nature of the aircrafts, equipments, and machinery to be deployed in maintenance services, The most vital Islamic financing alternative is Ijarah. Since ownership remains with the lessor, the asset can be repossessed in case of non-payment by the lessee. However, the lessor is also responsible for asset maintenance, unless damage to the leased asset results from lessee negligence. A variety of Ijarah takes a hire-purchase form, whereby there is a promise by the lessor to sell the asset to the lessee at the end of the lease agreement, with the price of the residual asset being predetermined (Asghar and Rima 2015).

vi. Small Business

Islamic Banks can partner with Small Businesses or Entrepreneurs on Musharakah and Mudarabah financing of products and services by providing equity financing based on profit and sharing agreements which are more appropriate than conventional bank loan. Similarly, Islamic bank can also use the concept of Murabahah sale to provide funds to Small Businesses or Entrepreneurs in the areas of financing of raw materials, machinery, equipment and consumer durables as well as short-term trade. In addition, Islamic bank can offer financial guarantee in the form of Wakalah and Kafalah services especially in issuing letter of credit to importers whereby the bank gives a pledge to pay on behalf of the small scale business. Moreover, the Islamic Bank can also provide professional services such as analyzing the creditworthiness of companies, investment opportunities and carrying out bankruptcy tests on behalf of the small scale business through Ju'ala services. (Mumtaz, Asghar and Rima 2015).

Vii. Housing and Construction

Istisna is a mode of financing that is widely used in the housing finance sector, where the client seeks finance for the construction of a house. The financier may undertake to construct the house on a specified land either belonging to the client or purchased by the financier, on the basis of Istisna', with payment fixed in whatever manner the parties may wish. It is also widely used in infrastructure finance (Sanusi 2011). Another option in financing Housing according to Mian and Sufi (2014) is Diminishing Musharakah (partnership) structure in-home financing that can serve as a stabilizing factor for both the financial and housing sectors and protect households during recession.

5.0 Conclusion and Recommendation

Popoola A., (2017) posited that Islamic finance is an alternative option worth exploring to raise funds for public works, support the private sector access to finance, funding public infrastructure and empowering small business which will help bail Nigeria out of recession.

In conclusion, this study examined the relevance of Islamic financing Instruments on COVID 19 Recession as it affects different sectors of the economy in Nigeria. A comparative analyses of the Islamic Finance Instruments such as Musharakah, (Equity Sharing), Mudarabah, (Silent partnership), Murabahah (Cost Plus), Salam, (Forward Sale), Istisna (Manufacturing Financing), Ijarah (Leasing), Sukuk (Investment Certificate), Muzara'ah, (Agricultural Partnership) Al-Musaqat, (Contract of Irrigation) Qard Hassan (Beneficence Loans), Wakalah, (Agency contract) Kafalah (Suretyship Contract) and Ju'ala (Service Agency) were employed to revealed their significance in sourcing funds for various sectors of the Economy. This paper relies heavily on secondary data through literature reviews and research works of authors and researchers on Islamic Finance and Economic Recession; and concluded that Sukuk, Ijarah, Murabahah, Muzara'ah, Al-Musaqat, Salam, Qard Hassan, Istisna, Musharakah, Mudarabah, Wakalah, and Kafalah financing instruments were essential to providing alternative sources of financing the Economy during recession. We recommended that Islamic Banks should be aggressive in promoting the usefulness of the Islamic Financing instruments to Governments, Manufacturing Companies, firms and Small Business owners in order to cushion the negative effects of POST COVID 19 Recession on the Economy.

REFERENCES

- Accounting and Auditing Organization for Islamic Financial Institutions (2010) Prospects and Challenges in the Development of Islamic Finance for Bangladesh, Bahrain: Dar Al Maiman.
- Ahmad, A., (1994) Contemporary Practices Of Islamic Financing Techniques: The Islamic Research and Training Institute, 1, pp. 15-52.
- Akram, L., (2014) Prospects and Challenges in the Development of Islamic Finance for Bangladesh, Level, 5 edn., Bank Negara Malaysia: Islamic Financial Services Board.
- Al-Arabi, M., (1966) 'Al-Iqtisad al-islami wal iqtisad al- Mu[asir, ', Majma[al-Buhuth al-Islamiyah, al-Mu'tamar al- Thalith, Cairo: Al-Azhar, pp. 209-313.
- Al-Amine, M., (2013) Managing Liquidity Risk in Islamic Finance In K. Hunt-Ahmed', Contemporary Islamic Finance: Innovations, Applications, and Best Practices. New Jersey: John Wiley & Sons, Inc., pp. 121-146.
- Asghar., Shahmoradi, & Rima T. (2015). An Overview of Islamic Finance .IMF Working Paper African, European, International Monetary Fund IMF .
- Bello, S., (2018) 'Viability of Muzara'ah Contract on Agro-financing in Alleviating Rural Poverty in Kano State, Nigeria', Jurnal AL-MUZARA'AH, 6(2), pp. 91-102.
- Bohlund, M. (2016) 'Nigeria's Economy 'On Its Knees'', Business Report, 31th May.
- Central Bank of Nigeria (2015) Understanding Monetary policy Series 14, Abuja: Central Bank of Nigeria.
- Chartered Institute of Management Accountant (2015) An Introduction to Islamic Finance. Available at: https://www.cimaglobal.com/Documents/Islamic%20finance/Rebrand%20Brochures/Islamic%20Introduction%20brochure_Mar2015.pdf (Accessed: March 2015).
- Chloe, D. (2015) 'Islamic Finance Confronts Global Pandemic'. Global News and Insight for Corporate Financial Professionals, 28th May.
- Djebbar, M., (2011) 'Islamic Achievements, Prospects and Challenges;', Islamic Financial Market Eurasian Economic Review, Eurasian Economic Club of Scientists Association, Kazakhstan, Vol. 3. Economic Club of Scientists Association, Kazakhstan, Vol. 3.
- Global Islamic Finance Report (2017) Overview of The Global Islamic Finance, Dubai: Dubai Islamic Bank.
- Hassan, M. & Lewis, M., (2007) 'Islamic Finance: A System at the Crossroads?', Thunderbird International Business Review, 49(2), pp. 151-160.
- Hussain, Mumtaz, Asghar Shahmoradi, and Rima Turk. (2016). "An overview of Islamic finance." Journal of International Commerce, Economics and Policy.
- Hayat, U., (2009). Can Islamic mode influence conventional finance? , Available at: <http://pakistanization.wordpress.com/tag/islamic-finance-vs-conventional-finance/> (Accessed: 16th January).
- Iqbal, Z., & Mirakhor, A., (2011) Economic Development and Islamic Finance, Available at: <https://elibrary.worldbank.org/doi/abs/10.1596/978-0-8213-9953-8> (Accessed: 13th October).
- Kahf, M. & Fahim M., (1992) Short-Term Financing of Commodity Production in Islamic Perspective, presented at the Seventh Annual Meeting of Experts on Islamic Banking, Kuala Lumpur.
- Kamar, B., (2012) Financial Crises, Institute for Capacity Development.: International Monetary Fund.
- Khasanah, U., Salim, U., Triyuwono, I., & Irianto, G. (2013) 'The Practice of Profit and Loss Sharing System for Rice Farmers in East Java, Indonesia', International Research Journal of Finance and Economics, 9(3), pp. 1-7.
- Kimberly, A., (2016) 'Recession, Examples, Impacts and Benefits', World Money Watch.
- Lagos Chamber of Commerce and Industry (2020) 'Nigerian Economy and Traumatic Impact of Covid19 Pandemic', APA NEWS, 13th June.

- Laldin, M., & Furqani, H., (2012) 'The Objective of the Shaṛ'ah in Islamic Finance: Identifying the Ends (Maqasid) and the Means (Wasa'il)', ISRA Research Paper. No 32 Kuala Lumpur.
- Mian, A. & Amir, S. (2014) *House of Debt. How They (and You) Caused the Great Recession, and How We Can Prevent It from Happening Again.*, Chicago: University of Chicago Press.
- My accounting course.com (2017) What is an economic Recession. www.myaccountingcourse.com/accountingdictionary/economic-recession.
- Naanen, B., (2016) 'Recession: Nigeria Neglected History', Historic Society Business Day, 31th October,
- National Bureau of Economic Research (2011) NBER Macroeconomics Annual 2010, , Available at: <https://papers.nber.org/books/acem10-1> (Accessed: 11th May).
- Ozili, P., (2020) COVID-19 Pandemic and Economic Crisis: The Nigerian Experience and Structural Cause. Available at SSRN: <https://ssrn.com/abstract=3567419> or <http://dx.doi.org/10.2139/ssrn.3567419>
- Popoola, A., (2017) Post-Recession Management of the Nigerian Economy: Islamic Principles Antidotes', Nigerian Supreme Council for Islamic Affairs Article and Press Release, 29th September.
- Price Water House Coopers report (2013) on Islamic Finance Creating value Retrieved from <https://www.pwc.com/ml/en/publications/islamic-finance-capability-statement.pdf>
- Sanusi, (2011) Islamic Finance in Nigeria: Issues and Challenges Lecture at Markfield institute of Higher Education, Leicester, UK.
- Tejvan, Pettinger (2011). Problems of Recessions Economics Help.org. Oct 11 economics. The Wall street Journal (2009). What is a Global Recession? 22nd April. Wikipedia, the free Encyclopedia (2017) Global Recession Retrieved.
- Uzair, Mohammad (1955), *An Outline of Interest less Banking*, Karachi and Dacca, Raihan Publications.
- Warde, I. (2000), *Islamic Finance in the Global Economy*, Edinburgh University Press, Edinburgh.
- World Bank (2015): —Global Islamic Finance Report1, (World Bank, Washington, D.C).
- Yaacob, H. (2013). Commercializing Muzara'ah Model Contract through Islamic Finance to help Malaysian Aborigines. *International Journal of Business, Economics, and Law*, 2(3), 69-77.
- Zeti Akhtar A. (2013): Islamic Finance - Financial Stability, Economic Growth and Development Lecture at the Islamic Development Bank (IDB), Jeddah.

MODEL DANA TAMBAHAN BAGI PENAWARAN TAKAFUL MIKRO KEPADA WARGA EMAS

Asiah Kama^a, Ahmad Azam Sulaiman@Mohamad^b and Mohammad Taquiuddin
Mohamad^c

*Jabatan Syariah dan Ekonomi, Akademi Pengajian Islam,
Universiti Malaya, Malaysia*

Abstrak

Pada tahun 2030, Malaysia dijangka mencapai status negara tua apabila penduduk yang berumur 60 tahun dan ke atas meningkat seramai 5.6 juta orang iaitu 15% daripada jumlah keseluruhan penduduk. Berdasarkan statistik ini, kajian dijalankan untuk mengkaji penawaran takaful mikro kepada warga emas yang perlu ditawarkan menggunakan dana tambahan. Oleh itu, artikel ini merangka model-model dana tambahan bagi penawaran takaful mikro kepada warga emas. Metodologi kajian secara kualitatif digunakan untuk mencapai tujuan kajian yang melibatkan temu bual dengan pengawal selia syarikat takaful, tiga syarikat takaful yang menawarkan produk takaful mikro di bawah inisiatif Perlindungan Tenang dan penilai model yang melibatkan wakil industri serta dua orang ahli akademik yang terlibat sebagai penasihat syariah bagi menilai model penggunaan dana yang digunakan. Hasil dapatan kajian telah membentuk model penawaran takaful mikro menggunakan model wakaf dan endowmen, model CSR wakaf, model zakat dan dana daripada pelbagai sumber sebagai dana tambahan dalam penawaran takaful mikro kepada warga emas.

Kata Kunci: takaful mikro, warga emas, dana tambahan

1.0 PENGENALAN

Penawaran takaful mikro kepada warga emas semakin relevan untuk dibincangkan berdasarkan situasi dan keadaan warga emas yang menghadapi kesukaran di hari tua disebabkan faktor kewangan, sosial, fizikal dan psikologi (Malaysiakini, 2018). Namun, skim takaful mikro yang terdapat di pasaran kini tidak turut sama menasaskan warga emas walaupun jangka hayat penduduk di negara ini telah meningkat. Hal ini kerana warga emas mempunyai risiko tinggi dari segi umur dan tahap kesihatan (Agensi Kaunseling dan Pengurusan Kredit (AKPK), 2014). Semakin meningkat usia, semakin tinggi caruman yang perlu dibayar, sejajar dengan risiko tuntutan yang meningkat (AKPK, 2014), syarikat takaful mengambil kira risiko tersebut menyebabkan polisi yang terdapat di pasaran tidak turut sama menasaskan warga emas. Demikian, dapat dilihat terdapat diskriminasi dalam penawaran skim takaful kepada warga emas seperti yang dilaporkan oleh Institut Penyelidikan Penuaan Malaysia Universiti Putra Malaysia (Institut Penyelidikan Penuaan Malaysia Universiti Putra Malaysia, 2017). Oleh itu, artikel ini akan membincangkan model data tambahan bagi penawaran takaful mikro kepada warga emas.

1.1 Definisi Takaful Mikro dan Warga Emas

Definisi takaful mikro dirujuk daripada kajian insurans mikro. Hal ini kerana takaful mikro belum dibincangkan secara meluas. Tambahan pula, konsep penawaran insurans mikro dan takaful mikro adalah sama. Namun, terdapat perbezaan takaful dan insurans seperti yang diketahui umum iaitu takaful merupakan skim takaful yang menawarkan perlindungan yang menepati konsep Syariah dalam operasinya. Manakala insurans pula merupakan perlindungan yang menggunakan operasi secara konvensional (Jamil Ramly et al., 2010). Oleh itu, terdapat sebahagian besar rujukan dalam perbincangan asal yang merujuk kepada insurans mikro, tetapi menggunakan istilah takaful mikro dalam perbincangan kajian ini tanpa menyentuh berkaitan operasinya. Definisi takaful mikro menurut Tajudeen Olalekan Yusuf ditakrifkan sebagai takaful untuk golongan miskin (Tajudeen Olalekan Yusuf, 2012; Seiro Ito dan Hisaki Kono, 2010; Wan Norhayate Wan Daud et al., 2016). Skim ini merujuk kepada pasaran tertentu yang dikhususkan kepada kumpulan masyarakat yang mempunyai pendapatan rendah (Craig Churchill, 2007) dan golongan miskin (Fatin Nabilah Abdul Wahid dan Kamaruzaman Noordin, 2014; Vishal Pinto, 2015). Tujuan utama takaful mikro diperkenalkan adalah bagi membantu golongan yang berpendapatan rendah supaya turut mempunyai hak untuk mendapatkan perlindungan (*protection*) dan keselamatan (*security*) apabila ditimpa sebarang musibah (Sheila Nu Nu Htay and Nur Shazwani Sadzali, 2015).

Nikunj Kumar Go (2013) menyatakan takaful mikro bertujuan membantu dan bukan untuk mendapatkan keuntungan semata-mata. Definisi takaful mikro bagi Daniel J. Clarke dan Dermot Grenham (2013) merupakan takaful caruman kecil yang mempunyai potensi besar untuk meningkatkan jumlah pemegang polisi atau peserta. Istilah takaful mikro dianggap sinonim dengan bantuan bersama (James Midgley, 2012) Takaful mikro juga merupakan alat pengurusan risiko yang menanggung kerugian pemegang polisi terhadap risiko tertentu dalam tempoh tertentu sebagai contoh mikro kredit berfungsi untuk melindungi isi rumah daripada kecairan aset untuk membayar pinjaman. Manakala takaful kesihatan pula menghalang kemungkinan daripada menggunakan pinjaman yang diluluskan untuk pembayaran bil hospital dan takaful harta seperti polisi kebakaran dapat menghalang isi rumah daripada risiko tidak dapat membayar semula pinjaman. Oleh itu, takaful mikro berfungsi sebagai mekanisme kemanusiaan, perniagaan atau kedua-dua sekali (Rebekah Yore dan Joanna Faure Walker, 2019). Demikian, takaful mikro boleh diringkaskan sebagai penawaran takaful berkost rendah yang ditawarkan kepada golongan miskin dan berpendapatan rendah dengan tujuan memberi perlindungan risiko yang sesuai kepada golongan ini.

Dalam Dasar Warga Tua Negara mendefinisikan “tua” adalah mereka yang berumur melebihi 60 tahun yang dianggap sebagai “tua”. Di negara maju dan membangun pula, mereka yang melebihi 65 tahun dianggap sebagai “tua” disebabkan oleh taraf ekonomi, pendidikan, taraf kesihatan yang lebih tinggi, perkhidmatan kesihatan yang lebih mantap, jangka hayat yang lebih panjang dan sebagainya jika dibandingkan dengan negara yang sedang membangun (Portal Rasmi Bahagian Pasca Perkhidmatan Jabatan Perkhidmatan Awam (JPA), 2018). Hal ini turut dinyatakan oleh Yung-Ping Chen bahawa di negara maju seperti Amerika Syarikat warga emas bermula pada umur 65 tahun (Yung-Ping Chen, 1987). Bagi takrifan mengikut kalendar umur terdapat konsep yang juga sering digunakan iaitu konsep “tua muda” (65-74), “tua-tua” (75-84) dan “paling tua-tua” (>85), konsep ini merupakan salah satu cara mudah untuk mengambil kira umur. Pada kebiasaannya, kumpulan warga emas “tua muda” tidak mempunyai banyak masalah (Portal Rasmi Bahagian Pasca Perkhidmatan JPA, 2018).

2.0 TAKAFUL MIKRO KEPADA WARGA EMAS MEMERLUKAN DANA TAMBAHAN DAN KERJASAMA DENGAN INSITUSI LAIN

Penawaran takaful mikro memerlukan dana sokongan daripada kerajaan, zakat, wakaf, tanggungjawab sosial korporat (CSR) dan lain-lain sumber yang sesuai seperti yang dapat dibincangkan di bawah ini.

2.1 Kerajaan

Penawaran takaful mikro memerlukan dana sokongan daripada kerajaan seperti yang dinyatakan oleh Ahmed MH, takaful mikro memerlukan subsidi daripada kerajaan (Ahmed MH, 2016). James Midgley (2012) pula menyatakan kerjasama yang berkesan dengan pihak kerajaan akan turut membantu menyediakan dana bantuan. Noor Ashikin Mohd Rom dan Zuriah Abdul Rahman (2012) menyatakan penawaran takaful mikro memerlukan sokongan daripada kerajaan untuk menyediakan polisi yang berkaitan dan memerlukan subsidi daripada kerajaan.

Dalam artikel lain oleh Noor Ashikin Mohd Rom dan Zuriah Abdul Rahman (2014) juga menyatakan penawaran takaful mikro boleh ditawarkan melalui penguatkuasaan polisi oleh kerajaan untuk membantu golongan miskin melalui takaful mikro dengan menyediakan dana sokongan daripada subsidi untuk dicarum secara bulanan kepada kumpulan ini. Kajian oleh Oscar Joseph Akotey, Kofi A. Osei dan Albert Gemegah (2011) menegaskan bahawa sokongan agensi kerajaan sangat diperlukan untuk meningkatkan permintaan insurans mikro di Ghana.

Selain itu, dalam kedua-dua penulis artikel oleh Haslifah Mohamad Hasim (2014 a) (2014 b) juga menyatakan takaful mikro memerlukan dana sokongan daripada kerajaan. Michal Matual et.al, insurans mikro dapat ditawarkan pada harga diskaun dengan menggunakan dana subsidi daripada kerajaan sebagai kaedah sementara untuk mempromosikan pembangunan pasaran (Michal Matual et.al, 2013). Oleh itu, sokongan yang diperlukan bukan hanya sokongan dana daripada kerajaan. Malah, sokongan yang diperlukan daripada kerajaan berbentuk penguatkuasaan, promosi, peraturan dan undang-undang berkaitan polisi takaful mikro supaya dapat meningkatkan penawaran takaful mikro.

2.2 Zakat dan Wakaf

Said Adekunle Mikail, Muhammad Ali Jinnah Ahmad, Salami Saheed Adekunle dalam kajiannya menyatakan integrasi yang berkesan bagi dana zakat dan wakaf dalam takaful mikro untuk menyokong kewangan akan memberi kesan positif kepada kehidupan ahli masyarakat yang kurang bernasib baik (Said Adekunle Mikail, Muhammad Ali Jinnah Ahmad, Salami Saheed Adekunle, 2017). Hal ini turut disokong oleh beberapa kajian lain iaitu Noor Ashikin Mohd Rom dan Zuriah Abdul Rahman (2012). Haslifah Mohamad Hasim (2014b) dalam *Microtakaful as an Islamic Financial Instrument, for Poverty Alleviation in Iraq*. Dalam artikel lain oleh Haslifah Mohamad Hasim (2014a) bertajuk *Developing a Conceptual Framework of Microtakaful as a Strategy towards Poverty Alleviation* turut menyatakan penawaran takaful mikro memerlukan dana daripada zakat dan wakaf. Sheila Nu Nu Htay, Nur

Shazwani Sadzali dan Hanudin Amin (2015) dalam kajiannya berkaitan takaful kesihatan mikro juga menyatakan dana tambahan daripada zakat dan wakaf.

Dalam artikel lain oleh Noor Ashikin Mohd Romdan Zuriah Abdul Rahman (2014) bertajuk *Asian-African Journal of Economic and Econometrics* menyebut dana zakat sebagai caruman bulanan dalam takaful mikro untuk golongan miskin. Hal ini, turut disokong oleh Ahmed MH (2016) dalam kajiannya sumber dana tambahan daripada zakat. Dalam kedua-dua kajian Haslifah Mohamad Hasim (2014a; 2014b) turut menyebut sumber zakat bukan hanya dalam negara. Bahkan turut melibatkan organisasi zakat antarabangsa sebagai sumber dalam takaful mikro. Wendy J. Werner, pula menyatakan takaful mikro memerlukan kewangan yang berdaya maju dengan mempunyai penyumbang untuk memberi sumbangan jangka panjang dengan menyediakan dana endowmen (2009).

2.3 Tanggungjawab Sosial Korporat (CSR)

Berdasarkan kajian Sheila Nu Nu Htay, Nur Shazwani Sadzali dan Hanudin Amin (2015), takaful kesihatan mikro boleh ditawarkan sebagai sebahagian daripada tanggungjawab sosial korporat (CSR) oleh syarikat takaful. Hal ini, turut disokong dalam penulisan Ahmed MH (2016) yang menyatakan penawaran takaful mikro memerlukan sumbangan daripada organisasi yang dianggap sebagai tanggungjawab sosial korporat oleh syarikat takaful.

2.4 Lain-lain sumber yang sesuai

Penawaran takaful mikro memerlukan dana sokongan daripada pelbagai sumber iaitu sumbangan boleh didapati daripada organisasi, individu dan pelanggan takaful sendiri. Ahmed MH (2016) menyatakan penawaran takaful mikro boleh didapati sumbangan daripada organisasi. James Midgley (2012) pula menyatakan penawaran takaful mikro memerlukan kerjasama yang berkesan dengan firma komersial, agensi pembangunan antarabangsa, organisasi bukan kerajaan yang besar dan penderma antarabangsa akan turut membantu menyediakan dana sokongan. Haslifah Mohamad Hasim (2014b) dalam *Microtakaful as an Islamic Financial Instrument, for Poverty Alleviation in Iraq* menyatakan dana sokongan daripada sumbangan dana perkongsian sumber-sumber yang sesuai diurus oleh syarikat takaful atau insituti takaful mikro.

Dalam artikel lain oleh Haslifah Mohamad Hasim (2014a) juga bertajuk *Developing a Conceptual Framework of Microtakaful as a Strategy towards Poverty Alleviation* menyatakan sumbangan daripada badan bukan kerajaan (NGO) dan sumbangan daripada agensi. Noor Ashikin Mohd Romdan Zuriah Abdul Rahman (2012) menyatakan dana boleh diperolehi insituti kebajikan yang berkaitan untuk membayar caruman kepada golongan ini. Christian Biener dan Martin Eling (2012), organisasi penderma boleh terlibat dalam pasaran insurans mikro, dana yang diperolehi mempunyai potensi besar untuk membantu skim takaful mikro mencapai skala operasi yang diperlukan. Hal ini, boleh dicapai dengan menyediakan modal dan pengetahuan kepada syarikat takaful mikro sendiri atau perantara dan insituti penyelidikan untuk memajukan pengetahuan perniagaan dan kapasiti.

Selain itu, sumbangan juga boleh didapati daripada individu seperti yang dinyatakan Wendy J. Werner (2009) penawaran takaful mikro memerlukan sumbangan daripada penderma. Yi (Kitty) Yao (2013), program insurans kesihatan mikro telah ditubuhkan dengan bantuan kewangan daripada penderma dengan harapan program-program ini akan berterusan dalam jangka masa panjang. Dana sokongan boleh didapati daripada pelanggan takaful seperti yang dinyatakan oleh Patty Jansen dalam kajiannya terdapat kesediaan dikalangan pelanggan untuk menyumbang kepada insurans mikro melalui sebuah syarikat insurans yang membantu menubuhkan projek insurans mikro di Belanda, hal ini menunjukkan peranan syarikat insurans boleh bertindak sebagai perantara antara penderma dan pelanggan (Patty Jansen, Tobias Gössling dan Toon Bullens, 2011). Marleen Dekker dan Annegien Wilms (2010), premium yang dibayar oleh pelanggan sektor tidak formal tidak mencukupi untuk menampung semua kos *microcare*. Oleh itu, bantuan premium yang dibayar oleh pelanggan dalam sektor formal digunakan menampung kos tersebut.

Berdasarkan kajian literatur penawaran takaful mikro kepada warga emas memerlukan dana tambahan daripada kerajaan, zakat, wakaf, tanggungjawab sosial korporat (CSR) dan lain-lain sumber dana supaya skim ini dapat ditawarkan secara meluas dan mampu dimiliki dengan pelbagai latar belakang taraf kewangan masyarakat. Ringkasan jurang penyelidikan dapat digambarkan seperti rajah berikut:

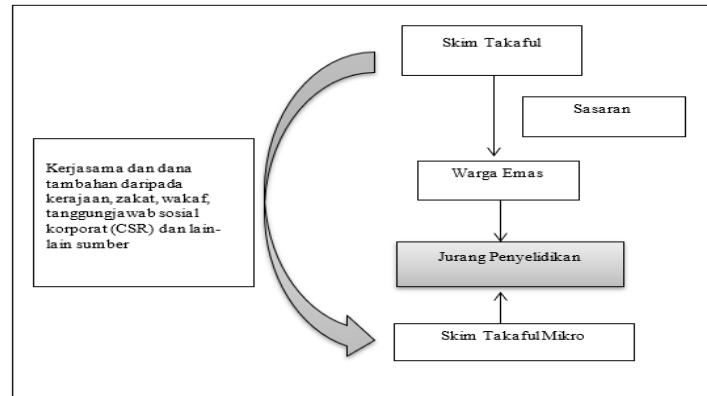
Rajah 1: Ringkasan Jurang Penyelidikan

Sumber: Asiah Kamal, Ahmad Azam Sulaiman@Mohamad, Mohammad Taqiuddin Mohamad (2017).

3.0 METODOLOGI

Metodologi kajian dilakukan secara kualitatif untuk mencapai tujuan kajian ini yang melibatkan temu bual dengan pengawal selia syarikat takaful, tiga syarikat takaful yang menawarkan takaful mikro dibawah inisiatif Perlindungan Tenang dan tiga penilai daripada wakil industri, pensihat Syariah bagi Wakaf Selangor Muamalat dan Zurich Takaful. Maklumat informan temu bual dapat disenaraikan seperti berikut:

3.1 Pengawal selia Syarikat Takaful

Bank Negara Malaysia (BNM) merupakan pengawal selia bagi industri insurans dan takaful di negara ini. Maklumat temu bual dengan pengawal selia adalah seperti maklumat berikut:

Jadual 1: Maklumat Temu Bual dengan Pengawal Selia

Institusi	Kod	Jawatan	Jabatan	Kaedah
Bank Negara Malaysia (BNM)	BNM	Penganalisis	Perbankan Islam dan Takaful	Individu secara bersemuka

Sumber: Olahan penyelidik berdasarkan kajian lapangan

Berdasarkan jadual, penyelidik telah menjalankan temu bual dengan penganalisis jabatan Perbankan Islam dan Takaful secara bersemuka dengan informan. Temu bual yang dijalankan bagi pengetahuan inisiatif yang diberikan oleh pengawal selia kepada syarikat takaful bagi penawaran takaful mikro kepada warga emas di negara ini.

3.2 Syarikat Takaful menawarkan Takaful Mikro di bawah Perlindungan Tenang

Kajian lapangan telah dijalankan dengan tiga syarikat yang menawarkan produk takaful mikro di bawah inisiatif Perlindungan Tenang (Informan BNM, 2019). Berikut merupakan senarai jawatan, jabatan dan kaedah temu bual yang telah dilakukan dengan ketiga-tiga syarikat takaful:

Jadual 2: Senarai Informan Produk Takaful Mikro Perlindungan Tenang

Syarikat	Produk	Kod	Jawatan	Jabatan	Kaedah
S1	A	Informan-A1	Penolong Pengurus	Pemasaran Produk	Individu secara bersemuka
S2	B	Informan-B1	Ketua	Pemasaran, Takaful Mikro dan CSR	Kumpulan secara bersemuka
		Informan-B2	Pengurus	Pemasaran, Takaful Mikro dan CSR (Produk)	
		Informan-B3	Pengurus	Pemasaran, Takaful Mikro dan CSR (CSR)	
S3	C	Informan-B4	Pengurus	Syariah	Individu secara bersemuka
		Informan-C1	Naib Presiden	Bancatakaful	Individu secara bersemuka
		Informan-C2	Naib Presiden	Syariah	Individu secara bersemuka

Sumber: Olahan penyelidik berdasarkan kajian lapangan

Berdasarkan jadual, temu bual telah dijalankan dengan informan daripada Syarikat takaful yang di kod sebagai S1, S2 dan S3 adalah secara bersemuka dengan kesemua informan. Temu bual yang dilakukan bagi mengetahui produk penawaran takaful mikro yang ditawarkan di bawah inisiatif Perlindungan Tenang seperti strategi penawaran, manfaat produk, sambutan masyarakat terhadap produk yang ditawarkan.

3.3 Penilai Model

Penilaian model melibatkan pengamal industri, ahli akademik yang terlibat sebagai penasihat syariah bagi penilaian model dana tambahan. Penilai daripada pengamal industri menggunakan kod P1, penilai daripada penasihat syariah Wakaf Selangor Muamalat menggunakan kod P2 dan penilai daripada penasihat syariah Zurich Takaful menggunakan kod P3.

Jadual 3: Senarai Penilai Model

Syarikat	Kod	Jawatan	Jabatan	Kaedah Penilaian
Syarikat S1/S6	P1	Naib Presiden	Syariah	Individu secara bersemuka
Penasihat Syariah	Kod	Ahli Akademik Bidang	Jabatan	Kaedah Penilaian
Wakaf Muamalat	P2	Wakaf	Syariah dan Ekonomi, Akademi Pengajian Islam, Universiti Malaya	Individu secara bersemuka
Zurich Takaful	P3	Wakaf dan Zakat	Jabatan Fiqh dan Usul Akademi Pengajian Islam, Universiti Malaya	Individu secara bersemuka

Sumber: Olahan penyelidik berdasarkan kajian lapangan

Berdasarkan jadual, penyelidik telah menjalankan temu bual dengan penilaian model secara bersemuka dengan ketiga-tiga penilai. Penilaian model dinilai berdasarkan model-model yang telah dibina oleh penyelidik berdasarkan analisis kajian lepas dan kajian lapangan yang telah dilakukan. Model-model nilai berdasarkan penggunaan dana wakaf dan endowmen; CSR Wakaf, zakat dan pelbagai sumber dana yang dinilai satu persatu terhadap penggunaan dana tersebut oleh penilai.

4.0 PENAWARAN TAKAFUL MIKRO DI BAWAH INISIATIF PERLINDUNGAN TENANG

Bank Negara Malaysia (BNM) dengan kerjasama syarikat takaful telah melakukan inisiatif untuk menawarkan takaful mikro di bawah Perlindungan Tenang. Berikut merupakan kelebihan penawaran produk takaful mikro di bawah inisiatif ini (Malaysian Takaful Association (MTA), 2019).

- i. Berpatutan (*affordable*): sumbangan yang rendah.
- ii. Ringkas (*simple*): sijil penyertaan takaful ringkas dan mudah untuk difahami.
- iii. Mudah untuk menyertai (*easy to purchase/participate*): penyertaan adalah dalam talian secara *online*, syarikat takaful atau ejen dan juga boleh didapati di cawangan bank terpilih dan telefon mudah alih.
- iv. Proses tuntutan yang mudah (*easy claims process*): tuntutan dengan dokumentasi lengkap akan dibayar dalam tempoh lima hari bekerja.

Berikut merupakan kelebihan penawaran produk takaful mikro di bawah Perlindungan Tenang oleh tiga-tiga syarikat takaful yang telah mengambil bahagian dalam inisiatif ini (Informan BNM, 2019).

4.1 Produk A

Produk A ditawarkan oleh syarikat S1 adalah pelan takaful keluarga bertempoh 1 tahun yang menyediakan perlindungan kematian. Pelan ini terbuka kepada individu berumur 16 hingga 55 tahun (laman rasmi syarikat S1) dan boleh disertai dalam talian secara *online* (Informan A1, 2019). Caruman yang perlu dibayar adalah sebanyak RM 40 secara tahunan bagi amaun perlindungan minimum RM10,000 (laman rasmi syarikat S1). Pilihan amaun perlindungan bermula daripada jumlah minimum sebanyak RM10,000 sehingga jumlah maksimum sebanyak RM30,000 (laman rasmi syarikat S1). Berikut merupakan ringkasan maklumat produk A.

Jadual 4: Ringkasan Maklumat A

No.	Butiran	Penerangan
1	Had umur penyertaan	Umur 16-55 tahun
2	Had umur perlindungan	Sehingga umur 55 tahun
3	Manfaat	Kematian
4	Anggaran jumlah caruman minimum	RM40 setahun bagi amaun perlindungan minimum RM10,000
5	Jumlah Perlindungan	RM 10,000/RM 15,000/RM 20,000/ RM 25,000/RM 30,000 *Tertakluk kepada maksimum RM30,000 setiap hayat
6	Saluran Penawaran	Talian secara <i>online</i>

Sumber: Temu bual dan laman sesawang

4.2 Produk B

Produk B ditawarkan oleh syarikat S2 adalah pelan takaful keluarga bertempoh yang mampu dimiliki dan boleh diperbaharui setiap tahun. Produk B boleh diperbaharui sehingga umur 70 tahun iaitu umur pada hari lahir akan datang. Penyertaan terbuka kepada warganegara Malaysia atau penduduk tetap yang sedang menetap di Malaysia berumur dari 19 hingga 60 tahun pada hari lahir akan datang (laman rasmi syarikat S2, 2019). Produk B boleh didapati dalam talian secara *online* (Informan B1, 2019). Perlindungan yang ditawarkan adalah kematian atau hilang upaya menyeluruh dan kekal (TPD) (laman rasmi syarikat S2).

Anggaran amaun sumbangan sebanyak RM50 setahun (laman rasmi MTA, 2019), amaun sumbangan sebenar adalah tertakluk kepada umur, status kesihatan, amaun perlindungan, pekerjaan dan jantina (laman rasmi syarikat S2, 2019). Pembayaran sumbangan sehingga tamat tempoh sijil dan amaun sumbangan akan bertukar apabila umur bertambah (laman rasmi syarikat S2, 2019). Jumlah perlindungan minimum RM20,000 sehingga 500,000 (laman rasmi syarikat S2, 2019). Berikut merupakan ringkasan maklumat produk B.

Jadual 5: Ringkasan Maklumat Produk B

No.	Butiran	Penerangan
1	Had umur penyertaan	Umur 19-60 tahun
2	Had umur perlindungan	Sehingga umur 70 tahun
3	Manfaat	Kematian dan hilang upaya menyeluruh dan kekal
4	Anggaran amaun sumbangan	RM50 setahun *Amaun sumbangan sebenar adalah tertakluk kepada umur, status kesihatan, amaun perlindungan, pekerjaan dan jantina **Pembayaran sumbangan sehingga tamat tempoh sijil dan amaun sumbangan akan bertukar apabila umur bertambah
5	Jumlah Perlindungan	RM20,000 sehingga RM500,000 *Berdasarkan temu bual, produk ini menepati Perlindungan Tenang. Namun, bukan hanya golongan B40 yang boleh sertai kerana jumlah perlindungan bergantung kepada amaun peserta yang ingin dilindungi
6	Saluran Penawaran	Talian secara <i>online</i>

Sumber: Temu bual dan laman sesawang

4.3 Produk C

Produk C ditawarkan oleh syarikat S3 merupakan pelan bertempoh dan perlu diperbaharui setiap tahun (Risalah produk C, 2017). Had umur penyertaan adalah pada umur 18-64 tahun (Risalah produk C, 2017). Manfaat perlindungan yang ditawarkan ialah manfaat kematian akibat penyakit, kematian akibat kemalangan, hilang keupayaan kekal menyeluruh, badal haji, wakaf dan perbelanjaan kematian (Risalah produk C, 2017). Kedah penyertaan terbuka kepada individu dan kumpulan (Risalah produk C, 2017). Jumlah caruman minimum bagi pelan individu RM 75 dan jumlah caruman minimum bagi pelan kelompok RM40 (Risalah produk C, 2017). Penyertaan bagi produk ini adalah di cawangan Agro Bank di seluruh Malaysia (Informan C, 2019). Berikut merupakan ringkasan maklumat produk C.

Jadual 6: Ringkasan Maklumat Produk C

No.	Butiran	Penerangan
1	Had umur penyertaan	Umur 18-64 tahun
2	Had umur perlindungan	Sehingga umur 64 tahun
3	Manfaat Perlindungan	Manfaat kematian akibat penyakit, kematian akibat kemalangan, hilang keupayaan menyeluruh dan kekal (TPD), badal haji, wakaf dan perbelanjaan kematian
4	Kaedah Penyertaan	Individu dan kumpulan
5	Jumlah caruman	Pelan terbuka secara individu Pelan 1 RM75, Pelan 2 RM135 dan Pelan 3 RM195 Pelan kelompok secara kumpulan Pelan A RM40, Pelan B RM60
6	Saluran Penawaran	Cawangan Agro Bank seluruh Malaysia

Sumber: Temu bual Informan C1 dan laman rasmi Agro Bank, (2019)

Jumlah perlindungan mengikut manfaat dan sumbangan bagi pelan terbuka kepada individu dapat dilihat berdasarkan jadual berikut:

Jadual 7: Pelan Perlindungan Terbuka kepada Individu

Manfaat/Pelan	Pelan 1 (RM)	Pelan 2 (RM)	Pelan 3 (RM)
Kematian/hilang keupayaan kekal menyeluruh akibat penyakit	13,000	26,000	40,000
Kematian/hilang keupayaan kekal menyeluruh akibat kemalangan	26,000	52,000	80,000
Badal haji	3,500	3,500	3,500
Wakaf	500	500	500
Perbelanjaan kematian serta merta	1,000	1,000	1,000
Sumbangan takaful setahun	75	135	195

Sumber: Maklumat berdasarkan risalah yang diperolehi semasa temu bual C1, (2019) dan laman rasmi Agro Bank, (2019).

Jumlah perlindungan mengikut manfaat bagi pelan berkelompok kepada kumpulan dapat dilihat berdasarkan jadual berikut:

Jadual 8: Pelan Perlindungan berkelompok kepada kumpulan

Manfaat/Pelan	Pelan 1 (RM)	Pelan 2 (RM)
Kematian/Hilang keupayaan kekal menyeluruh akibat penyakit	5,000	10,000
Kematian/Hilang keupayaan kekal menyeluruh akibat kemalangan	10,000	15,000
Badal haji	3,500	3,500
Wakaf	500	500
Perbelanjaan kematian serta merta	1,000	1,000
Sumbangan takaful setahun	40	60

Sumber: Maklumat berdasarkan risalah yang diperolehi semasa temu bual C1, (2019) dan laman rasmi Agro Bank, (2019).

4.4 Ringkasan Maklumat bagi Ketiga-tiga Takaful Mikro di bawah Inisiatif Perlindungan Tenang

Jadual 9: Takaful Mikro di bawah Inisiatif Perlindungan Tenang

Syarikat Takaful	S1	S2	S3
Nama Produk	A	B	C
Saluran Penyertaan	Dalam talian secara <i>online</i>	Dalam talian secara <i>online</i>	Cawangan Agro Bank
Umur Kemasukan	16-55 tahun	19-60 tahun	18-64 tahun (bagi yang berumur 60 tahun ke atas hanya layak 1 pelan sahaja)
Had Umur Perlindungan	Sehingga umur 55 tahun	Sehingga umur 70 tahun	Sehingga umur 64 tahun
Jumlah Perlindungan	RM10,000/ RM15,000/ RM20,000/ RM25,000/ RM30,000	RM20,000/ RM30,000	RM13,000 (Pelan 1)/ RM26,000 (Pelan 2)/ RM40,000 (Pelan 3)
Sumbangan	Serendah RM39 setahun (tertakluk kepada umur/ jantung)	Serendah RM50 setahun (tertakluk kepada umur, jantung, status kesihatan dan pekerjaan)	RM75 (Pelan 1)/ RM135 (Pelan 2)/ RM195 (Pelan 3) Tahunan

Sumber: Laman rasmi MTA, (2019).

Berdasarkan penawaran takaful mikro di bawah inisiatif Perlindungan Tenang yang terdapat dipasaran dapat dikenalpasti bahawa penawaran takaful mikro yang belum ditawarkan secara inklusif kepada warga emas. Bagi produk A, umur kemasukan 16-55 tahun dan had umur perlindungan sehingga 55 tahun. Produk B pula, umur kemasukan 19-60 tahun dan had umur perlindungan sehingga 70 tahun. Manakala produk C umur kemasukan 18-64 tahun dan umur perlindungan sehingga 64 tahun. Berdasarkan penawaran takaful mikro di bawah inisiatif Perlindungan Tenang hanya produk B dan C boleh disertai oleh warga emas. Bagi produk B menawarkan had umur perlindungan sehingga 70 tahun. Manakala produk C menawarkan had umur perlindungan sehingga 64 tahun. Walaupun produk B dan C boleh disertai oleh warga emas dari sudut umur kemasukan dan had umur perlindungan. Namun, produk ini masih terikat dengan syarat-syarat yang ditetapkan. Oleh itu, produk takaful mikro yang ditawarkan belum inklusif untuk disertai oleh warga emas. Demikian, berdasarkan kajian lepas dan penawaran

takaful mikro semasa yang terdapat dipasaran penyelidik merasakan perlu mempunyai model-model khusus sebagai dana tambahan untuk penawaran takaful mikro secara umum dan khususnya untuk penawaran kepada warga emas.

5.0 MODEL DANA TAMBAHAN TAKAFUL MIKRO KEPADA WARGA EMAS

Model takaful mikro yang akan di bincangkan menggunakan dana tambahan daripada wakaf, zakat, CSR dan lain-lain sumber. Model yang dicadangkan merupakan model adaptasi daripada model sedia ada yang terdapat pasaran. Walaupun terdapat sebahagian model asal bukan bertujuan untuk penawaran takaful mikro.

5.1 Model Wakaf dan Endowmen

Rajah 2: Model Wakaf dan Endowmen berdasarkan Syarikat S1

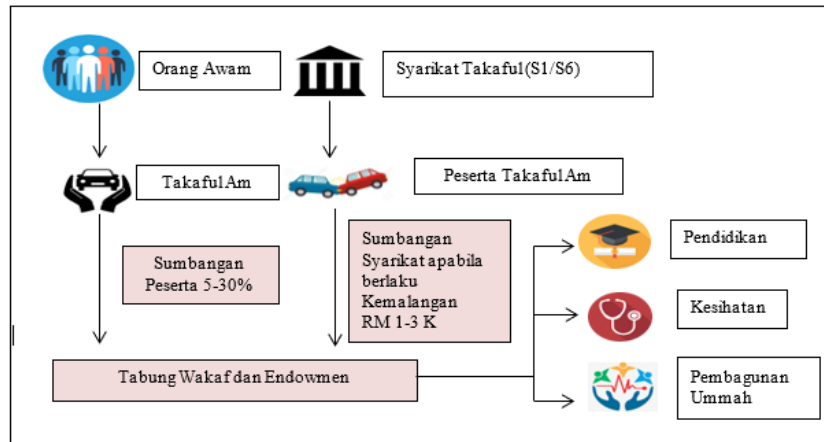

Sumber: Laman sesawang syarikat S1 dan disemak oleh C2.

Rajah 2 a): Model Adaptasi Syarikat S1 Wakaf dan Endowmen

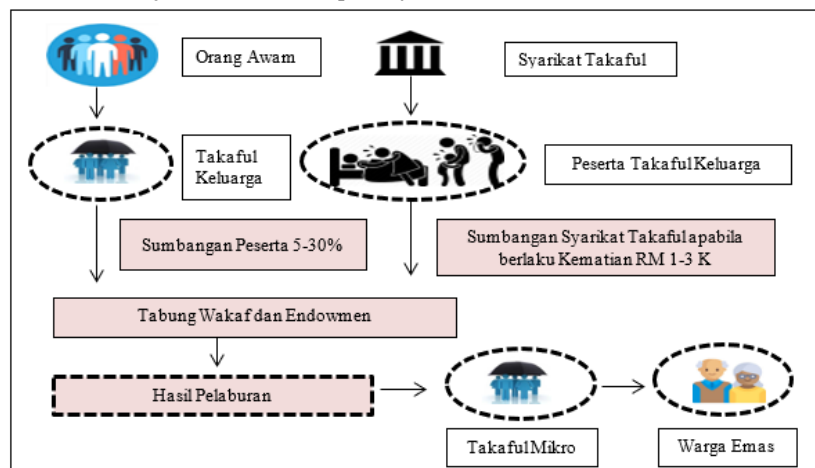

Sumber: Analisis penyelidik dan model ini telah dinilai oleh P1, P2 dan P3

Berdasarkan pelaksanaan di syarikat S1 waqf dan endowmen telah diperkenalkan kepada semua peserta sijil produk individu atau perkhidmatan takaful am bermula 1 April 2019 (laman rasmi syarikat S3, 2019). Penawaran takaful mikro diadaptasi berdasarkan penawaran bagi produk takaful am yang dapat digambarkan seperti Rajah 2. Demikian, model yang sama diadaptasi berdasarkan pelaksanaan di syarikat S1 menggunakan dana wakaf dan endowmen sebagai dana tambahan. Kemudian, syarikat takaful boleh menawarkan takaful mikro kepada warga emas dengan dana tambahan yang di cadangkan. Model ini telah dinilai oleh P1, P2 dan P3 bagi tujuan pelaksanaan dana tambahan bagi penawaran takaful mikro kepada warga emas seperti penilaian berikut:

Berdasarkan penilaian model yang telah dilakukan dengan P1, tabung sedia ada yang terdapat di syarikat S1 disalurkan kepada tabung wakaf dan P1 bersetuju serta turut mendapat idea berdasarkan perbincangan dilakukan dengan penyelidik bahawa terdapat keperluan pada masa akan datang syarikat S1 mempunyai tabung wakaf sendiri supaya dapat disalurkan sendiri dana tersebut seperti yang dilakukan Bank Muamalat yang mempunyai tabung wakaf sendiri yang diurus oleh Wakaf Selangor Muamalat (Penilai P1, 2019).

Berdasarkan penilaian oleh P2 dapat dijelaskan bahawa penawaran takaful mikro berdasarkan model adaptasi syarikat S1 wakaf dan endowmen sudah baik dan bagus cadangan ini. Namun, model ini akan menghadapi masalah saiz dana yang kecil. Oleh itu, penilai P2 mencadangkan dana tambahan dapat digabungkan secara konsertium, kerajaan negeri dan kedua-duanya sekali (Penilai P2, 2019).

Berdasarkan penilaian model yang telah dilakukan oleh P2 dapat digambarkan seperti rajah berikut:

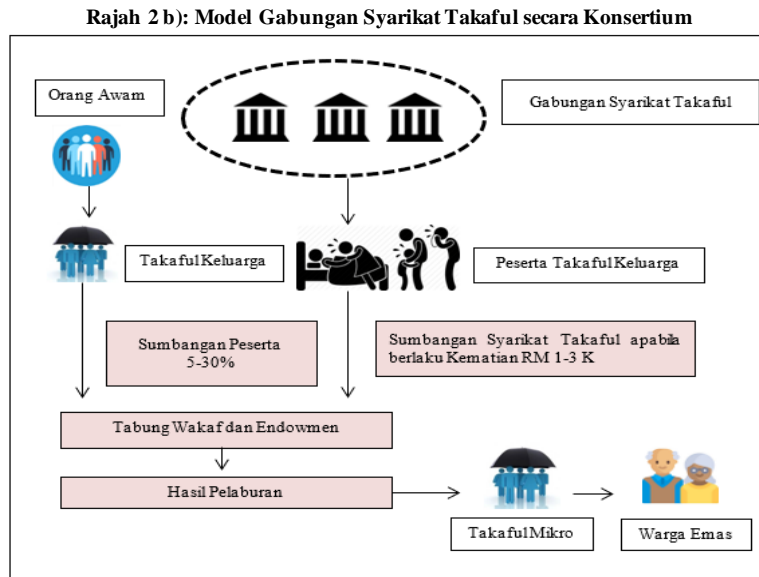

Sumber: Model ini dicadangkan sebagai model tambahan daripada rajah 2 a) semasa penilaian dilakukan oleh P2 serta turut dinilai oleh P3.

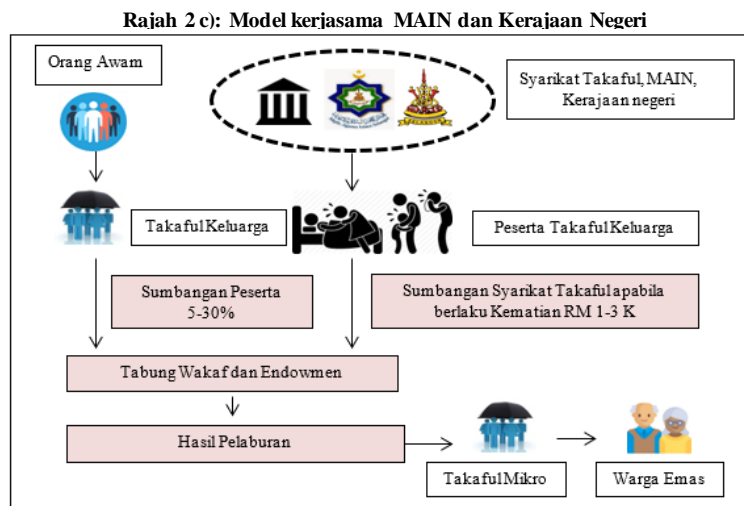

Sumber: Model ini dicadangkan sebagai model tambahan daripada rajah 2 a) semasa penilaian dilakukan oleh P2 serta turut dinilai oleh P3.

Rajah 2 d): Model Gabungan Syarikat Takaful, MAIN dan Kerajaan Negeri

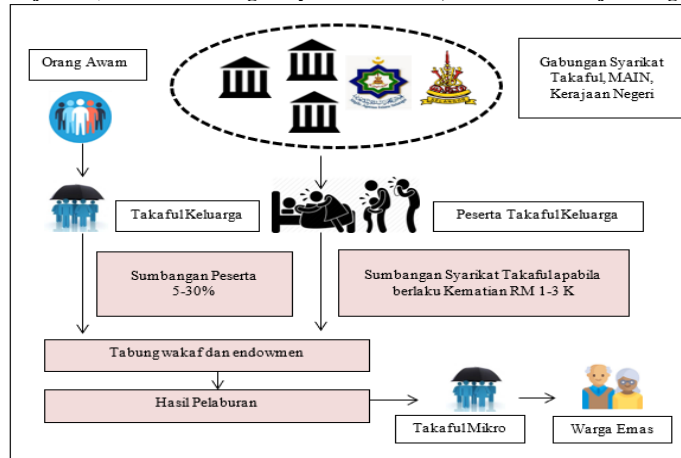

Sumber: Model ini dicadang sebagai model tambahan daripada rajah 2 a) semasa penilaian dilakukan oleh P2 serta turut dinilai oleh P3.

Berdasarkan penilaian model P2 juga mencadangkan dana wakaf dilakukan pelaburan iaitu antara pelaburan yang dilakukan adalah dalam *fix deposit* atau sebarang pelaburan yang selamat (Penilai P2, 2019). Cadangan pelaburan yang dicadangkan oleh P2 dengan model pelaburan berdasarkan tulisan oleh Siti Mashitoh Mahmood, Asmak Ab Rahman dan Azizi Che Seman, (2018). Demikian, model penawaran takaful mikro menggunakan dana wakaf dengan dana tambahan daripada hasil pelaburan wakaf dapat digambarkan seperti rajah berikut:

Rajah 2 e): Model Pelaburan Dana Wakaf

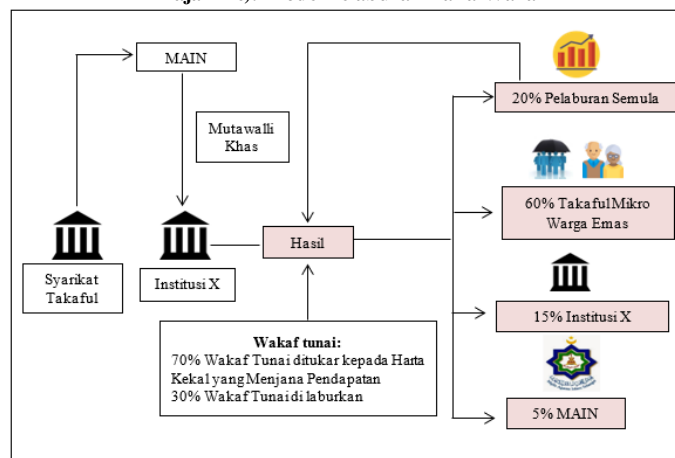

Sumber: Model ini dicadang sebagai model tambahan daripada rajah 2 a) semasa penilaian dilakukan oleh P2 dengan rujukan dan o lahan daripada model dalam artikel oleh Siti Mashitoh Mahmood et. al, (2018) serta turut dinilai oleh P3.

Berdasarkan penilaian model oleh P3, menyatakan model yang dicadangan tiada sebarang masalah atau isu yang berkaitan syarak. Bagi wakaf tunai terdapat dua (2) cara dalam feqah yang pertama adalah Mazhab Hanafi iaitu wang tunai boleh dilaburkan secara mudharabah. Jadi, wang tadi dimasukkan dalam pelaburan mudharabah. Kemudian, jumlah asal itu diwakafkan. Manakala keuntungan diberi kepada penerima manfaat (*beneficiary*). Kedua, wakaf tunai mengikut Mazhab Maliki boleh di buat tabung wakaf. Daripada tabung wakaf tersebut digunakan untuk beri pinjaman. Kemudian, dibayar balik. Jadi, tabung tersebut kekal kerana wang tersebut dibayar balik oleh peminjam. Oleh itu, terdapat dua (2) model yang ada bagi wakaf tunai dalam feqah. Bagi Mazhab Syafie dan Hanbali tidak terima langsung bagi wakaf tunai ini. Berasaskan dua model yang boleh dikembangkan dalam bentuk wakaf korporat ini iaitu daripada mazhab Hanafi dan Maliki. Demikian, model yang dicadangkan perlu di pastikan dana wakaf dalam tabung digunakan untuk menjana pendapatan tanpa menggunakan dana asas daripada tabung tersebut supaya dana dapat di kekal nilai asasnya (Penilai P3, 2019).

Analisis Penilaian Model

Berdasarkan penilaian model cadangan wakaf dan endowmen oleh ketiga-tiga penilai. Model ini mempunyai potensi untuk ditawarkan takaful mikro kepada warga emas dengan dana tambahan daripada wakaf dan endowmen. Penilaian P1 menyatakan model ini mempunyai potensi untuk ditawarkan berbentuk takaful mikro kepada warga emas. Tambahan, model ini telah pun dilaksanakan diperingkat penawaran takaful am di syarikat S1. Penilaian P2

pula menekankan aspek saiz dana dan perlu ditambah dengan sumber dana daripada lain-lain sumber seperti gabungan dana daripada syarikat-syarikat takaful, kerajaan negeri, MAIN dan pelaburan wakaf. Penilai P3 pula menyatakan model cadangan berasaskan wakaf dan endowmen perlu kekal dalam jumlah asal dan hasil pelaburan digunakan untuk dimanfaatkan untuk penawaran takaful mikro kepada warga emas. Oleh itu, model dana tambahan menggunakan dana wakaf dan endowmen boleh dilaksanakan kerana tabung wakaf dan endowmen telah pun dilakukan di syarikat S1.

5.2 Model CSR wakaf

Model cadangan berdasarkan CSR wakaf dicadangkan berdasarkan pelaksanaan Wakaf An-Nur sebagai syarikat yang menguruskan CSR JCORP yang telah diwakafkan untuk melaksanakan CSR Islam. Model ini dapat digambarkan seperti rajah berikut:

Rajah 3: Model CSR Wakaf berdasarkan JCORP

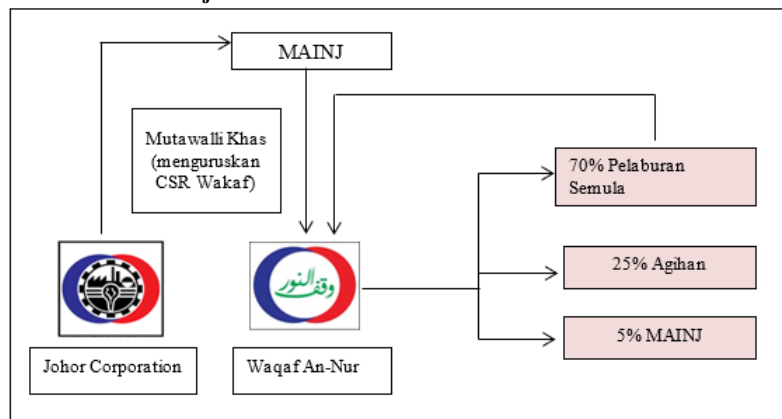

Sumber: Nooh Gadot, (2014).

Rajah 3 a): Model adaptasi CSR Wakaf

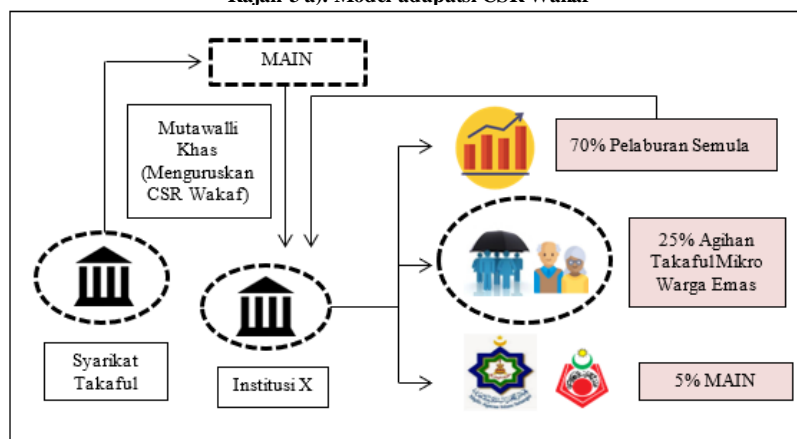

Sumber: Model ini telah dinilai oleh P1, P2 dan P3

Model adaptasi menggunakan CSR wakaf untuk penawaran takaful mikro boleh dilaksanakan oleh syarikat takaful dengan melantik institusi X untuk menguruskan CSR berbentuk wakaf seperti model pelaksanaan oleh JCORP yang telah melantik WANCorp untuk menguruskan CSR yang telah diwakafkan. Model ini telah dinilai oleh P1, P2 dan P3 seperti berikut:

Berdasarkan penilaian model CSR wakaf oleh P1 memaklumkan bahawa P1 mewakili syarikat S1 baru sahaja menerima taklimat daripada WanCorp berkaitan Wakaf CSR dan menyatakan model CSR wakaf seperti yang telah dilakukan di WanCorp masih melihat kesesuaian untuk melakukan kaedah ini. Namun, berdasarkan pelaksanaan di WanCorp pengurusan wakaf lebih cekap apabila mempunyai entiti khusus yang memberi fokus kepada pengurusan wakaf (Penilai P1, 2019).

Berdasarkan penilaian model oleh P2 menyatakan penggunaan CSR wakaf untuk penawaran takaful mikro tiada sebarang masalah untuk menggunakan dana ini. Namun, saiz dana perlu dipastikan mencukupi dan stabil. (Penilai P2, 2019).

Berdasarkan penilaian model oleh P3, penawaran takaful mikro menggunakan dana daripada CSR wakaf tiada sebarang masalah, penggunaan dana daripada CSR wakaf seperti yang telah dilaksanakan oleh WanCorp di Johor oleh Tan Sri Ali Hashim sebagai wakaf korporat senang untuk mendapat keuntungan dan merupakan model yang terkehadapan yang boleh dicontohi berbanding di negeri lain (Penilai P3, 2019).

Analisis Penilaian Model

Berdasarkan penilaian model oleh P1 berdasarkan model adaptasi CSR wakaf seperti yang dilakukan oleh JCOR dengan melantik WanCorp sebagai pengurus CSR wakaf membolehkan CSR dapat dilakukan secara lebih khusus kerana tanggungjawab pengagihan diletakkan di bawah institusi khusus yang akan menyebabkan kerja hakiki jabatan tidak terganggu. Oleh itu, terdapat keperluan untuk melantik institusi X bagi tujuan memberi tumpuan kepada pengurusan CSR. Manakala bagi P2 dan P3 sangat menyokong cadangan pelaksanaan bagi model adaptasi CSR wakaf ini kerana dapat mengembangkan saiz dana wakaf dan mengekalkan dana wakaf.

5.3 Model Zakat

Model cadangan berasaskan zakat menggunakan peratus agihan wakalah untuk penawaran takaful mikro. Model ini dapat digambarkan seperti rajah berikut:

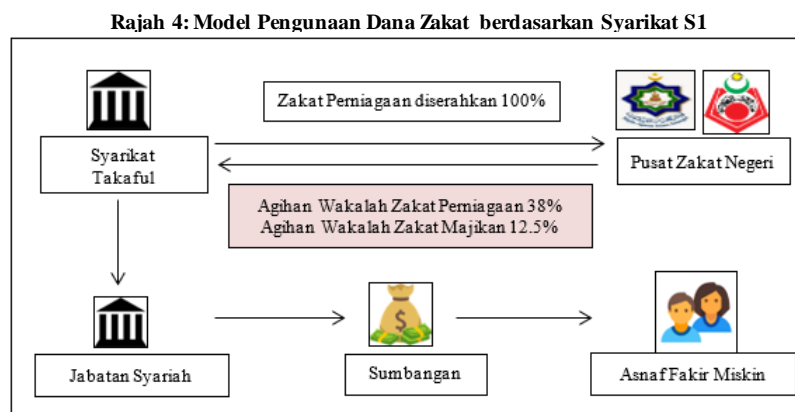

Sumber: Temu bual dan telah disemak oleh C2.

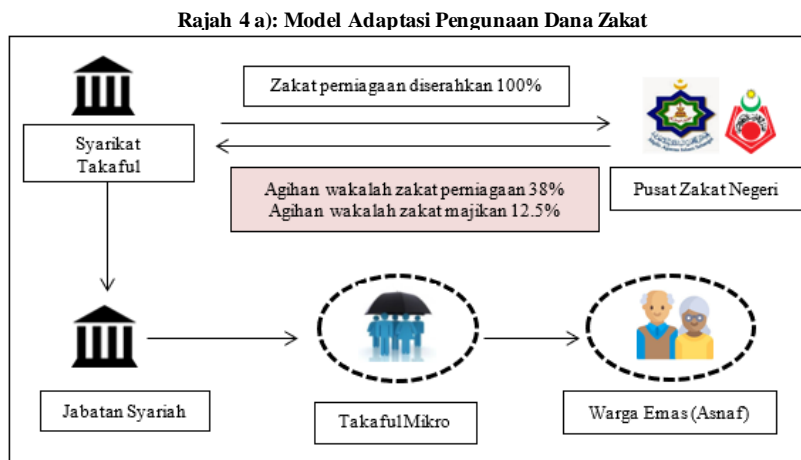

Sumber: Model ini telah disemak oleh P1, P3

Berdasarkan model cadangan zakat di atas, model ini menggunakan zakat bahagian agihan wakalah perniagaan dan bahagian agihan wakalah majikan berbentuk sumbangan kepada asnaf fakir miskin atau (B40) dan perancangan masa akan datang dalam memberi agihan zakat kepada fakir miskin atau (B40) berbentuk perniagaan (*asnaf entrepreneurship programe*) sebagai ejen takaful, perlindungan takaful dan pendidikan takaful. Hal ini, kerana pihak BNM telah memberi garis panduan untuk melakukan *Value Base Intermediation (VBI)* berdasarkan tiga (3) elemen iaitu ekonomi (*profit*), komuniti (*community*), alam sekitar. Bagi syarikat takaful, hanya perlu fokus kepada aspek ekonomi dan komuniti (Informan C2, 2019). Selaras dengan kajian ini, penyelidik mencadangkan model adaptasi penggunaan dana zakat dalam penawaran takaful mikro kepada warga emas pada masa hadapan dan di nilai oleh P1 dan P3.

Berdasarkan penilaian model yang telah dilakukan oleh P1, penawaran takaful mikro kepada warga emas menggunakan dana zakat menepati inisiatif BNM di bawah VBI, VBI adalah *“the expected outcomes of Shariah through practices and services”*. Bagi maksud istilah *“outcome”* dari sudut syariah dengan kata lain ialah Maqasid Syariah yang lima. Jadi, produk, amalan dan perkhidmatan yang ditawarkan kepada orang ramai mesti memenuhi *“outcome”* seperti yang dinyatakan. Di bawah VBI juga terdapat 3P iaitu *People, Planet, Profit*. P yang pertama *People* bermakna masyarakat dan komuniti. P yang kedua *Planet* bermaksud menjaga persekitaran dan P yang ketiga bermaksud *Profit* adalah ekonomi. Secara mudah untuk difahami *profit* sini adalah bermaksud *beyond profit* iaitu bukan soal *dollar and cents* semata-mata. Bagi kajian warga emas boleh dikaitkan dengan VBI yang P untuk *People* seperti yang diterangkan sebentar tadi. Bagi VBI, syarikat takaful boleh menggunakan elemen ekonomi dan komuniti. Oleh itu, penawaran takaful mikro kepada warga emas menepati inisiatif BNM yang telah diberikan kepada syarikat takaful (Penilai P1, 2019).

Meskipun, model tersebut berbeza dengan perancangan syarikat takaful S1 pada masa terdekat. Namun begitu, dalam perbincangan bersama P1 menyokong pelaksanaan ini dan turut memberi cadangan untuk melakukan penawaran tersebut dengan mencadangkan kepada MAIN memberi kebenaran kepada syarikat takaful membuat pengagihan sendiri secara keseluruhan dan membuat pemantauan berdasarkan cadangan agihan zakat oleh syarikat takaful serta syarikat takaful perlu menghantar laporan kepada bahagian zakat negeri (Penilai P1, 2019). Penilai P1 juga turut cadangkan pelaksanaan model ini perlu mendapatkan kebenaran daripada MAIN dengan mempertimbangkan memberi kebenaran kepada syarikat takaful membuat pengagihan sendiri dana zakat dengan pemantauan supaya agihan dapat dilakukan dengan betul seperti permohonan berbentuk proposal untuk cadangan agihan dan laporan kepada MAIN. Hal ini, tidak mustahil kerana pihak MAIN telah pun memberi agihan wakalah kepada pihak syarikat takaful untuk menguruskan pengagihan sendiri sebanyak 38% daripada zakat wakalah korporat dan 12.5% daripada zakat wakalah majikan untuk diurus sendiri oleh syarikat takaful (Penilai P1, 2019). Berdasarkan penilaian yang diberikan P1, penyelidik menggambarkan proses permohonan agihan zakat oleh syarikat takaful secara sendiri seperti berikut:

Rajah 5: Proses Permohonan agihan zakat oleh syarikat korporat secara sendiri

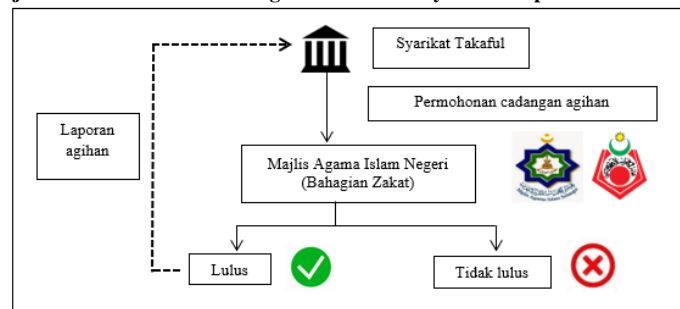

Sumber: Gambaran penyelidik terhadap proses permohonan agihan zakat oleh syarikat korporat secara sendiri dan dinilai oleh P3

Berdasarkan penilaian model oleh P3 menyatakan model zakat dapat dilakukan menggunakan dana zakat dan cadangan untuk mendapatkan kebenaran daripada MAIN untuk syarikat takaful menguruskan agihan dana zakat sendiri juga boleh dilakukan kerana sekarang ini MAIN sendiri telah memberi kebenaran kepada syarikat korporat sebanyak 38% untuk diurus sendiri dan untuk memohon agar agihan zakat dapat diurus sendiri oleh syarikat korporat 100% tiada isu dari sudut syarikat hanya perubahan dari sudut peratus itu sahaja. Dalam masa yang sama, syarikat takaful perlu memastikan penerima zakat dikalangan warga emas merupakan warga emas yang terdiri daripada asnaf zakat kerana tidak semua warga emas tersenarai dalam kategori asnaf zakat (Penilai P3, 2019).

Analisis Penilaian Model

Berdasarkan penilaian P1, pihak syarikat takaful mempunyai perancangan sendiri untuk agihan dana zakat yang diperolehi daripada MAIN. Namun begitu, berdasarkan penilaian model yang telah dilakukan dengan P1 turut bersetuju dengan menyatakan terdapat potensi pelaksanaan bagi model adaptasi penggunaan dana zakat untuk penawaran takaful mikro kepada warga emas. Berdasarkan penilaian oleh P3 pula, menyatakan tiada sebarang masalah bagi pengagihan zakat oleh syarikat takaful secara sendiri. Namun, terdapat masalah undang-undang yang ditetapkan oleh pemimpin yang perlu dihadapi oleh syarikat takaful bagi pengagihan sendiri dana zakat oleh syarikat takaful. Oleh itu, syarikat takaful perlu mendapat kebenaran daripada MAIN untuk mendapat menguruskan dana zakat sepenuhnya atau sekurang-kurangnya mendapat peratusan agihan wakalah yang lebih tinggi untuk penawaran takaful mikro kepada warga emas. Hal ini tidak mustahil untuk dilakukan kerana MAIN bahagian zakat telah pun memberi peratusan tertentu kepada syarikat takaful untuk membuat pengagihan sendiri. Selain itu, bagi pengagihan dana zakat kepada warga emas perlu dikenalpasti bahawa warga emas tersebut tergolong dikalangan asnaf kerana tidak semua warga emas termasuk dalam kategori asnaf. Demikian, bagi tujuan tersebut pihak syarikat takaful perlu menyediakan laporan bagi memastikan agihan zakat yang dilakukan adalah dikalangan warga emas yang terdiri

daripada senarai kumpulan asnaf yang lapan (8).

5.4 Model Dana daripada Pelbagai Sumber

Model dana daripada pelbagai sumber melibatkan sumber zakat, wakaf, sedekah dan CSR yang diperoleh daripada syarikat takaful, kakitangan dan pelanggan daripada syarikat seperti yang telah dilaksanakan oleh syarikat S3. Oleh itu, perbincangan model ini merupakan model adaptasi takaful mikro daripada syarikat S3 menggunakan dana daripada pelbagai sumber yang dapat digambarkan seperti rajah berikut:

Rajah 6: Model Takaful Mikro berdasarkan Syarikat S3

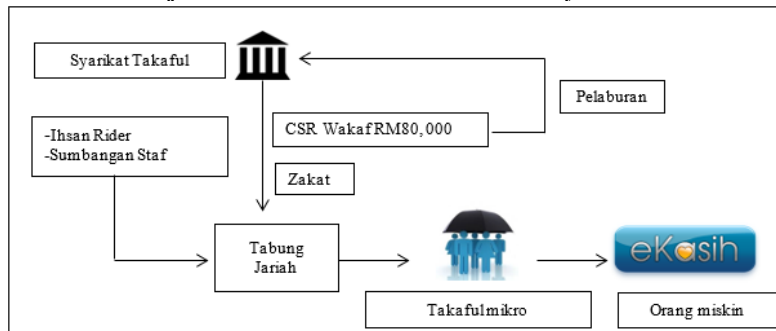

Sumber: Temu bual dengan jabatan pemasaran, takaful mikro dan CSR iaitu B1, B2 dan B3 serta pengesahan daripada Jabatan Syariah daripada syarikat S3.

Rajah 6 a): Model Adaptasi Takaful mikro

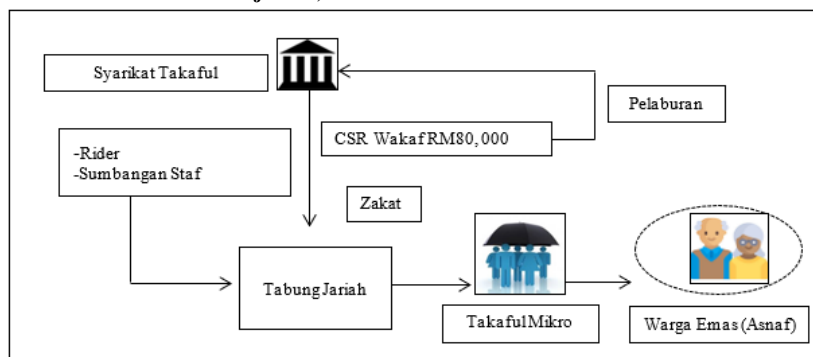

Sumber: Model ini dinilai oleh P1 dan P3

Berdasarkan model diatas, syarikat S3 telah menawarkan takaful mikro secara percuma (Informan B3, 2019). Penawaran produk ini merupakan salah satu inisiatif daripada syarikat S3 yang bertujuan untuk membantu isi rumah berpendapatan rendah mendapat akses kepada produk takaful (Informan B2, 2019). Program ini menyediakan perlindungan hayat bertempoh setahun bagi ketua isi rumah di bawah garis kemiskinan B40 (Laman rasmi syarikat S2). Program ini mendapat dana daripada CSR wakaf sebanyak RM80,000 dan dana zakat (Informan B4, 2019). Selain itu, program takaful mikro turut diperluas sumber dana melalui sumbangan Ihsan rider serta sumbangan ikhlas daripada para pekerja melalui inisiatif Giving @ Workplace (Informan B3, 2019). Syarikat S3 turut bekerjasama dengan Unit Penyelaras Pelaksanaan (*Implementation Coordination Unit, ICU*), Jabatan Perdana Menteri di Malaysia untuk mendapatkan maklumat golongan miskin yang telah didaftarkan di dalam pangkalan data eKasih (Laman rasmi Syarikat S2).

Berdasarkan penilaian model oleh P1, pelaksanaan model ini mempunyai masalah dari sudut undang-undang dalam penggunaan dana wakaf dan zakat yang memerlukan kebenaran MAIN. Walaupun secara realiti, memang terdapat syarikat-syarikat korporat yang tidak membayar zakat kepada Pusat Zakat. Hal ini menyalahi undang-undang bergantung kepada keberanian syarikat tersebut untuk berhadapan masalah undang-undang ini. Oleh itu, P1 mencadangkan agar pihak MAIN memberi kebenaran syarikat korporat untuk menguruskan pengagihan sendiri dengan pemantauan daripada pihak MAIN supaya dana zakat masih disalurkan kepada kumpulan asnaf yang layak seperti yang dibincangkan dalam model penggunaan dana zakat sebelum ini (laman rasmi syarikat S3, 2019).

Berdasarkan penilaian model oleh P3 menyatakan bahawa model dana daripada pelbagai sumber tiada sebarang isu yang penting agihan bahagian zakat jelas diberikan kepada asnaf. Dana Wakaf CSR sebanyak RM80,000 juga tiada masalah dari sudut syarak kerana dana wakaf yang dilaburkan dan jumlah asal dana wakaf juga adalah kekal.

Namun, masalah yang timbul adalah isu undang-undang bagi model ini dari sudut pembayaran zakat secara terus tanpa melalui bahagian zakat negeri dan bagi penggunaan dana wakaf pula perlu mendapatkan kebenaran MAIN sebagai pengurus wakaf iaitu mutawalli. Oleh itu, penggunaan dana zakat dan wakaf menghadapi masalah undang-undang yang telah ditetapkan oleh pemimpin atau MAIN bagi model ini (Penilai P3, 2019).

Analisis Penilai Model

Berdasarkan penilaian model oleh penilai P1 dan P3, kedua-dua penilai menyatakan model ini mempunyai masalah dari aspek undang-undang kerana pembayaran zakat dilakukan secara terus kepada asnaf tanpa melalui bahagian zakat di MAIN. Bagi CSR Wakaf P3 juga menyatakan perlu mendapat kebenaran mengurus wakaf iaitu sebagai mutawalli daripada bahagian wakaf MAIN. Namun begitu, P3 turut menyatakan bahawa model ini tiada masalah dari sudut syarak bagi pengagihan zakat dan pengurusan wakaf bagi model ini kerana agihan zakat telah diagihkan kepada asnaf yang layak di bawah senarai eKasih dan pengurusan wakaf juga digunakan hasil keuntungan daripada pelaburan dan jumlah asal wakaf adalah kekal. Oleh itu, model ini mempunyai potensi untuk dilaksanakan selaras dengan beberapa kajian oleh Noor Ashikin Mohd Rom dan Zuriah Abdul Rahman, (2012), Haslifah Mohamad Hasim (2014a), James Midgley (2012), Christian Biener dan Martin Eling (2012), Marleen Dekker dan Annegien Wilms (2010), Yi (Kitty) Yao (2013), dan Wendy J. Werner (2009) yang mencadangkan penggunaan dana daripada pelbagai sumber untuk penawaran takaful mikro.

6.0 KESIMPULAN

Penawaran takaful mikro dapat ditawarkan dengan mempunyai dana tambahan daripada wakaf, zakat, CSR dan lain-lain sumber yang dikendalikan oleh syarikat takaful. Hal ini tidak mustahil untuk dilakukan kerana pelaksanaan telah pun dilakukan di peringkat syarikat takaful. Namun, belum dilakukan secara khusus kepada penawaran warga emas. Oleh itu, penawaran takaful mikro kepada warga emas dapat ditawarkan kepada golongan ini untuk mendapat perlindungan takaful.

7.0 CADANGAN KAJIAN MASA HADAPAN

Berdasarkan perbincangan dalam artikel ini didapati terdapat aspek-aspek yang boleh dikaji untuk tujuan penyelidikan pada masa akan datang seperti berikut:

- 1) Kajian lanjutan boleh dilakukan dengan mengkaji potensi penawaran produk takaful mikro kepada warga emas dengan kerjasama syarikat takaful dan Majlis Agama Islam Negeri (MAIN) di seluruh negeri di Malaysia.
- 2) Kajian lanjutan boleh dilakukan dengan mengkaji kajian secara kuantitatif untuk mengetahui pandangan, perspektif, sambutan masyarakat terhadap penawaran takaful mikro kepada warga emas.
- 3) Kajian lanjutan boleh dilakukan dengan mengkaji potensi penawaran produk takaful mikro kepada warga emas dengan kerjasama kerajaan negeri di seluruh Malaysia.

PENGHARGAAN

Artikel ini merupakan output penyelidikan di bawah Geran Penyelidikan Universiti Malaya (UMRG Programme)-HNE (Humanities & Ethics) bertajuk "Microtakaful as an Islamic Financial Instrument: A Study of the Elderly Muslim in Malaysia" (RP028A-16HNE). Penghargaan ditujukan kepada biasiswa Sasakawa Young Leaders Fellowship Fund (SYLFF) di bawah unit biasiswa dan tajaan, Universiti Malaya; Bank Negara Malaysia (BNM), syarikat takaful, penilai model atas kerjasama yang diberikan.

RUJUKAN

- Agensi Kaunseling dan Pengurusan Kredit (AKPK). (2014). *Celik Wang Pengurusan Wang secara Bijak*. Kuala Lumpur: Agensi Kaunseling dan Pengurusan Kredit (AKPK). Edisi Kedua, 73.
- Agro Bank. Produk C. Laman sesawang Agro Bank, dicapai pada 06 April 2019, <https://www.agrobank.com.my/product/agro-mabrur-i/>
- Ahmed MH. (2016). *Micro Takaful Insurance as a Tool to Guaranteeing Financing and Protecting Micro Enterprises*. Journal Business & Financial Affairs, Vol.5, Issue 4, 2.
- Asiah Kamal, Ahmad Azam Sulaiman@Mohamad, Mohammad Taquuddin Mohamad. (2017). *Takaful Mikro Bagi Warga Emas Sebagai Instrumen Kewangan Islam: Satu Kajian Literatur*. Journal of Muslim Affairs (UMRAN), Vol.3, No.2, 59.
- Bernama. Cabaran Negara Tangani Masyarakat Warga Tua. Laman sesawang Malaysiakini, dicapai pada 06 Mei 2018, <https://www.malaysiakini.com/news/294177>.
- Christian Biener dan Martin Eling. (2012). *Insurability in Microinsurance Markets: An Analysis of Problem and Potential Solutions*. The Geneva on Risk and Insurance, No.37, 96.
- Craig Churchill. (2007). *Insuring the Low-Income Market: Challenges and Solutions for Commercial Insurers*. The Geneva Papers on Risk and Insurance, No.32, 403.
- Daniel J. Clarke dan Dermot Grenham. (2013). *Microinsurance and Natural Disasters: Challenges and Options*. Environmental Science and Policy, No.27, S90.
- Fatin Nabilah Abdul Wahid dan Kamaruzaman Noordin. (2014). *Skim Takaful Sumbangan Rendah serta Prospek pelaksanaan takaful Mikro di Malaysia*. International Conference on Postgraduate Research (ICPR), 2014,31.
- Hasliyah Mohamad Hasim. (2014a). *Developing a Conceptual Framework of Microtakaful as a Strategy towards Poverty Alleviation*. Journal of Economics and Sustainable Development, Vol.5, No.28,1.
- Hasliyah Mohamad Hasim. (2014b). *Microtakaful as an Islamic Financial Instrument, for Poverty Alleviation in Iraq*, Middle-East Journal of Scientific Rerearch 21, 2315.
- Institut Penyelidikan Penuaan Malaysia Universiti Putra Malaysia. (2017). *Kajian Kemudahan dan Perkhidmatan bagi menepati keperluan warga emas menjelang 2030*. Putrajaya: Jabatan Kebajikan Masyarakat Malaysia. 527-528.
- James Midgley. (2012). *Social Protection and The Elderly in The Developing World: Mutual Aid, Micro-Insurance and The State*. Journal of Comparative Social Welfare, Vo.28, No.2, 157, 160-161.
- Jamil Ramly et al., (2010). *Buku Panduan Asas Takaful*. Kuala Lumpur: IBFIM, 58-59.
- KHLAS Waqf & Endowment. Produk Kami. Laman sesawang syarikat S3, dicapai pada 20 Jun 2019. <https://www.takaful-ikhlas.com.my/ms/produk-kami/ikhlas-waqfendowment-iwe>.
- Malaysian Takaful Association (MTA). Perlindungan Tenang. Laman sesawang Malaysian Takaful Association (MTA), dicapai pada 07 November 2019. <http://www.malaysiantakaful.com.my/Consumer-Zone/Perlindungan-Tenang.aspx>
- Marleen Dekker dan Annetgen Wilms. (2010). *Health Insurance and Other Risk-Coping Strategies in Uganda: The Case of Microcare Insurance Ltd*. World Development, Vol.38, No.3, 370.
- Michal Matual et.al, (2013). *Microinsurance Demand: Determinants and Strategies*. Enterprise Development and Microfinance, Vol.24, No.4, 316.
- Nikunj Kumar Gor. (2013). *Microtakaful-Islamic Insurance for Deprived: Innovation, Sustainability and Inclusive Growth*. International Journal of Business, Economics and Law, Vol.3, Issue 2, 24.
- Nooh Gadot. (2014). *Transformasi Pengurusan Wakaf. Pemangkin Sosial Ekonomi Ummah*. Seminar Waqaf Antarabangsa, Johor. 10.
- Noor Ashikin Mohd Rom dan Zuriah Abdul Rahman. (2012). *Financial Protection for the Poor in Malaysia: Role of Zakah and Micro-takaful*. Journal of King Abdulaziz University, Islamic Economic, Vol.25, No.1, 123.
- Noor Ashikin Mohd Room dan Zuriah Abdul Rahman. (2014). *Reformation of Islamic Insurance: Policy Making to Ensure Economic Sustainability for The Lower Strata of Society*. Asian-African Journal of Economics and Econometric, Vol.14, No.1, 78.
- Oscar Joseph Akotey, Kofi A. Osei dan Albert Gemegah. (2011). *The Demand for Micro Insurance in Ghana*. The Journal of Risk Finance, Vol. 12 Issue.3, 191.
- Patty Jansen, Tobias Gösling dan Toon Bullens. (2011). *Toward Shared Social Responsibility: A Study of Consumers' Willingness to Donate Micro-Insurance when Taking Out Their Own Insurance*, Journal of Business Ethics, no.100, 175.
- Portal Rasmi Bahagian Pasca Perkhidmatan Jabatan Perkhidmatan Awam (JPA). Apakah Takrifan Warga Tua di Malaysia?. Laman sesawang jpapencen, dicapai 25 Mac 2018, http://www.jpapencen.gov.my/takrifan_warga_tua.html.
- Produk A. Dokumen Produk. Laman sesawang syarikat S1, dicapai pada 24 Oktober 2019. https://www.aia.com.my/content/dam/my/en/ecommerce/pds/general/starter_plan_takaful_bm_pds.pdf?staterplan/faq.html?faq=908550191-21
- Produk A. Soalan-Soalan Lazim Produk A. Laman sesawang syarikat S1, dicapai pada 24 Oktober 2019. <https://www.aia.com.my/ms/our-products/life-protection/aia-i-starter-plan/faq.html?faq=908550191-21>.
- Produk B. Ciri-Ciri dan Manfaat Pelan. Laman sesawang Syarikat S2, dicapai pada 24 Oktober 2019. <https://app.prubsn.com.my/online/customer.html#pruFAQ>.
- Produk B. Dapatkan Sebut Harga untuk Produk B. Laman sesawang syarikat S2, dicapai pada 24 Oktober 2019. <https://app.prubsn.com.my/online/customer.html#pruInstantQuote>.
- Produk B. Sumbangan dan Caj. Laman sesawang syarikat S2, dicapai pada 24 Oktober 2019. <https://app.prubsn.com.my/online/customer.html#pruFAQ>.
- Produk B. Mengenai Produk B. Laman sesawang syarikat S2, dicapai pada 5 Nov 2019. <https://www.prubsn.com.my/ms/our-company/caring-for-society/>.
- Rebekah Yore dan Joanna Faure Walker. (2019). *Microinsurance for Disaster Recovery: Business Venture or Humanitarian Intervention? An Analysis of Potential Success and Failure Factors of Microinsurance Case Studies*. International Journal Disaster Risk Reduction, No.33, 26.
- Said Adekunle Mikail, Muhammad Ali Jinnah Ahmad, Salami Saheed Adekunle. (2017). *Utilisation of Zakāh and Waqf Fund in Micro-Takāful Models in Malaysia: An Exploratory Study*. ISRA International Journal of Islamic Finance, Vol. 9, Issue: 1,104.
- Seiro Ito dan Hisaki Kono. (2010). *Why is The Take-up of Microinsurance so Low? Evidence from A Health Insurance Scheme in India*. The Developing Economics 48, No.1, 74.
- Sheila Nu Nu Htay and Nur Shazwani Sadzali. (2015). *An Analysis of the Viability of Micro Health Takaful in Malaysia*. Journal of Islamic Accounting and Business Research, Vol.4, Issue 1, 63, 37.
- Siti Mashitoh Mahmood, Asmak Ab Rahman dan Azizi Che Seman. (2018). *Pembentukan Institusi Pengajian Tinggi Berteraskan Wakaf di Malaysia: Cadangan Model Pelaksanaannya*. Jurnal Syariah, Jil.26, Bil.1, 13.
- Syarikat S3. Produk C. Risalah (2017). Kuala Lumpur: Syarikat S3.

- Tajudeen Olalekan Yusuf (2012). *The Role of Islamic Micro Insurance in Economic Growth and Development: The Nigerian Experience: A Case Study of Al-Barakah Microfinance Bang, Lagos*. International Journal of Business and Commerce, Vol.1, No.10, 108.
- Vishal Pinto. (2015). *Role of NGOs in Promoting Micro Health Insurance: A Study with Reference to 'Sampoorna Saraksha' Health Insurance Scheme by SKDRDP, Mangalore (India)*. South Asia Journal of Business and Management Cases, Vol.4, No.2, 252.
- Wan Norhayate Wan Daud et.al., (2016). *MicroTakaful Flood Scheme in Malaysia: Alternative Approach to Takaful Operators*. Terengganu: Penerbit Universiti Sultan Zailnal Abidin. 122.
- Wendy J. Werner. (2009). *Micro-insurance in Bangladesh: Risk Protection for the Poor?*. Journal of Health, Population and Nutrition, Vol.27, No.4, 571.
- Yi (Kitty) Yao. (2013). *Development and Sustainability of Emerging Health Insurance Markets: Evidence from Microinsurance in Pakistan*. The Geneva Papers, No.38, 178.
- Yung-Ping Chen. (1987). *Making Assets out of Tomorrow's Elderly*. The Gerontologist, Vol.27, No.4, 416.

TEMU BUAL

- Informan BNM. (2019, Feb 15). Penganalisis, Jabatan Perbankan Islam dan Takaful, Bank Negara Malaysia. Temu bual. Kuala Lumpur.
- Informan A1. (2019, Mei 6). Penolong Pengurus, Jabatan Pemasaran Produk, Syarikat S1. Temu bual. Kuala Lumpur.
- Informan B1. (2019, Mei 15). Ketua, Jabatan Pemasaran Takaful Mikro dan CSR, Syarikat S2). Temu bual. Kuala Lumpur.
- Informan B2. (2019, Mei 15). Pengurus, Jabatan Pemasaran Takaful Mikro dan CSR (Produk), Syarikat S2). Temu bual. Kuala Lumpur.
- Informan B3. (2019, Mei 15). Pengurus, Jabatan Pemasaran Takaful Mikro dan CSR (CSR), syarikat S2). Temu bual. Kuala Lumpur.
- Informan B4. (2019, Okt 30). Jabatan Syariah, Syarikat S3. Temu bual. Kuala Lumpur.
- Informan C1. (2019, Jun 12). Naib Presiden, Jabatan Bancatakaful, syarikat S3. Temu bual. Kuala Lumpur.
- Informan C2. (2019, Jan 15). Naib Presiden, Jabatan Syariah, syarikat S3. Temu bual. Kuala Lumpur.

PENILAI MODEL

- Penilai P1. (2019, Mei 24). Naib Presiden, Jabatan Syariah, syarikat S3. Temu bual. Kuala Lumpur.
- Penilai P2. (2019, Ogos 23). Penasihat Syariah, Wakaf Selangor Muamalat. Temu bual. Kuala Lumpur.
- Penilai P3. (2019, Ogos 28). Penasihat Syariah, Zurich Takaful. Temu bual. Kuala Lumpur.

THE ROLE OF COMPETITION AS A MEDIATOR BETWEEN FINANCIAL LIBERALIZATION AND FINANCIAL STABILITY: ISLAMIC BANKS VS CONVENTIONAL BANKS

Nur Afizah Muhamad Arifin^{*a}, Noraini Mohd Arifin^b, Zulkufly Ramly^c & Maryam Jameelah Hashim^d

^{ad}Faculty of Business and Management, Universiti Teknologi MARA, Malaysia

Institute of Islamic Banking and Finance, IIUM, Gombak, Malaysia

^{b,c}Kulliyah of Economics and Management Sciences, IIUM, Gombak, Malaysia

ABSTRACT

Banking sector act as financial intermediary play a crucial role in the mobilizing the fund between the surplus and deficit unit. However, global financial market has witnessed dramatic change due to shifting from financial repression to financial liberalization that lead to a cross border capital flows and the development of financial sector. Financial liberalization will induce competition and an impact towards financial stability due to the excessive risk taking. This paper aims to analyze the effect of competition on the relationship between financial liberalization and financial stability. A comparison between Islamic and conventional banks is being analyzed. PLS-SEM is used to analyze the research model. This research theoretically contributes to the extension of competition stability view and competition fragility view in predicting the financial stability. The empirical results indicate that there is a significant effect of financial liberalization towards financial stability with the interaction of competition for conventional banks. However, for Islamic banks it is significant but negatively related with the interaction of competition.

Key Words: Competition, Financial Liberalization, Financial Stability

1.0 INTRODUCTION

The global financial system has witnessed dramatic change due to shifting from financial repression to financial liberalization that lead to a cross border capital flows and the development of financial sector. Therefore shifting from financial repression to financial liberalization ie the deregulation or financial reform of domestic financial market will affect the stability of the financial system due to the reform in the banking policy. The pace of financial liberalization has to be in tandem with capacity and ability of the system to absorb these changes without undermining the financial stability (BNM, 1999). Arteta, Eichengreen and Wyplosz (2001) Fuchs-Schündeln and Funke (2001) argued that in the financial liberalization regime, the financial stability could be achieved through financial development, which facilitates economic growth of the financial sector and product innovation. On the other hand, financial liberalization also has been identified as source of financial instability and lead to financial crisis (Hamdaoui, 2017) this is because with more integrated system due to financial liberalization not only the return will increase but the risk will also be increase because it will affect the bank behavior to take risk by giving more financing to the customer Cubillas & González (2014).

The theory of financial liberalization is from the seminal works of McKinnon (1973) and Shaw (1973), who argued that financial repression undermined economic growth in developing countries and proposed the use of financial liberalization policies to promote savings, investment and economic growth. Mckinnon (1973) and Shaw (1973) found that financial liberalization could exert a positive impact on growth rates as interest rate levels raise their competitive market equilibrium, while resources are efficiently allocated. Liberalization of the financial system is done by deregulates the interest rate, removal of the barriers on the capital flows and removal of the barrier on competition among the financial institutions (Allegret, Courbis, & Dulbecco, 2003). Therefore, Financial liberalization will induce Competition. The theory that can link competition and financial stability are competition stability and competition fragility. Under competition fragility view proposed by Keeley (1990), the pressure of competitive environment with more pressure on profit, banks have higher incentives to take more excessive risk. Banks tend to increase in their risk-taking activities by financing riskier project for higher return. Therefore when the bank increases their risk it will reduce the value of the firmie the charter value. This will result in higher fragility (Beck, 2008). While under the competition fragility predicts that less competitive banking systems are more stable,

an opposing view is that more competition will result on stability. The competition stability view by Boyd and De Nicolo (2005), argued with less competition ie more concentrated market in the loan market result in higher cost of borrowing for consumer from the monopoly bank. Therefore the credit risk to the bank will increase because of higher interest cost.

Bank will make excessive risk to compete among them in the banking industry. Banks excessive risk-taking behavior is also due to selling of financing products from market to tradable securities or securitization. By selling the financing products the banks will receive cash through securitization and more new transactions for their business can be generated. Banks can give more financing and earning through new financing transaction because the banks need to compete. For this reason, financial liberalization is usually followed by boom-bust cycle (Ramirez, 2007) because it will stimulate economic activities supported by lending activities. During this cycle banks expand its credit by taking excessive credit risk due to the increase in lending activities and competition. This is supported by research from Gruben, Koo and Moore (2003) and Daniel and Jones (2007), they conclude that banks are more likely to fail in a liberalized regime due to less regulated banking system.

The effect of financial liberalization on financial stability of Islamic banks versus conventional banks is an issue to be further researched. The principles of Islamic shariah law and the transparency of the contract make the operation of Islamic and conventional banks different in terms if asset liability structure and product offering (Ashraf, Rizwan and L'Huillier, 2016). The assets liability structure of a bank will determine the risk taking (IMF, 2011). As an example, for Islamic banks, the concept of profit and loss sharing (PLS) non profit and loss sharing is being used for their assets and liabilities activities. Under PLS the credit risk from the banks can be shifted to the investment holders rather than the debt holder. The negative shock on the assets sides can be pass through to the investment depositors using the concept of PLS where the depositors will share the risk with the bank (Čihák and Hesse, 2010). However, the exposure is will be on how the Islamic banks can offer competitive rate in order to compete in the dual banking environment. Thus, with these two parallel systems it is important to compare between Islamic and conventional banks because given that they operate in the same regulatory environment it is vital to look whether the exposure is the same or not both types of the banks. Financial liberalization will induce competition therefore by comparing between conventional and Islamic bank is to look at whether with competition it is favorable or unfavorable for the banks operating in this dual banking system.

2.0 LITERATURE REVIEW

Financial and banking sector has encountered several profound changes such as financial liberalization that affect bank's operations and also have an impact on stability of the banks. Consequently, financial stability was put under questions many times and important aspect that has to be analyzed is represented by the bank stability. Financial stability can be defined as the banks' ability to efficiently allocate resources in order to manage financial risk (Diaconu and Oanea, 2015). Nosheen and Rashid (2020), This paper empirically investigate the financial stability of the countries having both Islamic and conventional banks versus the countries having only conventional banks. It also examines the ability of Islamic banks to provide stability to the overall financial system. The results provide sound evidence that the dual banking system is more stable than the single banking system. Higher stability is attributed to the presence of Islamic banks in the dual banking system. Furthermore, when only the dual banking system is investigated, the results strongly confirm the greater stability of Islamic banks as compared to their conventional counterparts. Although Islamic banks are mimicking conventional banking practices, their increased interactions with the real economy, investments in real assets, non-aggressive lending profile, and limited exposures to speculative activities make them more resilient and protected.

Financial and banking sector has encountered several profound changes such as globalization and deregulation due to financial liberalization. Financial liberalization literature starts from Mckinnon (1973) and Shaw (1973) where they critique on the financial repression that will distort the economic growth. According to Mckinnon (1973) and Shaw (1973) financial liberalization is the effective ways to develop banking intermediation by accumulation of the capital in order to promote economic growth in the country. Economic growth must be at tandem to preserved the financial stability of the banking sector. Beck (2008) and Kaminsky and Schmukler (2003) have noted that financial liberalization has often been blamed for subsequent banking fragility in many developed and developing countries. Ang (2011) also find that while financial development facilitates the accumulation of new ideas, the implementation of financial reform policies is negatively associated with it. According to Ang (2011), the undesirable effects of financial liberalization are found to operate through the triggering of crises and volatility in the financial system.

Financial liberalization regimes have changed the competitive conditions in the banking sector in both the developed and developing countries. The theoretical banking literature reflects competition as an important channel through which financial liberalization affects financial stability (Lee & Hsieh, 2014; Abderzag & Hasnaoui, 2015). Banks

will face competition on both sides of the statement of financial position that is the depositors and the financing and thus, create exposure to the assets and liabilities. The theoretical discussion that link between the relationship between competition and financial stability that are competition fragility or known as the franchise value paradigm (Keeley, 1990) and competition stability (Boyd and De Nicolo, 2005). Competition fragility argues that smaller banks in the competitive systems tend to take excessive risk and therefore, the systems are more fragile. While, under competitive stability, more competitive or less concentrated banking systems are more stable. Competition can enhance bank stability through efficiency, promoting new product innovation and enhancing loan portfolio diversifications (Fiordelisi & Mare, 2014; Boyd, De Nicolo & Jalal, 2006). The competition-fragility view, which is also called the franchise value paradigm, was proposed by Keeley (1990). The main idea of this view is that higher bank competition increases bank's risk-taking incentives.

The empirical literature on the relationship between competition and stability has also produced mixed results. Fiordelisi and Mare (2014) postulated evidence in line with the competition-stability view as proposed by Boyd and De Nicolò (2005) and found that there is a positive relationship between competition and stability even during 2007-2009 financial crises. Cubillas and Gonzales (2014) analyzed the channels through which financial liberalization affects bank risk taking in an international sample of 4,333 banks in 83 countries. By combining 2SLS procedure with GMM estimators, empirical result reveals that financial liberalization will increase bank risk taking. Nevertheless, in developing countries financial liberalization negatively impact banks stability. The instability is defined as risk or insolvency risk, which is not as results of changes in bank competition but by expanding opportunities to take risk. Azkunaga, Jose and Urionabarrenetxea (2013), analyzes the ways in which the financial globalization and financialization of the economy through the governance of banking institutions contributed to the development and outbreak of the crisis. The competition pressures banks to adopt strategies to diversify and this decision affects bank insolvency risk. Boyd et al. (2006) provide empirical evidence supporting a positive relationship between banks' market power and banks' failure risk. Employing HHI to measure bank competition and capturing bank risk using the Z-score, they examine two samples: a cross-section of 2500 small rural banks operating in the U.S. and a panel of 2700 banks from 134 countries, excluding developed countries. In both samples, they find a negative and significant relationship between stability and competition.

Financial liberalization will enhance competition, and banks need to be competitive. The exposure is that there is a tendency of assets liability mismatch due to the adjustment of the interest rate that being liberal. Financial liberalization promotes economic growth. In order for the economic to develop the function of financial intermediaries must be well function and stable so that the economic can develop. Therefore the competition and deregulation of the interest rate support the financial liberalization and it will affect the relationship between financial liberalization and financial stability. Thus it will lead the banks to become insolvent. Theory of financial stability, financial liberalization, competition stability and fragility can be link as in figure 1.



Figure 1: Theoretical Framework

The hypotheses developed for this paper are as follows:

- H1: Competition mediate the relationship between financial liberalization and financial stability for Islamic banks
 H2: Competition mediate the relationship between financial liberalization and financial stability for Conventional banks

3.0 RESEARCH METHODOLOGY

This study adopts secondary data in quantitative approach in analyzing the financial stability in Malaysia. The secondary data is collected from Bankscope database of Bureau van Dijk's and FitchConnect. This study uses annual data from year 1996 to 2017. The sampling criterion for this study is to include all banks including Islamic and conventional banks in Malaysia, from 1996 to 2017. Selected data set will consist of unbalanced panel data. Structural equation model – Partial least square (SEM – PLS) method being employed.

4.0 ANALYSIS OF RESULTS

4.1 Measurement Model

Table 1 and table 2 presents the results of the measurement models (formative construct) for Islamic and conventional banks in Malaysia. PLS-SEM is the preferred approach when formative constructs are included in the

structural model (Hair et al., 2019). Formative measurement models are evaluated based on the following: convergent validity, indicator collinearity, statistical significance, and relevance of the indicator weights (Hair et al., 2017.). Convergent validity is assessed by the correlation of the construct with an alternative measure of the same concept. Originally proposed by Chin (1998), the procedure is referred to as redundancy analysis. When the model is based on secondary data, a variable measuring a similar concept would be used (Houston, 2004). Hair et al. (2017a) suggest that the correlation of the formatively measured construct with the single-item construct, measuring the same concept, should be 0.70 or higher.

The variance inflation factor (VIF) is often used to evaluate collinearity of the formative indicators. VIF values of 5 or above indicate critical collinearity issues among the indicators of formatively measured constructs. However, collinearity issues can also occur at lower VIF values of 3 (Mason and Perreault, 1991; Becker et al., 2015). Ideally, the VIF values should be close to 3 and lower. When the model is based on secondary data, a variable measuring a similar concept would be used (Houston, 2004). In table 1 all formative construct fulfilled VIF threshold for Islamic banks. Table 2 the VIF ROA and ROEA for conventional banks are above the threshold of 0.70. Hair et al. (2017a) suggest that the correlation of the formatively measured construct with the single-item construct, measuring the same concept, should be 0.70 or higher.

As shown in table 1 the ROAE for Islamic banks is not significant. The ROAE for conventional banks also not significant as per table 2 even one item is not significant that is ROAA but it is acceptable because the ROAA is part of the component to calculate the financial stability. The results from the bootstrapping must indicate that the outer weight from each formative indicator is significant. If the indicator is not significant, it can still be retained on the basis of content validity (Hair et al, 2017). On the other hand, researchers can omit the formative indicators when the outer loading is <0.5 and not significant (Hair et al,2017)

Table 1: Convergent validity, indicator collinearity and statistical significance for Islamic banks

CONSTRUCT	ITEM	CONVERGENT VALIDITY	WEIGHTS	VIF	t-VALUE WEIGHTS	SIG
FINANCIAL STABILITY	ROAA	0.805	-0.316	1.241	1.273	0.204
	ROAE		0.069	1.244	0.320	0.749
	ZSCORE		0.975	1.011	16.461	0.000

Table 2: Convergent validity, indicator collinearity and statistical significance for conventional banks

CONSTRUCT	ITEM	CONVERGENT VALIDITY	WEIGHTS	VIF	t-VALUE WEIGHTS	SIG
FINANCIAL STABILITY	ROAA	0.760	-0.316	9.491	2.410	0.016
	ROAE		0.069	9.360	0.275	0.783
	ZSCORE		0.975	1.046	16.105	0.000

4.2 Structural Model

In this study, the structural model indicates the causal relationships among constructs in the model. Table 5 depicts the results of the hypothesized model test. As for the relationship of competition between financial liberalization and financial stability, the bootstrapping analysis showed in table 5 that the indirect effect $\beta = -0.025$ is significant with a t-value of 2.030 for conventional banks, while for Islamic banks the indirect effect $\beta = -0.024$ is significant with a t-value of 1.720. In addition, as indicated by Preacher and Hayes (2008), the indirect effect (-0.025, 95% Boot CI: [LL = 0.000, UL = 0.010]) for conventional banks and for Islamic banks (-0.024, 95% Boot CI: [LL = -0.055, UL = -0.012]) does not straddle a 0 in between, thus indicating a mediation effect. From the results in Table 5, we can conclude that the mediation effect is statistically significant, thus confirming that H1 and H2 (the relationship between financial liberalization and financial stability is significantly mediated by competition) are supported.

The empirical analysis shows that the effect of the bank concentration measured by HHI as the mediating variables between the financial liberalization and financial stability is negative and highly significant for conventional banks

but slightly significant for Islamic banks at five percent level. Hence, this study supports the competition stability view where the lower the HHI index meaning lower concentration and high competition leads to higher financial stability. This suggests that with higher competition lead to financial stability because the bank is more efficient in a competitive setting for both conventional and Islamic banks. Therefore, this study contributes to the extension of competition stability and fragility view in predicting the financial stability. The findings suggested the competition interacts the relationship between financial liberalization and financial stability. The finding reveals that for Islamic banks, the mediating variables giving negative significant effect to the financial stability. Meaning that the Islamic banks are more stable if the market is fully concentrated or less competitive. This supported by Aris (2010) Islamic banking market exhibits more concentration and less competition compared to the conventional banking segment. Competitive fragility view the banks may develop riskier activities in higher return, but for Islamic banks they are constraint by the shariah principles that limit them to diversify the risk. Thus these reflect with competition the market cannot be to liberal because it will have a negative effect on financial stability.

Table 5: Path Coefficient and Hypotheses testing

Hypothesis	Relationship	Std Beta	T-value	P-values	LL	UL	Supported
H1 (islamic banks)	Financial liberalization -> Competition-> Stability	-0.024	1.720	0.043	-0.055	-0.012	YES
H2 (conventional banks)	Financial liberalization -> Competition-> Stability	-0.025	2.030	0.021	0.000	0.010	YES

5.0 CONCLUSION AND DISCUSSION

The result shows that the knowledge of competitive issues is crucial so that policy makers may formulate the new policies for the banking industry that suit the current market structure. With the comparison study between Islamic banks and conventional banks from this study it shows that competition is important in order to improve stability for both Islamic and conventional banks. Competitive conditions in banking are relevant for at least two reasons. The degree of market power may bear serious implications for financial stability theoretical predictions and empirical evidence that more market power might result in higher bank risk (Stiglitz & Weiss, 1981; Koskela & Stenbacka, 2000; Boyd & De Nicolo, 2005; Schaeck, Cihak, & Wolfe, 2009). The findings show that the growth of competition is more intense in the Islamic banking market. This gives a signal to policy a maker that now is the time to allow the Islamic banks to operate independently without the control of their parent banks that are conventional practitioners. Besides, bank managers should constantly monitor the services offered as to provide a positive market signal to customers; and thereby ensuring the survival of their banks in the increasing competitive market.

REFERENCES

- Allegret J.P., Courbis B., Dulbecco Ph. (2003), "Financial Liberalisation and Stability of the of the Financial System in Emerging Markets: the Institutional Dimension of Financial Crises", *Review of International and Political Economy* 10, 1, February, pp.73-92.
- Arteta Carlos, Eichengreen Barry and Wyplosz Charles (2001), When Does Capital account liberalization help more than it hurts?. Working paper 8414, <http://www.nber.org/papers/w8414>, National Bureau of Economics Research.
- Ashraf Dawood, Rizwan Muhammad Suhail and L' Huillier, Barbara (2016), a net stable funding ratio for islamic banks and its impact of financial stability: an international investigation, *Journal of financial stability*, 2016, volume 25, issue C, 47-57
- Ang James B (2011), Financial development, liberalization and technological deepening, *European Economic Review*, [Volume 55, Issue 5](#), June 2011, Pages 688-701
- Abderzag & Hasnaoui (2015).The impact of financial liberalization on the stability of the financial system in emerging market s Mediterranean. *Journal of social sciences Vol 6 No 6 2015*
- Beck (2008), Bank Competition and Financial Stability: Friends or Foes?, The World Bank Policy and Research Working Paper 5981
- Boyd, J.H., De Nicolo, G., 2005. The theory of bank risk taking and competition revisited. *J. Financ.* 60 (3), 1329–1343
- Cubillas and Gonzales (2014).Financial liberalization and bank risk taking. *International evidence journal of financial stability* 11 (2014) 32 – 48
- Daniel and Jones (2007). Financial liberalization and banking crises in emerging economies. *Journal of international economics*, volume 72, issue 1, may 2007, pages 202 – 221
- Cihak, M., Hesse, H., 2010. Islamic banks and financial stability: an empirical analysis. *J. Financ. Serv. Res.* 38, 95–113
- Diaconu ioana-Raluca, Oanea Dumitru-cristian (2015), Determinants of banks' stability. Evidence from Creditcoop, *Procedia Economics and Finance* 32 (2015) 488 – 495
- Fuchs-Schundeln and Funke Norbert (2002), Stock Market liberalizations: Financial and Macroeconomic implications, IMF working paper No 01/193, International Monetary fund (IMF)- Africa department
- Gruben, W., Koo, J., Moore, R., 2003. Financial liberalization, market discipline and bank risk. CLAE Working Paper, vol. 0303
- Hamdaoui Mekki (2017), Financial liberalization and systemic banking crises: A meta analysis. *International Economics Volume 152*, December 2017, pages 26-54
- Hair, J. F., Ringle, C. M., & Sarstedt, M. (2011). PLS-SEM: Indeed a Silver Bullet. *The Journal of Marketing Theory and Practice*, 19(2), 139–152. <https://doi.org/10.2753/MTP1069-6679190202>
- Hair, J. F., Hult, G. T. M., Ringle, C. M., Sarstedt, M., & Thiele, K. O. (2017). Mirror, mirror on the wall: a comparative evaluation of composite-based structural equation modeling methods. *Journal of the Academy of Marketing Science*, 1–17. <https://doi.org/10.1007/s11747-017-0517-x>
- Hair, J.F., Hult, G.T.M., Ringle, C.M. and Sarstedt, M. (2017a), A Primer on Partial Least Squares Structural Equation Modeling (PLS-SEM), Sage, Thousand Oaks, CA
- Hair, J.F., Sarstedt, M., Ringle, C.M. and Gudergan, S.P. (2018), Advanced Issues in Partial Least Squares Structural Equation Modeling (PLS-SEM), Sage, Thousand Oaks, CA.
- Hair, J. F., Ringle, C. M., & Sarstedt, M. (2013). Partial Least Squares Structural Equation Modeling: Rigorous Applications, Better Results and Higher Acceptance. *Long Range Planning*, 46(1–2), 1–12. <https://doi.org/10.1016/j.lrp.2013.01.001>
- Hair J.F., Black W.C., Babin B.J., Anderson R.E., and Tatham R.L. (2006). *Multivariate data analysis 6th Edition*. Pearson Prentice Hall. New Jersey.
- Hair, J. F., Sarstedt, M., Hopkins, L., & Kuppelwieser, V. G. (2014). Partial least squares structural equation modeling (PLS-SEM). *European Business Review*, 26(2), 106–121. <https://doi.org/10.1108/EBR-10-2013-0128>
- Hair, J.F., Sarstedt, M. and Ringle, C.M. (2019), "Rethinking some of the rethinking of partial least squares", *European Journal of Marketing*, Forthcoming.
- Hair, J. F., Sarstedt, M., Pieper, T. M., & Ringle, C. M. (2012). The Use of Partial Least Squares Structural Equation Modeling in Strategic Management Research: A Review of Past Practices and Recommendations for Future Applications. *Long Range Planning*, 45(5–6), 320–340. <https://doi.org/10.1016/j.lrp.2012.09.008>
- Kaminsky, G., Schmukler, S.L., 2003. Short-run pain, long-run gain: the effects of financial liberalization. IMF Working Paper WP/03/34.
- Keeley, M.C., 1990. Deposit insurance, risk, and market power in banking. *Am. Econ. Rev.* 80, 1183–1200
- Lee and Hsieh (2014). Bank reforms, foreign ownership and financial stability. *Journal of international money and finance* 40(2014) 204 – 224
- McKinnon, Ronald I. (1973). *Money and Capital in Economic Development*. (Washington: The Brookings Institution).
- Nosheen, Rashid, A.(2020) Financial soundness of single versus dual banking system: explaining the role of Islamic banks. *Port Econ J* (2020). <https://doi.org/10.1007/s10258-019-00171-2>
- Ramirez Miguel D. (2007), Boom-Bust Cycles and financial liberalization, *Eastern Economic Journal*, Vol 33. No 4 (fall, 2007), pp 569-571.
- Shaw, Edward, (1973). *Financial Deepening in Economic Development*, (New York: Oxford University Press).

THE OVER CONCENTRATION OF *TAWARRUQ* CONTRACT IN ISLAMIC HOME FINANCING IN MALAYSIA

Norhazlina Ibrahim^{*a} & Safeza Mohd Sopian^b

Faculty of Economics and Muamalat Universiti Sains Islam Malaysia

Abstract

The evolution of Islamic financial products from simple to complicated structures in Malaysia, is evidenced by the growth of Islamic finance in the country. Many of these products are being accused to replicate and mimicking the conventional products, thus alleged of not living to the spirit of Shariah. Many Islamic Banks favoured debt-based products, which mimicking conventional products rather than offering profit and loss sharing products. There are also concerns that the majority of the products offered by the Islamic banks are concentrated on the *Tawarruq* products. Many concerns from the regulator the usage of this product. The purpose of this study is to investigate the usage of *Tawarruq* contract on the home financing products offered by all Islamic Banks in Malaysia in 2020. Further investigation was done to study the evolution of the home financing for each bank. The methodology used in this study is through content analysis (website, brochures, Product Disclosure Sheet (PDS), and annual report). The finding shows that around 63% of the Islamic banks offer *Tawarruq* for home financing in 2020. The study also revealed that many banks prefers to use *Tawarruq* in the recent years.

Keywords: Islamic Finance, Islamic Banks, *Tawarruq*

1.0 INTRODUCTION

Since the inception of Islamic finance more than 30 years ago, Islamic finance has comfortably set its footing in many Muslim countries and evidenced by tremendous growth especially in Malaysia. The emergence of Islamic banking and finance products that carries significant uniqueness as to compare with conventional banking products has enticed Malaysian to opt for Islamic banking and finance services offered by Islamic banks which includes non-Muslim. This trend has helped to further boost the growth of Islamic banking and finance (IBF) in Malaysia.

In Malaysia, the banking system are operating in dual banking environment, which both systems are operating in parallel. Both conventional and Islamic banks perform the same essential functions nonetheless the modus operandi is different. For Islamic bank, not only they are bound by the same banking regulation as conventional banks, they also required to obey Islamic principles. As they are founded by religion of Islam, their accountability towards society are higher especially on moral and social values. Naturally these banks need to find equilibrium between Shariah requirements and profit making or they are unable to survive in the industry (Aris et al., 2013).

Conventional banks operate through interest or *riba*, however interest (*riba*) is clearly prohibited in the Islamic banks' operation. According to Shariah, any additional money raised from lending or borrowing is *riba* (interest) based on interest as their income but since interest are prohibited, Islamic banks have to use other means to sustain their operations. This is aligned with the command of Allah stated in Quran that:

Those who devour usury [Riba] will not stand except as stand one whom the Evil one by his touch Hath driven to madness. That is because they say: "Trade is like usury," but Allah hath permitted trade and forbidden usury. Those who after receiving direction from their Lord, desist, shall be pardoned for the past; their case is for Allah (to judge), but those who repeat (The offense) are companions of the Fire: They will abide therein (forever). (2:275)

Thus, following this prohibition, any transactions must involve trading such as *Mudharabah*, *Murabahah*, *Musharakah*, *Ijarah*, *Istisna'* and *Tawarruq* to replace income from interest as in conventional practices. Similar to their counter party, these Islamic banks offer a comprehensive and broad range of Islamic financial products and services ranging from deposit products (savings, current and investment) to financing products (home financing, personal financing, vehicle financing, trade financing).

Islamic Financial Services Board (IFSB) (2010) highlighted that Malaysia has gone through 4 successful important phases in the development of Islamic Banking and Finance. The first phase was started with the introduction to the basic contracts such as *Wadiyah* and *Mudarabah* for deposit products and *Bai Bithaman Ajil (BBA)* for financing

products. In 1993, second phase start to roll where corporate, Islamic money and capital market instruments begin to emerge in the industry such as *Murabahah* working capital. The third phase in 1999, many hybrids products start to surface such as *al-Ijarah Thumma al-Bai* (AITAB), *Ijarah* fixed financing and Islamic credit cards. Lastly, in the final phase the emergence of more complex and intense type of products start to capture the financial market such as *Musharakah Mutanaqisah* (MM) and *Mudarah* financing as well as derivatives and hedging products (Bahari, 2009).

Home financing today has played a vital role in banking and contributing a great amount of percentage in the growth of the economy not only in Malaysia but also elsewhere across the international borders. Jalil et al. (2010) mentioned that in the initial stage, Malaysia home financing was monopolized by the conventional banks which started in year 1830. An economic report published by Ministry of Finance (MOF) for year 2007/2008 showed that home financing is the largest financing type in Malaysia at that time delivering many projects namely MyBeautiful New Home (MyBNHome), Program Perumahan Rakyat (PPR), Rumah Mesra Rakyat (RMR) and Perumahan Rakyat 1Malaysia (PR1M) (Laporan Ekonomi Malaysia, 2017/2018). Jalil et al. (2010) opined that home financing is the type of financing that received the biggest selection by customers due to the economic demand and needs in Malaysia. The evidenced of growth in Islamic banking and finance in Malaysia give no exception to Islamic home financing. According to Jalil and Naharu (2020), the increase of 8.3%, in Islamic banking assets from RM771.8 billion in year 2018 to RM835.2 billion in 2019, was mainly contributed by home financing estimated around RM184.4 billion.

In Malaysia, Islamic banks offer home financing products ranging from *Bay` Bithaman Ajil* (BBA), *Musharakah Mutanaqisah*, *Tawarruq*, *Ijarah* and *Istisna`*. Figure 1 shows the timeline and evolution of Islamic Home Financing in Malaysia.



Figure 1: The evolution of Islamic Home Financing in Malaysia

Bay` Bithaman Ajil (BBA) is the first Islamic home financing products, introduced by Bank Islam Malaysia Berhad (BIMB) in late 1984. BBA is defined as deferred payment, through instalments, on the sale of an asset with a pre-agreed price, payment method and profit. The product become quite popular amongst Islamic banks in Malaysia (BIMB, 2012). Many argued that BBA is presenting a mode of payment rather than contract where the payment is deferred in the future through installment or full payment (Engku Rabiah Adawiah, 2012; INCEIF, 2007; Zaharuddin, 2010). Besides being widely used in Malaysian Islamic banks, BBA also received many critiques from the scholars highlighting on its Shariah and operational issues.

Rosly (2001, 2005); Meera & Larbani (2009) agreed that BBA has some operational and Shariah non-compliant issues which leading to the opening of the back door for *riba*. Undertaking trading as the alternative to *riba* transaction, requires the seller i.e. the bank to hold ownership of the goods and all liabilities comes from it. However, BBA has not evidenced any ownership being held and absence in risk taking thus it violates the very essence of Shariah principles of *al-ghorm bil ghom* (no reward without risk) and *al-kharaj bil daman* (profits comes with liability). The absence of risk taking in BBA does not reflects the requirement of *al-bay* (trading) as what has been dictated by Allah S.W.T in the Quran. Accordingly, Rosly (2005) mentioned that Ibn al-‘Arabi (d.543H/1148), opined the element of *‘iwad* (counter value), namely effort, liability and risk must be incorporated for lawful sale. Any additional amount without *‘iwad* is tantamount to *riba*.

Resulting to numerous criticisms, several alternatives of home financing are being introduced in the market as a replacement to BBA. One of them is *Musharakah Mutanaqisah* (MM). MM is technically very different from BBA where it is based on diminishing partnership concept. *Musharakah Mutanaqisah* (MM), also known as *Diminishing Musharakah/Partnership* is a partnership contract between two parties where one party’s installments will gradually increase his share in the property till the whole ownership (Subky, 2017; Bank Negara, 2010).

As an alternative to BBA contract, Kuwait Finance House Malaysia Berhad (KFHMB) launched Malaysia’s first equity-based house financing facility under the *Musharakah Mutanaqisah* concept in 2006. The Shariah Advisory Council (SAC) of Bank Negara Malaysia, resolved that the product of MM is permissible in its 56th meeting held on 5th February 2006 (Bank Negara Malaysia, 2010).

KFHMB were commended for offering equity based financing, rather than relying too much on debt-based financing. Many postulated that a country's finance that is built on debt-based financing, will not be able to maintain efficiency, stability and growth in the long run (Siddiqi, 1983, 2001; Ahmad, 1984, Smolo and Hassan, 2011; Rosly and Bakar, 2003). Many Islamic banks followed KFHMBS switched to *Musharakah Mutanaqisah*, but then many of them discontinued or froze the product and replaced it with more convenient products in terms of maintenance and legal support such as *Tawarruq*, *Ijarah Muntahiyah bit Tamlik (IMBT)* and *Istisna'*. According to Subky (2017) the related banks are Ambank Islamic, Asian Finance Bank, Bank Muamalat, KFHMBS, Maybank Islamic and OCBC Al Amin.

Even though it looks promising theoretically but in practice, there are many implementation hurdles, associated with MM. The issues of MM could be classified under 2 major categories; operating and legal. Under operating, the documentations are lengthy, MM have long list of documentation as compared with other products, thus make it more costly (Subky, 2017). The complicated of MM contracts accounted to shortage of legal advisors and lawyer who could prepare the MM documents (Shahwan et al., 2013). Even though some argue on the main advantage of MM is the flexibility and revisable of the rental rates but the rates are largely influenced by location, tax regulations, as well as wear and tear (Meera and Abdul Razak, 2005). Additionally, there are also issues such as defaults, termination of contracts and even redemption (Meera and Abdul Razak, 2009).

As a result of the complication in MM, another players in town such as *Tawarruq*, *Ijarah Muntahia Bil Tamlik (AIMAT)* and *Istisna'* starts gaining its popularity around 2013. However, in the case of *Tawarruq*, also known as *Commodity Murabahah (CM)*, the permissibility of this product is being questioned. It has recently become popular in the local Islamic banking industry for liquidity management instruments, or cash liquidity purposes. It can be considered as an alternative instrument to BBA (which has element of *bay' al- 'inah*), which was adopted in Malaysia a few years back. The arrangement of getting liquidity is more or less has similar style as *bay' inah*, missing the elements of genuine transactions. Some said the overconcentration of these attention that most of the products offered by Islamic banks are in *Tawarruq* (Ali, 2017). According to him, the popularity of *Tawarruq* started when BNM issued the circular¹⁴⁹ on *bay' inah* in 2012 to exclude "mandatory buy back" provision in the contract. With the less popularity of MM and BBA, many banks turn to *Tawarruq* in their financing portfolio (Ali, 2017). Basically, many banks prefer *Tawarruq* based on their less risky nature towards the bank's position in the transaction.

The AAOIFI, FAS 30, *Tawarruq* should only be employed as a last resort when an institution faces a liquidity shortage that could harm its sustainability. It should not be used as a mode of investment or financing for the purpose of profit making. Secondly, the overwhelming use of *Tawarruq* does not substantially add to the IFI value proposition and economic growth due to debt nature inherent in the concept.

However, the widespread usage of this product has raised uneasiness by Muslim economists and Shariah scholars. This strengthen the view of proponents that many of Islamic banks products are just a mere substitute rather than alternative. Some said that the contract has controversial nature for being non-compliant to the Shariah as the study done by Ahmed et.al (2012), they found that *Tawarruq* and *Bai al-Inah* at some point have the element of *shubahah* in them.

Whilst other choose *Tawarruq*, others opt for *AIMAT* and *Istisna'*. However these 2 products are not short of flaws and shortcomings. With all the criticism, it would be interesting to investigate the current issues surrounding Islamic home financing in Malaysia. These lead to these research questions:

to investigate the home financing products offered by Islamic Banks in 2020.

to examine the composition the home financing products for each bank from 2015 to 2019.

This study claims two major contributions out of its investigation. Firstly, exploring the issues of home financing will give a general overview of the recent development in Islamic home financing and its surrounding issues, which is expected to indirectly help policymakers and bankers to design a better policy in dealing with Islamic home financing and its issues.

Secondly, the review of literature suggests the common norm of research studies to mainly focus on the survey and interviews but rarely look into the composition of these home financing in details from annual report. It is hoped

¹⁴⁹ <https://islamicbankers.files.wordpress.com/2013/12/20121219-implementation-of-shariah-advisory-council-of-bank-negara-malysias-resolution-on-bai-inah.pdf>

that the analysis on home financing figure in the study able to shape a better Islamic home financing framework and system in Malaysia.

The structural remainder of this paper is organised as follows: Section 2 and 3 provide details discussion on the structure and process of all Islamic Home Financing offered by the banks alongside with the literature review on Islamic home financing. Section 4 elaborates on the study's research methodology and the data collection method. Section 5 depicts the analytical part of the study, and Section 6, which is also the last, provides the study's concluding remarks.

2.0 ISLAMIC HOME FINANCING

There are wide ranges of Islamic home financing offered by the Islamic banks in Malaysia, namely, *BBA*, *Musharakah*, *Tawarruq*, *Ijarah* and *Istisna'*. These products could categorised into 3 main categorization, namely debt-based financing, equity based financing and leasing.

2.1 BBA

BBA fall under debt based financing, and often being accused mimicking the conventional products. In Malaysian Islamic bank's practice, BBA apply *Murabahah*.

2.2 MM

Musharakah Mutanaqisah (MM) is a diminishing partnership concept that comprises contracts which are *Musharakah* (partnership) and *Ijarah* (renting). MM which are often been categorized equity based financing.

Meera and Razak (2005) has done quite a comprehensive review on how the MM works principally and technically. In summary, customer and bank will enter into a partnership contract under joint ownership agreement where both customer and bank will co-own the property. This co-ownership agreement entitled the customer 10% ownership of the property which is presented in terms of the down payment made by the customer for the property while the bank has the remaining 90% of the property ownership. The portion of co-ownership will gradually be increased for the customer and decreased for the bank until the property is fully owned by the customer. At the same time, the rental contract in the forms of *Ijarah* contract will take effect on the 90% ownership by the bank i.e. rental will be charged to the customer through out the financing period. And this rental amount and tenor is representing the share ratio of the property ownership until the ownership is fully transferred to the customer.

2.3 Tawarruq

According to Shariah Standard on Mudarabah issued by Bank Negara Malaysia (Refer Section 9.1).

"A tawarruq consists of two sale and purchase contracts. The first involves the sale of an asset by a seller to a purchaser on a deferred basis. Subsequently, the purchaser of the first sale will sell the same asset to a third party on a cash and spot basis".

In essence, *tawarruq* is a hybrid concept that consists of a credit and cash sale, which is similar to the concept of *'inah*. The credit sale normally contains a profit margin, which is commonly executed under the basis of the *murabahah* concept. *Murabahah* is a cost plus sale, which refers to the sale and purchase of goods at a price with the profit margin agreed by both the seller and the buyer. The common term used in the market today to denote *tawarruq* is commodity *murabahah* transaction. In Malaysia, the common commodity used is Crude Palm Oil (CPO) made available by Bursa Suq al-Sila', whereas metals are normally used in the London Metal Exchange.

2.4 Ijarah

Ijarah Mausufah Fi Zimmah means an *ijarah* contract which is executed for an asset undertaken by the lessor (Bank) to be delivered to the lessee according to accurate specifications, even if the asset is not owned by the lessor. During the period that the leased asset/property is under construction, the lessor may ask the lessee (Customer) to pay a certain portion of pre agreed lease rental as a forward lease. The forward lease rental payment will be considered as a debt to the lessor until the delivery of the leased asset to the lessee. The Customer undertakes to purchase the asset/property upon the end of the lease period or full payment the asset/property price or in the event of default, subject to agreed terms and conditions. Ownership will be transferred to customer at the end of leasing period (or upon full settlement) by way of 'sale'.

3.0 LITERATURE REVIEW

Studies on Islamic home financing usually looking at the perception of the customers in adopting Islamic home financing products.

In Malaysia context, being a multi-racial country, several studies such as Shah (2012) and Amin et al. (2014) agreed that the choice of selecting Islamic home financing among Malaysian depends on several important factors such as marital status, ethnic, occupation, religion, attitude and perceived behavior are among the highest influential factors as to compare to gender, academic qualification and monthly income. Thus, it is crucial that Islamic banks in Malaysia to have various types of Islamic home financing products that are competitive enough to be offered to the customers in order to compete and received equal share together with their conventional counterpart.

Others look at a specific review on certain product of home financing to discuss its advantages and drawbacks.

Aris et al. (2013), in their study disclosed the home financing products by 6 Islamic banks but only confined to BBA and MM only. They argued that even a single contract could have several variant, in term of rate, tenure and coverage, consequently creating a complex and complicated environment for the customer and greater monitoring tasks for regulators. Nonetheless, they admitted that varieties implied more options for the customers to choose from.

All 16 Islamic banks in Malaysia are equally offering similar types of home financing products. Various types of Islamic home financing products have been extended to the customers such as BBA financing, MM, *Istisna'*, *Murabahah*, *Ijarah Mausufah Fi Zimmah*, *Ijarah Muntahiyah*, *Al-Ijarah Muntahiyah Bi Tamlik* and *Tawarruq*. Studied done by Shahwan et.al (2013) shows that out of 23 home financing products offered by the Malaysian Islamic banks, 65.23% using BBA concept, 21.75% using MM and 4.34% using *Tawarruq*, *Istisna'* and *Murabahah*. From the statistic, obviously BBA received the highest usage in Malaysian Islamic banks as reported by Bank Negara Malaysia where BBA is the main type of contract endorsed amounting to 67,672.9 million Ringgit Malaysia followed by *Al-Ijarah Thumma Al-Bai'* (AITAB) (BNM, 2011). Even though, BBA received critiques from many scholars on its operational and Shariah issues, its technical simplicity has made it the main choice by the Islamic banks in fulfilling the needs for Malaysian home-owner despite its rejection in most of Arab countries (Shahwan et.al).

MM partnership is another famous type of contract for Islamic home financing in Malaysia. According to Haneef et.al (2011), the introduction of MM into the market was first approved in 1991 during a workshop that was co-organized by Islamic Research and Training Institute (IRTI) and the Sudanese Estates Bank held in Khartoum. Whereas in Malaysia BNM and Shariah Advisory Council (SAC) conquered MM on 5th February 2006 (BNM, 2010).

On the overall studies done in Islamic Home Financing, less studies look at the composition of the Home Financing in details.

4.0 METHODOLOGY

As to answer the research questions, the study adopts several steps. Firstly, as to gather information on the current home financing products, content analysis is applied. The data of are gathered through banks' websites and brochures from the bank. In some instances, the Product Disclosure Sheet (PDS) and annual report to clarify any unclear information from the banks' websites.

Table 1: Data Collection and Methodology

Research Questions	Data Collection	Method
to explore the current home financing products offered by Islamic Banks in 2020	Website, PDS, annual report	Content analysis
to examine the composition of the home financing products for each bank from 2015 to 2019	Annual report	Descriptive analysis and graphical

The second step is to collect the data of the products offered by all Islamic Banks in Malaysia. As of January 2020 there are 16 Islamic Banks in Malaysia, under BNM¹⁵⁰ purview comprises of 11 local and 5 foreign banks (Refer to Table 2).

¹⁵⁰ Accessed <http://www.bnm.gov.my/index.php?ch=li&cat=islamic&type=IB&fund=0&cu=0> on 4th Mac 2020.

5.0 ANALYSIS AND FINDINGS

Based on Table 1, many of the banks offer Tawarruq product as compared with other products.

Table 2: Home Financing products offered by Islamic Banks in Malaysia in 2020

No	Islamic Banks	Ownership	Home Financing				
			BBA	Tawarruq	MM	Ijarah	Istisna'
1	Affin Islamic Bank Bhd	Local		x	x	(s)	
2	Al Rajhi Banking & Investment Corporation (Malaysia) Bhd	Foreign		x			
3	Alliance Islamic Bank Bhd	Local	x				
4	AmBank Islamic Berhad	Local		x			
5	Bank Islam Malaysia Bhd	Local		x			
6	Bank Muamalat Malaysia Bhd	Local		x			
7	CIMB Islamic Bank Bhd	Local		x			
8	HSBC Amanah Malaysia Bhd	Foreign			x	(s)	
9	Hong Leong Islamic Bank Bhd	Local		x			
10	Kuwait Finance House (Malaysia) Bhd	Foreign				x	
11	MBSB Bank Bhd	Local		x			
12	Maybank Islamic Bhd	Local		x			
13	OCBC Al-Amin Bank Bhd	Foreign				x	
14	Public Islamic Bank Bhd	Local			x	(s)	
15	RHB Islamic Bank Bhd	Local		x	x	(s)	
16	Standard Chartered Saadiq Bhd	Foreign			x	(s)	
	Percentage		6.25%	62.5%	31.25%	12.5%	-

Note: BBA is Bai Bithaman Ajil, MM is Musharakah Mutanaqisah/Diminishing Partnership, Tawarruq (Commodity Murabahah), Ijarah (AIMAT or Ijarah Mausufah fi Zimmah)

S denotes the supporting contracts, appear in the PDS

It seems that most of the banks are offering *Tawarruq* for Home financing in 2020. Based on their websites, out of 16 banks 10 offers *Tawarruq*. There are few banks for example disclose in their website as *Murabahah*, however after close examination on their PDS, the product is actually Commodity *Murabahah* or *Tawarruq*.

Clearly from Table 1, a total of 10 out of 16 banks or 62.5% choose Tawarruq, followed by MM (31.2%), Ijarah (12.5%) and BBA by 6.25%. Based on the findings, in 2020 none of the banks offer Istisna' home financing.

It seems that more banks are adopting Tawarruq because based on Hanuddin Amin (2018), as of January 2018, only 6 out of 16 Islamic banks are offering their mortgages on the basis of Tawarruq home financing.

However, it would be interesting to know the amount of this *Tawarruq* Financing in value to see the impact. Further findings are revealed from the annual report from 2015 to 2019 of these banks.

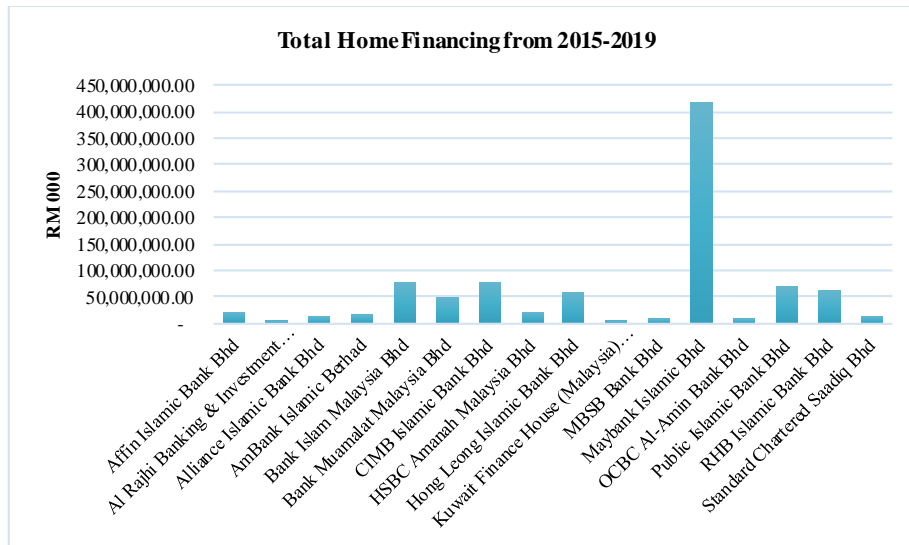

Figure 2: Total Home Financing

From the data, Maybank Islamic lead the pack by quite extensively more than 400 billion (45%), 5 times more than Bank Islam around 79 billion, which come second providing home financing.

Table 3: Total Financing for each bank

Banks	Financing (RM 000)	Percentage
Affin Islamic Bank Bhd	23,138,717.00	2%
Al Rajhi Banking & Investment Corporation (Malaysia) Bhd	5,315,263.00	1%
Alliance Islamic Bank Bhd	12,956,100.00	1%
AmBank Islamic Berhad	18,072,167.00	2%
Bank Islam Malaysia Bhd	79,519,802.00	9%
Bank Muamalat Malaysia Bhd	51,932,846.00	6%
CIMB Islamic Bank Bhd	77,497,623.00	8%
HSBC Amanah Malaysia Bhd	21,500,709.00	2%
Hong Leong Islamic Bank Bhd	57,987,782.00	6%
Kuwait Finance House (Malaysia) Bhd	4,538,312.00	0%
MBSB Bank Bhd	9,338,160.00	1%
Maybank Islamic Bhd	415,489,406.00	45%
OCBC Al-Amin Bank Bhd	9,804,503.00	1%
Public Islamic Bank Bhd	69,501,311.00	7%
RHB Islamic Bank Bhd	61,516,722.00	7%
Standard Chartered Saadiq Bhd	14,173,281.00	2%
TOTAL	932,282,704.00	100%

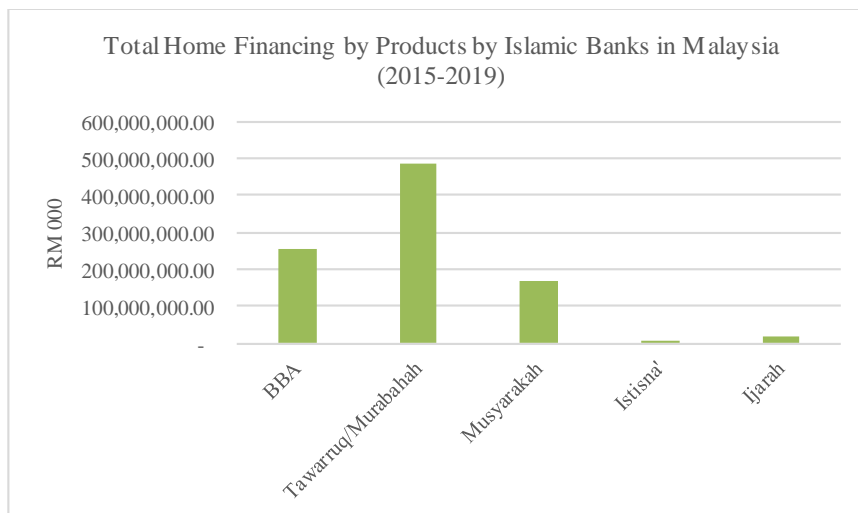
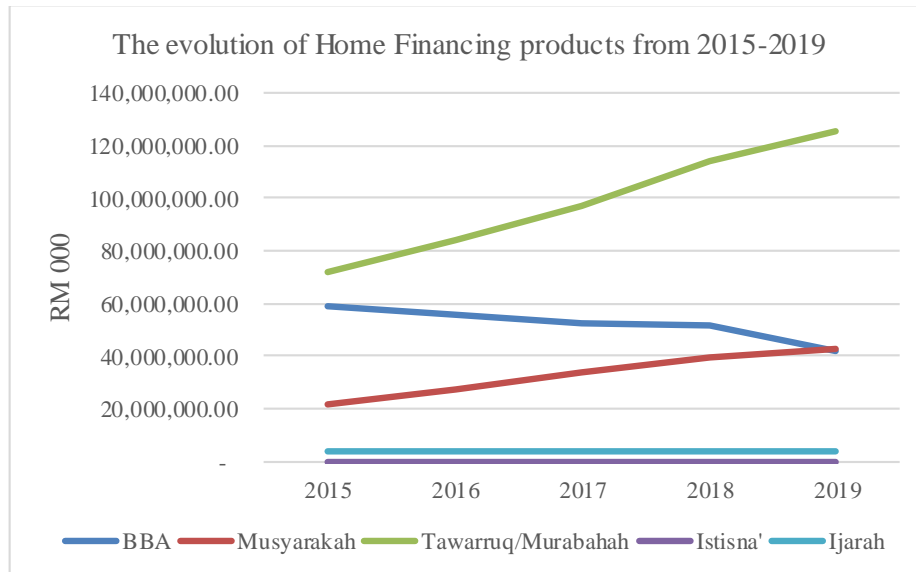

Figure 3: Total Home Financing by products

Table 4: Total Financing by Products

Product	Financing (RM 000)	Percentage
BBA	256,684,858.00	28%
Tawarruq/Murabahah	488,035,057.00	52%
Musyarakah	166,530,357.00	18%
Istisna'	371,764.00	0%
Ijarah	20,660,668.00	2%
Total	932,282,704.00	100%

It could be noted in the annual report Maybank for example classify the Commodity Murabahah as *Murabahah* categorization. Is the amount of *Murabahah* home financing is mainly coming from Maybank Islamic. However, if we look at the PDS of Maybank Islamic, the term *Murabahah* is referring to Commodity Murabahah which is Tawarruq.

**Figure 4: The evolution of Home Financing from 2015-2019**

5.1 Why Tawarruq becomes popular?

Bank Negara Malaysia (2016) reported that *Tawarruq* financing grew over 34 percent that has been largely spurred by the commodity trading operation of Bursa Suq Al-Sila, which has reduced costs and risks associated with *tawarruq*-based transactions including Islamic home financing.

Bank Islam Malaysia Berhad (BIMB) indicates that its *tawarruq* home financing is well-performed. Evidently, on 31st December 2014, the bank managed to reap a financing value of RM3.9 billion and increased to RM9.5 billion on 31st December 2016 (Bank Islam, 2014; 2016).

Nonetheless, the development of banking *tawarruq* shows the concerns and recognition by some of the jurists globally of the need to find alternatives for solving the problem of liquidity shortage faced by Muslims around the world (Dusuki, 2007). While some scholars (e.g. Mohamad and Rahman, 2014) commented that *tawarruq* could be the most suitable concept for banking products that require cash-based dealing.

In a study of why Islamic financial institutions (IFIs) are reluctant to adopt *Istisna* in Malaysia, Hasmawati and Mohamad (2019) concluded the following; first, a construction project has high levels of uncertainty and risk which may affect completion time and quality; second, other instruments such as BBA and MM are easier to implement than *Istisna*. In other words, Malaysian IFIs consider financing construction projects to be a risky investment. This suggests that an Islamic bank is more risk-averse than its conventional counterpart (Dieng, 2019).

The products offering for each bank

<p style="text-align: center;">Affin Islamic Bank Bhd</p> <table border="1"> <caption>Affin Islamic Bank Bhd Data (Approximate)</caption> <thead> <tr> <th>Year</th> <th>BBA</th> <th>MM</th> </tr> </thead> <tbody> <tr> <td>2015</td> <td>~1,000,000</td> <td>~1,000,000</td> </tr> <tr> <td>2016</td> <td>~1,000,000</td> <td>~2,000,000</td> </tr> <tr> <td>2017</td> <td>~1,000,000</td> <td>~3,500,000</td> </tr> <tr> <td>2018</td> <td>~1,000,000</td> <td>~5,500,000</td> </tr> <tr> <td>2019</td> <td>~1,000,000</td> <td>~6,500,000</td> </tr> </tbody> </table>	Year	BBA	MM	2015	~1,000,000	~1,000,000	2016	~1,000,000	~2,000,000	2017	~1,000,000	~3,500,000	2018	~1,000,000	~5,500,000	2019	~1,000,000	~6,500,000	<p>MM main Reduce BBA Starting to offer Tawarruq</p>
Year	BBA	MM																	
2015	~1,000,000	~1,000,000																	
2016	~1,000,000	~2,000,000																	
2017	~1,000,000	~3,500,000																	
2018	~1,000,000	~5,500,000																	
2019	~1,000,000	~6,500,000																	
<p style="text-align: center;">Al Rajhi Banking & Investment Corporation (Malaysia) Bhd</p> <table border="1"> <caption>Al Rajhi Banking & Investment Corporation (Malaysia) Bhd Data (Approximate)</caption> <thead> <tr> <th>Year</th> <th>BBA</th> <th>MM</th> </tr> </thead> <tbody> <tr> <td>2015</td> <td>~1,000,000</td> <td>~1,200,000</td> </tr> <tr> <td>2016</td> <td>~1,000,000</td> <td>~1,100,000</td> </tr> <tr> <td>2017</td> <td>~1,000,000</td> <td>~1,000,000</td> </tr> <tr> <td>2018</td> <td>~1,000,000</td> <td>~950,000</td> </tr> <tr> <td>2019</td> <td>~1,000,000</td> <td>~900,000</td> </tr> </tbody> </table>	Year	BBA	MM	2015	~1,000,000	~1,200,000	2016	~1,000,000	~1,100,000	2017	~1,000,000	~1,000,000	2018	~1,000,000	~950,000	2019	~1,000,000	~900,000	<p>BBA main, but at the declining rate</p>
Year	BBA	MM																	
2015	~1,000,000	~1,200,000																	
2016	~1,000,000	~1,100,000																	
2017	~1,000,000	~1,000,000																	
2018	~1,000,000	~950,000																	
2019	~1,000,000	~900,000																	
<p style="text-align: center;">Alliance Islamic Bank Bhd</p> <table border="1"> <caption>Alliance Islamic Bank Bhd Data (Approximate)</caption> <thead> <tr> <th>Year</th> <th>BBA</th> <th>MM</th> </tr> </thead> <tbody> <tr> <td>2015</td> <td>~2,500,000</td> <td>~2,500,000</td> </tr> <tr> <td>2016</td> <td>~2,500,000</td> <td>~2,600,000</td> </tr> <tr> <td>2017</td> <td>~2,500,000</td> <td>~2,700,000</td> </tr> <tr> <td>2018</td> <td>~2,500,000</td> <td>~2,800,000</td> </tr> <tr> <td>2019</td> <td>~2,500,000</td> <td>~3,000,000</td> </tr> </tbody> </table>	Year	BBA	MM	2015	~2,500,000	~2,500,000	2016	~2,500,000	~2,600,000	2017	~2,500,000	~2,700,000	2018	~2,500,000	~2,800,000	2019	~2,500,000	~3,000,000	<p>BBA incline to 2017 but then increase</p>
Year	BBA	MM																	
2015	~2,500,000	~2,500,000																	
2016	~2,500,000	~2,600,000																	
2017	~2,500,000	~2,700,000																	
2018	~2,500,000	~2,800,000																	
2019	~2,500,000	~3,000,000																	
<p style="text-align: center;">AmBank Islamic Berhad</p> <table border="1"> <caption>AmBank Islamic Berhad Data (Approximate)</caption> <thead> <tr> <th>Year</th> <th>BBA</th> <th>MM</th> </tr> </thead> <tbody> <tr> <td>2015</td> <td>~3,000,000</td> <td>~1,500,000</td> </tr> <tr> <td>2016</td> <td>~3,000,000</td> <td>~2,000,000</td> </tr> <tr> <td>2017</td> <td>~3,000,000</td> <td>~2,500,000</td> </tr> <tr> <td>2018</td> <td>~3,000,000</td> <td>~3,000,000</td> </tr> <tr> <td>2019</td> <td>~3,000,000</td> <td>~3,200,000</td> </tr> </tbody> </table>	Year	BBA	MM	2015	~3,000,000	~1,500,000	2016	~3,000,000	~2,000,000	2017	~3,000,000	~2,500,000	2018	~3,000,000	~3,000,000	2019	~3,000,000	~3,200,000	<p>BBA increasing, but after 2019, declining Tawarruq increasing</p>
Year	BBA	MM																	
2015	~3,000,000	~1,500,000																	
2016	~3,000,000	~2,000,000																	
2017	~3,000,000	~2,500,000																	
2018	~3,000,000	~3,000,000																	
2019	~3,000,000	~3,200,000																	

<p style="text-align: center;">Bank Islam Malaysia Bhd</p>	<p>Tawarruq increasing BBA declining Istisna' only small portion</p>
<p style="text-align: center;">Bank Muamalat Malaysia Bhd</p>	<p>Tawarruq increasing BBA declining However sudden drop in 2019</p>
<p style="text-align: center;">CIMB Islamic Bank Bhd</p>	<p>Tawarruq increasing BBA declining Ijarah declining</p>
<p style="text-align: center;">HSBC Amanah Malaysia Bhd</p>	<p>MM with no trend</p>

<p style="text-align: center;">Hong Leong Islamic Bank Bhd</p> <p>12,000,000.00 10,000,000.00 8,000,000.00 6,000,000.00 4,000,000.00 2,000,000.00 -</p> <p style="text-align: center;">2015 2016 2017 2018 2019</p>	<p>Tawarruq increasing BBA declining</p>
<p style="text-align: center;">Kuwait Finance House (Malaysia) Bhd</p> <p>1,200,000.00 1,000,000.00 800,000.00 600,000.00 400,000.00 200,000.00 -</p> <p style="text-align: center;">2015 2016 2017 2018 2019</p>	<p>Ijarah increasing MM stopped/discontinued</p>
<p style="text-align: center;">MBSB Bank Bhd</p> <p>3,500,000 3,000,000 2,500,000 2,000,000 1,500,000 1,000,000 500,000 0</p> <p style="text-align: center;">2015 2016 2017 2018 2019</p>	<p>Tawarruq increasing BBA declining</p>
<p style="text-align: center;">Maybank Islamic Bhd</p> <p>80,000,000.00 70,000,000.00 60,000,000.00 50,000,000.00 40,000,000.00 30,000,000.00 20,000,000.00 10,000,000.00 -</p> <p style="text-align: center;">2015 2016 2017 2018 2019</p>	<p>Tawarruq increasing BBA declining MM declining</p>

<p style="text-align: center;">OCBC Al-Amin Bank Bhd</p>	<p>Ijarah no trend MM declining</p>
<p style="text-align: center;">Public Islamic Bank Bhd</p>	<p>MM increasing BBA declining</p>
<p style="text-align: center;">RHB Islamic Bank Bhd</p>	<p>MM increasing BBA declining Tawarruq increasing</p>
<p style="text-align: center;">Standard Chartered Saadiq Bhd</p>	<p>MM declining BBA declining</p>

6.0 CONCLUSION

Based on the study done, it is clearly that the *Tawarruq* is the most popular product in Islamic Home Financing, since more than 60% of the banks use them. The trends also showed that those banks that use *Tawarruq*, the proportion are keep on increasing. Thus, the question whether the Islamic financial products are actually an alternative to the industry are also deemed futile as they are similar to the conventional, debt based financing.

Nonetheless, the issues arises as to no better alternative products that could replace *tawarruq*. What the industry really need is the constructive criticism as to be able to give a proactive solution to the current problem in the industry. Even though *Tawarruq* are not really well accepted by some, but at this point there are no better alternative product better than can replace *tawarruq*.

REFERENCES

- Ahmed, E. R., Yahaya, S & Harashid, M. (2012). Shubuhath on Matter of Bai' alinah and Tawarruq. *International Journal of Business and Technopreneurship*, 2(1), 85-101.
- Ahmad, E. F.; Shihama, M.; Mohamad Tarmizi, N. A.; Jibril, S. M.; Djama, S. I. and Muneza, A. (2017), "Tawarruq as a Product for Financing within the Islamic Banking System: A Case Study of Malaysian Islamic Banking System", *International Journal of Management and Applied Research*, Vol. 4, No. 1, pp. 31-43. <https://doi.org/10.18646/2056.41.17-004>
- Ali, M. (2017). Retrieved from <https://www.nst.com.my/news/2017/03/225846/tawarruq-new-kid-islamic-banking>
- Amin, H., Rahim Abdul Rahman, A. & Abdul Razak, D. (2014). Consumer Acceptance of Islamic Home Financing. *International Journal of Housing Markets and Analysis*, 7(3), 307-332. <http://doi.org/10.1108/IJHMA-12-2012-0063>
- Aris, N. A., Othman, R., Azli, R. M., Sahri, M., Razak, D. A., & Rahman, Z. A. (2013). Islamic banking products: Regulations, issues and challenges. *Journal of Applied Business Research*, 29(4), 1145-1156.
- Bank Negara Malaysia (2010). Shariah Resolutions in Islamic Finance. Malaysia Deposit Insurance Corporation, [Online] available from: http://www.bnm.gov.my/microsite/fs/sac/shariah_resolutions_2nd_edition_ (accessed on 20 July 2016).
- Bahari, Z. B. (2009). The Changes of Product Structure in Islamic Banking: Case Study of Malaysia. Paper presented at the Two-Day Conference on Islamic Perspectives on Management and Finance, United Kingdom organized by School of Management, Leicester University, 2-3 July 2009. <https://core.ac.uk/download/pdf/11940593.pdf>
- Bank Negara Malaysia (BNM). (2011). Buletin Perangkaan Bulanan (Monthly Statistical Bulletin). Bank Negara Malaysia (BNM). Kuala Lumpur.
- Bank Negara Malaysia (BNM). (2010). Shariah Resolutions in Islamic Finance. Bank Negara Malaysia (BNM). Kuala Lumpur, Malaysia
- Bouheraoua, S. I. (2013), "Tawarruq in the banking system: a critical analytical study of juristic views on the topic", presented in: 19th Session OIC Fiqh Academy, United Arab Emirates, [Online] available from: <http://www.iefpedia.com/english/wp-content/uploads/2009/10/Tawarruq-In-The-Banking-System-A-Critical-Analytical-Study-Of-Juristic-Views-On-The-Topic.pdf>
- BIMB. (2012). Application of Shariah Contracts In Islamic Banking Products And Services. In B. I. M. B. (BIMB) (Ed.). <http://www.bankislam.com.my/home/assets/uploads/BIMB-Shariah-Book-240613-FA.pdf>
- Devlin, J.F. (2002). An Analysis of Choice Criteria in the Home Loans Market. *International Journal of Bank Marketing*, 20(5), 212-226.
- Engku Rabiah Adawiah, E. A. (2012). Structuring Sale Based Products in Islamic Banking and Finance. Paper presented at the Structuring Islamic Financial Products, Kuala Lumpur, Malaysia.
- Haneef, R., Kunhibava, S., & Smolo, E. (2011). Musharakah Mutanaqisah And Legal Issues: Case Study of Malaysia. *ISRA International Journal of Islamic Finance*, 3 (June): 93-122
- INCEIF. (2007). The Application of Bay' Bithaman Ajil (BBA). INCEIF CIFP Module on Applied Shariah In Financial Transactions. INCEIF Kuala Lumpur, Malaysia
- Islamic Financial Services Board (IFSB). (2010). Islamic Finance and Global Financial Stability (pp. 27). IFSB, IR TI, IDB. Jeddah
- Jalil, M.I.A, Remali, Y. & Roslinah, M. (2010). Selection Factors of Customer towards Islamic and Conventional Home Financing: A Case Study in Johor, Malaysia. MPRA Paper. <https://mpr.ub.uni-muenchen.de/68433/>
- Jalil and Naharul (2020). Retrieved from <https://themalaysianreserve.com/2020/02/03/islamic-banking-continues-to-expand-in-2019/>
- Kementerian Kewangan Malaysia. (2017/2018). Laporan Ekonomi, ms 7. <https://www.parlimen.gov.my/ipms/eps/2017-10-27/CMD.26.2017%20-%20LAPORAN%20EKONOMI%202017%202018.pdf>
- Loke Ke Wei, K., & Mohd Thas Thaker, H. (2017). A qualitative inquiry into islamic home financing: Evidence from malaysia. *Qualitative Research in Financial Markets*, 9(2), 147-167.
- Meera, A.K.M & Larbani, M. (2009). Ownership effects of fractional reserve banking: an Islamic perspective. *Humanomics*, 25 (2), 101-116.
- Rosly, S.A. (2001). Iwad as a Requirement of Lawful Sale: A Critical Analysis. *IJUM Journal of Economics and Management*, Vol 9 (2), 187 – 201.
- Rosly, S.A. (2005). Critical Issues on Islamic Banking and Financial Markets. Author House.
- Shahwan, S., Mohammad, M. O. & Rahman, Z. A. (2013). Home Financing Pricing Issues in the Bay' Bithaman Ajil (BBA) and Musharakah Mutanaqisah (MMP). *Global Journal Al-Thaqafah*, Vol 3(2), 23-36
- Syed, S.A. (2012). Is Religiosity an Important Factor in Influencing the Intention to Undertake Islamic Home Financing in Klang Valley. <https://www.semanticscholar.org/paper/Is-Religiosity-an-Important-Factor-in-Influencing-Alam/b063f78852fb56cb7e2f4d3d3e427de2236fd18> DOI:10.5829/idosi.wasj.2012.19.07.292. Corpus ID: 14594465
- Subky, K. H. Liu, J. Y., Abdullah, M. Farhan Mokhtar, Z. and Faizrahman, A. (2017). The Implication of Musharakah Mutanaqisah in Malaysian Islamic Banking Arena: A Perspective on Legal Documentation. *International Journal of Management and Applied Research*, Vol. 4, No. 1, pp. 17-30. <https://doi.org/10.18646/2056.41.17-003>
- Zaharuddin, A. R. (2010). Contracts and The Products of Islamic Banking. CERT. Kuala Lumpur, Malaysia.

OPTIMIZATION OF MOSQUE FINANCIAL GOVERNANCE FOR THE PLANNING OF ACTIVITIES IN SUPPORTING THE ECONOMY OF MOSQUE IN INDONESIA

Annisa Fitri Anugrah Sari,

Indonesia

Abstract

Indonesia is one of the countries with the largest Muslim population in the world, reaching 209.1 million people (Databooks, 2019). Supporting these factors, mosques as places of worship for every Muslim are scattered in various regions in Indonesia. Among 264,591 mosques in Indonesia (SIMAS, 2020) it was found that the function of mosque financial management was still not optimal. The main problem is the lack of functioning of the mosque lies in the constraints of mosque financial governance. Currently, there are still many mosques that are managed traditionally using a manual system. The manual system is considered to be less professional because in fact using this system is able to make financial governance less structured. Reporting from *Republika* (2016) stated that there was a complaint from the Board of Mosque Prosperity in the West Sumatra Region which explained that the financial reports of mosques are sometimes lost or damaged and one of the causes is due to manual financial records and activities, even though all these financial reports must be accounted for properly. The Deputy Chairperson of Board of Mosque Prosperity in the same area also stated that the existence of digital financial bookkeeping can create flexibility and help mosque administrators to make transparent and increase accountability for all financial reports to stakeholders and other external parties. The research method used in this study is to use the Research and Development method which produces a product and tests the effectiveness of the product that has been produced, that the mosque financial management mobile application is expected to be able to provide convenience for mosque administrators in translating the finances of the mosque.

Keywords: Mosque financial governance, Economy of Indonesia, Board of mosque prosperity.

1.0 INTRODUCTION

Indonesia has the largest Muslim population in the world, reaching 209.1 million or equivalent to 87.2% (Databooks 2019). However, in reality, with such a large population, Indonesia is still unable to optimize the opportunity for this. Islam as a religion of *Rahmatan Lil Alamin* embraces and protects all creatures in all matters including in the economic field. Islamic economics does not position its main objective in the form of only material aspects, because Islam positions economic activity as a noble activity by presenting a just and welfare motive. Therefore, the form of achievement in Islam in the economic field is the achievement of *Falah* which means victory, success and prosperity as applied during the time of the Prophet. At the time of the Prophet, a mosque had one function, namely being able to prosper the economy by achieving social security and the operation of one of the Islamic economic instruments, namely *ZISWAF* (Alwi 2015).

Based on data recorded in the 2020 *Sistem Informasi Masjid* (SIMAS) held by Religion Ministry of Indonesia, there are 264.591 mosques with various topologies in Indonesia. The Indonesian Mosque Council states that the number of mosques in Indonesia is the largest in the world, especially in the Capital City, namely DKI Jakarta, there are 3,077 mosques for all types of mosque topologies. Board of mosque prosperity of the North Sumatra Indonesian Mosque, Ust. Irhamudin Siregar stated that the potential of mosques in Indonesia is fantastic. Not only as a place of worship but can be more productive if managed properly. Not only productive in managing places of worship, if mosque finances can be managed properly and correctly for the benefit of the people, it can be a solution in solving the problem of poverty.

Judging from the fantastic potential of mosques, mosques should be able to prosper the economy in Indonesia. In fact at this time, the mosque was not fully managed properly. The problem that arises from poor mosque management is due to manual financial management and has an impact on archiving management which should be transparent and accountable to related parties including stakeholders who are integrated with every board of mosque prosperity in Indonesia.

The main study in this study was reported by one of the republic reports, that the board of mosque prosperity in the West Sumatra region complained about the existence of mosque financial reports that were sometimes lost or damaged. The reason was due to financial records and activities that were still manual. In fact, all of these financial reports must be accounted for properly. The Deputy Chairperson of the board of mosque prosperity in the same area, also stated that the existence of digital financial bookkeeping can provide flexibility in accessing and can assist mosque administrators in translating all financial reports to stakeholders and other external parties. If this digital recording can be applied by all mosques, then the financial records of mosques throughout Indonesia will be in one standard and financial consolidation will be possible. Deputy Secretary General of the Indonesian Ulema Council, Amirsyah Tambunan, advised the Indonesian Mosque Council to strengthen mosque governance or management. And he also supports that it is time for mosques to be managed through transparent and accountable management so that their management can be accounted for.

In line with Randa's research (2011), accountability for every organization, both private and non-governmental organizations, including Church organizations, is very much needed because every organization has links with internal and external parties of the organization. Gray et al. (2006) in Randa (2011), states that accountability is the right of the community or groups in society that arise because of the relationship between the organization and society. On the other hand, accountability is the right and obligation of the organization (Lehman, 1999, 2005) in (Randa, 2011), but practice in Non Government Organizations (NGOs) is still very weak (Fries, 2003 and Brown & Moore, 2001) in (Randa, 2011).

So it is time for the Mosque Prosperity Council in Indonesia to start switching to a financial management system and planning activities in a digital system, which is strengthened by internet penetration data by the Ministry of Information and Communication in 2020, which reached 64.8% and good smartphone usage data by the public. Indonesia, attached data from Hootsuite in 2020 that there are around 59%.

In connection with the existing background, our literature review is the research of Munawaroh (2008), with the title of the thesis "Management of the Al-Aqsa Qudus Mosque (Management Review of Da'wah)" which is the discussion of this research is to examine how management or management is carried out by community managers. with the mobile application of management theories in every activity that is held in order to achieve da'wah goals. In line with the theory proposed by Dr. Ir. Hayu Prabowo as the Chairperson of the Institute for Environmental Breeding, stated that the role and function of a mosque is not only as a ritual place (mahdhah) but also a wider social worship (ghairu mahdhah) in the fields of economy, education, socio-culture and others. So that the mosque has a strategic role as a center for community development in an effort to protect, empower, and unite to create a quality, moderate and tolerant people.

Therefore, the purpose of this study is to determine the effect of optimizing mobile applications in financial governance for planning mosque activities that can support economic development in Indonesia.

Research Goals

This study aims to measure the optimization in mosque financial governance that affects the planning of mosque activities in Indonesia by using mosque function variables, mosque financial governance, and mobile applications.

2.0 THEORITICAL REVIEW

2.1 Mosque's Goals

In maximizing the function of the mosque as a whole, not only as a place of worship, it requires managers who are competent in terms of knowledge and skills. Not only in 'pious in terms of religious knowledge, but also proficient in management science. Therefore, there are several aspects that need to be considered in order to improve the function of the mosque, namely organizational aspects and also aspects of human resources (Hentika, N. P, Suryadi & Rozikin 2009).

2.2 Mosque Financial Governance

The mosque institution is a form of non-profit organization in the religious field, in accordance with the statement of Financial Accounting Standards no. 45 of 2011 concerning non-profit organizations, that non-profit organizations must and have the right to make financial reports and report to users of financial statements.

We often find that in many mosques financial reports are written on a bulletin board in a makeshift way, often not

even updated. If there is any, the financial reporting system is still in the usual format in accordance with the understanding of the managers, who in fact do not have financial management skills. Recording and reporting usually takes the form of recording incoming and outgoing money. The financial statements are prepared only as a form of accountability to the congregation. Maybe this is the form of transparency and accountability of the existing mosques (Andarsari 2016)

Do not let mosque finances become a source of conflict due to the lack of transparency and accountability in managing funds (Yusuf, T., & AbdurRaheem 2013). Therefore, as a symbol and representation of Muslims, mosque finances must be managed professionally in accordance with the financial management standards of non-profit organizations.

Judging from the purpose of the financial statements, transparent and relevant mosque financial reports are very important. Because mosque financial reports affect the trust of the surrounding community and encourage people to participate in prospering the mosque. In addition, the mosque's financial reports need changes, not just written on the announcement board briefly or even only announced during Friday prayers. The change that needs to be done is to take advantage of current technology, because in this era, people need information including mosque financial information, with easy and fast access.

2.3 Mobile Application

Mobile applications are software that run on mobile devices such as smartphones or tablet PCs. Mobile applications are also known as applications that can be downloaded and have certain functions, thereby adding to the functionality of the mobile device itself. To get the desired mobile application, users can download it through a specific site according to their operating system. Google Play and iTunes are some examples of sites that provide various applications for Android and iOS users to download the desired application (*Mobile Marketing Association*, 2015).

3.0 HYPOTHESIS

Based on the theoritis and the results of previous research, the following hypothesis is compiled: H1: mosque financial mobile applications have a positive and significant influence on mosque financial governance
H2: mosque financial mobile applications have a positive and significant effect on planning mosque activities.

4.0 RESEARCH METHODS

4.1 Population

The population in this study were mosques in Indonesia with the number recorded in the 2020 *Sistem Informasi Masjid* (SIMAS) held by Religion Ministry of Indonesia, there were 264.591 mosques with various topologies in Indonesia.

4.2 Sample

In this study, the authors took a sample of 540 mosques in Indonesia. This sampling technique uses probability sampling techniques by means of simple random sampling.

5.0 DISCUSSION

5.1 The Impact of Mosque Financial Mobile Applications on Mosque Financial Management

Table 1. T-test for Mosque Financial Mobile Application on Mosque Financial Governance

Coefficients ^a						
Model	Unstandardized Coefficients	Std. Error		Standardized Coefficients	t	Sig.
1	(Constant)	6.974	2.959		2.357	.027
	APK_Keuangan	4.416	.854	.733	5.169	.000

Hypothesis testing of mosque financial mobile applications on mosque financial governance is declared "accepted". This is because the significance value in the T-test on this variable is 0,000 and it fulfills the requirements for the acceptance of the hypothesis, namely the significant value must be less than 0.05.

Table 2. Coefficient of Determination for Mosque Financial Mobile Application on Mosque Financial Governance

Model Summary ^b				
Model	R	R Square	Adjusted R Square	Std. Error of the Estimate
1	.733 ^a	.537	.517	14.00269

The result of the calculation of the coefficient of determination shows that the value of R square (R^2) is 0.537. Thus, the effect of mosque financial mobile applications simultaneously on mosque financial governance is 53.7%, while the remaining 46.3% is influenced by other variables. This supports the t test, and illustrates that the influence of mosque financial mobile applications is quite large on mosque financial management, so that to make mosque financial governance good, it is necessary to use financial mobile applications at mosques.

5.2 The Impact of Mosque Financial Mobile Application on Mosque Activity Planning

Table 3. T-test for Mosque Financial Mobile Application on Mosque Activity Planning

Coefficients ^a						
Model		Unstandardized Coefficients		Standardized Coefficients		
		B	Std. Error	Beta	t	Sig.
1	(Constant)	6.614	2.955		2.239	.035
	APK_Keuangan	4.666	.853	.752	5.471	.000

Hypothesis testing of mosque financial mobile applications on the planning of mosque activities is declared "accepted". This is because the significance value in the t test on this variable is 0,000 and it fulfills the requirements for the acceptance of the hypothesis, namely the significant value must be less than 0.05.

Table 4. Coefficient of Determination for Mosque Financial Mobile Application on Mosque Activity Planning

Model Summary ^b				
Model	R	R Square	Adjusted R Square	Std. Error of the Estimate
1	.752 ^a	.565	.547	13.97917

The result of the calculation of the coefficient of determination shows that the value of R square (R^2) is 0.537. Thus, the effect of the mosque financial application simultaneously on the planning of mosque activities is 56.5% while the remaining 44.5% is influenced by other variables. This supports the t test, and illustrates that the influence of mosque financial applications is quite large on planning mosque activities, so that in order to plan mosque activities effectively and efficiently, it is necessary to use financial applications at mosques.

In today's modern era, it cannot be denied that the internet is something that must be owned and accessed by everyone. Viewed in 2018, internet users in Indonesia reached 95.2 million users. In the following year in 2019, based on data from the Indonesian Internet Service Providers Association in 2019, Henry Kaysfi as Secretary General of them stated that out of a total population of 264 million Indonesians, there were 171.17 million people or around 64.8% residents who are connected to the internet. It can be concluded that the internet is very much needed in this modern era, it can be seen from the potential of the internet which is finally able to provide optimization in a mosque's financial management. One that is frequently visited by internet users is an application. The application is able to be one of the strategies that can be done to optimize the management of mosque finances in order to make it easier for mosque administrators and congregations.

In addition, this application is able to make the financial reports of existing mosques transparent, so that everyone can see the income and expenses that occur in a mosque. With the activity planning application, a mosque's financial management will be more modern in this digitalization era. One of the obstacles in mosques today is manual bookkeeping and using paper media. This makes it difficult for the public to access and find out how the current condition of each mosque, especially in the financial sector, is an important thing to always be controlled and to influence public trust. If this obstacle can be faced, it will create transparency in financial statements and be able to optimize the function of the mosque by making the mosque prosperous.

A mosque can be said to be prosperous if the function of the mosque is carried out. In carrying out this function, financial reports are a determinable indicator of success. If a financial report is clear, then a mosque can be said to be prosperous.

6.0 CONCLUSION

This research was conducted with the aim of measuring the factors that can optimize mosque governance. The variables tested were mosque financial mobile applications (X), mosque financial governance (Y1), and mosque activity planning (Y2). From the hypothesis test conducted by the researcher, the results are as follows:

- i. Mosque financial mobile applications have a positive and significant influence on mosque financial governance. So, it can be concluded that the mosque financial application is one of the factors that can affect mosque governance in the financial department.
- ii. Mosque financial mobile applications have a positive and significant effect on planning mosque activities. So, it can be concluded that the mosque financial application is one of the factors that can affect the governance of the mosque in the activity planning section.

From these results, the authors conclude that mosque financial mobile applications are very necessary for mosque managers to optimize mosque governance, starting from financial management to managing activities that will be easily done by utilizing mosque financial mobile applications.

7.0 REFERENCES

- Alwi, Muhammad Muhib. 2015. "Optimalisasi Fungsi Masjid Dalam Pemberdayaan Ekonomi Masyarakat." *Al-Tatwir* 2(1): 133–52.
- Andarsari, P. R. 2016. "Laporan Keuangan Organisasi Nirlaba (Lembaga Masjid)." *Ekonika: Jurnal Ekonomi Universitas Kediri*: 143–52.
- Databooks. 2019a. "Penduduk Muslim Di Indonesia." <https://databoks.katadata.co.id/datapublish/2019/09/24/berapa-jumlah-penduduk-muslim-indonesia> (February 29, 2020).
- Databooks. 2019b. "Pengguna Internet di Indonesia." <https://databoks.katadata.co.id/datapublish/2019/09/09/berapa-pengguna-internet-di-indonesia> (Maret 02, 2020).
- Hentika, N. P., Suryadi & Rozikin, M. 2009. "Meningkatkan Fungsi Masjid Melalui Reformasi Administrasi: Studi Pada Masjid Al Falah Surabaya." *Jurnal Administrasi Publik (JAP)*: 305– 11.
- Prashadana, Y, & Nugroho, E. 2016. "Aplikasi Keuangan Rumah Tangga Berbasis Android." *Jurnal Ilmiah Go Infotech* 22.
- Yusuf, T., & AbdurRaheem, L. 2013. District Global Concept. *The Masjid: Basics & Management*. Kompas.com. (2019, May 16). Dipetik 2020, dari APJII: Jumlah Pengguna Internet di Indonesia Tembus 171 Juta Jiwa
- Hafidz Muhammad. 2018. "Jurnal Review Riset Pengelolaan Keuangan Masjid". diambil dari https://www.academia.edu/39726928/JURNAL_REVIEW_RISET_PENGELOLAAN_KEUANGAN_MESJID. Di akses pada 21 Maret 2020
- Latif Abdul. 2014. "Akuntabilitas dan Pengelolaan Keuangan di Masjid". diambil dari <http://eprints.ums.ac.id/32016/9/02.%20Naskah%20Publikasi.pdf>. Di akses pada 21 Maret 2020

ISU DAN CABARAN PELAKSANAAN WAKAF DALAM MEMBANGUNKAN EKONOMI UMMAH : ANALISIS TERHADAP SOROTAN KARYA

Nurul Akma Mohamed^a, Mujiburrahman Muhammad Saleh^b, Hamidi Abdul Ghani^c & Suraini Sauff^d

^{ac}Jabatan al-Syariah, Kolej Islam Antarabangsa Sultan Ismail Petra

^{bd}Jabatan Muamalat, Kolej Islam Antarabangsa Sultan Ismail Petra

Abstrak

Majoriti masyarakat Islam pada hari ini masih melihat dimensi wakaf dari sudut kefahaman tradisional yang terhad kepada pembinaan aset kekal; sebagai contoh, wakaf untuk membina masjid, pondok, pusat tahfiz dan tanah kubur. Di Malaysia, institusi wakaf masih tidak berfungsi sebaik mungkin dalam membangunkan ekonomi ummah. Berdasarkan laporan yang dikeluarkan oleh Jabatan Kemajuan Islam Malaysia (JAKIM) pada tahun 2002, negara ini mempunyai tanah wakaf seluas 20,735.61 ekar di seluruh negara. Permasalahan yang dibincangkan dalam artikel ini adalah berkenaan isu dan cabaran yang terpaksa dihadapi dan diharungi oleh institusi-institusi wakaf dalam memastikan kelancaran aktiviti wakaf dan kemampuannya untuk memberi sumbangan terhadap pembangunan ummah di Malaysia. Kajian ini digarap berasaskan kajian dokumentasi yang melibatkan analisis kandungan yang dijalankan bagi melihat kajian-kajian terdahulu. Hasil daripada kajian ini menunjukkan bahawa terdapat pelbagai isu dan cabaran yang masih dihadapi oleh institusi-institusi yang dipertanggungjawabkan untuk membangunkan harta wakaf di Malaysia. Kesimpulannya, isu dan cabaran yang dihadapi oleh institusi-institusi wakaf perlu diatasi dengan sebaik mungkin bagi memastikan harta wakaf dapat berperanan secara maksima dalam membangunkan ekonomi ummah, khususnya di Malaysia.

Kata kunci : *Isu dan Cabaran, Wakaf, Pembangunan Ekonomi Ummah*

1.0 PENDAHULUAN

Waqaf, secara ringkas, boleh didefinisikan sebagai harta yang disumbangkan di jalan Allah untuk dimanfaatkan oleh orang ramai. Ia adalah suatu sistem muamalat Islam yang wajar dikaji dan dibangunkan sebagai sebuah institusi kewangan Islam yang mampu menaiktaraf ekonomi negara, negeri, dan masyarakat. Wakaf juga merupakan salah satu daripada instrumen kewangan dalam *Siyasah Maliyyah* iaitu polisi fiskal negara dalam Islam. Menurut catatan sejarah, waqaf yang pertama di dalam Islam telah dilaksanakan sendiri oleh Nabi Muhammad ﷺ melalui pembinaan Masjid Quba' dan kemudian diikuti pula oleh pembinaan Masjid Nabawi di Madinah. Pembinaan dua masjid terawal di dalam sejarah Islam melalui kaedah waqaf ini adalah sangat penting di dalam pembangunan masyarakat kerana masjid-masjid tersebut telah terbukti keberkesannya sebagai pusat pentadbiran masyarakat. Dari sudut ibadah pula, para Fuqaha' berpandangan bahawa amalan waqaf mempunyai dua matlamat asas iaitu: pertama, untuk menyumbang kepada kebajikan masyarakat yang tertentu, dan kedua adalah sumber bekalan pahala secara berterusan untuk dibawa menghadap Allah kelak.

Meskipun sumbangan waqaf tidaklah diwajibkan terhadap umat Islam, namun ia merupakan satu bentuk pengabdian kepada Allah yang telah diberi jaminan bahawa penyumbangannya akan mendapat pahala yang berterusan walaupun sesudah meninggal dunia. Dari sudut yang berbeza, waqaf adalah suatu sistem kewangan yang menggalakkan umat Islam supaya menyumbang sebahagian daripada harta mereka untuk tujuan pembangunan masyarakat seperti pembinaan masjid, hospital dan klinik kesihatan, penginapan sementara, koperasi, perpustakaan dan sebagainya. Selain itu, waqaf juga berperanan sebagai penggerak ekonomi ummah melalui pembinaan sekolah, universiti, pusat latihan, dan sebagainya yang boleh dimanfaatkan oleh umat Islam untuk menguasai ilmu fardu ain dan fardu kifayah. Salah satu contoh kejayaan sistem waqaf yang masyhurlah pembinaan dan operasi Universiti Al-Azhar yang hampir keseluruhannya ditaja oleh dana wakaf yang diuruskan oleh *Wizaratul Awqaf Bi Misr* (Kementerian Waqaf Mesir). (SAAD, 2014)

Di Indonesia, Pesantren Modern Darussalam Gontor awal muncul dari dana wakaf kini pendiriannya dan pengaruh tersebar ke seluruh negeri di Indonesia dan mampu melahirkan para tokoh nasional dan internasional. Wakaf Gontor

berawal dari wakaf para pendiri pondok (Trimurti) yang mewakafkan harta milik mereka untuk kepentingan pendidikan dan dakwah Islamiyah. Tadbir urus diserahkan kepada sebuah lembaga yang dibentuk khusus untuk itu yang dinamakan “Badan Wakaf Pondok Modern Darussalam Gontor”. Badan wakaf ditugaskan untuk mengembangkan aset wakaf dengan membuka unit-unit usaha dan pusat-pusat perbelanjaan yang dikendalikan dengan sistem pengurusan modern. Pondok Modern Darussalam Gontor sekarang telah memiliki modal usaha yang besar mencapai ratusan miliar rupiah dan memiliki unit-unit usaha yang banyak. Menurut laporan Abdullah Syukri Zarkasyi, unit-unit usaha milik pondok di bawah koordinasi Kopontren berjumlah 25 buah, bahkan mencapai 50 buah apabila menghitung sub-sub unit yang tersebar di pondok-pondok cabang. Di antaranya berupa kilang pemprosesan padi, kilang air batu, kilang air minum, percetakan, kedai buku, kedai bahan bangunan, farmasi, perkhidmatan kereta sewa, penginapan, klinik kesehatan dan beberapa kantin. Penghasilan dari unit-unit usaha ini, Pondok Modern Darussalam Gontor setiap tahun memperoleh keuntungan bersih lebih dari 6 milyar rupiah, dan pada tahun 2009 naik mencapai 15 milyar rupiah yang digunakan untuk memfasilitasi pengembangan pondok, menggaji guru (ustadz), pensyarah, staf, biasiswa dan kegiatan-kegiatan akademik lainnya.

Majoriti masyarakat Islam pada hari ini melihat dimensi wakaf dalamsudut yang sangat terhad kepada amalan ritual semata-mata sebagai contoh wakaf untuk bina masjid, pondok, pusat tahfiz dan tanah kubur. Tidak dinafikan bahawa kesanggupan pewakaf untuk berwakaf bagi tujuan tersebut di atas mempunyai signifikan yang tersendiri, namun ianya tidak dapat membina kekuatan untuk terus berdaya saing dan memberi impak yang lebih holistik kepada masyarakat Islam. Ini adalah kerana, bagi menguruskan institusi masjid, pondok, pusat tahfiz dan tanah kubur memerlukan dana yang berterusan untuk memastikan institusi tersebut terus memainkan peranannya dalam masyarakat. Tanpa pembiayaan atau dana yang mencukupi maka institusi-institusi tersebut tidak dapat berfungsi dengan baik dan lebih malang lagi ianya akan membazirkan aset wakaf yang ada.

Di Malaysia, institusi wakaf masih tidak berfungsi sebaik mungkin dalam membangunkan ekonomi ummah. Menurut Jabatan Kemajuan Islam Malaysia (JAKIM),¹ negara ini mempunyai seluas 20,735.61 ekar tanah wakaf di seluruh negara. Amat rugi jika keluasan tanah wakaf ini diabaikan kerana ia berpotensi besar untuk meningkatkan taraf sosial dan ekonomi masyarakat, khususnya umat Islam di negara ini, di samping kaum-kaum lain. Walaupun tanah wakaf ini bertaburan dan tidak begitu ekonomik untuk dibangunkan, namun perancangan pembangunan tanah wakaf wajar diteruskan supaya memberi manfaat kepada masyarakat Islam.² Ada beberapa cabaran dan isu yang dihadapi oleh institusi wakaf dalam mengurus dan mengembangkan aset-aset wakaf. Kajian ini akan menyorot beberapa karya penulisan yang menyentuh tentang isu dan cabaran ini sebagai referensi ilmiah untuk memberikan solusi semasa kepada permasalahan yang dihadapi oleh Institusi wakaf di Malaysia.

2.0 METODOLOGI KAJIAN

Kajian ini secara teorinya merupakan kajian yang bersifat kualitatif, iaitu kajian yang mengadaptasi metode pengumpulan data melalui penganalisisan kandungan dokumen. Pengumpulan data kajian melalui kajian kepustakaan yang mana rujukan dibuat kepada sumber primer dan sekunder melibatkan kitab-kitab turath sebagai rujukan utama berkaitan wakaf, dan juga sumber lain seperti buku, jurnal, artikel, kertas persidangan, seminar, kertas penyelidikan, tesis, keratan akhbar, carian di internet dan seumpamanya sama ada dalam Bahasa Melayu, Bahasa Arab dan Bahasa Inggeris.

3.0 DEFINISI PEMBANGUNAN

Dalam bahasa melayu, istilah “pembangunan” didefinisikan dengan maksud perihal membangun, proses membangun (mencapai kemajuan dan perkembangan). Pembangunan juga membawa maksud usaha atau kegiatan membangunkan (memajukan dan mengembangkan).³

¹ Laporan daripada Bahagian Penyelidikan JAKIM pada 2002.

² Mohd Saharudin bin Shakrani (2003), Tinjauan Isu-isu yang membataskan Penggunaan Wakaf Dalam Pembangunan Ekonomi Ummah di Malaysia, Jurnal Syariah, m.s 75.

³ Kamus Dewan Bahasa dan Pustaka, Edisi Keempat.

⁴ *Mu'jam al-Lughah al-'Arabiyah al-Mu'asir*, m.s 123.

Manakala pembangunan dalam bahasa Arab pula disebut dengan kalimat *at-tanmiyah* yang membawa erti bertambah dan banyak.⁴ Terdapat pelbagai pendapat dalam mendefinisikan kalimat pembangunan ini, perbezaan ini berlaku kerana bidang dan kesempurnaan maksud pembangunan itu sendiri. Sebahagiannya pembangunan didefinisikan hanya terhadap kepada bidang ekonomi sahaja, manakala yang lain mendefinisikan pembangunan pada semua bidang kehidupan manusia samada yang berbentuk ekonomi, pendidikan, sosial dan sebagainya.⁵

4.0 DEFINISI EKONOMI

Istilah ekonomi berasal daripada perkataan Yunani, iaitu *oicos* dan *namos* yang membentuk istilah *oiconoms* ataupun *oiconomicus* dan kemudiannya dipindahkan ke bahasa lain dengan sebutan *economie* yang membawa maksud urusan yang berkaitan dengan pentadbiran rumah tangga.⁶

Jika ditinjau dari segi bahasa Arab ia berasal daripada istilah *Qasada* seterusnya menerbitkan perkataan *al-Iqtisad* yang membawa maksud jalan yang lurus, adil dan pertengahan antara dua keadaan iaitu antara *al-ifrat* dan *al-tafrit*.⁷ Manakala dari segi istilah *fuqaha* pula, *al-Iqtisad* didefinisikan dengan maksud “*al-tawassut*” iaitu pertengahan antara *al-ifrat* (mengurangi) dan *al-tafrit* (berlebihan) di mana kedua-dua memiliki maksud yang saling bertentangan antara satu sama lain.⁸

5.0 DEFINISI UMMAH

Istilah *ummah* biasanya dimaksudkan adalah umat Islam.⁹ Kalimat *ummah* ini dideskripsikan oleh Allah SWT dalam *al-Quran* dalam bentuk *mufrad* sebanyak 50 kali. Berikut adalah beberapa maksud *ummah* yang terkandung dalam ayat-ayat *al-Quran*, antaranya

Pertama : waktu dan tempoh, seperti yang dinyatakan dalam surah *Hud* : 8.

Kedua : pemimpin yang mengetahui serta mengajak kepada kebaikan, seperti yang dinyatakan dalam surah *al-Nahlu* : 120.

Ketiga : jalan yang diikuti, seperti dalam surah *al-Zuhruf* : 22.

Keempat : sekumpulan manusia secara umum, seperti firman Allah SWT dalam surah *al-Qasas* : 23.

Kelima : sekumpulan manusia yang menganut satu agama tertentu, seperti dalam surah *al-Nahlu* : 93.

Keenam : sebahagian orang dari penganut agama tertentu, seperti yang dinyatakan dalam surah *Ali Imran* : 104.

6.0 DEFINISI WAKAF

Wakaf dari segi bahasa bermaksud menegah.¹⁰ Jumhur *fuqaha* di antaranya pendapat Abu Yusuf dan Muhammad bin Hasan dari mazhab Hanafi, mazhab Syafie dan mazhab Hanbali mendefinisikan wakaf adalah menegah harta beserta manfaatnya dengan mengekalkan asal aset, menyekat hak mengurus dari si pewakaf menjadi hak pengurus baharu untuk tujuan kebajikan dan kebaikan semata-mata untuk mendekatkan diri kepada Allah SWT.¹¹

Mujiburrahman MS (2016), *Al-Waqf: Dirasah Tatbiqiyah fi Indonesia*, Jurnal KIAS Bil.XI/ Vol.11, m.s. 188.

⁶ Sarimah Hanim Aman Shah (2005), *Ekonomi dari Perspektif Islam*, Fajar Bakti Sdn. Bhd, m.s. 14.

⁷ *Lisanul 'Arab, Bab "al-Qasd" Juzuk 3, m.s. 353.*

⁸ Dr. Nuriyah Hamad, *Mu'jamal-Mustalahat al-Maliyah wal Iqtisadiyah fi Lughatil Fuqaha*, m.s. 72.

⁹ Kamus Dewan Bahasa dan Pustaka, Edisi Keempat.

7.0 SEJARAH PERKEMBANGAN WAKAF DALAM SEJARAH ISLAM

Wakaf merupakan institusi yang terletak di bawah sistem perundangan Islam berteraskan al-Qur'an dan hadith. Dalam sejarah Islam, institusi wakaf ini muncul hasil inspirasi dari al-Quran dan hadith yang kemudian diperkukuhkan oleh ijma ulama.¹²

Menurut perspektif sejarah, beberapa sektor dalam masyarakat Islam seperti pelajaran dan pendidikan, kesihatan, kebajikan masyarakat, penjagaan alam sekitar, kajian sains dan perubatan, ketenteraan dan pertahanan dan lain-lain sektor adalah dibiayai oleh hasil pendapatan daripada aset wakaf yang dilaburkan. Umpamanya, dilaporkan bahawa kepulauan Sicily, semasa berada di bawah pemerintahan Islam, telah mempunyai 300 sekolah rendah yang dibina dengan hasil pendapatan wakaf dan ini mencakupi perbelanjaan menguruskan sekolah seperti gaji tenaga pengajar dan peralatan sekolah. Hasil pendapatan wakaf juga digunakan untuk membiayai perbelanjaan pembinaan dan pengurusan sekolah-sekolah tinggi dan universiti-universiti di bandar-bandar besar seperti al-Aqsa, Damsyik, Baghdad, Kaherah, Nisapur dan lain-lain lagi. Di antara universiti-universiti yang besar yang pernah dibiayai oleh hasil pendapatan wakaf ialah Universiti al-Azhar di Kaherah, Universiti al-Qurawiyin di Kota Fez dan Universiti al-Nizamiyyah di Baghdad. Ini mencakupi segala perbelanjaan pengurusan seperti alat mengajar, buku-buku sains, gaji untuk pengajar, biasiswa untuk pelajar dan asrama untuk pelajar sama ada bujang atau berkahwin. Dalam aspek sosial, hasil pendapatan wakaf digunakan untuk membantu golongan miskin dan mereka yang mengembara. Kes wakaf tanah Saidina 'Umar di Khaibar adalah bertujuan memberikan kebajikan kepada mereka yang memerlukan bantuan. Begitu juga dalam kes telaga rumah yang diwakafkan untuk faedah semua orang yang memerlukan air di Madinah. Hasil pendapatan wakaf juga digunakan untuk membebaskan hamba abdi, membesarkan anak-anak yatim dan menyediakan air untuk kampung-kampung. Ia juga digunakan untuk penjagaan binatang dan burung, membaik pulih tebing sungai dan menyediakan kubu pertahanan.¹³

8.0 SEJARAH PERKEMBANGAN WAKAF DI MALAYSIA

Pengurusan dan pentadbiran wakaf diletakkan di bawah Majlis Agama Islam setiap negeri dan Majlis Agama Islam negeri merupakan pemegang tunggal kepada semua harta wakaf di Malaysia. Perkara ini ditetapkan melalui perundangan bagi setiap negeri. Contohnya di Selangor, Seksyen 89, Enakmen Pentadbiran Agama Islam (Negeri Selangor) 2003 menyatakan 'Majlis menjadi pemegang amanah tunggal wakaf, nazar dan amanah.'¹⁴

Untuk membantu urusan pentadbiran dan pengurusan wakaf, Kerajaan Malaysia telah mengisytiharkan penubuhan Jabatan Wakaf, Zakat dan Haji (JAWHAR) pada 27 Mac 2004 bersamaan Safar 1425H oleh YAB Dato' Seri Abdullah bin Ahmad Badawi. Manakala, pelancaran rasmi JAWHAR pula telah disempurnakan pada 8 Oktober 2004 bersamaan 23 Syaaban 1425H oleh YB Dato' Dr. Abdullah bin Md Zin, Menteri di Jabatan Perdana Menteri. Penubuhan JAWHAR ini adalah bertujuan untuk memastikan bahawa pentadbiran harta wakaf, zakat, mal dan haji di seluruh negara lebih sistematik, tersusun dan berkesan.¹⁵

¹⁰ *Lisanul 'Arab, Bab "al-Qasd" Juzuk 9, m.s. 359, Kamus al-Muhit, Bab Huruf Wau, Juzuk 1, m.s 1112, Mukhtar al-Sihah, Juzuk 1, m.s. 347.*

¹¹ *Fathul Qadir 5/37-40, al-Lubab 2/180, al-Dar al-Mukhtar 3/391, Mujiburrahman MS (2016), Al-Waqf: Dirasah Tatbiqiyah fi Indonesia, Jurnal KIAS Bil.XI/ Vol.11, m.s. 188.*

¹² Razali Othman (2015), *Institusi Wakaf Sejarah dan Amalan Masa Kini*, Dewan Bahasa dan Pustaka, m.s. 36.

¹³ Hamidi Abdul Ghani (2013), *Saham Wakaf Menurut Perspektif Islam : ke Arah Pelaksanaannya di Negeri Kelantan*, Jurnal KIAS Bil. VIII, m.s.182.

9.0 ISU DAN CABARAN PERKEMBANGAN WAKAF DI MALAYSIA

Terdapat pelbagai penulisan dan kajian yang dilakukan berkaitan dengan topik isu dan cabaran pelaksanaan wakaf dalam membangunkan ekonomi ummah. Secara umumnya, hasil sorotan karya-karya dari penulisan dan kajian lepas, kami mendapati beberapa isu dan cabaran pelaksanaan wakaf dalam membangunkan ekonomi ummah di antaranya dana kerajaan yang terbatas, pendaftaran tanah wakaf, pangkalan data tanah wakaf, lokasi dan saiz tanah wakaf, pencorobohan tanah wakaf, tiada piawaian perakaunan wakaf, tenaga profesional dalam aspek perancangan dan pembangunan tanah wakaf, dan tahap kesedaran masyarakat.

Antara penulisan yang berkaitan adalah sepertimana yang ditulis oleh Ahmad Ibrahim dalam artikelnya bertajuk Wakaf dari Perspektif Undang-undang Islam, Amalan dan Permasalahannya di Malaysia.¹⁶ Di antara masalah pengurusan wakaf yang dikemukakan oleh beliau adalah tidak ada peruntukan undang-undang mengenai bidang kuasa yang diberikan kepada pihak yang dipertanggungjawabkan, tindakan undang-undang terhadap penceroboh harta wakaf, tuntutan-tuntutan pewaris wakaf yang tidak dipindah hak milik, kekurangan kakitangan, masyarakat belum cukup faham amalan wakaf yang sebenarnya, rekod-rekod harta wakaf tidak lengkap, dan tindakan mengenai sewa yang tidak munasabah. Beliau juga menyampaikan beberapa saranan bagi mengatasi masalah-masalah tersebut, di antaranya:

- i. Hendaklah ditubuhkan satu jabatan khas Pentadbiran Wakaf, Zakat dan Baitulmal dengan kuasa autonomi yang tersendiri sama ada dalam bentuk kementerian atau yayasan.
- ii. Satu lagi undang-undang yang juga menghalang 'pembangunan' tanah-tanah wakaf ialah Akta Kawalan Sewa 1966 (*Rent Control Act 1966*). Akta ini tidak membenarkan perubahan atau kenaikan sewaan kepada rumah kepada bangunan-bangunan yang dibina sebelum 31 Januari 1948. Akibatnya banyak rumah kedai dan rumah kediaman milik Majlis Hal Ehwal Agama Islam yang dibina sebelum tahun 1948 tidak dapat dinaikkan sewa walaupun rumah kedai atau rumah kediaman di kawasan berkenaan pada hakikatnya kadar sewaan mengikut pasaran adalah lebih tinggi daripada apa yang dikenakan oleh Akta berkenaan seperti di Pulau Pinang, Wilayah Persekutuan dan lain-lain negeri. Sepatutnya Akta ini hendaklah mengecualikan peruntukkan khususnya yang melibatkan tanah-tanah wakaf.¹⁷
- iii. Seksyen 2 Akta Pemegang Amanah 1969 (*The Trustee Act 1969*) hendaklah dipinda kepada:
 - iv. "Mahkamah" bermakna Mahkamah Tinggi di Malaya atau Mahkamah Tinggi di Borneo yang mana berkenaan dan masuk dalam kes Pegangan Amanah, dan Pusaka Orang-orang Islam, Mahkamah Tinggi Syari'ah. Begitu juga tambahan kepada Seksyen 2 (4) Akta yang sama perlu dipinda seperti berikut:
 - v. Dalam Akta ini, "TRUST (Pegangan Amanah) tidak termasuk wakaf yang diwujudkan mengikut prinsip-prinsip undang-undang Islam."¹⁸
- vi. Akta Pengambilan Tanah 1960 juga perlu dipinda supaya tidak membenarkan tanah-tanah wakaf terutamanya wakaf untuk masjid dan surau diambil balik oleh kerajaan untuk apa-apa tujuan sekalipun.¹⁹
- vii. Takrif 'wakaf' dalam Kanun Tanah Negara juga perlu dikaji semula dan diberi takrif yang lebih sesuai dari sudut memberi pemahaman yang jelas dan seragam di peringkat pelaksanaan.
- viii. Bab khas mengenai wakaf perlu diwujudkan untuk membuat peraturan mengenai cara pendaftaran harta wakaf di bawah Kanun Tanah Negara dengan lebih mudah.
- ix. Satu Akta khas mengenai Pentadbiran Wakaf dan Baitulmal perlu diwujudkan.
- x. Jawatankuasa Pembangunan Ekonomi yang terdiri daripada ahli-ahli ekonomi dan perundangan Islam perlu diwujudkan.

¹⁴ Asmak Ab Rahman (2009), Peranan Wakaf Dalam Pembangunan Ekonomi Umat Islam Dan Aplikasinya Di Malaysia, Jurnal Syariah, Jilid 17, Bil.1, m.s. 121.

¹⁵ Jabatan Wakaf, Zakat dan Haji (2008), *Laporan Tahunan JAWHAR 2007*. Malaysia : JAWHAR, m.s. 6.

¹⁶ Othman, M. Z. (1998). Wakaf Dari Perspektif Undang-undang Islam, Amalan dan Permasalahannya di Malaysia. *Dlm. Ahmad Ibrahim (1998). (Eds.) et. al, Al-Ahkam, Jilid, 6, m.s. 15.*

Di samping itu, terdapat penulisan yang berkaitan isu dan cabaran pengurusan di Malaysia yang ditulis oleh Asmak Ab Rahman dalam artikelnya yang bertajuk Peranan Wakaf dalam Pembangunan Ekonomi Umat Islam dan Aplikasinya Di Malaysia.²⁰ Artikel ini membincangkan tentang konsep berkaitan wakaf, kepentingan aghhan semula kekayaan untuk pembangunan ekonomi dan bagaimana wakaf berperanan dalam pembangunan ekonomi negara. Wakaf memainkan peranan dalam mengurangkan kadar kemiskinan, perkhidmatan kesihatan, pendidikan, pusat penjagaan anak yatim, masjid dan tempat tinggal yang diperlukan oleh masyarakat awam.

Isu dan cabaran pelaksanaan wakaf di Malaysia turut diulas dalam penulisan Datuk Haji Anan bin C. Mohd dengan tajuk artikel Pembangunan Wakaf Menerusi Pendanaan Kerajaan Dan Kerjasama Institusi Kewangan Dan Korporat : Hala Tuju, Cabaran Dan Harapan.²¹ Objektif dari artikel ini adalah bagi menyentuh hala tuju, cabaran dan harapan JAWHAR untuk memastikan pembangunan hartanah wakaf di Malaysia dapat dilaksanakan dengan lancar dan berkesan. Antara Isu-isu pembangunan wakaf dan cadangan penambahbaikan yang dilontarkan dalam penulisan ini adalah sebagaimana berikut :

¹⁷ Akta Kawalan Sewa 1966.

¹⁸ Kanun Tanah Negara 1966 (Akta no. 50 Tahun 1966).

¹⁹ Akta Pengambilan Tanah 1960 (Akta No, 34 Tahun 1960).

²⁰ Asmak Ab Rahman (2009), Peranan Wakaf Dalam Pembangunan Ekonomi Umat Islam Dan Aplikasinya Di Malaysia, Jurnal Syariah, Jilid 17, Bil.1

²¹ Datuk Haji Anan bin C. Mohd (2015), Pembangunan Wakaf Menerusi Pendanaan Kerajaan Dan Kerjasama Institusi Kewangan Dan Korporat : Hala Tuju, Cabaran Dan Harapan.

NO	ISU	CADANGAN PENAMBAHBAIKAN
1	Dana kerajaan yang terbatas	Peruntukan yang disediakan oleh kerajaan di bawah RMKe-9 dan RMK-10 masih tidak mencukupi untuk membiayai projek-30 projek pembangunan hartanah wakaf. Justeru itu, di samping pendanaan kerajaan, usaha-usaha lain perlu dilakukan segera bagi mencari dana alternatif untuk membiayai projek pembangunan hartanah wakaf antaranya mengadakan kerjasama lautan biru (NBOS) dengan GLC/Korporat dan Syarikat Swasta dan Institusi Kewangan. Usaha in sedang dilakukan oleh JAWHAR dan dipergiatkan lagi dengan melibatkan lebih banyak pihak lain seperti PRIMA, PPA1M, Jabatan Perumahan Negara, TERAJU, Syarikat-Syarikat Korporat dan Institusi Kewangan.
2	Pendaftaran tanah wakaf	Bagi membolehkan tanah wakaf lama didaftarkan JAWHAR telah menerbitkan Manual Pengurusan Peletakhakan Tanah Wakaf bagi membantu MAIN mendaftarkan tanah wakaf di Pejabat Tanah Daerah dan Galian secara teratur. Dalam masa yang sama Sistem Pendaftaran Tanah Berkomputer (SPTB) di Pejabat Tanah dan Galian negeri – negeri telah dikemaskini dengan menyediakan coding pendaftaran wakaf. Menerusi penambahbaikan ini perkataan ‘wakaf’ dicatatkan dalam geran hakmilik tanah sebagai mengesahkan bahawa tanah itu adalah tanah wakaf.
3	Pangkalan data tanah wakaf	JAWHAR telah mewujudkan data bank tanah wakaf e-Wakaf dan e-Bayanat. Setiap MAIN telah mewujudkan bank tanah wakaf di negeri masing- masing. Maklumat data tanah wakaf di <i>upload</i> ke sistem e-wakaf JAWHAR dan boleh dikemaskini secara <i>on-line</i> oleh MAIN. Ketika ini sistem e-wakaf dalam pengemaskinian dan akan diganti dengan sistem lain yang lebih terkini menggunakan Sistem Geospacial Maklumat(GIS).
4	Lokasi dan saiz tanah wakaf	Kaedah istibdal adalah satu kaedah yang dibenarkan untuk memajukan tanah wakaf. Walaubagaimana pun proses pelaksanaannya perlulah melalui proses yang ketat dengan mematuhi syarat dan keperluan yang telah ditetapkan oleh syarak antaranya tanah wakaf asal tidak ada lagi manfaatnya dan harta itu tidak lagi menepati matlamat dan tujuan sesuatu wakaf itu dibuat. Tanah yang <i>diistibdal</i> perlulah diganti dengan harta yang lain yang sama atau lebih tinggi nilainya. Manual Pengurusan Istibdal Wakaf pada 2010 telah diterbitkan oleh JAWHAR sebagai panduan kepada MAIN dan bagi tujuan pelaksanaan istibdal wakaf. Manual ini juga telah menjadi panduan dan rujukan universiti tempatan.
5	Pencorobohan tanah wakaf	Tiada sebarang cadangan penambahbaikan.
6	Tiada piawaian perakaunan wakaf	Pelaksanaan Piawaian Perakaunan Islam termasuk Waqaf, Zakat dan Mal dalam peringkat kajian. Tindakan ini dilakukan dengan kerjasama JAWHAR dengan Jabatan Akauntan Negara, Jabatan Audit Negara, MAIN, Universiti Awam.
7	Tenaga professional dalam aspek perancangan dan pembangunan tanah wakaf	Penubuhan Perbadanan Wakaf di setiap negeri berupaya meningkatkan kecekapan pengurusan wakaf di setiap negeri. Di bawah pelaksanaan Fasa I (2014-2015) JAWHAR, seramai 3 Negeri telah menubuhkan Perbadanan Wakaf iaitu di Selangor, Negeri Sembilan, Wilayah Persekutuan untuk menguruskan hartanah wakaf secara professional agar potensi dan manfaat wakaf dapat dioptimumkan untuk masalah ummah.
8	Tahap kesedaran masyarakat	Bagi meningkatkan tahap kesedaran dan kefahaman masyarakat, JAWHAR melaksanakan beberapa aktiviti penerangan dan hebahan dilaksanakan menerusi program/aktiviti berikut: 1.Seminar Wakaf, Seminar Wakaf Serantau dan Seminar Wakaf Antarabangsa 2.JAWHAR Intelektual Discourse (JID)/Majlis Ilmu Bengkel Pemerksaan Tanah Wakaf di Johor 3.Bengkel Pembangunan Tanah Wakaf di Terengganu dan lain-lain.

		<p>4. Hebahan menerusi media elektronik seperti TV & Radio menerusi program Infaq dan akhbar menerusi rencana wakaf</p> <p>5. Kaji selidik dan Kajian Wakaf</p> <p>6. Kerjasama Strategik dengan pihak GLC, Syarikat Korporat/Swasta/Institusi Kewangan</p> <p>7. Mengadakan MoU dengan Institusi Pengajian Tinggi Spt USM, UPM, USIM, UKM</p> <p>8. Kursus Profesional Wakaf UIM, Cyberjaya dan Kursus Diploma wakaf dengan kerjasama Institut Baitulmal MAIWP, Kuala Lumpur</p> <p>9. Menerbit Buku-buku Manual Pengurusan Wakaf, Jurnal Wakaf JAWHAR, Taqvim/Cenderamata</p> <p>10. Taklimat kunjungan hormat dalam dan luar negara,</p> <p>11. Info wakaf menerusi Website/Face Book.</p> <p>12. Lawatan dan jemputan ceramah di Seminar/persidangan wakaf dalam dan luar negara.</p>
--	--	---

Artikel ini juga turut menerangkan tentang hala tuju pembangunan hartanah wakaf 10 tahun akan datang. Di antaranya 11 program yang dirangka khas bagi tempoh 10 tahun akan datang (2016-2025), antaranya program Program Smart Partnership Menerusi Strategi Lautan Biru (NBOS), Program Penubuhan Bank Wakaf, Program Pemerksaan Enakmen/Akta Wakaf, Program Penubuhan Perbadanan Wakaf di setiap Negeri, Program Pendanaan menerusi Penerbitan Sukuk/Pembiayaan Institusi Kewangan, Program Pemerksaan Data Tanah Wakaf, Program Wakaf Air/Wakaf Elektrik, Program Pemerksaan Tanah Rezab Melayu dan Tanah Milik Pesuruhjaya Tanah Persekutuan (PTP), Program Pendanaan Wakaf Pejawat Awam 1 Malaysia (PWPA 1M), Program Kumpulan Wang Amanah Wakaf Malaysia, dan JAWHAR : Satu penilaian dan penarafan semula.²²

Isu dan cabaran pengurusan wakaf di Malaysia juga dibincangkan oleh Rabiatul Hasanah Mahmood, Nazifah Mustaffha, Latifa Bibi Musafar Hameed, dan Norhanizah Johari dalam kajiannya bertajuk Pengurusan Wakaf di Malaysia: Isu dan Cabaran²³. Tujuan kajian ini dilakukan adalah untuk mengenal pasti isu dan cabaran institusi wakaf dalam melestarikan peranan sebagai instrumen kewangan Islam. Kajian ini mendapati wujud pelbagai cabaran yang terpaksa dihadapi dan diharungi oleh pusat wakaf dalam memastikan kelancaran aktiviti wakaf di Malaysia. Di antara cabaran tersebut adalah kekurangan dana, kawalan dalaman, kepincangan pangkalan data, kesedaran masyarakat, kekurangan tenaga pakar, ketidakseragaman perundangan wakaf. kerjasama daripada semua pihak sama ada kerajaan ataupun swasta amat dituntut dan bersama-sama berganding bahu dalam menghadapi cabaran yang dihadapi oleh institusi wakaf serta cuba menyelesaikan permasalahan yang berlaku.

Sorotan karya juga dilakukan oleh Mohd Saharudin bin Shokrani, Mohd Saifoul Zamzuri Noor, Jamal Ali dalam artikel bertajuk Tinjauan Isu-Isu Yang Membataskan Penggunaan Wakaf Dalam Pembangunan Ekonomi Ummah di Malaysia²⁴.

Fokus kajian ini adalah untuk mengkaji isu-isu awal yang menghalang pelaksanaan wakaf secara efektif dalam pembangunan ekonomi di Malaysia. Pertama, adalah masalah pentafsiran dan perbezaan pandangan di kalangan ilmuan Islam bagaimana cara mengembangkan aset wakaf. Kedua adalah masalah perundangan, dan masalah ketiga adalah masalah pentadbiran Baitul Mal yang tidak efisien dan tidak sistematik. Di Malaysia, institusi wakaf tidak berfungsi dengan baik dalam meningkatkan kesejahteraan ekonomi ummah. Institusi wakaf mampu berperanan dalam membangunkan ekonomi ummah jika masyarakat memahami dengan lebih jelas penafsiran penggunaan tanah wakaf dan matlamat ibadah wakaf. Tanggungjawab memberi penerangan adalah pihak Majlis Agama Islam Negeri, para ilmuan dan badan-badan berkaitan. Kajian ini mencadangkan beberapa perkara :

a) Institusi wakaf juga dapat membantu meningkatkan ekonomi ummah dan Majlis Agama Islam Negeri sekiranya halangan-halangan perundangan dapat dihapuskan. Ini adalah di bawah hak kerajaan negeri dan kuasa Raja dan Sultan. Ini kerana mengikut Abdul Monir Yaacob,²⁶ kecenderungan yang ada sekarang sekiranya perkara-perkara tersebut menyentuh agama Islam yang terletak di bawah hak kerajaan negeri dan menyentuh kuasa Raja atau Sultan boleh dilakukan dengan dua cara:

- i. Melalui perbincangan dan muafakat antara negeri-negeri bagi menyeragamkan urusan agama tanpa melibatkan pindaan mana-mana peruntukan undang.
- ii. Dengan cadangan dari Majlis Raja-Raja supaya diadakan suatu penyelarasan undang-undang yang terletak di bawah kuasa Raja atau Sultan.

b) Institusi wakaf juga mampu berperanan dalam membangunkan ekonomi ummah melalui pentadbiran dan pengurusan institusi wakaf yang cekap dan sistematik. Ini kerana menurut Kamarudin Ngah,²⁷ institusi wakaf dapat membangunkan ekonomi ummah sekiranya kita berjaya mewujudkan satu polisi perancangan pembangunan tanah wakaf yang seragam di seluruh negara yang bermatlamatkan guna tanah wakaf untuk masa hadapan. Antara projek dan perancangan yang boleh dijadikan contoh:

- i. Mewujudkan pangkalan data wakaf Malaysia
- ii. Skim Saham Wakaf Selangor yang dilancarkan oleh MAIS. Skim ini memudahkan umat Islam untuk mewakafkan harta, walaupun tidak berkemampuan untuk mewakafkan aset yang berbentuk kekal dan tinggi nilainya seperti tanah, rumah, bangunan dan sebagainya.
- iii. wakaf jemba seperti yang dilakukan di Kedah.

c) Kita juga mesti meletakkan institusi wakaf ke tarafnya yang sebenar berteraskan pembangunan keIslaman dengan mementingkan ciri-ciri kerohanian dan keredhaan Allah.²⁸ Ini bermaksud rancangan pembangunan tanah wakaf mestilah seimbang dari segi pembarigunan fizikal dan rohani ummah, mencakupi kebahagiaan di dunia dan kebahagiaan di akhirat.

10. KESIMPULAN

Isu dan cabaran yang dihadapi oleh institusi-institusi wakaf perlu diatasi dengan sebaik mungkin bagi memastikan harta wakaf dapat berperanan secara maksima dalam membangunkan ekonomi ummah, khususnya di Malaysia.

RUJUKAN

- Othman, M. Z. (1998). Wakaf Dari Perspektif Undang-undang Islam, Amalan dan Permasalahannya di Malaysia. *Dlm. Ahmad Ibrahim (1998). (Eds.) et. al, Al-Ahkam, Jilid, 6.*
- Mohd Saharudin bin Shakrani (2003), Tinjauan Isu-isu yang membataskan Penggunaan Wakaf Dalam Pembangunan Ekonomi Ummah di Malaysia, *Jurnal Syariah*.
- Sarimah Hanim Aman Shah (2005), Ekonomi dari Perspektif Islam, Fajar Bakti Sdn. Bhd.
- Asmak Ab Rahman (2009), dalam tulisannya yang bertajuk Peranan Wakaf Dalam Pembangunan Ekonomi Umat Islam Dan Aplikasinya Di Malaysia, *Jurnal Syariah, Jilid 17.*
- Razali Othman (2015), Institusi Wakaf Sejarah dan Amalan Masa Kini, Dewan Bahasa dan Pustaka.
- Datuk Haji Anan bin C. Mohd (2015), Pembangunan Wakaf Menerusi Pendanaan Kerajaan Dan Kerjasama Institusi Kewangan Dan Korporat : Hala Tuju, Cabaran Dan Harapan.
- Rabiatul Hasanah Mahmood, Nazifah Mustaffha, Latifa Bibi Musafar Hameed, dan Norhanizah Johari (2017), *Pengurusan Wakaf di Malaysia: Isu dan Cabaran.*
- Mohd Saharudin bin Shakrani, Mohd Saifoul Zamzuri Noor, Jamal Ali (2019), Tinjauan Isu-Isu Yang Membataskan Penggunaan Wakaf Dalam Pembangunan Ekonomi Ummah di Malaysia.
- Hamidi Abdul Ghani (2013), Saham Wakaf Menurut Perspektif Islam : ke Arah Pelaksanaannya di Negeri Kelantan, *Jurnal KIAS Bil. VIII.*
- Mujiburrahman MS (2016), *Al-Waqf : Dirasah Tatbiqiyah fi Indonesia*, *Jurnal KIAS Bil. XI/ Vol. 11.*

²² Ibid, m.s. 36 – 41.

²³ Rabiatul Hasanah Mahmood, Nazifah Mustaffha, Latifa Bibi Musafar Hameed, dan Norhanizah Johari (2017), *Pengurusan Wakaf di Malaysia: Isu dan Cabaran*

²⁴ Mohd Saharudin bin Shakrani, Mohd Saifoul Zamzuri Noor, Jamal Ali (2019), *Tinjauan Isu-Isu Yang Membataskan Penggunaan Wakaf Dalam Pembangunan Ekonomi Ummah di Malaysia.*

SHARIAH ISSUES IN SUKUK IJARAH MAWSUFAH FI AL-ZIMMAH

Alaeddine Ziouache^{*a}, Marina Abu Bakar^b, & Mirzan Mohideen Bathusa^c

^{abc}*School of Economics, Finance and Banking, College of Business, Universiti Utara Malaysia,*

Abstract

This paper aims to identify the main Shariah issues regarding Sukuk Ijarah Mawsufah Fi al- Zimmah (IMFAZ) from the academicians and the experts point of views. For the methodology part the researchers utilized a qualitative method using online interview via zoom meeting application. Data was gathered from academicians of Universiti Utara Malaysia and experts on Shariah backgrounds from Malaysia. This paper found out that there is a positive growth of *Sukuk Ijarah Mawsufah Fi al- Zimmah* in solving the shariah issues, it also revealed that the shariah advisers need to examine and review the structure of sukuk rigorously. This study also mentioned that it is necessary to eliminate all of major prohibitions that will make the sukuk void which are: Riba, Gharar, Maysir. In the practical implications part this article shed light in the potential of sukuk *Ijarah Mawsufah Fi al- Zimmah*, it will give a benefits from the discussion to the shariah advisers, shariah committees, regulating parties, Special Purpose Vehicles. This paper adds to the literature on Sukuk Ijarah Mawsufah Fi al- Zimmah especially from the Malaysian context. The paper validates the main Shariah questions regarding Sukuk Ijarah Mawsufah Fi al- Zimmah by interviewing experts and academicians from various backgrounds.

Keywords: Ijarah, Sukuk, Ijarah Mausufa Fi al-Zimma, Islamic economics studies.

1.0 INTRODUCTION

Today's sophisticated capital markets offer a broad variety of financial instruments for issuers and investors to choose from. Sukuk popularly known as Islamic certificates or securities represent one of Islamic capital market's main instrument classes. Their innovation has drawn the ire of both Islamic and conventional issuers and investors; indeed, it has the potential to become an indispensable instrument relevant to humanity as a whole. One of the most widely used structures in both domestic and foreign issuance was the lease-based sukuk (Ijarah sukuk). This is primarily due to its ease of issuances, its versatility to be adapted to more complex systems and its preference by different parties such as the issuers, investors and Shariah's scholars. The Ijarah sukuk mechanism is useful in producing returns for creditors because it can be used in the funding process in a way that makes daily payments. IMFAZ is defined as the issuance by the owner or the SPV as a party of the certificates of equal value representing the tangible asset, usufruct, or service owner which complies with certain requirements to sell the asset, usufruct or service then becomes the property of the sukuk holders.

Being an Islamic financial instrument, the issuance and trading of sukuk necessarily have to comply with Shariah principles, rulings and parameters. This ensures sukuk maintain their distinctive characteristics that differentiate them from other financial instruments that are not Shariah-compliant, such as conventional bonds and fixed-income securities. Adherence to the requirements of Shariah is essential for preserving the sanctity of sukuk that will in turn help sustain growth and expansion of the sukuk market-as sukuk meet the demand of investors and issuers looking for Shariah-compliant investment and financing. Indeed, any breach in fulfilling Shariah requirements may affect the reputation and credibility of the issuer or originator and have a negative impact on the sukuk market. This report tries to analyze some of the possible Shariah issues that arise in sukuk IMFAZ relate to the issuance of sukuk for ownership of physical assets and usufruct, bay al-sarf, asset backed vs asset based, mix of trading assets and possession (qabd) of underlying assets. Apart from that, other practical issues related to sukuk IMFAZ are also discussed in this report.

2.0 LITERATURE REVIEW

What is Sukuk?

The definition of Sukuk comes from the singular word which is sakk, but further, it can be defined in different perspectives such as linguistic, Islamic jurisprudence and in Islamic finance. From the linguistic perspective, the term sakk is said to be of Persian origin and its meaning has the concept of two things hitting one another with high impact. In the Arab literature sakk is "to strike a seal on a document." The term sakk applies generally to any written documents. A narration quoted by Imam Malik in Al-Muwatta refers to Sukuk as a document entitling its holders to some produce of the market (Sairally, B.S & et.al, 2017).

From Islamic jurisprudence perspective, scholars used the term sakk for a written document that confirms a transaction, stipulating the rights and conditions of the contracting parties. For example, a waqf, sale or lease. Whereas, from the perspective of Islamic finance, Sukuk refers in its simplest form to 'investment certificates' that entitle the holder shall have a share of ownership proportionate of Sukuk's base assets or ownership transactions along with pro-rate profits or losses related to the property, business ventures or investment activity. Unlike conventional bonds, the structuring of Sukuk requires Shariah-compliant underlying assets (Sairally, B.S & et.al, 2017). There are three organizations that have defined Sukuk in their own perspective such as AAOIFI, IFSB and SC Malaysia. AAOIFI is one of a non-profit organization that founded to uphold and promote Sharia principles for the Islamic Islamic finance business, financial institutions and the members as a whole. AAOIFI stands for the Accounting and Auditing Organization for Islamic Financial Institutions describing Sukuk as reflecting Istithmar Sukuk (Investment Sukuk) to differentiate them from shares and bonds. In its Standard 17(2)(2015) of Shariah, AAOIFI describes Sukuk as:

“Equal interest certificates containing undivided shares in the ownership of real assets, usufructs and services or resources (owned) of specific ventures or special investment activities.”

Definition of Ijarah Sukuk

Ijarah simply means that the usufruct of a specified property that will be transferred to another person from the owner (as the lessor) for the purposes of making a pre-negotiated rental payment within a defined lease period. Since the corpus of the leased property remains in the hands of the lessor, the lessor shall bear all the liabilities arising from the ownership of the property, while the lessee shall bear the liabilities relating to the use of the property. Thus all the duties and rights resulting from the contract of Ijarah will extend to an Ijarah Sukuk as Ijarah is the main contract underlying this form of Sukuk. The underlying asset in the Ijarah Sukuk system is used in a way that allows for regular payments during the funding scheme period, combined with the versatility of customizing the payment profile and the method of measuring a profit.

Ijarah Sukuk is basically a securities reflecting the leased asset ownership, a service or a usufruct that entitles the bearer of such Sukuk to the leased asset rental receivables, usufruct or services as well as the obligations arising from such asset, usufruct or services. In addition, these certificates can be transferred to other parties in the secondary market. The definition of Ijarah Sukuk from key organizations of the Islamic finance industry is elaborated as below:

Securities Commission Malaysia (SC)

According to SC Malaysia Ijarah Sukuk is certificates of equal interest indicating that the holder of a certificate of leased assets and/or usufruct and services, as well as access to the rental debts, has undivided ownership of the leased asset and/or services.

From (AAOIFI) perspective. Actually

AAOIFI has been classified Ijarah Sukuk as very important for tangible assets, usufructs, and services. In its Shariah Standard No. 17 (3/1-3/2) it describes the different forms of Ijarah Sukuk as follows: Certificate of Ownership of Usufructs of Existing Property, Certificates of Ownership of Usufructs of Described Future Assets, Certificates of Ownership of Services of a Specified Party, Certificates of Ownership of Described Future Services.

International Islamic Fiqh Academy of the Organization of Islamic Cooperation (IFA-OIC)

The IFA-OIC in its Resolution No. 137 (3/15) (2004) discusses Ijarah Sukuk as The principle of leasing bonds is

based on the concept of 'securitization' relating to issuing negotiable financial papers backed by income-generating properties. The purpose of leasing bonds is to hand over the assets and usufructs relating to the lease contract to financial papers (bonds) that can be negotiated in secondary markets. Under AAOIFI (2015) definition, it is particularly noted that Ijarah Sukuk has been classified under three categories as follow:

- i. Sukuk for the Ownership of Tangible Assets.
- ii. Sukuk for the Ownership of Usufructs.
- iii. Sukuk for the Ownership of Services.

The Differences between Sukuk and Bonds.

According Sairally, B.S and et. al (2017); Shahar, W. S, Shahar W.S.S and Jamlus, N. (2014); Advisory, S (n.d) the differences between Sukuk and conventional bonds are mentioned as below:

Key Differences	Conventional Bonds	Sukuk
Nature	Represents an IOU or the issuer's interest-bearing debt duty	Represents a proportionate keeping in <i>Shariah</i>
Issuer	The issuance of conventional bonds is not constrained in its commercial activities	Any emitter engaged in business activities allowed under <i>Shariah</i>
Investors	Non-Islamic Investors	Islamic and non-Islamic investors
Relationship between Issuer and Investor	Lending arrangement that gives investors creditor status	<i>Shariah</i> -based relationship used to build <i>Sukuk</i>
Underlying Assets	No assets required for unsecured bonds i.e there is no need for collateral backing the bond issue.	Underlying properties must meet <i>Shariah</i> requirements.
Asset-Related Expenses Status	Bond investors are not affected	<i>Sukuk</i> holders may be affected
	Represent unsecured creditors, except where particular assets support bonds.	In case of default or if the issuer faces difficulties in paying, <i>Sukuk</i> investors in asset-backed <i>Sukuk</i> have access to the money.
Return to investors	Coupon payment in interest form that reflects a percentage of the money. They equate with fixed interest, which is connoted to <i>riba</i> .	Periodic payments reflect a percentage of real income that generated from contracts of sale and partnership and also by rent that generated from contract of lease
Principal Repayment by Issuer	Return of principal on maturity is an irrevocable obligation, irrespective of whether the sponsored project was profitable	By practice, there is no fixed capital payment requirement for partnership-based <i>Sukuk</i> structures but the return of principal is assured by sale-based and lease-based structures.
Utilization of Proceeds	No specific requirement.	Proceed must be used to finance <i>Shariah</i> -compliance activities.
Tradability in the Secondary Market	Selling bonds represent sale of debt.	Selling <i>Sukuk</i> is essentially selling an asset's share, or in a project.
Pricing	Depends on the issuer's credit rating and terms and conditions.	Depends upon the <i>Sukuk</i> structure
Asset ownership	Bonds do not confer a share of ownership on the investor in the asset, project, business or joint venture they support.	<i>Sukuk</i> gives part-ownership to the investor in the properties on which the <i>Sukuk</i> is based.
Effects of costs	Holder not affected by costs related to the asset, project, business, or joint venture they support.	Costs attributable to the underlying asset impact holders.
Investment rewards and risks	Bond investors receive a regular scheduled interest charges for the bond's duration, and their principal is expected to be repaid at the maturity date of the bond.	<i>Sukuk</i> holders receive a share of profits from the underlying asset.
Issue price	Depending upon the credit worthiness of the issuer.	Depending upon the underlying asset's market value.
Issue unit	Each bond reflects a debt-share.	Each <i>Sukuk</i> stands for a share of the underlying asset.
Investment criteria	Used to finance any asset, project, business or joint venture that meets local laws.	The commodity <i>Sukuk</i> is focused on must be consistent with the sharia.

Practical Issues Relating to Ijarah Sukuk

It is vital to deliberate on some of the practical issues faced by financial institutions when issuing Sukuk. These are briefly explained below:

Pricing of the Sukuk

Up till now, as mentioned previously, LIBOR, EURIBOR or any other interest rates are used as a form of benchmark, and this has become a norm in Islamic financial institutions. However, while it is acceptable both LIBOR and EURIBOR as a benchmark, the intrinsic value of returns arises from the rentals pertaining to the leasing arrangements with originator and SPV.

For example, in the case of Ijarah Sukuk, a Shariah-compliant structure is when the Sukuk holders earn their returns

on the rent of Sukuk's properties. However, the return may not represent the underlying asset but may be the single low prevailing interest rate. This is obvious in two entirely different real assets which are supposed to have different rental yields based on the realities of the industry. Nevertheless, a similar return rate was reported, as they are used for two separate Sukuk issuances as the underlying asset. That is because the prevailing interest rate is used by both situations as a benchmark. For instance, the Sukuk holder would receive low returns based on low-interest rates in an Ijarah Sukuk, where a certain form of real estate is used as the underlying assets and despite the fact that the rent of properties rises in the particular field in which their assets are located. The returns on Sukuk thus does not represent the quality of the underlying asset; instead, it is largely dependent on the prevalent interest rate.

2.4.2 Short supply of eligible underlying assets

In a Shariah-compatible Sukuk structure, the underlying mechanism for the Sukuk emission is crucially significant. Nevertheless, the position of the grouping of assets generating a Shariah-compliant income stream is one of the challenges at present. Often, a common Ijarah Sukuk asset class is property or other tangible assets. Certain eligible Sukuk asset classes include commodities or goods and moving properties that are in compliance with Shariah. The leasing earnings from these properties would provide the Sukuk owners with cash flow returns. In addition, the obligor/originator's duty to buy back those properties ensures key repayments in due time.

One of the key impediments is the very limited number of eligible Shariah-compliant properties, which is seen as a significant obstacle in Sukuk industry development. This is one of the reasons why the industry has transferred Sukuk blended assets, with wakalah bi al-Istithmar as the main contract behind them and allows for various combinations of assets on the basis of the principle of khultah. In addition, intangible assets are being gradually used to build Sukuk. This thing gives issuers a broader range of assets and greater versatility in their choices.

2.4.3 Rate of return risk

Each Ijarah Sukuk at a fixed rate meets the rate of risk of return. Rate of return is an investment gain or loss for a given duration, which is the percentage of the investment cost. The returned risk rate has different implications both for the lender and the investor. Therefore, the magnitude of the return risk is directly proportional to The Sukuk's maturity and market risk adjustments. The longer the maturity period, for example, the greater the risk to investors. If the returns are tied to LIBOR, an increase of the benchmark rate would raise the payment obligations of the borrower in the case of the adjustable rate of Ijarah Sukuk it may be maintained or not and would become more popular if the payment ability of the obligor is strongly dependent on the earnings of a pool of fixed returned properties.

2.4.4 High transaction costs.

One of the provisions of the contract with Ijarah is that the leased properties must be able to be used for the entire lease term. The leased properties must also be managed and operated at a high cost of maintenance. Additionally, in cases of loss, injury and degradation of the leased properties, the lessor must bear the associated costs. Therefore, there will be an extra expense to cover these risks in a reasonable way. In addition, if the leased assets incur partial or total losses, or the leased assets are inconsistent with the Shariah, then the issuer or the SPV must replace the leased assets (such as the Sukuk trustee). That is also a secondary expense.

2.5 Ijarah Mawsufah Fi al-Zimmah

Ijarah al-Zimmah can be defined as the sale of future benefits for the purpose of obtaining divine cash or a court of law for the purpose of deriving whether the benefits are derived from the assets or services (Hammad, 1993). It is named Ijarah al-Zimmah because the benefit of the asset is closely related to the liability of the lender rather than the asset itself. It can also be defined as a benefit (Ijarah) that is guaranteed because the lender guarantees to provide the benefit under any circumstances (Nasar, A.M., 2009). This agreement is regarded as salam in which the subject is the benefit (Al-Manhaji, S. M., 1955). In fact, in some of the classical fiqh books, this agreement was dropped by the fuqaha in the chapter of salam.

2.5.1 Differences between Ijarah al-Zimmah and Ijarah.

The Ijarah al-Zimmah contract is not void if the rental property is damaged. If this happens, the lessor will have to replace the new asset in lieu of the damaged asset. Leasing of the benefit of the lease must be made by the lender according to the length of time the agreement has been made between the lessee. However, the Ijarah contract may be canceled if the lease benefit is impaired either before or after the benefit is delivered to the lessee.

In Ijarah al-Zimmah, the benefit does not necessarily belong to the lender at the time of the contract provided that the lender can deliver the benefit at the agreed time. While in the Ijarah contract, Ijarah benefits must be owned by the lender at when the contract made (Ghuddah, D. A., 2007).

There is no *khiyar al-'ayb* in Ijarah al-Zimmah contract, whereas this *khiyar* occurs in the Ijarah or Ijarah wa iqtina' contract.

If the Ijarah al-Zimmah contract, if it involves the delivery of an asset, then the cost of packaging the asset must be borne by the lessee. In contrast to the Ijarah contract, the cost of the packaging was borne by the lender (Ghuddah, D. A., 2007).

A detailed description is not required as the benefits that are the subject of the contract do not conflict with the specifications agreed until the deal is concluded. The Muslim scholars have illustrated this criterion by giving detailed examples of clothing when ordering clothes with tailors or buildings that need repair. In these examples, it is sufficient to provide details on the type of dress booking required for the tailor (Ghuddah, D. A., 2007).

The use of asset benefits does not occur after the IMFAZ contract is made, but it does happen in the future. On the other hand, the benefits of assets in the Ijarah contract could be deferred or determined at a later date. This refers to views other than the Shafi'i sect, in which they prohibit Ijarah to be backed up in the future (Al-Qasimi, B.H., 2009).

2.6 Shariah Issues Relating to Sukuk IMFAZ.

Below are some of the Shariah issues related to sukuk IMFAZ:

2.6.1 Issuance for ownership of physical assets

Here, the subject of IMFAZ refers to the physical assets. Sukuk represents the ownership of the physical assets. However, in Sukuk IMFAZ, it is difficult to determine the ownership of the physical assets involved. Because of the uncertainty in determining which item is represented by the Sukuk issued by the lessor, it makes this type of Sukuk possibly illegal in Shariah. Basically, IMFAZ is characterized by two distinguishing natures: the definitive nature of the benefit to be offered by the lessor, and the uncertain nature of the item containing the benefit. These two essential natures of IMFAZ allow the lessor to offer any item as long as it contains the benefit agreed upon in the Ijarah contract and serves the purposes of Ijarah.

These items which contain the *mawsufah fi al-zimmah* benefit may carry different traits and qualities, but somehow all serve similar purposes. As long as they enable the lessee to benefit from them, there will be no issue of the lessor having to replace the item with a new one because the uncertainty in the item does not affect the contract if the benefit is clearly identified. This does not include the uncertainty of whether the item will be delivered on time and/or will meet the actual description when delivered. Thus, as far as Sukuk that represent the ownership of the item in IMFAZ is concerned, this uncertainty on behalf of the item which contains the benefit undoubtedly leads to the impossibility in determining which item is represented by the Sukuk issued by the lessor, making this type of Sukuk possibly illegal.

Some scholars prohibit the issuance and trading of Sukuk for the ownership of assets that are the subject of usufruct meeting certain specifications (*mawsufah fi al-zimmah*). This is based on the deliberation that the asset can offer by the lessor to the lessee for the aim of providing the usufruct is unknown—because the nature of the usufruct which is the subject of a IMFAZ contract is not associated with a particular tangible asset, opposite to the lease of a particular asset. Rather, it is an undertaking for which the lessor assumes liability, and he will fulfill his responsibility, in accordance with the Shariah, by supplying any tangible asset that provides usufruct meeting the specifications in the contract.

The majority contemporary scholars prohibit the secondary trading of these Sukuk before the physical assets that provide the usufruct—which is what the Sukuk holders have purchased are completed or more than half-completed. This is because the contracts that cover these assets usually include *istisna'* or IMFAZ contracts being combined, and when the Sukuk are sold they are denoted by cash until they have been converted to physical assets (or until most of their value is converted). Thus, they are covered by the Shariah rules relating to *sarf* as their sale would be an exchange of cash for cash.

In addition, it has also been identified that a lease of usufruct in IMFAZ leads to sale of a debt for a debt as both the physical asset and the usufruct are, at the time of the Sukuk issuance, no more than just debts. AAOIFI Shariah

Standard No. 17 (5/2/4) states the following on this issue:

“It is permissible, immediately upon issue and up to the date of maturity, but after the passing of ownership of the assets to the holders of the Sukuk, to trade in Sukuk that represent ownership of existing leased assets or assets to be leased on promise.”

Thus, it is clear that the standard allows for the trading of the Sukuk this step will do only after the transferring of the possession of the assets to the Sukuk holders. Although a majority of the Shariah scholars are agreeable to the supplying and commerce of the Ijarah Sukuk in the secondary market, some scholars disagree with this unless the buy-back value is based on the market price.

2.6.2 Issuance for ownership of usufruct

In this case, the Sukuk subject is the usufruct of certain specifications which are assigned to the issuer's liability. Example of usufruct is the right to stay in a hotel which is still under construction for a specific period. Therefore, the details of the physical asset that provides the usufruct must be clearly and concisely described to avoid any upcoming disputes. Failure in providing the specifications that were assigned to the issuer's liability will lead to gharar fahish. For example, such details about the asset should be provided: the type or size of the hotel room, the amenities offered in the room, the services available in the hotel, the location plan of the hotel and the room, and other important information.

2.6.3 Bay al-sarf

The issue of bay al-sarf is relevant in the trading of Sukuk. Sukuk represent ownership of the underlying assets; their trading is interpreted as direct exchange of their underlying assets. Thus, if currency or cash is the underlying asset of Sukuk at any stage and the Sukuk are traded for a cash price then their trading would fall under the scope of bay al-sarf at that specific stage. In the case of secondary trading of Sukuk IMFAZ, when the Sukuk is sold they will be denoted in cash before they are converted to real assets (or until most of their value is converted). They are therefore triggered by the issue of bay al-sarf that is related to Shariah laws. This is because their selling will be an exchange of cash for cash.

2.6.4 Mix of trading assets

Most of the Sukuk nowadays do not merely consist of one type of underlying assets. Usually, the underlying assets of Sukuk are formed by combining various types of assets such as (commodities, land and buildings) which stated under tangible assets and (usufructs, services and rights) which supposed to be intangible assets. From another aspect, they may stated in the form of credit or assets (ribawi assets) and usufruct, products, rights and services (non-ribawi assets). Due to the fact that their underlying assets are neither completely non-ribawi nor completely ribawi, the Shariah ruling for their trading is quite complicated. This issue has become a debating point of difference among modern-day Shariah scholars.

2.6.5 Possession (Qabd) of Underlying Assets

As compared to physical possession (qabd haqiqi or hissi), constructive possession (qabd hukmi or ma'nawi) is more real in the context of Sukuk. Constructive possession of an underlying asset of Sukuk is achieved when the ownership titles, rights and liabilities of the underlying asset are transferred to the subscribers of Sukuk. Similarly, constructive possession of proceeds of Sukuk is considered to be achieved when the subscription amount of Sukuk is collected by the issuer of Sukuk.

However, there are various issues and aspects arising from how Sukuk are structured that are strongly relevant to the discussion of constructive possession. For instance, the issue of possession becomes quite relevant is when the Sukuk are built on cash, or backed by money. The Sukuk investors have in asset backed Sukuk unrestricted ownership of the underlying assets of Sukuk which is established via true sale, therefore constructive possession seems to be valid in such of type Sukuk. On the contrary, in the Sukuk that are asset-based, the Sukuk holders only enjoy restricted owning the underlying properties of Sukuk. For instance, they do not have the authority to make use of the underlying properties in case of default.

2.6.6 Rental payment structure, fixed rate or floating rate

Initially, fixed rate Ijarah was seen to be the only Shariah-compliant rental payment structure. Unfortunately, fixed rate Sukuk tend to face several market risks. To address this issue, the floating rate rental payment structure was introduced, with a precondition that it must be based on a certain formula and it has to be fixed for a certain period and agreed upfront. Finally, to match the market requirement of having a floating rate Sukuk on the one hand the Shariah requirement of having fixed rate rentals on the other, a solution was found which was to base the Ijarah Sukuk on a master Ijarah agreement with several subordinate Ijarah agreements. In the subordinate Ijarah contract.

The rentals can be revised semi-annually in accordance with the market benchmark. This method ensures that the rent can be fixed for six months while it floats in accordance with the market benchmark such as LIBOR or EURIBOR at the same time. However, it is noteworthy that while it is permissible to use LIBOR and EURIBOR as a benchmark, the returns to the Ijarah Sukuk holders are not reflective of the rental of the underlying asset; instead, it reflects the prevalent interest rates which are used as the benchmark.

2.6.7 The issue of expenditures which defy the maqasid

In the case of IMFAZ, the lessee is the sole responsible for maintaining expenditures (ordinary maintenance and repairs) and it defies the maqasid shariah. The master lease agreement stipulates that the 'aqidain' (contracting parties) agree to the point that "major maintenance" costs will be borne by the lessor but the true of the matter is, there is nothing in the account for "major maintenance" due to the amount of rental payment by the lessor into the transaction account is defined in the contract as the amount that is equal to the amount of periodic distribution to Sukuk holders from the transaction account and it goes on saying that the first priority in distribution from transaction account is given to the Sukuk holders. Ultimately, there is nothing in the transaction account that could cater 'major maintenance'. In short, the lessor is the prime party to bear all costs incurred and not the lessee.

3.0 METHODOLOGY

3.1 Development of interview questions

In this research the primary method of data collection is the semi-structured online interviews with the main informants. According to Creswell (2007), Merriam (2009) and Yin (2014), this method offers an opportunity for the researcher to discuss issues under review, explain claims, check for additional details and capture the perception of an opportunity or an event for an individual. The interviews conducted for the Shariah contexts with specific participants help the researcher to obtain dense and comprehensive knowledge about the issues and solutions. This also helps the researcher to collect the information in deep about the relevant skills and knowledge to perform the answers from the experts and academicians of Shariah backgrounds. The input from the Shariah academics and experts is especially useful in determining the issues and solutions. A pre-test interview question was circulated to one academic at the University Utara Malaysia in conjunction with the analysis undertaken to gain academic opinion interview guide on the structure and quality of the research instruments. It is also to get feedback on which questions work well, and which questions sound incomplete or outside the study meaning, and if the questions work well. Following comments from the academician, the real interview questions were amended accordingly.

3.2 Profiles of participants

Out of the seven scholars and experts who contacted via email and mobile, only three were able to participate. An academic delegate, University Utara Malaysia was also part of the interviewed respondents in order to get perspective from the academic's point of view.

3.3 Data gathering and analysis

The data was gathered through virtual interview meeting using WebEx and face to face meeting with the both academician and expert. The total of ten questions that related to the Sukuk was given to the academician and expert to answer. Data was analysed based on the Shariah issues of Sukuk IMFAZ. Comparative study of the academicians and the experts they serve. Certain related important concepts were established to help better clarify the criteria of Sukuk IMFAZ to solve Shariah problems effectively.

3.4 Ensuring quality and rigor in qualitative study

This case study has using a data triangulation technique that basically seeks to use multiple evidence sources to enhance the precision of the results. Merriam's (2009) practice of data triangulation emphasized such triangulation

is a well-known "internal validity improvement strategy." One of the strategies to boost the validity of the study findings can also be the use of multiple data sources (Denzin and Lincoln, 2008). Two approaches are used to answer research questions in accordance with the data triangulation technique, including semi-structured face-to-face interviews and interviews with virtual meetings. The respondents were usually staff involved directly in the field under review.

However, the multi-case study pattern that helps the researcher to collect the data from various sources and from two scholars and Shariah experts for this analysis. The data triangulation was also achieved in the current study through interviews with participants at the same organizational level as the lecturer at the University Utara Malaysia, who have the awareness of Sukuk IMFAZ's Shariah issues. In addition, the triangulation of data was further enhanced with various sources of proof, such as the authority's guidelines for administering such Both the organizations under review and the websites. Review of test paper substantiates the results of the interviews. This happens if what the respondent tells the investigator about an object in the interview that can be checked or confirmed with the information in the relevant phenomenon documents (Merriam, 2009). For example, in this study, findings from the interviews were checked later on. Validation of data was then achieved by respondents through the "member check" procedure. According to Silverman (2004) and Merriam (2009), member tests or the authentication of respondents is a reliability technique. According to Creswell (2007), his method includes data collection, interpretation, interpretation and conclusions from case informants in order to provide input on the analysis of the researcher. For this analysis, member tests are carried out as the participants through the interviews participated in the semi-structured interviews were asked to comment on the solution to the problems proposed in the study.

Peer review is the other technique for exchanging ideas on the build validity qualitative data definition and interpretation of the study, processes, and study cycle. According to Merriam (2009), such practice it is when the researcher took part in the self-help community as a way of gaining consensus legitimacy among respected and competent colleagues. The informal discussions with colleagues who also do qualitative research analyzes in various areas of study enabled the author gain emotional and intellectual support among peers addressed some of the stages of difficulties faced during the study period.

4.0 FINDINGS AND DISCUSSION

The Shariah Analysis Of Ijarah Mawsufah Fi Al-Zimmah. The following section will discuss briefly the Shariah issues related to sukuk IMFAZ:

4.1 The Ownership of Physical Assets

The subject of IMFAZ refers to the physical assets. Sukuk represents the ownership of the physical assets. However, in IMFAZ it is difficult to determine the ownership of the physical assets involved because of the issue of gharar (uncertainty) in determining which item is represented by the sukuk issued by the lessor, it makes this type of Sukuk possibly illegal and void in Shariah. Gharar literally means danger, uncertainty, fraud, deception or peril. Technically, it refers to the three main concepts, namely; uncertainty, ignorance and being unknown. Gharar due to the non-existence of the subject matter or not having control over the subject matter. This is known in the conventional modern terms settlement risk or counterparty risk where the seller, for example, is not in a position to hand over the subject matter to the buyer. Ibn 'Abbas reported the Prophet (PBUH) to have said:

“He who buys food grain should not sell it until he has taken possession of it”
(Al-Bukhari, hadith no. 2136).

In the context of Sukuk, the prohibition of gharar is founded on the rule of justice and fair dealings. This is because the occurrence of gharar in any transaction may result in oppression or injustice, and the loss of properties to one or even both of the parties. It can also violate the law of mutual consent if the consent of a party to the transaction is due to their insufficient knowledge or access to material information. Due to lack of knowledge, the result of the transaction is not transparent to the parties; thus, it exposes them to unnecessary risk in business transactions.

According to the above hadith, the key reason for the prohibition of gharar is to prevent potential conflicts. If the parties concerned are not fully aware of any material contract information and are not clear, they may be engaged in unexpected financial responsibility and commitment. This might of course lead to disagreements between the parties as to the relevant and expected effects of the contracts concluded. Nevertheless, it should be noted that only major gharar, or gharar fahish, which relates to the contract's essential and material details, would make the agreement void. Minor gharar (gharar yasir) or inevitable gharar, due to the complexity of the subject matter and

the unlikely possibility of doing serious harm to one of the parties, does not affect the validity of the contract.

Sukuk IMFAZ is the Sukuk that is based on Ijarah, where the Lessor will lease to the second party of the contract which is the Lessee, and the second party will lease from the owner which is the lessor the asset for the Ijarah period of time at the related Ijarah payments for each Ijarah payment period. IMFAZ is a supporting contract in Sukuk Ijarah where it gives right to lessor to get advance rental payment [2]. Generally, IMFAZ is characterized by two distinguishing natures: the definitive nature of the benefit to be offered by the lessor, and the uncertain nature of the item containing the benefit. These two essential natures of IMFAZ allow the lessor to offer any item as long as it contains the benefit agreed upon in the ijarah contract and serves the purposes of ijarah. These items which contain the *mawsufah fi al-zimmah* benefit may carry different traits and qualities, but somehow all serve similar purposes. As long as they enable the lessee to benefit from them, there will be no issue of the lessor having to replace the item with a new one because the uncertainty in the item does not affect the contract if the benefit is clearly identified. This does not include the uncertainty of whether the item will be delivered on time and/or will meet the actual description when delivered. Thus, as far as Sukuk that represent the ownership of the item in IMFAZ is concerned, this uncertainty on behalf of the item which contains the benefit undoubtedly leads to the impossibility in determining which item is represented by the Sukuk issued by the lessor, making this type of Sukuk possibly illegal.

Due to the non-existence of the asset for the usufruct, the elements of *gharar* would exist in the contract and automatically invalidate the contract according to Islamic perspective. Dr. Nazih Hammad is one of the staunch critics of IMFAZ due to the usufructs in this contract are not associated with a particular tangible asset and it is just a debt which the lessor is liable. Furthermore, he associated his opinion with the classical Muslim scholars such as Sarakshi and Shawkani to support his viewpoint (Hammad, D. N., 2010). However, the majority of contemporary jurists are in favour of IMFAZ and both International Fiqh Academy as well as AAOIFI have certified and validated it in their resolutions. Some scholars prohibit the issuance and trading of Sukuk for the ownership of assets that are the subject of usufruct meeting certain specifications (*mawsufah fi al-zimmah*). This is based on the deliberation that the asset the lessor can offer to the lessee to provide the usufruct is unknown—because the nature of the usufruct which is the subject of an IMFAZ contract is not associated with a particular tangible asset, opposite to the lease of a particular asset. Rather, it is an undertaking for which the lessor assumes liability, and he will fulfil his responsibility, in accordance with the Shariah, by supplying any tangible asset that provides usufruct meeting the specifications in the contract.

Classical scholars have two different opinion with regards to the ownership of physical assets (the subject of IMFAZ). Hanafi school of thoughts prohibited the lease of an asset of certain specifications that the lessor undertakes to provide for leasing. This is because according to them, one of the conditions for the validity of a lease is that the usufruct must be attached to a particular asset. However, other scholars like Maliki, Shafi'i and Hanbali schools of thought agreed that the leases are valid even though they differ about whether the entire rental fee needs to be paid upfront at the contract session in order to make the contract valid (Bouheraoua et. al, 2012). The majority contemporary scholars prohibit the secondary trading of these Sukuk before the physical assets that provide the usufruct—which is what the Sukuk holders have purchased are completed or more than half-completed. This is because the contracts that cover these assets usually include *istisna'* or IMFAZ contracts being combined, and when the Sukuk are sold they are denoted by cash until they have been converted to physical assets (or until most of their value is converted). Thus, they are covered by the Shariah rules relating to *sarf* as their sale would be an exchange of cash for cash.

In addition, it has also been identified that a lease of usufruct in IMFAZ leads to sale of a debt for a debt as both the physical asset and the usufruct are, at the time of the Sukuk issuance, no more than just debts. AAOIFI Shariah Standard No. 17 (5/2/4) states the following on this issue:

“It is permissible, immediately upon issue and up to the date of maturity, but after the passing of ownership of the assets to the holders of the Sukuk, to trade in Sukuk that represent ownership of existing leased assets or assets to be leased on promise.”

Thus, it is clear that the standard allows for the commercialism of the Sukuk only after the transferring of the possession of the goods to the Sukuk holders. Although a majority of the Shariah scholars are conformable to the issuance and commerce of the ijarah Sukuk in the alternate market, some scholars disagree with this unless the buy-back value is based on the market price.

4.2 The Ownership of Usufruct

The Sukuk subject is the usufruct of certain specifications which are assigned to the issuer's liability. Example of usufruct is the right to stay in a hotel which is still under construction for a specific period. Therefore, the details of the physical asset that provides the usufruct must be clearly and concisely described to avoid any upcoming disputes. Failure in providing the specifications that were assigned to the issuer's liability will lead to major gharar (gharar fahish). For example, such details about the asset should be provided: the type or size of the hotel room, the amenities offered in the room, the services available in the hotel, the location plan of the hotel and the room, and other important information.

The issue arises when Ijarah contract in IMFAZ particularly the usufruct must be attached to a tangible asset. It cannot simply be executed without the existence of the asset. It is null and void according to Hanafi school of thought. The majority of Muslim schools are in favour of this IMFAZ except in the case of payment, whether it should be upfront or delay. According to the Shafii and Maliki school, the payment has to be upfront but according to Hanbali school, the payment can be delayed as long as the IMFAZ is not using salam in the contract. If the salam contract is being used, then the payment has to be made upfront and cannot be made delayed as to avoid riba' (usury).

Some scholars like Al-Qurrah Daghi and also the AAOIFI Shariah Standard have prohibited the trading of Sukuk for ownership of usufruct that is the subject of IMFAZ. AAOIFI Shariah Standard No. 17 (5/2/8) on investment sukuk stated that; "It is not permissible to trade in certificates of ownership of usufructs of a described asset before the asset from which usufruct is to be made available is ascertained, except by observing the rules of disposal of receivables. When the asset is ascertained, trading in Sukuk of usufructs of such asset may take place". Al-Qurrah Daghi concluded that the strongest opinion regarding the sale and purchase of sukuk of this type is that they are only permissible after the issuer has converted the funds raised by the subscription (what was paid for the Sukuk), or most of them, into a lease of particular assets. Before that happens, it is not permissible to trade them because they remain cash that has not been converted, completely or mostly, into particular leased assets or realised usufruct "(Al-Qurrah Daghi, 2004).

Other than that, other contemporary scholars like Hammad, Abdul Sattar Abu Ghuddah, Hussein Hamed Hassan and Kahf permitted to trade such Sukuk (Hammad, 2010; Hassan, H. H., n.d.; Abu Ghuddah, A. S., n.d.; Kahf, 2011). The basis for the view is that the trading of Sukuk for the ownership of the usufruct in forward leases is a form of hawalah (transfer) of responsibility for fulfilling the liability; it is not a sale of the same usufruct that is mawsufah fi al-zimmah. Therefore, the usufruct that associated with a particular tangible asset must be meticulously described and narrated in full identification. To conclude, the contemporary jurists are in favour of this Sukuk but majority of them including AAOIFI are not happy with it and hold it as impermissible.

4.3 Bay al-Sarf

Sarf is an Arabic word that means change or exchange. The term bay al-sarf means selling or exchanging currencies with one another, they can be either of the same genus or of different genus. Moreover, currencies of different countries should be treated as different species, so inequality in their exchange is allowed, but without any deferment. This is the view stated by the IEA-OIC (2000) in its Resolution No. 21 (9/3) dated October 1986; AAOIFI 2015 in its Shariah Standard No. 1; and IFC-MWL (1982) in its 6th Resolution of the 5th session. The issue of bay al-sarf is relevant in the trading of Sukuk. Sukuk represent ownership of the underlying assets; their trading is interpreted as direct exchange of their underlying assets. Thus, if currency or cash is the underlying asset of Sukuk at any stage and the Sukuk are traded for a cash price then their trading would fall under the scope of bay al-sarf at that specific stage. That is why the IFA-OIC, in its Resolution No. 30 (5/4) dated February 1988, resolved regarding mudarabah sukuk that if mudarabah capital is still in the form of cash after closing of subscription, the trading of such sukuk for cash would be considered exchange of money for money; thus the conditions of currency exchange would be observed. The same ruling for other sukuk having cash as underlying assets is mentioned in Resolution No. 178 (4/19) dated April 2009.

Likewise, AAOIFI (2015) in Shariah Standard No. 17 (5/2/1) mentions that just after the closing of subscription and before starting business activity or an underlying project, if the assets of sukuk are in the form of cash, then the conditions of bay al-sarf would be applied in the trading of such sukuk. Similarly, when liquidation of sukuk is completed and the assets of sukuk are in the form of cash, the same ruling of bay al-sarf would be applied. In view of this, it can be construed that when the asset of sukuk is in the form of cash at any stage or point in time, their trading is subject to the rules of bay al-sarf. For sukuk IMFAZ, [1] advised that it is vital to pay attention to the status of the sukuk involved. For example, if in Ijarah contract, the assets involved are like buildings, the issue that must be considered is what is the status of the sukuk when the investors invested for buildings to rent them? Is it

debt or is it representing the assets? It is also worth mentioned, that the status can change from time to time. Let's say the delivery starts from 1 September 2020, it can be said that it is representing Ijarah now, but later, it is representing usufruct. Therefore, after the investors got the usufruct, they can change it in premium [1].

4.4 Possession (Qabd) of Underlying Assets

Basically, there are two types of possession (qabd) of underlying assets in Sukuk; physical possession (qabd haqiqi or hissi) and constructive possession (qabd hukmi or ma'nawi). For asset-based Sukuk like IMFAZ, the physical possession is more real in this context. The issue of possession becomes quite relevant as it is said that sukuk holders only enjoy restricted ownership of the underlying assets. Mutual delivery and possession of counter values by transferring ownership of those counter values to the counter parties is the ultimate objective of an exchange contract. Thus, taking possession of the underlying asset of Sukuk another vital element in such type of transactions. The word qabd means "to take something". Taqabud is another term that adds a bilateral connotation of taking possession mutually by both sides of the exchange, The SAC of SC Malaysia (2006) considers possession as taking ownership and control over something through an exchange contract. AAOIFI (2015) in Shariah Standard No. 18 (2) defines possession as:

“Possession is the assembly of a thing or what takes its rule, based on the necessities of customary activity”

In the discipline of Islamic law of contracts, qabd is defined as an enablement, relinquishment and waiving any hindrance according to custom and genuine practice (Al-Kasani, 1986). From the preceding definitions given, it is evident that the notion of taking possession is fundamentally based on the quality of the physical object and on the customary activity of the people. This is also stated in the Resolution No. 53 (4/6) dated March 1990 by the IFA-OIC, AAOIFI (2015) in Shariah Standard No. 18 and the SAC of SC Malaysia (2006). The issue of bay al-sarf is relevant in the trading of sukuk. Sukuk represent ownership of the underlying assets; their trading is interpreted as direct exchange of their underlying assets. Thus, if currency or cash is the underlying asset of Sukuk at any stage and the Sukuk are traded for a cash price then their trading would fall under the scope of bay al-sarf at that specific stage. In the case of secondary trading of Sukuk IMFAZ, when the Sukuk is sold they will be denoted in cash before they are converted to real assets (or until most of their value is converted). They are therefore triggered by the issue of bay al-sarf that is related to Shariah laws. This is because their selling will be an exchange of cash for cash.

With this regard, [2] viewed that obviously qabd haqiqi belongs to lessor but qabd ma'nawi can be transferred to lessee. In the issue of incomplete projects, lessee should be responsible to the losses in the contract [2]. [1] stressed out that IMFAZ is different with conventional bonds in the sense that in asset based like IMFAZ, the assets involved are the income from the building, from the businesses or from the obligor, where actually there are “real possession” in the assets. On the contrary, this is different when it comes to conventional bonds, because the income came from the interest were charged from the assets. Hence, the obligor payed the rental payment, therefore the obligor has the right of benefits over the assets (huquq al-intifa'). As compared to physical possession (qabd haqiqi or hissi), constructive possession (qabd hukmi or ma'nawi) is more real in the context of Sukuk. Constructive possession of an underlying asset of Sukuk is achieved when the ownership titles, rights and liabilities of the underlying asset are transferred to the subscribers of Sukuk. Similarly, constructive possession of proceeds of Sukuk is considered to be achieved when the subscription amount of Sukuk is collected by the issuer of Sukuk.

However, there are various issues and aspects arising from how Sukuk are structured that are strongly relevant to the discussion of constructive possession. For instance, the issue of possession becomes quite relevant is when the Sukuk are asset-based or asset-backed. In asset-backed Sukuk, the Sukuk holders have unrestricted ownership of the underlying assets of Sukuk which is established via true sale, therefore constructive possession seems to be valid in such of type Sukuk. On the contrary, in the Sukuk that are asset-based, the Sukuk holders only enjoy restricted ownership of the underlying assets of Sukuk. For instance, they do when default case occurs, they will not have the right of access to the underlying properties.

4.5 Mix of Trading Assets

Most of the Sukuk nowadays don't merely consist of one type of underlying assets. Usually, the underlying assets of Sukuk are formed by combining various types of assets such as touchable assets (like commodities, land and structures) and unidentifiable assets (like usufructs, services and rights). From another aspect, they may seem like currency or assets (ribawi assets) and products, usufruct, rights and services (non-ribawi assets). Due to the fact that their underlying assets are neither completely non-ribawi nor completely ribawi, the Shariah ruling for their trading is quite complicated. This issue has become a controversial point of difference among contemporary Shariah

scholars.

AAOIFI (2015) in Shariah Standard No. 17 (5/2/1) only revealed the content of tradability of sukuk that have an individual type of asset. For example, it highlights that when the implicit assets belong to the touchable assets, usufructs or services, they can be listed at any price. [2] is on the opinion of the permissibility of mix trading assets. According to him, mix of trading asset is permissible with the condition that the assets should be clearly spell out in the contract to avoid gharar. If the lessee agrees on the asset offered by the lessor, then he can enter into Ijarah contract or Sukuk IMFAZ. For [1], he viewed that normally for sukuk ijarah, the assets must be something that can be rented possibly as the underlying assets. As for beneficial ownership, the process involved to change into beneficial ownership is very costly. Normally, the Government will not sell the asset. However, the issue arises when the Government sell the asset, it will be in a form of fixed or real sale. From here it will trigger the issue of qard, that is not recognized in Islamic law. Hence, in order to ensure that the transfer of beneficial ownership really happened the government must obtain the permission from the Cabinet, and it isn't something easy to get an approval from the Cabinet.

4.6 Rental Payment Structure, Fixed Rate or Floating Rate

Initially, fixed rate ijarah was seen to be the only Shariah-compliant rental payment structure. Unfortunately, fixed rate Sukuk tend to face several market risks. To address this issue, the floating rate rental payment structure was introduced, with a precondition that it must be based on a certain formula and it has to be fixed for a certain period and agreed upfront. Finally, to match the market requirement of having a floating rate Sukuk on the one hand the Shariah requirement of having fixed rate rentals on the other, a solution was found which was to base the ijarah Sukuk on a master ijarah agreement with several subordinate ijarah agreements in the subordinate ijarah contract. The rentals can be revised semi-annually in accordance with the market benchmark. This method ensures that the rent can be fixed for six months while it floats in accordance with the market benchmark such as LIBOR or EURIBOR at the same time. However, it is noteworthy that while it is permissible to use LIBOR and EURIBOR as a benchmark, the returns to the ijarah Sukuk holders are not reflective of the rental of the underlying asset; instead, it reflects the prevalent interest rates which are used as the benchmark.

The main concept in sukuk IMFAZ is Ijarah; the lessor leases the underlying asset to lessee. Because of this, it should follow the basic elements of contract; 'aqad, subject matter, contracting parties, price/rental. For IMFAZ, it is just a supporting contract to justify the rental return for project/asset under construction in contract Ijarah [2]. For [1], he opined that all of the elements of Ijarah must be fulfilled in the issue of rental payment. The two contracting parties upon agreeing the subject matter of the contract must follow the rules of thumb for Ijarah. For example, when is the time the lessee and lessor agreed to make payment, is it now or later? If the lessor permits the lessee to pay later, then it is permissible in Shariah. However, in the case of open delivery, the lessee has the right to reject the offer.

4.7 The Issue of Expenditures Which Defy the Maqasid Shariah

In the case of IMFAZ, the lessee is the sole responsible for maintaining expenditures (ordinary maintenance and repairs) and it defies the Maqasid Shariah. The master lease agreement stipulates that the 'aqidain' (contracting parties) agree to the point that "major maintenance" costs will be borne by the lessor but the true of the matter is, there is nothing in the account for "major maintenance" due to the amount of rental payment by the lessor into the transaction account is defined in the contract as the amount that is equal to the amount of periodic distribution to Sukuk holders from the transaction account and it goes on saying that the first priority in distribution from transaction account is given to the Sukuk holders. Ultimately, there is nothing in the transaction account that could cater 'major maintenance'. In short, the lessor is the prime party to bear all costs incurred and not the lessee.

4.8 Sukuk Default

Capital Intelligence (2016) considers a default to have occurred in three major situations. Firstly, when an issuer fails to pay a material sum of principal and/or interest on a financial obligation in accordance with its terms. Secondly, when an issuer files for bankruptcy or similar protection from creditors-unless there is reason to believe that debt service payments will continue to be made in a timely manner. Lastly, when an issuer restructures (reorganises), reschedules, exchanges or in some other way renegotiates a debt instrument. For the third scenario, the following things apply:

1. There is an adverse change to the terms of the original debt agreement; and
2. The renegotiation or exchange is considered by Capital Intelligence to be distressed or coercive.

Adverse changes to the terms of the original debt agreement may include the following:

- A reduction in the principal amount or coupon/interest rate;
- An extension of the maturity date or loan tenure;
- A reduction in seniority or a substantial weakening of covenants;
- A cash tender for less than par;
- A decrease in the frequency of payments (e.g. from amortising to bullet payments); and
- Swapping debt for equity or hybrid instruments.

While the theoretical debate around the nature of as well as the Shariah justification for asset-based versus asset-backed sukuk is still ongoing, many examples of actual and near sukuk default highlight that the touchstone to distinguish between these two types is the scenario of default. The different treatment of these sukuk in the case of default is the result of the nature of asset ownership that sukuk holders have. Most of the sukuk issued so far are asset-based which only give the right of fixed payment to sukuk holders and the return does not depend on the performance of the assets. Since there is no direct link between the sukuk certificate and the underlying assets, the sukuk holders do not in case of default have recourse to the assets. One of the rationales behind issuing asset-based sukuk is to obtain a higher rating since these sukuk are linked to the credit worthiness of the originator and not to the physical asset on which sukuk are based.

The default scenario of an asset-backed sukuk is different. Since the ownership of asset has been, in most cases, legally transferred to sukuk holders in an asset-backed sukuk, they have the right of recourse against the asset itself upon default. So, the nature of asset sale is different in the two types of sukuk which leads to a different treatment of the sukuk holders when default occurs. Consequently, asset-backed sukuk may offer more security and proprietary rights to its owners—the underlying asset of such sukuk could ideally continue to perform regardless of the originator's financial distress, thus sukuk holders should be able to liquidate the asset if they wish. Conversely, if the asset underperforms (although the issuer may not be in financial distress) then the sukuk would pose higher risks to sukuk holders. In spite of these features, asset-backed sukuk are not common due to many reasons: the costs of legal transfer of ownership, tend to be very high; sukuk holders do not want to take on the actual risk of the asset and prefer to rely on the risk of the originator itself; and there are certain other legal challenges like negative covenants (which restrict specific activities by the issuer unless agreed to by the sukuk holders), and restrictions on foreign ownership that make asset-backed sukuk less preferable.

It can be summarized that Sukuk IMFAZ falls under the category of asset-based Sukuk. In an asset-based Sukuk structure, the transaction in the asset results in a transferring income rights to Sukuk investors whilst the legal title is retained by the obligor. In an asset-based Sukuk, the presence of the asset is for the purpose of Shariah fulfilment rather than to serve as a source of profit and capital payments to Sukuk holders. There's no "true sell" the underlying asset by the obligor to the SPV and thus no transfer of legal title as well as no establishment of legal owning the underlying asset to Sukuk holders. Sukuk holders only have beneficial ownership in the asset, with limited risks and rewards of ownership being transferred to them. Through a number of credit enhancement features (e.g. purchase undertaking, liquidity facility), the recourse of Sukuk holders is not to the asset but to the obligor (the entity having the obligation to redeem the Sukuk). If the obligor defaults, the Sukuk holders will only have a limited right of disposal because they will be required to sell the asset back to the obligor. Credit risk assessment will be directed towards the obligor and not on the asset. In the event of default, [2] also told that since sukuk IMFZ contract involves forward or advance rental payment, if the project is incomplete or leave abandoned, the payment should be refund to lessee due to inexistence of ijarah asset. In the context of Malaysia, it is not apparent to have problems of sukuk default. However, in other countries like Dubai, like in the case of Dana Gas, some of the scholars have declared that the contracts are not following the Shariah-compliance aspects for mudharabah and musharakah. Therefore, in this case, the parties don't necessarily need to pay for the profit [1].

5.0 SUGGESTIONS AND FUTURE RESEARCH.

5.1 Suggestion

Sukuk IMFAZ introduced successfully in several nations. There is a significant growth of this form of Sukuk in solving the Shariah problems, having to go back to the basis or essence of the IMFAZ contract, the foundations etc, in order to prevent conflicts between contracting parties. Of course, when we talk about Shariah there's a diversity of views among the scholars. There is therefore a need to look for standardization to help tackle the Shariah issues in IMFAZ which will contribute to the growth of this form of Sukuk or even modern, specific Sukuk structure involving IMFAZ. Additionally, the Shariah advisors need to rigorously analyze and study Sukuk's framework in finding the best solution to avoid the contentious issues as it has to do with halal and haram. For make standardization the secret is moderation. The research found that removing all major prohibitions that would make

the Sukuk void, which are: Riba, Gharar, Maysir, is necessary. In addition, sustainable and responsible investment Sukuk Got government incentives for this form of Sukuk, since one of the problems is restricted physical asset availability in Ijarah.

5.2 Future Research

To make the implementation of Sukuk IMFAZ more need to be done through the use of technology, as it helps to interact effectively among the parties. Innovation may also focus on intangible assets or usufructs such as service rights, airtime, travel rights, and etc. Innovation affecting multiple industries can also require intellectual property (IP). In order to avoid default, further studies are required on the efficacy of risk management or risk reduction. In addition, IMFAZ can be built according to trends. Now SRI Sukuk is on the bandwagon.

6.0 CONCLUSION

Sukuk ijarah mawsufah fi al-zimmah is a leasing-based, creativity variant of ijarah. This is also known as forward leasing includes building a complete or incomplete asset, facilities either by construction or manufacturing as the leasing aspect exists. Thanks to ijarah, which has a solid and well-grounded sharia perspective, it is graded as impressive Sukuk structure. Subsequently, it has an additional benefit in terms of funding and investment instruments for which it can be used not only in small scale but also in large ventures involving massive capital. While the application of ijarah mawsufah fi al-zimmah in Malaysia is relatively small, there is potential for growth particularly in the setting up of outsized government projects, large corporations. However, due to the fact that the government is still engaged in infrastructure and project building, the sovereign Sukuk is highly important in using this Sukuk, which will support the Sukuk holders at a later point. Nonetheless, this forward Sukuk has its own distinct problems that need to be tackled in order to harmonize and systematize the potential development of Sukuk ijarah mawsufah fi al-zimmah.

REFERENCES

- Abu Ghuddah, A.S. (n.d). Practical Application of al-Ijarah al-Mawsufah fi al-Zimmah (Forward Ijarah). Retrieved from <http://www.iefpedia.com/english/wp-content/uploads/2009/10/Practical-Application-of-al-Ijarah-al-Mawsufah-fi-al-Dhimmah-Forward-Ijarah.pdf>
- Al-Kasani, A.A. (1986). Bada'i' al-Sana'i' fi Tartib al-Shara'i'. Beirut: Dar al-Kutub al- 'Ilmiyyah.
- Al-Qurah Daghi, A.M. (2004). Sukuk al-Ijarah. Majallah Majma' al-Fiqh al-Islami. Session 15.
- Capital Intelligence. (2016). Definition of Default. Retrieved from <http://www.ciratings.com/page/rate-methodologies/definition-of-default>
- Creswell, J.W. (2007). Qualitative Inquiry and Research Design: Choosing among Five Approaches, Merrill, New York, NY.
- Denzin, N.K. and Lincoln, Y.S. (2008), Strategies of Qualitative Inquiry, 3rd ed., SAGE Publications, Thousand Oaks, CA.
- Hamdan, M. A. (2020). The Edge Financial Daily. <https://www.theedgemarkets.com/article/2020-corporate-bond-Sukuk-issuance-se-en-rm90brm100b>
- Hammad, N. (2010). Fi Fiqh al-Muamalat al-Maliyyah al-Masrafiyyah al-Mu'asirah. (2nd Ed.). Damascus: Dar al-Qalam.
- Hassan, H.H. (n.d). Sukuk al-Istithmar. Retrieved from <http://www.hussein-hamed.com/>
- IFC-MWL. (1982). Resolutions of Islamic Fiqh Council Makkah Mukarramah. Retrieved from <http://themwl.org/downloads/Resolutions-of-Islamic-Fiqh-Council-1.pdf>.
- IFSB. (2009). Capital Adequacy Requirements for Sukuk, Securitizations and Real Estate Investment. Kuala Lumpur: Islamic Financial Services Board.
- Kahf, M. (2011). Asasiyyat al-Tamwil al-Islami. Kuala Lumpur: International Shariah Research Academy for Islamic Finance.
- Merriam, S.B. (2009). Qualitative Research a Guide to Design and Implementation, Jossey-Bass, San Francisco, CA.
- [1] Mohamed Naim A., (2020). Interview. Islamic Business School, UUM. 13th August.
- RAM Rating Services Berhad. (2019). Malaysia's Sukuk issuance in 1Q 2019 shored up global performance. <https://www.ram.com.my/pressrelease/?prviewid=4961>
- Sairally, B.S, Habib, F., Hassan, H.K, Othaman, M.Z, Muhammad, M., Badri, M.B., Zada, N., M.Hasan, S. & Al-Badani, Y.A. (2017). Sukuk: Principles and Practices. Kuala Lumpur: International Shari'ah Research Academy for Islamic Finance (ISRA).
- Securities Commission Malaysia. (2011). Guideline on Registration of Credit Rating Agencies. Kuala Lumpur: Securities Commission Malaysia.
- Shahar, W. S, Shahar W.S.S & Jamlus, N. (2014). "Islamic Investment: Critics on Sukuk and Bonds". Proceeding of the 1st International Conference on Management and Muamalah 2014 (1st ICoMM). 13-14th November 2014. p: 139-150.
- [2] Yazid, Isa M., (2020). Interview. Islamic Business School, UUM. 13th August.
- Yin, R.K. (2014), Case Study Research Design and Methods, Sage Publication, Thousands Oak, CA.

Waqf EDUCATION FOR PRIVATE UNIVERSITIES IN MALAYSIA: DEVELOPMENT AND PROSPECTS

Lydiawaty Hassan Busry^a & Nurul Huda Abdul Majid^b

^a*Kolej Universiti Islam Pahang Sultan Ahmad Shah (KUIPSAS) Malaysia*

^b*Universiti Utara Malaysia, Kuala Lumpur, (UUMKL) Malaysia*

Abstract

Waqf plays a crucial role in the growth of a higher education institution and also creates excellent human capital. Nowadays, fees at higher education institutions, particularly private universities, are very high and mostly burden the students. Existing educational financial aid cannot afford the entire cost of the tuition fees. History has proven that the *waqf* can provide better economic, educational and social support to Muslims. Most of the educational institutions in West Asia have long used endowed property for the management, expenditure and construction of universities. Therefore, it is not surprising that the fees paid by students are relatively low and not burdensome, apart from providing continuous benefits to donator who endow their property. Driven by that fact, this article aims to restore awareness of *waqf* towards education in overcoming issues related to students, including sustainability in private higher education. This study provides a better understanding for institutions of higher learning, in particular private universities or colleges towards *waqf* in education. It is important as the starting point to empower *waqf* for the benefit of future generations. It does not only give advantages to the students but also to the growth of the institutions itself.

Keywords: *Waqf*, endowment, higher education

1.0 INTRODUCTION

Waqf in education is important realising the needs of society group that have limited access to education fund. Nowadays, there are 14 public universities and 6 private universities have established *waqf* in collaboration with their respective Majlis Agama Islam Negeri-negeri (MAINs). Universiti Sains Malaysia (USM), Universiti Kebangsaan Malaysia (UKM), Universiti Putra Malaysia (UPM) and University Sains Islam Malaysia (USIM) were pioneers among the public universities that had been implemented *waqf* fund since 2009 (JAWHAR, 2018). The sustainability of public as well as private universities is imperatives towards future nation's agenda as outlined by UNESCO in promoting Education for Sustainable Development (ESD) in connecting the global and local, leaving no one behind, promoting human rights and gender equality, and addressing economic, social and environmental sustainability while respecting cultural diversity (News Straits Times, 2019).

Addressing cost and budget constraints in line with the demand for quality higher education institutions today, universities are expected to diversify and generate their own income. Recognizing the importance of *waqf* in the development of institutions of higher learning, it is encouraged that all the public universities to create and expand their income through *waqf* (The Sundaily, 2016). The statement is highlighted by the Minister of Ministry of Higher Education Malaysia (MOHE); Datuk Seri Idris Jusoh which due to that reason, a guideline was developed by the MOHE called UniTP Purple Book 'Enhancing University Income Generation, Endowment and Waqf (2016) to enhance income generation from alternative and complementary sources. There are three objectives of the UniTP Purple Book which are (a) to generate income from varied sources on funding the universities (b) to ensure the financial stability of the universities through the endowment and (c) to implement the *waqf* model towards financial sustainability of the universities.

Considering the importance of *waqf* to public universities in addressing the cost and budget issues, it is imperative that private universities take a look at the government policy of diversifying their financial resources as private universities rely on their own financial resources and not fully tied to the government. This paper attempt to discuss education *waqf* and its practice in Malaysia context. Specifically, concepts related to *waqf* and endowment are the highlight and its advantages for the benefit of institutions stakeholders.

2.0 ENDOWMENT CONCEPT IN INSTITUTIONS OF HIGHER LEARNING

Endowment is the concept applied long ago even in the west involving institutions of higher learning. It basically helps to develop the institution in which the endowment received is to assist in the operating costs, governing and administering the developing human capital as well as raising the standard of education and, helps many people to improve their intellect. In addition, *waqf* has been practiced in the education sector widely in the Muslim world where the establishment of school, remunerating the teacher, providing scholarships to students are funded by *waqf* funds (Akhunov, 2015). The *waqf* fund in specific, the *waqf* education roles are varied in the development of educational institutions. By providing opportunities for the community to pursue further education in higher institution, it does not only give advantages to the students but also to the growth of the institution itself. History has proved, major institutions even in US were operated and financed through endowment that are not tied with the budget from the government. Yuhanis (2017) highlights the rebranding of *waqf* is believed to be consistent with the successful Islamic model of education in world famous earliest universities such as al-Qarawiyy University, al-Azhar University, the Cordova University, and al-Fateh University.

The *waqf* education has been seen in the implementation of *waqf* in higher institutions through endowment which can be referred from Universities of Oxford and Cambridge in the UK and also Harvard and Yale in the USA. Indeed, the idea of the endowment is very close to *waqf* and has already been widely practiced in the Muslim community, especially in the earlier days of Islamic civilization (Mahamood *et. al*, 2015). The system was proven successful in financing the scholars' activities and the development of their educational development. Therefore, by diversifying their revenue, the university should not rely on external sources to survive and without doubt, become a self-reliant university.

Concepts of *waqf* in education originated from the word *waqf* which literally means to halt, to pause or to hesitate. The legal meaning of *waqf* is the retention of its principal and the dedication of its products. In Islamic jurisprudence, *waqf* means contributions that have lastingness and continuousness for generations to benefit from it. This ensures that *waqf* is kept intact and used for the specific purpose only from the residual income generated from it (Ismail, 2013). The property of *waqf* is held from any sale, inheritance, hibah and it will maintain its physical resources ('*ain*). In this context, the property donated by a donor for charity towards communities benefit for the sake of Allah SWT. Once the property has been designated for *waqf* purpose, it is no longer a donor's property and the property cannot be taken back nor be owned by anyone.

Waqf is no stranger in Malaysia from the perspective of education development especially in specific institutions of higher learning. This philanthropy activity which can be used in education shows various *waqf* fund were established. Among others, the IUM Endowment, Cash *Waqf* Fund for Kolej Islam Melaka (KUIM) and Dana *Waqf* Ilmu, of UPM. Dana *Wakaf* Ilmu for example was set up in 2011 offering opportunities for campus communities and the general public to contribute to the *waqf* fund. *Waqf* contributions are made through the UPM *waqf* counter, *waqf* collection boxes placed at various offices in UPM, CIMBClicks, monthly salary deduction, and staff claims facility (e-claim). A total of RM7.1 million has been collected as of May 2016 (MOHE, 2017). *Waqf* is basically an exclusive religious endowment and the understanding of *waqf* roles become more popular in higher education in Malaysia, in particular when the private institutions take place in the education system.

3.0 EDUCATION WAQF PRACTISES: DEVELOPMENT AND PROSPECT

Waqf in education is one of the mechanism for socio economic development in parallel to the role of *zakah* for *fisabilillah* specifically to the students and education institutions. It is notable from the history where most of the funds of Al-Azhar University in Cairo and the College of Abu Hanifah in Baghdad were derived from *waqf* fund. Meanwhile, Cizakca (1998) highlights that Turkey has a fascinating history of *waqf* where the country has been enjoying the flourishing *waqf* culture since the medieval Selcuk and early-modern Ottoman Empire until the 19th century. It is proven with the designation of 1967 *Waqf* Law which shown effort to *waqf* practice were utilised besides education. Even until now, Turkey had a massive process of centralization *waqf*'s system. The concept of *waqf* also had been practiced by the Western through endowment long time ago. It is proven based on statistics on endowments shown in Table 1.1 below.

Table 1.1: Endowment funds by rank order of the 20 universities and colleges with the highest endowments: Fiscal Year (FY) 2015

INSTITUTION	RANK ORDER	MARKET VALUE OF ENDOWMENT (IN THOUSAND OF DOLLARS)	
		Beginning of FY	End of FY
United States, all institutions		\$533,105,732	\$547,217,872
Harvard University (MA)	1	36,429,256	37,615,545
Yale University (CT)	2	23,858,561	25,542,983
University of Texas System Office	3	25,445,315	22,548,856
Princeton University (NJ)	4	20,576,361	22,291,270
Stanford University (CA)	5	21,466,006	22,222,957

Source: U.S. Department of Education, National Centre for Education Statistics. (2018). *Digest of Education Statistics, 2016* (NCES 2017-094)

According to Berita Harian dated 28th March 2017, Harvard University's largest financial source comes from endowment. For the most recent fiscal year ended June 30, 2019, the return on the Harvard endowment amounted to 6.5% and the value was \$40.9 billion. The endowment contributed more than \$1.9 billion to the operating budget of the University, in support of financial assistance, academic grants, faculty support and more (HMC, 2019). Most of the funds were donated through various groups as alumni associations, individuals and organization. Besides that, they were diversifying their investment portfolios as shown in the Table 1.2. This method can be applied by private higher educational institutions in our country to obtain sources of funds for the development of the institution itself.

Table 1.2: Harvard Management Company's Investment Portfolio

ASSET CLASS	ALLOCATION	RETURN
Public Equity	26%	5.9%
Private Equity	20%	16%
Hedge Funds	33%	5.5%
Real Estate	8%	9.3%
Natural Resources	4%	-12.4%
Bonds/TIPS	6%	5.7%
Other Real Assets	2%	-8.3%
Cash & Other	2%	-
Endowment	100%*	6.5%

*Due to rounding, the approximate allocation adds up to more than 100

Source: Harvard Management Company Fiscal Year 2019 Report

3.1 Malaysian practise

The history of education in Malaysia begins with traditional religious-oriented institutions like Sekolah Agama Rakyat (SAR), Sekolah Agama Negeri (SAN), *madrrasah* and '*pondok*' (Asmak, 2009). In Malaysia, Muslims donate their property to build religious schools and homes for teachers. It can be said that traditional *waqf* on education is in the form of land, houses, mosques, buildings, and books (Hisham Sabri, 2007). The development of educational *waqf* nowadays is no longer focused on the provision of '*pondok*', *madrrasah*, book donations in the name of traditional educational systems and schools. Educational *waqf* involves public and private universities with specific funds to be established. Among others, the International Islamic University of Malaysia (IIUM) established the IIUM Endowment Fund in 1999, the Universiti Kebangsaan Malaysia (UKM) with Dana *Waqaf* and UKM Endowment in 2010, Universiti Putra Malaysia (UPM) with Dana *Wakaf Ilmu* UPM in 2012 followed by the Universiti Sains Islam Malaysia (USIM) in 2013 under the Dana *Wakaf Al-Abrar*. The Al-Bukhary International University (AiU) in Kedah is an example of a private institution of higher learning in Malaysia funded entirely by a *waqf* fund. Another example is the institution of higher learning, Universiti Islam Malaysia (UIM) and University College Bestari (UCB). The main goal of the establishment of UCB is to improve the education of orphans, the poor and students in rural areas. The UCB campus was set up on a 320-acre land that was approved by the Terengganu State Government and Majlis Agama dan Adat Istiadat Melayu (MAIDAM) as *waqf* land. MAIDAM functioned as the trustee for all kind of *waqf* in Terengganu. The presence of UCB can give orphans and the poor more opportunities to pursue higher education and reduce the problem of dropouts among them besides giving them employment opportunities and increase the socio-economic. The success of UCB in using *waqf* as a means of raising funds can be the best model for other private higher institutions especially in the East Coast region to follow, at the same time it will reduce the dependence on government funds (Hussin *et. al*, 2016).

3.2 Sustainability of Waqf Education: The Malaysian Private Universities

Waqf for education in Private Universities in Malaysia becoming an important instrument for sustainability of universities which are independent from government. Examples of the practices of *waqf* to the benefit of the students and community are discussed.

Al-Bukhary International University (AiU)

Al-Bukhary International University (AiU) was founded by Syed Mokhtar al-Bukhary in Alor Setar, Kedah in 1996 known as *waqf* university. The students were sponsored through the Syed Mokhtar al-Bukhary Foundation scholarship which includes accommodation, food and drinks as well as free based learning costs. The existence of this institution has changed the lives of the less fortunate which able to finance the children who are in need to higher education with the sponsorship of *waqf* funds by Al-Bukhary Foundation.

Universiti Islam Malaysia (UIM)

UIM's construction was based on the *waqf* principle that started with the *waqf* of the former Selangor Sultan who donated Istana Jameah (Jameah Palace) to Kampung Jawa in 1955 as a Kolej Islam Malaya (KIM) campus representing the progress of education in Malaya. In line with its existence, UIM is obliged to support any sort of *waqf* contribution to the mission until it becomes a university that continues to grow in Islamic endowments without relying on government or private contributions, thereby ensuring freedom of knowledge and intellectual growth. The UIM *waqf* matters will be supervised and consulted by a group called the Shariah Council, made up of experts in Shariah Law. In line with the government's desire to increase the value of human resources, *waqf* education itself will be able to offer significant benefits to the Malaysian community as well (Mustaffa *et. al.*, 2014).

Universiti College Bestari

University College Bestari (UCB) (formerly known as Kolej Teknologi Bestari (KTB)). The main goal of the establishment of UCB is to improve the education of orphans, the poor and students in rural areas. The UCB campus was set up on a 320-acre land that was approved by the Terengganu State Government and Majlis Agama dan Adat Istiadat Melayu (MAIDAM) as *waqf* land. MAIDAM functioned as the trustee for all kind of *waqf* in Terengganu.

Kolej Universiti Insaniah (KUIN)

Bank Islam Malaysia Berhad (BIMB) and University College INSANIAH (KUIN) has signed a Memorandum of Understanding (MoU) in 2014 whereby both parties will collaborate to realise the "INSANIAH Waqf Fund" project. The purpose of the project is to develop a mosque in KUIN in Kuala Ketil, Kedah. The trustee for the project is Kedah Islamic Council (MAIK).

Universiti Tenaga Nasional (UNITEN)

UNITEN Endowment Fund Ecosystem comprising Yayasan Canselor UNITEN (YCU), Tabung Amanah Zakat UNITEN (TAZU), Alumni Endowment Fund (ALEF) and Dana Wakaf Ilmu UNITEN (DWIU) which aims to ensure long term financial sustainability of this institution. Realising the importance of endowment in attracting and retaining best and brightest students as well as expanding their academic programmes and research efforts, UNITEN determined to raise cumulative endowment funds worth of RM104 million by 2025. YCU managed to raise RM2, 677, 686, 000 for the year 2018. The pool of fund is collected mainly from philanthropies and corporate companies, via YCU annual events, monthly salary deduction of TNB's staffs and also UNITEN Alumni.

Multimedia University (MMU)

The goal of the Yayasan Universiti Multimedia (YUM) or the Multimedia University (MMU) Foundation, registered on 12 February 2009 under the Trustee Act 1952, is to provide students with the best available technology with the best education available. YUM is founded as a non-profit organisation and enjoys the status of a tax exemption in accordance with Section 44(6) of the Income Tax Act 1967. YUM is expected to produce more revenue with the patronage and commitment of influential individuals and corporate organisations. With the funds generated, other than providing financial assistance to outstanding and well-deserved underprivileged students, YUM strategically channels funding for education through improvements for teaching and learning facilities and research sponsorships. YUM invites pledges of any scale of all individuals and corporate organisations that share a similar goal to support the nation's search for outstanding human capital to partner with them in this noble cause.

3.3 Prospects and Challenges Waqf Education

As mentioned, various educational financing purposes including the construction of facilities for students and scholarships for poor students can be utilised through *waqf* education in institutions of higher learning, specifically other than the public university in Malaysia. Cash *waqf* contributed for education is one of the mechanisms. Instead of paying fees, societies can do charitable work, the benefits which its last until the end of time by contributing to

the cash *waqf* scheme at school. The community will be more interested in contributing more ringgit than just paying the fees in order to get multiplied rewards. In this respect, this is based on a famed hadith as mentioned by Muslim; the Prophet (PBUH) said: “*When a human being dies, his work for God comes to an end except for three: a lasting charity, knowledge that benefits others and a good child who calls on God for his favor*”

On the other hand, *waqf* in corporate sectors via efforts from various parties becoming popular nowadays. In developing the *waqf* for education, it is believed that it can meet three core needs, namely the development of the higher education and its facilities, covering the daily operating costs of the university and activities of academic excellence, personality and leadership of students and lecturers. Funds can be generated using crowd funding, alumni participation, employees' salary deduction etc. YCU managed to raise RM2, 677, 686, 000 for the year 2018. The pool of fund was collected mainly from philanthropies and corporate companies, via YCU annual events, monthly salary deduction of TNB's staffs and also UNITEN Alumni. Through this, not only Muslims can get the benefits but also non-Muslims can enjoy the convenience of the proceeds collected through this *waqf* fund. At the same time attracting the interest of non-Muslims with the goodness practiced by Muslims.

Waqf is included in the category of Donations or Gifts of money in accordance with Section 44. Any contribution whether in the form of corporate responsibility, donation or *waqf* is allowed as tax relief under the provision of subsection 44 (6) Income Tax Act as donations and gifts and can be claimed for tax relief. However, in contrast to zakat which is categorized as a 'religious obligation' and obtains a 100% rebate, tax relief for the category of donations and gifts is categorized as not a 'religious obligation' and only gets a limited relief of only 7% of aggregate income.

The *waqf* administration in Malaysia is now towards the digitization and use of financial technology (Fin Tech) to prevent any leakage, thus generating more comprehensive development. Minister in the Prime Minister's Department, Datuk Seri Dr Mujahid Yusof Rawa, said the use of digital platforms such as blockchain and artificial intelligence (AI) will help ensure the implementation of governance more efficient, transparent and Shariah-compliant (Berita Harian, 2019). In realizing that goal, the Minister said, the government is currently in the process of creating the Endowment Act and now it is at the stage of discussion involving all relevant parties such as information technology (IT) experts. In the meantime, Malaysia will be the first country in the world to use the digital Islamic administration platform if the *Waqf* Act can be implemented

4.0 CONCLUSION

In conclusions, educational *waqfs* should be applied based on the concept of not relying on any of the government's financial resources which is dominated by the political system. The *waqf* sources at Al-Azhar University and elsewhere in the world proved that the Islamic education system is capable of spreading its benefits to all Muslims who want to gain knowledge. In this era of globalization, it is a challenge for educational institutions to provide the best, most efficient education at every level of education for all classes of society. This study may be significant in exploring awareness towards educational *waqf*. It is also hoped that the contents of this study will attract private universities to initiate and practice toward establishing this as part of *waqf* instruments since a lot of implication of educational *waqf* towards Muslim society especially students and staffs can be gained.

REFERENCES

- Adam, S a. (2013). Cash Endowment as Source of Fund in Islamic Microfinancing: 4th International Conference on Business and Economics Research (4th ICBER 2013)., (pp. 1362-1378).
- Akhunov, A. M. (2015). Issue of Waqf in the Context of Establishment of Muslim Institutions in the Post-Soviet Tatarstan. *Journal of Sustainable Development*, 8(5), 157–163.
- Al Bekari, H. J., & Supian, K. (2019). Sustainability of Endowment Fund in the Sultanate of Oman: A Conceptual Study. *Journal of Islamic, Social, Economics and Development (JISED)*, 4(22), 35 - 43.
- Asmak. (2009). Peranan Wakaf dalam Pembangunan Ekonomi Umat Islam dan Aplikasinya di Malaysia. *Syariah Journal*, 17(1), 113-152.
- Bank Islam (2014) Media Release. Retrieved from <http://www.bankislam.com.my/home/assets/uploads/Press-ReleaseENG-DanaWaqafNSANIAH.pdf> Kuala Lumpur.
- Berita Harian (2017, March 28th). Teraju Universiti Berasaskan Wakaf. Retrieved from <https://www.bharian.com.my/taxonomy/term/61/2017/03/264938/teraju-universiti-berasaskan-wakaf>
- Berita Harian (2019, July 12th). Pentadbiran wakaf ke arah digital, FinTech. Retrieved from <https://www.bharian.com.my/bisnes/lain-lain/2019/07/584207/pentadbiran-wakaf-ke-arrah-digital-fintech>
- Bernama. (2009). Dr. Al-Qaradawi gives RM40,000 to IIUM Endowment Fund. Education News Update.
- Bernama. (2016, Oct 20). Public universities to increase waqf funds: Idris Jusoh. The Sunday, Retrieved from <https://www.thesundaily.my/archive/2010097-ITARCH402585>
- Cizacka, M. (1998). "Awqaf In History And Its Implications For Modern Islamic Economies". *Islamic Economic Studies*, Vol. 6, No. 1, (Jeddah: IRTI & IDB).
- Hisham Sabri (2007). Wakaf : Pengurusan dan Sumbangannya Terhadap Pendidikan Islam di Malaysia, *Journal of Muamalat and Islamic Finance Research*. Vol. 4 No. 1.
- Ibrahim, H., Amir, A., & Masron, T. A. (2013). Cash Waqf: An Innovative Instrument For economic Development. *International Review of Social Sciences and Humanities* Vol. 6, No. 1, pp. 1-7.98
- Ismail, Azman. (2013). Islamic Inheritance Planning 101. IBFIM. Kuala Lumpur.
- JAWHAR. (2006). Manual Pengurusan Tanah Wakaf. JAWHAR. Kuala Lumpur.
- JAWHAR. (2018). Panduan Pengurusan Wakaf: Institusi Pendidikan. JAWHAR. Kuala Lumpur.
- Kamus Dewan. Edisi keempat, Kuala Lumpur: Dewan Bahasa dan Pustaka, 2007.
- M. R. A. Aziz, F. J., & Yusof, M. A. (2013). Cash Waqf Models for Financing In Education. Paper Proceeding of the 5th Islamic Economics System Conference (iECOMS): "Sustainable Development Through the Islamic Economics System". Organized by Faculty Economics and Muamalat, Universiti Sains Islam Malaysia.
- Masyita, Dian & Tasrif, Muhammad & Telaga, Abdi. (2010). A Dynamic Model for Cash Waqf Management as One of The Alternative Instruments for The Poverty Alleviation in Indonesia.
- Ministry of Higher Education Malaysia. (2017). Enhancing University Income Generation, Endowment & Waqf. Retrieved from <https://www.mohe.gov.my>
- Mohamad Khairul Izwan, Rifin & Mujani, Wan & Taib, Mohd & Suhaili, Nur & Ismail, Nur. (2016). Waqf and Endowment of Private Universities in Malaysia.
- Mohd Ashrof Zaki Yaakob, Mohammad Mahyuddin Khalid, Azri Bahri, Baharuddin Sayin & Mohd Afandi Mat Rani. (2017). Pembangunan Holistik dalam Wakaf Pendidikan Tinggi di Malaysia. Penerbit UiTM.
- Mohd Syakir Mohd Taib, Wan Kamal Mujani, Ermy Azziaty Rozali & Kartini Aboo Talib @ Khalid. (2017). Perkembangan Wakaf Pendidikan Tinggi di Malaysia. *International Journal of West Asian Studies*. Vol.9, No.1 (pp 82-92).
- Mujani, Wan & Taib, Mohd & Mohamad Khairul Izwan, Rifin. (2016). Waqf Higher Education in Malaysia. 10.2991/iceemt-16.2016.100.
- Multimedia University. (n.d). Yayasan Universiti Multimedia (YUM). Retrieved from <https://www.mmu.edu.my/vayasan-universiti-multimedia-yum/>
- Mustaffa, Najibah & Muda, Mohd. (2014). Pengurusan Wakaf Pendidikan di Institusi Pengajian Tinggi Malaysia: Satu Sorotan Literatur. *UMRAN - International Journal of Islamic and Civilizational Studies*
- News Straits Times (2019, June 4th). Revisiting Education For Sustainable Development. Retrieved from <https://www.nst.com.my/opinion/columnists/2019/06/493960/revisiting-education-sustainable-development>
- Ridzwan, B. (2018). Cash Waqf for education: Prospects and challenges. *Journal of Emerging Economies & Islamic Research* 6(2) 2018, 1 – 4
- Rohayati Hussin, Rusnadewi Abdul Rashid dan Noor Inayah Yaakub. (2016). An exploratory study on waqf implementation in Malaysian public and private universities: with special reference to Turkish universities. *International Journal of Business, Economics, and Law*, 9 (4), 2289-1552.
- Siti Mashitoh Mahamood & Asmak Ab Rahman, (2015), "Financing universities through waqf pious endowment: is it possible?, *Hum anomics*, Vol. 31 Iss 4 pp. 430 – 453.
- Siti Mashitoh Mahamood. (2001). The Legal Principles of Waqf An Analysis, *Syariah Journal*, 9:2 (2001) 1-12.
- Universiti Tenaga Nasional (2018). Annual Report 2018. Retrieved from <https://www.uniten.edu.my/media/2855/uniten-annual-report-2018-compressed.pdf>
- Yayasan Wakaf Malaysia. (2013). YWM Lancar Sistem Wakaf Tunai Malaysia (Buletin).

SHARIA COMPLIANT OF CROWDFUNDING THROUGH THE FINANCING PLATFORMS IN SMALL MEDIUM ENTERPRISES (SME)

Anita Ismail^{*a}, Farah laili Muda @ Ismail^b, Mashitah Sulaiman^c, Norhaziah Nawai^d

a,b,c,d Universiti Sains Islam Malaysia, Malaysia

Abstract

This conceptual research seeks to explore the sharia compliant of crowdfunding, which is relatively a new trend in alternative financing, particularly the financing innovation platforms with respect to the small medium enterprises (SME) for sustainable development. This research aims are to describe, analyse and to increase the knowledge of crowdfunding from the sharia governance framework, new regulation, novel security technology and services in financing platform, technology innovation of social media (i.e., Facebook, Instagram, twitter, and WhatsApp) during the new emergent crowdfunding phenomenon. This work follows a theoretical analysis of literature to describe crowdfunding and its financing platforms with the main focus on equity and donation based crowdfunding investment. The research methodology follows a path of inductive-deductive analysis, by the assessment of the compliance with the sharia. the evaluation process and compliance are based on two categories: the first category consists of the quality criteria and the second those quantities. The qualitative criteria are mainly related to the business activities of the company and its eligibility according to the sharia. regarding the quantitative criteria, are a series of reports and financial levels that need to be examined, and their results should not exceed the specified threshold. This study will contribute to the development model for sharia compliant in SME given the constraint in terms the choice of capital in financing their operating and investment activities. crowdfunding grows fast in Malaysia due to countless support from government and industry players. the ability to efficiently resolve the financing difficulties of SMEs provide satisfactory returns to the investors are not the only benefits crowdfunding can offer. sharia compliant crowdfunding for instance, able to bring positive social impact in any community-based project.

Keywords: Crowdfunding, Sharia Compliant, Platform, Small Medium Enterprises

1.0 INTRODUCTION

Crowdfunding is already part and parcel to many organizations and individuals wish to make the world a better place and help people around the globe to improve their lives. Its obvious benefit is raising money. Crowdfunding is credited with overcoming financing barriers to small grassroots projects that don't have access to banks and large donors. Crowdfunding not only provides money to organizations; it also boosts their manpower as the crowd that funds them also puts their institutional structures on a broader footing. The supporters unwittingly become an additional marketing team by promoting the project they funded to their friends and networks. Through the increased communication and visibility during a crowdfunding campaign, international development work, still mostly funded with tax-payer money through government agencies, can also gain more visibility among the population and thereby increase its legitimacy.

Crowdfunding is a new issue in Malaysia, where the concept is less about the donation or charity. Crowdfunding industry in Malaysia is still considered in its infancy with the level of awareness and acceptance of the crowdfunding still low. However, this platform can be among the best financing mechanism for Islamic finance, it is also the appropriate financing mechanism. Some of the issues raised about Sharia compliant should not be an obstacle, but a responsibility of Shariah advisors to provide solutions to the issues rose. The existence of crowdfunding industry in Malaysia is an improvement in the capital market that every Malaysian should be proud of (Biancone, P. Pietro, & Secinaro, S., 2016). Therefore, it is very important to know about the efforts to address the challenges associated with crowdfunding and the important factors that should be considered by the owners and operators of the project prior to engaging with the public to finance their projects or business ideas.

This research seeks to examine the concept of crowdfunding, which is relatively a new trend in alternative financing. This crowdfunding model has received serious attention by Malaysia government by issuing regulations to fund investment through crowdfunding platforms. Islamic crowdfunding or sharia crowdfunding is a crowdfunding

platform model that operates according to Islamic principles in business. This model is fairly new in the midst of the development of the financial technology business, due to special market niches with the criteria for halal business.

The justification behind those fundraising provisions is to reduce risk of loss, especially for retail investors as in general they are not experienced. The risk of loss, problem with liquidity, fraud and difficulty in taking legal action on issuer are among the challenges faced by investors. Besides the manifold potentials, crowdfunding as a source of financing may also pose some challenges. Uncertainty and risk for backers and cost of capital for the project initiator are the most important ones. However, crowdfunding does not only include uncertainty for backers but also for project initiators. For instance, many project initiators who use crowdfunding as pre-sales mechanisms do not possess scalable production facilities. As a consequence, many products and other rewards are delivered with delay, potentially damaging the reputation of the project initiator. This may also decrease profitability of the project due to unforeseen extra costs.

From the aspects of the problems and challenges faced in the development of Islamic financial technology industry, the core and basic problems are:

- a. Lack of policy instruments guarding the fintech work process,
- b. Availability of human resources for fintech,
- c. High security risks from malware attacks, and not reaching lower-class consumers
- d. Legal certainty of online-based loans, and
- e. The need for improvement in aspects of governance, accounting and sharia auditing
- f. Lack understanding of sharia

The uniqueness of Sharia crowdfunding also presents a new challenge for the platform providers to have a sharia supervisory board. Sharia crowdfunding in turn would not be considered as formality in such, but to develop financial technology in sharia context. This platform will expand the market share of the Islamic finance business, considering that sharia business has now penetrated into the world of crowdfunding business. In addition, the development of the digital world has had a lot of impact on people's lives, giving rise to a new order (Irfan, 2016), as well as that of Muslim life. As a manifestation of good technological use, speed and advanced technology can be used to support the success of the Islamic finance business in the digital era.

The research questions are as follows:

- a. What is the Sharia Governance Framework of crowdfunding?
- b. What is the new regulation for modelling Sharia compliant of crowdfunding?
- c. What is the novel technology in the financing platform?
- d. What is the technology innovation of social media (Facebook, Instagram, twitter, WhatsApp, etc.) effect the crowdfunding during a pandemic?
- e. What is the financing platform of crowdfunding of SME for sustainable development in Malaysia?

Along with the increasing digital technology, fraud is also haunted to disturb it. Protection for digital-based financial business is badly needed for the crowdfunding users. Until 2016, the government has not provided legal certainty regarding crowdfunding official business and regulations. Crowdfunding consumers only conduct transactions based on trust without legal protection. This weakness should be a salient issue for the government to pay special attention to digital-based businesses such as crowdfunding. This security side come to be a failure of crowdfunding business, due to the consumers are not protected. In the near future, the government needs to take steps to provide legal certainty in the digital-based businesses.

2.0 CROWDFUNDING FOR SMALL AND MEDIUM ENTERPRISES (SMES)

The crowdfunding is a collaborative process of a group of people who use their money in common to support the efforts of people and organizations using Internet sites. It is a bottom-up micro finance practice that mobilizes people and resources. The term crowdfunding derives its origin from crowd-sourcing or collective development of a product. It can refer to initiatives of any kind, from financing an entrepreneurial project to supporting art and cultural heritage, to innovative entrepreneurship and scientific research.

Collective financing is often used to promote innovation and social change, breaking down the traditional barriers of financial investment. Therefore, it differs from the other models because of the particular "reward" expected by those who contribute to the project. According to the Framework for European Crowdfunding, "the rise of crowdfunding in the last ten years derives from the proliferation and the emergence of web applications and mobile services, conditions that allow entrepreneurs, businesses and creatives of all kinds to be able to dialogue with the crowd to get ideas, collect money and solicit input on the product or service they intend to offer.

Crowdfunding is an important source of funding each year for about half a million European projects that otherwise would never receive the funds to see the light. In 2013, funds amounting to about one billion euro were collected in Europe. Exponential increases are estimated in the near future, millions of billions by 2020, thanks to crowdfunding, which finds all the elements to be able to unleash its potential in web 2.0. Concepts such as Fintech, bitcoin, crowdfunding enter the language of the banking business, including for Islamic finance. Fintech is the supply of financial services and products through the most advanced information technologies (ICT), is one of the most interesting phenomena of recent years. Exploded between 2014 and 2015, it has established itself in the banking sector, giving rise to new actors. Technological innovation has allowed reducing operating costs, favouring a policy of cuts. The success of Fintech and crowdfunding, which open new financial channels and give the customer much-simplified management of their activities, with the consequent cancellation of unnecessary management costs. Islamic finance is also affected by this revolution.

Crowdfunding has been proposed as a new financing mechanism. The original concept of crowdfunding is a showcase of ideas to the community. It is presenting an idea to the potential, large and anonymous public in order to have funding from them. In this regard, crowdfunding is also known with other names. According to Agerfalk & Fitzgerald (2008), Pisano & Verganti (2008), Poetz & Schreier (2012) and Grivenics et al. (2014), the practice is known as —crowdsourcing. Sometime, the individual contributes based on pure charity without expecting anything in return. "Crowdfunding can be defined as a collective effort of many individuals where their resources to support efforts initiated by other people or organizations. This is usually done through or with the help of Internet. Individual projects and businesses that are financed by small donations from a large number of individuals, allow innovators, entrepreneurs and business owners to use their social networks to raise capital (Calveri & Esposito, 2013).

Small and medium enterprises (SME) seeking financial support from traditional funding opportunities —bank loans and credits— might now face more challenges upon their request than several years ago. Referable to the financial market crisis and the ensuing regulations, these requests seem to be significantly more difficult. In this regard, crowdfunding is seen as a valuable alternative to the traditional funding opportunities in order to provide SME with the financial resources required (Rossi, 2014).

Lack of access to finance is the obstacle faced by the new SMEs in many countries including Malaysia. According to Beck and Demirci-Kunt (2006) SME firm still experiences various difficulties to boost developmental growth, particularly in financing. The contention is that SMEs demonstrate inherent riskiness and weaknesses such as a lack of robust business plans and insufficient capital that make it under served by commercial banks. Crowdfunding is an alternative source of financing that can close the financing gap for SMEs (Ahlstrom et al. 2018; Dunkley 2016; Gros, 2016). Crowdfunding is an innovative and relatively new concept that connects entrepreneurs with the investors through the Internet. This method allows the entrepreneurs to collect funds through the Internet by "open invitation" to finance their projects or ventures and thus raise the necessary funds by relatively small contributions of a relatively large number of investors. Through multiple small-scale investors, crowdfunding provides financing for commercial ventures (Pierrakis & Collins, 2013). Drake (2014) described it as "the practice of raising funds from two or more people over the internet towards a common Service, Project, Product, Investment, Cause, and Experience. The objective of crowdfunding is to collect money for investments using social networks on the Internet. Social capital is identified as a key factor on how entrepreneurs succeed in their crowdfunding campaigns (Vismara 2016; Agrawal et al. 2015) and achieve crowdfunding success through the start-up life cycle stages (Paschen 2017; Hornuf & Schmitt 2016). Crowdfunding enlarging finance for SME firm and entrepreneurs by offering financial backing when traditional forms of finance are missing; eliminates geographical barriers to raising finance; serves as path to identify good investment projects, which is a unique way to validate original ideas in front of a specifically targeted audience; and attracts investment by appealing to both financial and non-financial motives of the investors (Pierrakis & Collins, 2013). A study done by Eldridge, D et. al (2019) show that crowdfunding does have an impact on the growth opportunity of small firms, with a strong positive correlation. The study also shows a positive impact of crowdfunding on small firms' performance. Meanwhile Zainudin Awang et.al (2017) found that crowdfunding can influence self-belief of entrepreneurs and help to improve entrepreneurial performance. Paschen (2017) and Stanko and Henard (2016) concluded that crowdfunding affords a value proposition to SMEs, through enhancing a valuable organization base and also through non-monetary benefits such as learning from external feedback and leading to innovation.

3.0 ISLAMIC FINANCE AND CROWDFUNDING

The Islamic religion emphasizes the principle of Halal (permitted activity) emanating from the Shariah, which governs all activities in the life of Muslims. The Islamic finance, ideally, is an alternative way of financing based on ethical and socially responsible standards, which ensures fair distribution of benefits and obligations between all the parties in any financial transaction (Saaed, 1996; Biancone and Radwan, 2018; 2019). The crowdfunding carries these characteristics and provides the ground for new developments in the field, as it can use Islamic finance as an ethical

and socially responsible tool to promote financing and development. Islamic finance and crowdfunding both conceptualize costumers as investors and can potentially provide investment opportunities with higher returns investors take an equity stake in the project and gain returns based on the principle, which ensures a fair distribution between shareholders and entrepreneurs (Biancone and Secinaro, 2016).

The Islamic Financial Services Board has dedicated an entire section to the rise of the Fintech, its applications and the state of the legislation in force in its 2017 Stability Report to remove entry barriers and provide more financial services to the millions of Muslims. The concept and the structure of crowdfunding conform perfectly to Sharia and has the same participatory methods that are the cornerstone of Islamic finance, investors buy a share in the company by participating in gains and losses.

The sharia-compliant crowdfunding invests in halal socially responsible projects/products, shares the risks of the investment, and is characterized by the absence of an interest rate. The originality of product-based crowdfunding lies in the fact that in return, the investor does not receive interest, but the product itself, which promotes the creation of new products and furthers innovation. Investors that pay for a product they wish to have, can track the production process and see how their money is spent through weekly updates on the progress of the projects. Transparency is a very important part of the project, and a direct link between the customer and the workshop owner is established from the beginning. Islamic finance to comply with the Quran requires socially responsible investment, with a real impact on the community, Sharia prohibits interest on loans and speculation (Biancone and Radwan, 2019). Whereas Islamic finance at the origin is value-oriented and aims at sharing risks and profits: hence the inevitable similarity to crowdfunding and its participatory methods.

There are four types of sharia compliance platforms (Marzban and M. Asutay, 2017).

a. Donation-based crowdfunding (saqadah and cash waqf)

Charities great start collecting donations online long before web-based crowdfunding appears. But in 2010, a donation-based crowdfunding site recently allowed a very small organizations and individuals to ask for donations from the public. In addition, donations were given property of one person (the donor) to another person or persons in need without expecting anything in return. In crowdfunding based on donations, the sponsors do not expect anything in return for the funds that have been provided. For example, global giving was founded in 2002 as a platform crowdfunding collect donations from people all over the world. Contributions received were used for charitable and social projects. GoFundMe is another example of crowdfunding platform based on donations.

b. Reward-based crowdfunding

Donors contribute small amounts of money in exchange for a reward after the completion of the project. The reward is a product generated by the project itself. In contrast to the donation-based crowdfunding sponsors to reward-based crowdfunding expect something in return for funds / contributions to the platform. Rewards in reward - based crowdfunding is in the form of recognition, like the name of the donor on a DVD movie or music cd. Examples based crowdfunding reward is Indiegogo and Kickstarter. More rewards-based crowdfunding platforms were launched, the most prominent of which were Indiegogo in 2008 and Kickstarter in 2009. In addition to the arts (including fine art, comics, dance, design, fashion, film and video, music, photography, creative writing, theater), these sites host funding campaigns for social causes (animals, community, education, environment, health, politics, religion) and entrepreneurs and small businesses (food, sports, gaming, publishing, technology).

c. Equity-based crowdfunding (musharakah)

At this stage, investors provide sums of money, become shareholders, share profits and losses. This kind of crowdfunding refer to form of cooperate fundraising for start-up or other similar companies as issues obtaining capital through equity investment which is small in nature. The equity-based crowdfunding is relatively from large numbers of investors with is made possible with online portals as the mechanism to publicize and facilitate such offers to crowd investors. Acquiring a percentage of ownership in a start-up or existing company founder has the opportunity to own a percentage of the company, almost similar to buying shares in investors who want to look beyond the traditional stock market when investing in a private company (Freedman & Nutting, 2014).

d. Debt-based crowdfunding (qard al-hasan)

The lenders grant a loan and expect the repayment of capital and the distribution of profit, the platform must rely on Islamic financial contracts and processes without interests such as the use of Murabaha & Ijarah. This kind of

crowdfunding is in similarity with the traditional concept of load in return from interest payment and repayment of the capital. The load will be in small amount where large number of individuals would be able to lead each of the small portions to form the total amount of load. Besides, providing a loan for parties, professionals or establishments who are unable to obtain a traditional loan or find a proper alternative. It Works when funder provides a loan and earns interest when the loan is repaid. Typically Appeals to investors who want to earn a profit by providing a loan with interest (Freedman & Nutting, 2014).

The screening to see if a company is Sharia compliant was based on qualitative and quantitative criteria. The qualitative criteria relate to the type of industry in which companies cannot operate: this sector includes all activities not permitted Haram, namely: alcohol and pork products, pornography, tobacco, gambling, interest-bearing financial assets, weapons and defense, biology and animal genetics (cloning). In quantitative screening, however, the financial reports of companies are tested for amounts not exceeding certain thresholds and thresholds are different in the percentages and formulas between different global indices.

4.0 CROWDFUNDING TECHNOLOGY

The development of Web 2.0 technologies within the past decade has enabled the evolution of new and innovative business models, in which the digital user plays an increasingly important role by changing the way goods are being used and consumed (Brenner et al., 2014). This digital user is no longer located at the end of the value chain, is an integral part of it, a co-decision-maker. This change requires whole industries to think and act differently leading to a fundamental transformation from offline business models to digital ones. In this context, crowdsourcing is a striking example. It describes the outsourcing of various tasks to an undefined group of people using information technologies (Blohm, Leimeister, & Krcmar, 2013). It helps companies to develop new ideas and innovations by including customers' needs and requests in the innovation process (Chesbrough, 2006). Crowdsourcing approaches often aim to benefit from the wisdom of the crowd (Surowiecki, 2004) and from collective intelligence (Leimeister, 2012).

The Internet has created a new dimension in conducting business. The technological advancements not only offer innovation in the creation of devices, but also implementation of new methods in doing business (Hanif, Halim, & Ismail, 2019; Sheela and Rahmah, 2017). Crowdfunding for instance, is a novel method for funding various new ventures. One of the main crowdsourcing forms besides crowdvoting and crowdcreation is crowdfunding (Howe, 2006; Leimeister, 2012). It can be defined as an open call mostly through the Internet for the provision of financial resources by a group of individuals instead of professional parties either in form of donations, in exchange for a future product or in exchange for some form of reward (Belleflamme, Lambert, & Schwenbacher, 2014; Schwenbacher & Larralde, 2012). Using a proverb, crowdfunding can be described as "many a little makes a mickle", meaning that a large amount of money can be raised by accumulating small contributions from a large group of backers. Therefore, using Internet platforms as intermediaries between individuals, start-ups or companies on the one hand, and potential backers on the other, the process of fundraising is sourced out to the crowd (Moritz & Block, 2014).

The crowdfunding market is still growing. The modern, digitized form of crowdfunding has its roots in the beginning of this century. Many of today's largest crowdfunding platforms are from the US and were launched from 2005 onward. In 2010, the crowdfunding wave swapped over to Europe. From this moment on, crowdfunding started to particularly gain momentum in the UK, Germany and the Netherlands, the most mature European crowdfunding markets. The overall market numbers indicate an impressive development of crowdfunding. According to the Crowdfunding Industry Report 2013, over 800 crowdfunding platforms are currently active or in the process of being built (Massolution, 2012).

5.0 CROWDFUNDING PLATFORM

Intermediaries are usually crowdfunding platforms specialized crowdfunding websites. Powers (2012) states, that these websites display business models and allow investors to make online contributions. The main purpose of such websites is connecting people (the crowd) to entrepreneurs and organization. The crowdfunding platforms could be divided into two types, according to the way they behave with collected money. The first type of crowdfunding platforms holds funds in an escrow account – if the needed amount is not reached, the contributions are returned to investors. The other type of crowdfunding platforms of technology innovation of social media (i.e., Facebook, Instagram, twitter, and WhatsApp) allows entrepreneurs to keep all the funds raised.

Assessing the intermediary crowdfunding platform, several distinctive characteristics can be found. They refer to the funding mechanism, the fundamental specialisation of the crowdfunding platform and the type of support/return (Haas et al., 2014). Funding mechanism in contrast to traditional financial intermediaries, crowdfunding platforms do not borrow, pool, and lend money on their own account. They focus on the matching of project initiators and backers

by providing information about the projects and functionalities, e.g. for reducing the risks of the investment. Therefore, crowdfunding intermediaries provide particular funding mechanisms, such as pledge levels, minimum pledge amounts and the all-or-nothing-/keep-it-all-principle (Gerber et al., 2012; Mitra & Gilbert, 2014; Mollick, 2014). Following the all-or-nothing-principle, project initiators are only paid out the collected amount in case they reach their pre-defined funding goal. This assumes that backers are only able to accomplish their project and to deliver the promised returns if they have the complete resources required for doing so. However, some crowdfunding platforms are based on a keep-it-all-principle in which project initiators receive any collected sum (Gerber et al., 2012). This funding principle is particularly used for charitable projects or projects which use crowdfunding as a subordinate source of funding (Blohm, Leimeister, & Kreimer, 2013).

The internet economy is characterised by hyper specialisation (Malone, Laubacher, & Johns, 2011). Serving the highly heterogeneous needs and requirements of project initiators and backers, crowdfunding platforms focus on specific niches and serve a particular segment of the crowdfunding market. Thus, crowdfunding platform specialisation may reach from innovative and creative projects or products (Agrawal, Catalini, & Goldfarb, 2010), start-ups and new businesses (Ahlers, Cumming, Günther, & Schweizer, 2012; Schwienbacher & Larralde, 2012) to sustainability and charity projects (Burtch et al., 2013).

6.0 CONCLUSION

The government has identified Islamic finance and the digital economy as Key Economic Growth Activities (KEGA) to achieve its national commitment of making the country a nation of sustainable growth. The Malaysian government through its Shared Prosperity Vision 2030 (SPV 2030) has identified Islamic finance and the digital economy as Key Economic Growth Activities (KEGA) to achieve its national commitment of elevating the country to become a nation of sustainable growth while ensuring fair and equitable distribution, across income groups, ethnicities, regions and supply chain. In order to enhance the nation's prosperity while ensuring rakyat unity, the Tun Mahathir administration has committed to building resilient new key sectors including positioning the country as an Islamic Finance Hub 2.0.

This is a strategic move leveraging on Malaysia's well-established global leadership in Islamic finance, a culmination of decades-long strong top-down approach and clear vision, while taking advantage of the digital revolution in recognition of the transformative value the digital economy could play in the country's overall economic growth. Malaysia could effectively champion the Islamic fintech agenda. These recommendations represent insights gathered at the inaugural MDEC Islamic Fintech Dialogue, organized by the Malaysia Digital Economy Corporation (MDEC), which welcomed regulators as well as industry stakeholders across different sectors with direct interest in the Islamic finance space (Suriani, 2019).

REFERENCES

- Adiansah, W., Mulyana, N., & Fedryansah, M. (2016). Potensi crowdfunding di Indonesia dalam praktik pekerjaan sosial. In *Prosiding Penelitian & Pengabdian Kepada Masyarakat* (Vol. 3, pp. 230–236). Retrieved from <https://doi.org/10.24198/jppm.v3i2.13655>.
- Agerfalk, P.J. & Fitzgerald, B. (2008). Outsourcing to an unknown workforce: Exploring open sourcing as a global sourcing strategy. *MIS Quarterly*, 32(2), 385–409.
- Agrawal, A., Catalini, C., & Goldfarb, A. (2010). The geography of crowdfunding (NET Institute Working Paper No. 10-08). doi:10.2139/ssm.1692661
- Agrawal, A., Catalini, C., & Goldfarb, A. (2015). Crowdfunding: geography, social networks, and the timing of investment decisions. *Journal of Economics and Management Strategy*, 24(2), 253–274.
- Ahlers, G. K., Cumming, D., Günther, C., & Schweizer, D. (2012). Signaling in equity crowdfunding. doi:10.2139/ssm.2161587 Asian Institute of Finance, 2014. Asian Link: Industry Outlook 2014.
- Ahlstrom, D., Cumming, D., & Vismara, S. (2018) New methods of entrepreneurial firm financing: Fintech, crowdfunding and corporate governance implications. *Corporate Governance: An International Review*, 310–313.
- Beck, T., & Demirgüç-Kunt, A. (2006). Small and medium-size enterprises: Access to finance as a growth constraint. *Journal of Banking & Finance*, 30(11), 2931–2943. doi: 10.1016/j.jbankfin.2006.05.009
- Belleflamme, P., Lambert, T., & Schwienbacher, A. (2014). Crowdfunding: Tapping the right crowd. *Journal of Business Venturing*, 29 (5), 585–609. doi:10.1016/j.jbusvent.2013.07.003
- Biancone and M. Radwan, "Social Finance and Unconventional Financing Alternatives: An Overview," *Eur. J. Islam. Finance*, vol. 0, no. 10, Jul. 2018.
- Biancone and M. Radwan, "Social Finance and Financing Social Enterprises: An Islamic Finance Prospective," *Eur. J. Islam. Finance*, vol. 0, no. 0, Feb. 2019.
- Biancone, P. Pietro, & Secinaro, S. (2016). the Equity Crowdfunding Italy : a Model Sharia Compliant. *European Journal of Islamic Finance*.
- Blohm, I., Leimeister, J. M., & Krmar, H. (2013). Crowdsourcing: How to benefit from (too) many great ideas. *MIS Quarterly Executive*, 12(4), 199–211.
- Brenner, W., Karagiannis, D., Kolbe, L., Krüger, J., Leifer, L., Lamberti, H.-J., et al. (2014). User, use & utility research. *WIRTSCHAFTSINFORMATIK*, 56(1), 65–72. doi:10.1007/s11576-013-0394-y
- Burtch, G., Ghose, A., & Wattal, S. (2013). An empirical examination of the antecedents and consequences of contribution patterns in crowd-funded markets. *Information Systems Research*, 24(3), 499–519.
- Calveri, C. & Esposito, R. (2013). *Crowdfunding World 2013: Report, Analysis & Trends*. DeRev.

- Chesbrough, H. W. (2006). *Open innovation: The new imperative for creating and profiting from technology*. Harvard: Harvard Business School Press.
- D. Cumming (Ed.), *The Oxford handbook of entrepreneurial finance* (pp. 369–391). Oxford: Oxford University Press.
- Drake, D. (2014). Crowdfunding: It's No Longer a Buzzword. Available at: <http://www.crowdsourcing.org/editorial/crowdfunding-its-no-longer-a-buzzword/32268>
- Dunkley, E. (2016). Crowdfunding rides to the rescue of many SMEs. *Financial Times*. Available at: <https://www.ft.com/content/a1b69b96-475b-11e5-a2f4d6e0e5eda22>.
- Eldridge, D, Nisar, T.M & Torchia, M. (2019). What impact does equity crowdfunding have on SME innovation and growth? An empirical study. *Small Business Economics*, <https://doi.org/10.1007/s11187-019-00210-4>
- Freedman, B. D. M., & Nutting, M. R. (2014). *A Brief History of Crowdfunding*.
- Gerber, E.; Hui, J.; and Kuo, P.-Y. 2012. Crowdfunding: Why people are motivated to participate. Technical Report 12-02, Northwestern University Segal Design Institute.
- Grivenics, D., Spovier, D., Zwimpfer, C., Domberger, R. & Hil, D. (2014). Crowdfunding IT research and business ideas: Predicting the chances of success of a crowdfunding project.
- Gros, D. (2016). How would Brexit affect finance for SMEs? *The Guardian*. Available at: <https://www.theguardian.com/smallbusiness-network/2016/apr/05/how-would-brexit-affect-finance-for-smes>.
- Haas, P., Blohm, I., & Leimeister, J. M. (2014). An empirical taxonomy of crowdfunding intermediaries. *Hemer, J. (2011). A snapshot on crowdfunding* (No. R2/2011). *Arbeitspapiere Unternehmen und Region*.
- Haniff, W. A. A. W., Halim, A. H. A., & Ismail, R. (2019). Equity Crowdfunding in Malaysia: Legal and Sharia Challenges. *International Journal of Asian Social Science*, 9(8), 450-460.
- Hornuf, L., & Schmitt, M. (2016). Success and failure in equity crowdfunding, CESifo DICE Report, ISSN 1613-6373, ifo Institut - Leibniz-Institut für Wirtschaftsforschung an der Universität München. München, 14(2), 16–22.
- Howe, J. (2006). The rise of crowdsourcing. Retrieved June 10, 2014, from <http://archive.wired.com/wired/archive/14.06/crowds.html> Irfan, M. (2016). Crowdfunding sebagai pemaknaan energi gotong royong terbaru. *Share: Social Work Jurnal*, 6(1), 30–42.
- Irfan, M. (2016). Crowdfunding sebagai Pemaknaan Energi Gotong Royong Terbaru. *Share: Social Work Journal*, 6(1).
- Leimeister, J. M. (2012). Crowdsourcing: Crowdfunding, crowdvoting, crowdcreation. *Zeitschrift für Controlling und Management*, 56, 388–392.
- Malone, T. W., Laubacher, R. J., & Johns, T. (2011). The big idea: The age of hyperspecialization. *Harvard Business Review*, 89(7/8), 56–65.
- Marzban and M. Asutay, (2017). Shariah-compliant Crowd Funding: An Efficient Framework for Entrepreneurship Development in Islamic Countries,.
- Massolution. (2012). Crowdfunding industry report—market trends, composition and crowdfunding platforms. Retrieved May 18, 2014, from <http://www.crowdsourcing.org/document/crowdfunding-industry-report-abridged-version-market-trends-composition-and-crowdfunding-platforms/14277>
- Moritz, A., & Block, J. H. (2014). Crowdfunding und Crowdfunding: State-of-the-Art der wissenschaftlichen Literatur [Crowdfunding and Crowdfunding: A Review of the Literature]. *ZfKE—Zeitschrift für KMU und Entrepreneurship*, 62, 57–89. doi:10.2139/ssrn.2274141 Secinaro, Equity crowdfunding Sharia compliant. Turin: Giappichelli, 2017.
- Mitra, T., & Gilbert, E. (2014, February). The language that gets people to give: Phrases that predict success on kickstarter. In Proceedings of the 17th ACM conference on Computer supported cooperative work & social computing (pp. 49-61).
- Mollick, E. (2014). The dynamics of crowdfunding: An exploratory study. *Journal of business venturing*, 29(1), 1-16. Leimeister, J. M. (2010). Collective intelligence. *Business & Information Systems Engineering (BISE)*, 4(2), 245–248.
- Paschen, J. (2017). Choose wisely: crowdfunding through the stages of the start-up life cycle. *Business Horizons*, 60(2), 179–188.
- Pierrakis, Y., & Collins, L. (2013). Crowdfunding: A New Innovative Model of Providing Funding to Projects and Businesses. *SSRN Electronic Journal*. <https://doi.org/10.2139/ssrn.2395226>
- Pisano, G.P. & Verganti, R. (2008). Which kind of collaboration is right for you? *Harvard Business Review*, 86(12). Retrieved on 19th June 2016 from: <https://hbr.org/2008/12/which-kind-of-collaboration-is-right-for-you>.
- Poetz, M.K. & Schreier, M. (2012). The value of crowdsourcing: Can users really compete with professionals in generating new product ideas? *Journal of Product Innovation Management*, 29(2), 245-256.
- Powers, T. V. (2012). SEC regulation of crowdfunding intermediaries under Title III of the JOBS Act. *Banking & Financial Services Policy Report*, 10(31), 1-7.
- Rossi, M. (2014). The new ways to raise capital: an exploratory study of crowdfunding. *International Journal of Financial Research*, 5(2), 8.
- Saeed, *Islamic Banking and Interest: A Study of the Prohibition of Riba and Its Contemporary Interpretation*. BRILL, 1996.
- Schwiebacher, A., & Larralde, B. (2012). Crowdfunding of small entrepreneurial ventures. In Sheela and I. Rahmah, 2017. *E-commerce contracts for sale of goods and consumer protection*. Bangi: Penerbit Universiti Kebangsaan Malaysia.
- Sheela and I. Rahmah, 2017. *E-commerce contracts for sale of goods and consumer protection*. Bangi: Penerbit Universiti Kebangsaan Malaysia
- Stanko, M., & Henard, D. (2016). How crowdfunding influences innovation. *MIT Sloan Review*, 57(3), 15–17.
- Surina Shukri, (2019). Malaysia Digital Economy Corporation (MDEC), MDEC Islamic Fintech Report.
- Surowiecki, J. (2004). *The wisdom of crowds: Why the many are smarter than the few and how collective wisdom shapes business, economies, societies, and nations*. New York: Doubleday Books.
- Vismara, S. (2016). Equity retention and social network theory in equity crowdfunding. *Small Business Economics*, 46(4), 579–590.
- Zainudin Awang, Abu Shams Mohammad Mahmudul Hoque, Habsah Muda and Fauzilah Salleh. (2017). The effects of crowdfunding on entrepreneur's self-belief. *International Academic Conference on Business and Economics (IACBE 2017)*.

THE IMPACT OF COVID-19 ON ISLAMIC BANKING IN INDONESIA DURING PANDEMIC ERA

Zulfikar

Department Syariah and Economics Academy of Islamic Studies University of Malaya

ABSTRACT

The impact of COVID-19 for Islamic banking can analyze into three risks that will be faced, such as financing risks, impairment of assets, and tightening the profit-sharing system. Islamic banking will be more flexible in meeting the economic crisis caused by the COVID-19 pandemic compared to conventional banks. Meanwhile, the national banking system predicted to experience trouble due to the COVID-19 epidemic, Islamic banks have advantages with the theory of profit-sharing to be one level more potent in dealing with crises. Superiority throughout these challenging times will undoubtedly be an excellent opportunity to strengthen the Islamic banks' *market share*. Comprehending three risks such as lending, a deterioration in asset quality and tightening of profit sharing, which will be faced by Islamic banking above, Islamic banks must be observant to ascertain the plan amid the COVID-19 pandemic. Carrying out restricted expansion into the digital share is a quite challenging decision that can be practised by Islamic banks.

Keywords : COVID-19, Islamic banking, financing, assets, profit-sharing

JEL Classifications: E50, G32, G12.

1.0 INTRODUCTION

The stretch of Islamic banks is a sign of the renewal. Almost all sectors label products with sharia; banking is no exception. Considering the sharia banking law approved in 1992, the liveliness of sharia banking in Indonesia has accelerated, unexpectedly when the 2008 global financial crisis. At the same time, a new law on sharia banking progressed. OJK (2019) reported 202 Islamic financial institutions consisting of 14 Islamic commercial banks, 168 Islamic Sharia credit banks, and 20 Islamic business units. Progress raised is considerably boosting in courses of quantity, but it is still uncertain how it will play a role in economic development in Indonesia.

OJK data (2019) records that the profit of sharia commercial banks in 2016 amounted to 3,442 billion, in 2017 amounted to 4,032 billion, in 2018 amounted to 5,757 billion. As of September 2019, the profits of sharia commercial banks amounted to 7,833 billion. The data explains that Islamic commercial banks are quite encouraging because the benefit aims obtained increase, although in terms of numbers do not expect anything at the macro rule.

Additionally, in phases of profit and loss, the OJK (2019) recorded 952 million in 2016 and 2019 amounting to 2,962 billion. The earning asset side as of December 2016 was 3.50%, in 2017 was 3.57%, and in 2018. The data exposed fluctuations. OJK (2019) also reported the contribution of Islamic commercial banks in terms of financing or terms of conventional banks known as lending, wherever the total funding in 2016 relinquished 177,482 billion with an NPF level of 7,834. In contrast, in 2017, the total financing was 189,789 billion and NPF amounting to 9,030, and the overall funding in 2018 is 202,298, and the NPF level is 6,597. Of the various funding provided, the portion or user of financing is dominated by the MSME sector with total funding of 248 billion in 2016, in 2017 amounting to 286 billion, in 2018 amounting to 320 billion, and in September 2019 amounting to 344 billion. The arrangement of a financing is quite right; from year to year stretches to expand. Even though the amount is nevertheless far of the word to create, though at least slowly, the role of Islamic banking proceeds to contribute. Nevertheless, the Financial Services Authority (FSA) showed the fullness of the national Islamic financial industry until May 2019 of 11.25%, decreasing related to the end of 2018 of 13.98%. The financial regulator blueprints the value of the Islamic capital market up to the same period reaching Rp 727.08 trillion, INKB of Rp 100.49 trillion, and total banking assets of Rp 484.62 trillion. The sharia banking market share currently reaches 5.85% of the overall banking industry. Preserve the fullness of Islamic banking, and it is essential to produce a roadmap of Islamic banking—this roadmap exacted to answer strategic issues, such as technology and digitalization. The effect of technology and HR competition (Human Resources) will be of matter. Furthermore, in terms of technological opportunities and digitalization.

Figure 1.0: Sharia Financial Industry Assets as of January 2019

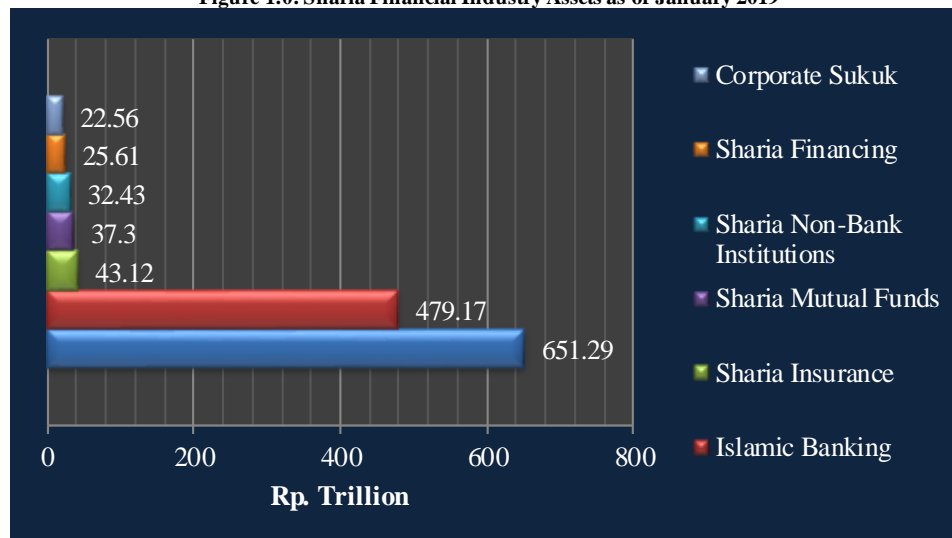

Sources : Financial Services Authority

The Islamic finance industry in Indonesia maintains to improve. The total assets of the sharia financial industry, according to the Financial Services Authority (OJK) relinquished Rp 1,291.48 trillion as of January 2019. The value of these assets increased by Rp 25.5 trillion compared to the September 2018 position of Rp 1,265.97 trillion. The sharia financial industry asset dominated by state Sukuk of IDR 651.29 trillion or 50.4%. In the second place, Islamic banking assets amounted to 479.17 trillion or 37.1%. In the third position, Islamic insurance assets reached Rp 43.12 trillion or 3.34%. In the fourth position, there were Islamic mutual funds valued at Rp 37.3 trillion or 2.89% and attended by sharia non-bank institutions assets Rp 32.43 trillion or 2.5%, sharia financing Rp 25.61 trillion or 1.99%, and corporate Sukuk Rp 22.56 trillion or 1.78%. The prudence of the assets of the Islamic financial industry does not involve the market capitalization of Islamic shares deserving Rp 3,861.7 trillion.

The performance of sharia banking in the world again tested with a pandemic that is mopping across the globe, namely COVID-19, wherever all sectors supporting the country's economy underwent a quite slap, including Indonesia. The appearance of Islamic banking during March to May experienced some quite severe problems, such as the termination of financing to customers. Moreover, the impact of Indonesia GDP growth in the first quarter of 2020 fell to 2.97% compared to the first quarter of 2018. Changes in economic behaviour showed an increase in poverty and unemployment and thus required more social safety net funds. The expenditure and financing budget for handling the impact of COVID-19 for allocation of health funds amounting to Rp75 trillion, the social safety net of Rp110 trillion, tax incentives and stimulus for Small and Medium Enterprises (MSEs) of Rp70.1 trillion, the economic recovery of 150 trillion.

In the Sharia microfinance sector, the impact can be seen in the deterioration in liquidity and the appearance of withdrawal of deposits by members, impeded repayment of financing, due to decreased income, blocked production, impeded the distribution of raw materials and products. Therefore, the policy recommendations accepted are relaxation for funding, liquidity bailout, provision of new working capital, companion of the Sharia Microfinance Institution (IKMS), recapitalization of Sharia cooperatives, tax relief, and social assistance for members of the Sharia Microfinance Institution.

In the Islamic banking sector eight items were affected, namely financing growth, Financing to Deposit Ratio (FDR), Capital Adequacy Ratio (CAR), liquidity, Net Interest Margin (NIM), asset quality, operations, and customer relationships. Regulators have issued policies, such as the OJK restructuring credit and relaxing the submission of periodic reports; Bank Indonesia gave a 50 bps rate reduction to 4.5%. Meanwhile, the Indonesia Deposit Insurance Corporation reduced the payment of insurance premiums starting in July 2020. Islamic banks are very vulnerable to liquidity shocks due to low care deposits and high cost of funds. With the profit-sharing funding based product, Islamic banks already have natural hedging, when the cost of funds adjusts the income of Islamic banks. The positive side of COVID-19 towards sharia economy and finance, is the opportunity for the emergence of values, positive encouragement and increased religious awareness and the importance of the halal and thoyyib lifestyle, increased business opportunities (e-commerce), positioning and implementation and sharia economic integration models.

In the sharia non-bank financial services sector, it seems that the average loss experienced by the insurance industry globally is 35% of market capitalization. The challenges that have experienced, namely claim operations, pricing/underwriting, customer support operations, loss estimation/actuarial reserving, marketing, also legal. Succeeding the impact of COVID-19 for the Islamic financial industry, especially Sharia non-bank commercial service institutions, including implementing a policy to utilize the OJK countercyclical policy accurately, servicing premium and reserve calculations (estimated losses), conferring responsibility for limiting premium payments, strengthening internal systems focus on stability, solvability, cashflow, and the strengthening of digital methods. From the research that I will do, I want to see what are the impacts that will be faced by the banking sector, especially Islamic banking and how management in Islamic banking makes policies to maintain bank performance.

2.0 LITERATURE REVIEW

Research on the impact of COVID-19 is still very little because this pandemic only occurred in 2020, which affected banks throughout the world, including Indonesia. Before COVID-19, there are several viruses like HIV SARS in the 2000s, the H1N1 Flu 2009, Ebola 2014 and the Zika virus in 2016. Furthermore presently COVID-19 which has deadened various sectors. Looking at some of the epidemics that occur in this world, of course, the banking sector including Islamic banking makes a variety of regulations and regulations that will continue to make the performance of Islamic banking remain functional during this pandemic.

The crisis in Indonesia that transpired during the Covid-19 pandemic was different from 1998 and 2008. In the time before the epidemic occurred, world economic growth, including Indonesia in early 2020 was better than last year. Nevertheless, when China started the COVID-19 outbreak in the city of Wuhan, the entire world economy, including the financial markets, collapsed. The first step to solve this problem that obviously must address first is by building infrastructure inside the hospital, including personal protective equipment (PPE), doctors, nurses, health workers. China is a country that is a global component supplier by 20%. If China cannot produce, global production is also affected, or there is a problem called supply shock. For example, Indonesia cannot make goods because the components come from China. At the same time, China, as a product centre in Asia, demands raw materials and supporting materials from various countries in Asia. China necessitates imports of palm oil, coal from Indonesia. If China experiences an outbreak, there will automatically be no more demands for the goods to Indonesia. That makes the prices of the two products decline, due to the inadequacy of exports to China decreased need.

At present, the ratio of the value of exports to Indonesia's GDP is only 32%. So, the only thing that can stimulate our economy is domestic. If our local hit, the economy will also be hit. Based on current data, our economy only increased by 2.97% in the first quarter, and if this COVID-19 could conclude in June, the economic recovery could be in the form of V.

The current global situation is still more severe because various countries in the world have to do social distancing or lockdown to break the COVID-19 chain. The principle of economic exercise is a market that can exchange goods and services transactions, both physical and virtual/online. The assumption is that all businesses that require demands by producing people together physical will be interested, such as the tourism industry, hospitality, manufacturing, and so on that cannot be done virtually / online. Furthermore, people told to stay at home or social distancing, which can create people not to be able to work to meet their daily needs. To be able to meet their needs, people need to given social support not because they are vulnerable, but because they no longer have income or do not work. The scale of social safeguard must be more extensive than the well-being of the poor. Management options that can be implemented by the government are to serve the community in the form of social protection such as through cash assistance (BLT), cash transfers, conditional cash transfers, and cash for training.

On the other hand, the government is springing a Pre-Employment card program, which can be moreover appropriated by people who are put off or laid off or unemployed. For any people, some do not like the job training that carried out online, because they think there is no point. The shows the need for a selection device, who deserves or does not deserve to be used as a benchmark, whether they have the right or not to be given Direct Cash Assistance funds. The different thing is, the government can provide relief for companies that cannot pay taxes, payments or credit and employee payrolls.

The case of the spread of COVID-19 can then see from two different economic perspectives, namely demand and supply. On the demand view, the state of the COVID-19 pandemic will decrease the consumption sector, travel and transportation activities, and increase transportation and trade costs. While on the supply view, it is most acceptable what ensued was a contraction in worker/labour productivity, decreased investment and funding activities, and splitting of the global supply chain (*global value chain*).

On the consumption view, the pattern of public consumption due to the spread of COVID-19 will automatically improve. People will serve not to travel, or tourism and are more willing to increase the effectiveness of necessities which are supposed necessary in contemplation of restrictions on human movement. Overall, the rate consumption will conduce to occur due to distorted prices due to the high costs of transportation and logistics of goods.

Meantime, in phases of production, several major sectors in Indonesia will also be affected by the spread of COVID-19, unusually the manufacturing industry. The increase of this sector is considered significant to the Indonesian economy (19-20 per cent), and products starting from the manufacturing industry further provide significantly to Indonesia's total exports, which is over 70 per cent. The performance of the manufacturing industry in Indonesia is feasible to reduce down along with the increasing cases of COVID-19. Here is because the majority of manufacturing industries in Indonesia still depend on imports, one of which comes from China. Production activities in China too concerned due to cases of this virus. It should note that the structure of Indonesia's imports admittedly overshadowed by raw/auxiliary materials whose figures reach above 70 per cent. Simalakama fruit between structures these exports and imports are likely to have a significant impact on the performance of the manufacturing industry in Indonesia.

In general, the impact of COVID-19 is indeed considerably significant on the Indonesian economy. As illustrated above, the slowdown in the performance of the manufacturing industry, brought by the still slowing global economy, which has an impact on demand decline, insistence automatically decrease Indonesia's export performance. China, for the next few quarters, seems to be going experiencing economic contraction where production activities and productivity are likely to reduce by 20-25 per cent. Therefore that the China economy assumed to only grow in the range of 5 per cent, that condition will have a significant impact on Indonesia's trade performance this year. The global supply chain will disorder due to the perversion of the China economy due to COVID-19. Indonesia needs to find sources of raw materials or capital goods from other countries, although it is not accessible and the price is higher. China's economic slowdown also needs to be a force for Indonesia to optimize its potential in the country. It expected to become an alternative production hub that can contribute to the global supply chain.

Meanwhile, the affairs of the sharia banking industry, the emergence of sharia banking in Indonesia is the real fascination of Indonesian people who require to administer their financial transactions following sharia. Although it is different from neighbouring countries where the government initiated the emergence of their Islamic finance industry, the growth of Islamic banks in Indonesia is not straightforward because the support of the government is still very wanting. In early 2019 after 28 stands, the market share of Islamic banks in Indonesia only reached 5 per cent. That is inversely comparable to neighbouring Malaysia, at present, the market share of Islamic banking in Malaysia has reached 35 per cent more. Even the State Bank of Malaysia has set a target by the end of 2020, the market share of Islamic banking in the twin tower country at 40 per cent. Likewise, if we compare it with Oman still those who have just started their Islamic banking operations in early January 2013 based on Royal Decree No. 69 In 2012, their Islamic banking market share had touched 14 per cent in early 2020. Bank Central Oman is targeting the Islamic banking market share at 10 per cent in 2021.

Islamic banks are unique compared to conventional banks. The main difference between conventional and Islamic banking is the ban of usury (interest) in Islamic banking. As a replacement for the interest mechanism, Islamic banks implement a system of profit-sharing, buying and selling and leasing. The uniqueness makes Islamic banks have several advantages if compared to conventional banks. In large Islamic banks, the ratio agreed upon at the start of the contract is in the profit-sharing system; this is what distinguishes it from conventional banks. "Interest rates at conventional banks can change according to interest rates at Bank Indonesia (BI). Whereas in Islamic banks, the profit-sharing is applied by the agreement at the beginning of the contract.

The quantity of profit from an Islamic bank depends on the benefit realised from the bank; the ratio will increase along with the improvement in earnings of the Islamic bank. That is different from conventional banks. The interest earned by conventional bank customers heated even though the bank is getting high or low profits. In ingenuous language, if in reasonable economic conditions the Islamic bank arranges a significant profit from the distribution of financing because the business customers are likewise competent at the saver customers will get a real benefit as well because it uses a profit-sharing system. Conversely, if the economic conditions are not good, such as the COVID-19-19 pandemic, which results in a decrease in income, the bank's obligation to provide profit sharing to depositors will adjust.

3.0 RESEARCH METHODOLOGY

This study uses qualitative methods. The purpose of using this method is to capture value or view represented by experts and practitioners of Islamic banking. Qualitative study is a process or effort to understand scientific problems based on a complex overall picture, through information reported from the informant's viewpoint and carried out in natural situations (Sugiyono, 2005: 1). The method with a qualitative approach to this study is to review the literature or literature review from a variety of writing, research documents, and previous studies that are following the theme of this study.

4.0 LIMITATION OF RESEARCH

I limit this research by looking at the consequences effected by the appearance of the COVID-19 pandemic during the last three months, from March, April and May 2020. Furthermore, it will compare the performance of Islamic banking in Indonesia during the COVID-19 epidemic and before the presence of this virus.

5.0 RESULTS AND DISCUSSION

The excellent news for the growth of Indonesian Islamic banking as surely appeared at the end of October 2019. As if out of the affliction of a 5 per cent market share since 2014, as of October 2019 the Indonesian Islamic banking market share was capable of breaking the 6 per cent figure based on data from the Financial Services Authority (OJK) or around IDR 513 trillion. The common significant shielding factor of managing this market share was due to enhancing the growth of Islamic banking assets in the BUS and UUS units by 10.15 per cent compared to Rp 499.98 trillion.

In terms of financing growth, Islamic banks were able to accomplish double-digit growth of 10.52 per cent compared to Rp 345.28 trillion and an increase in third-party funds (DPK) to Rp 402.36 trillion. At present, the sharia banking market share in Indonesia dominated by 14 Sharia Commercial Banks (BUS) or around 65 per cent, while 32 per cent of the sharia banking market share controlled by 20 Sharia Business Units (UUS) and the base controlled by 165 Sharia Rural Banks (BPRS).

Figure 2.0: Islamic Bank Assets

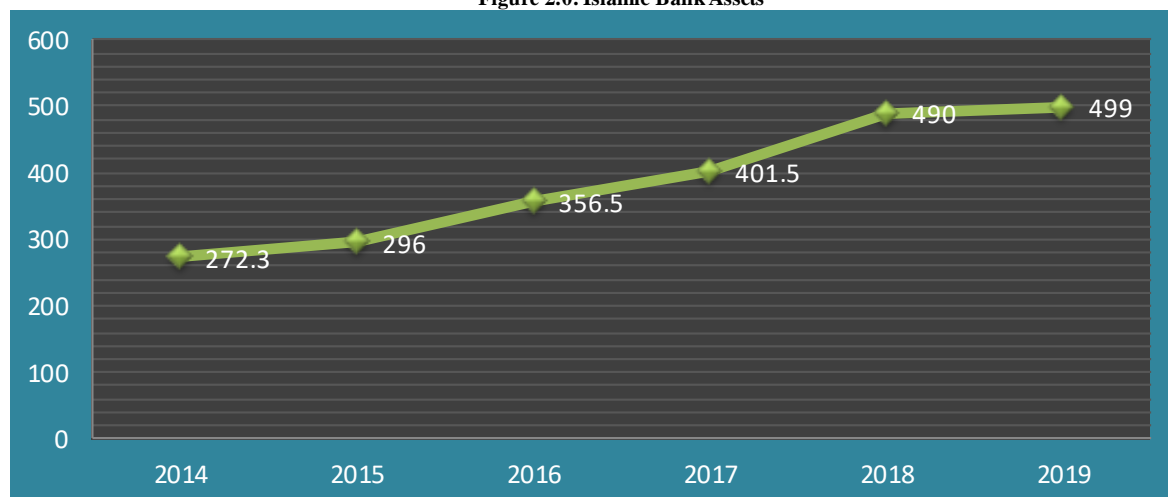

Source : Financial Services Authority

The total assets of Islamic banks in November revealed through IDR 400 trillion for the first time. Sharia Banking Statistics Services Authority Finance (OJK) noted that Islamic banks' assets in November 2017 grew 12.6% to Rp 401.45 trillion from the final position previous year.

However, behind the considerably good growth of sharia banking over the past five years, growth in sharia banking will experience a downturn in 2020 due to the spread of the coronavirus. Some large cities, in particular, have imposed Large Scale Social Restrictions (PSBB) to reduce the spread of this virus. As a result, many offices, shops and factories must carry out work from home or stop operating temporarily.

Furthermore, the Indonesian government itself has announced a stimulus package worth Rp 405 trillion to deal with the impact of the expense of the coronavirus. To strengthen the central government, OJK also issued POJK No. 11 / POJK.03 / 2020 to provide relaxation for banking customers, including sharia banking, especially the ease of the

restructuring and rescheduling process for customers interested by the coronavirus spread, particularly micro, small and medium business (MSME) or non-MSME customers. Financing under Rp 10 billion, which depends on the policies of various Islamic bank. Precisely, customers who undeviatingly linked to the tourism, transportation, hospitality, trade, processing and mining sectors.

Before the spread of the coronavirus in Indonesia, Islamic banking expected to continue to record double-digit growth. Nevertheless, currently, Islamic banks must start developing their growth points due to the impact of the spread of COVID-19. Islamic banking additionally demanded to be able to give the best solutions to its customers, such as restructuring, additional financing periods, or provide a grace period of 3-6 months in the future. So that customers affected by this virus can feel the appearance of this sharia-compliant bank as a solution to the economic pressure.

Second, Islamic banking must also see the problem of the spread of that virus as a difficulty that must transform into an excuse to improve, especially from the aspect of digital services. The digital payment that can make it more transparent for customers to do all transactions in one application is a must owned by Islamic banking. We can see that many Islamic banks have invested billions and even trillions in improving their digital services.

The next challenge is how Islamic banking can turn this plague crisis into an opportunity for new financing in sectors directly related to medical devices such as hospital beds, masks, hospital ventilators, test kits, vaccines, hospital equipment, etc. In addition to helping medical staff, these devices are also able to withstand the spread of COVID-19. Therefore, it is time for Islamic banking to start revising their strategies, changing their budgeting, and planning things that are not desirable in the future if the spread of this virus prolonged to the end.

Three risks are looming over the banking industry during the COVID-19 pandemic, namely lending, a deterioration in asset quality and tightening of profit sharing.

Figure 3.0: The risks appear over during COVID-19

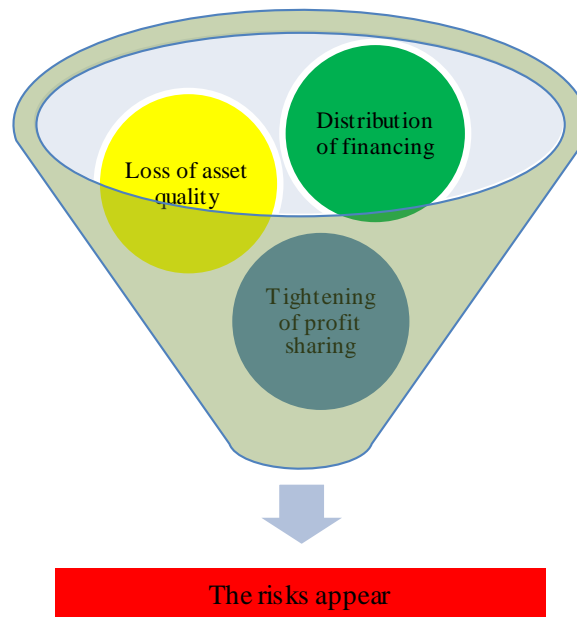

For the first risk, particularly lending (financing), Islamic banks, and conventional banks will experience the same contingencies. Both Islamic banks and conventional banks will encounter a slowdown in credit (funding). As for the other risk, namely, the decline in asset quality, both Islamic banks and conventional banks will be helped by the occurrence of POJK No.11 / POJK.03 / 2020. The POJK preference supports Islamic banks and conventional banks, unexpectedly in preparation for pay for earning assets losses. Islamic banks prognosticated to have an advantage compared to conventional banks at the third risk, namely tightening profit-sharing margins. Here is because Islamic banks use a profit-sharing system. Amidst a profit-sharing scheme, the situation of the balance sheet of the Islamic banks throughout the crisis due to the COVID-19 pandemic will be flexible because the number of posts reserved for the profit-sharing payment will also decrease with the decrease in income obtained by the Islamic bank. Here is separate from conventional banks where when interest credit income declines, a reduction does not follow it in interest costs for depositors, this will be an unreasonable problem of conventional banks.

Figure 4.0: Financing Profit Sharing BNI Syariah October 2019-April 2020

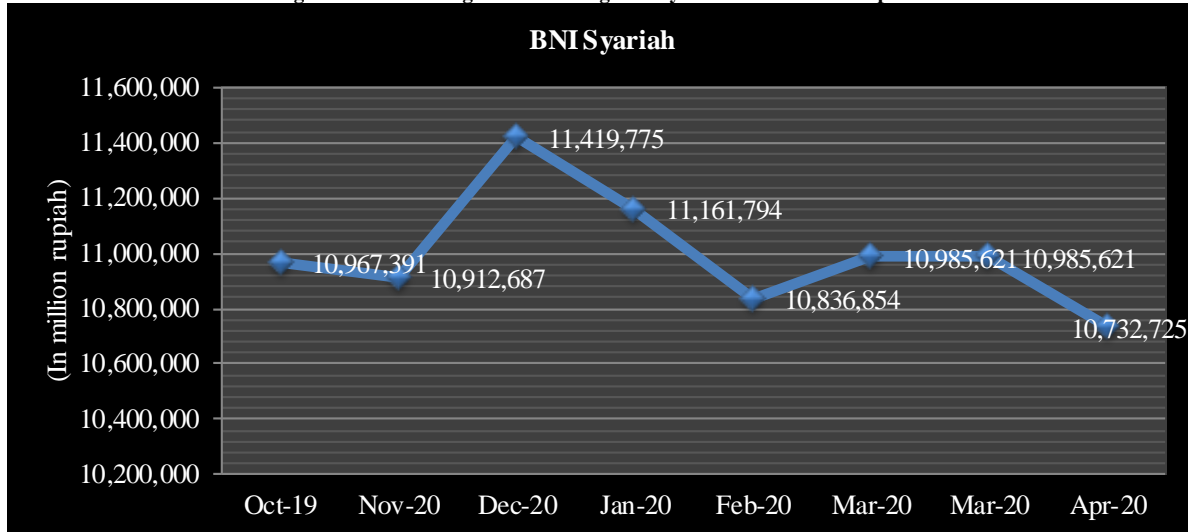

Source : Financial Report BNI Syariah

From the graph, I took BNI Syariah profit-sharing financing before and after the COVID-19 pandemic. December 2019, the highest funding profit-sharing, Rp. 11,419,775 (in millions), after the COVID-19 epidemic in April 2020 there was a decrease of Rp. 10,732,725 (in millions), we can analyze that there is an effect of COVID-19 with even a small share of profit sharing financing.

Figure 5.0: Financing Profit Sharing BSM October 2019-April 2020

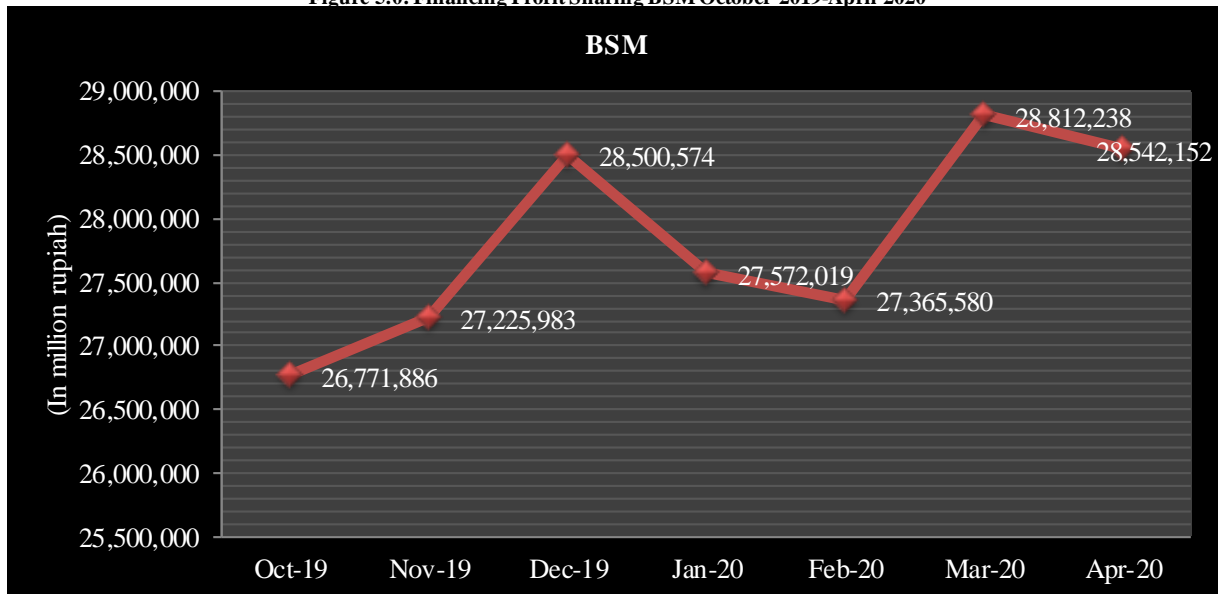

Source : Financial Report BSM

Bank Syariah Mandiri is an Islamic bank in Indonesia whose performance is quite good when compared to other Islamic banks. Furthermore, it can see that BSM profit-sharing financing has eclipsed 25 million rupiahs (in millions); this indicates that financing in BSM is good enough and can play with the banking system conventional. Moreover in March 2020 the highest profit-sharing financing compared to the previous month, whereas in March 2020 the COVID-19 pandemic in Indonesia is still tremendous and effective. Viewing at the graph above it can be discovered that BSM has quite good performance and can adapt to the current COVID-19 pandemic, although in April 2020 there was a drop of Rp. 270,086 (in millions).

Figure 6.0: Financing Profit Sharing BRI Syariah October 2019-April 2020

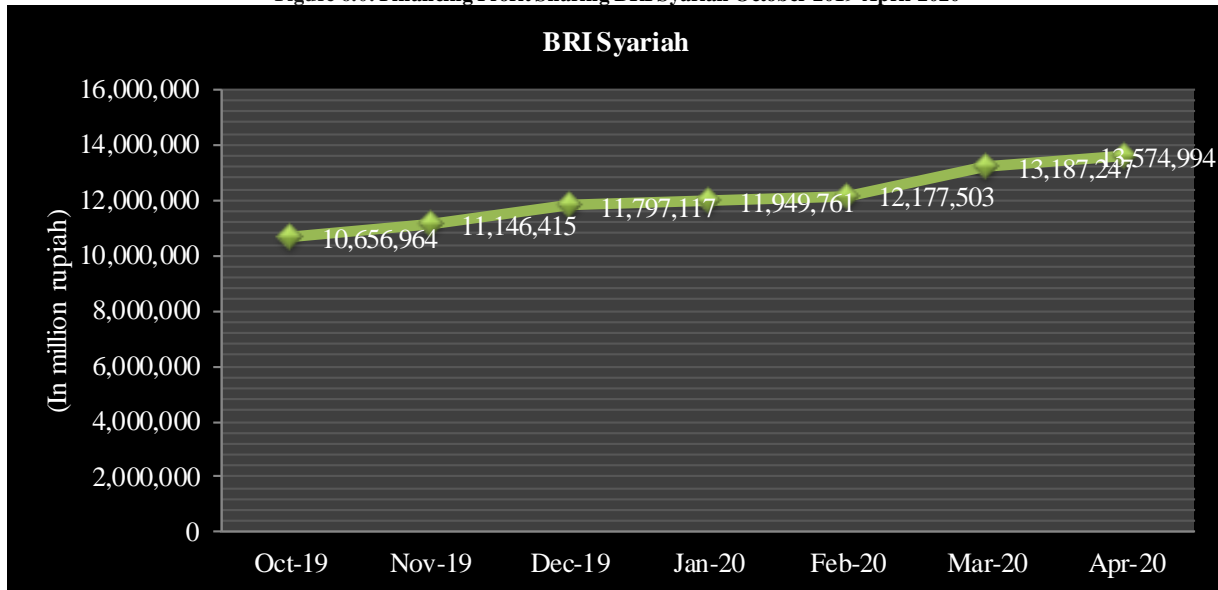

Source : Finacial Report BRI Syariah

From the graph above, we can see that BRI Syariah's profit-sharing financing performance is also considered stable, from October 2019 to April 2020, there has always been an increase, although just slightly. Before and after the COVID-19 pandemic every month, there was still an increase.

Figure 7.0: Financing Profit Sharing Mega Syariah October 2019-April 2020

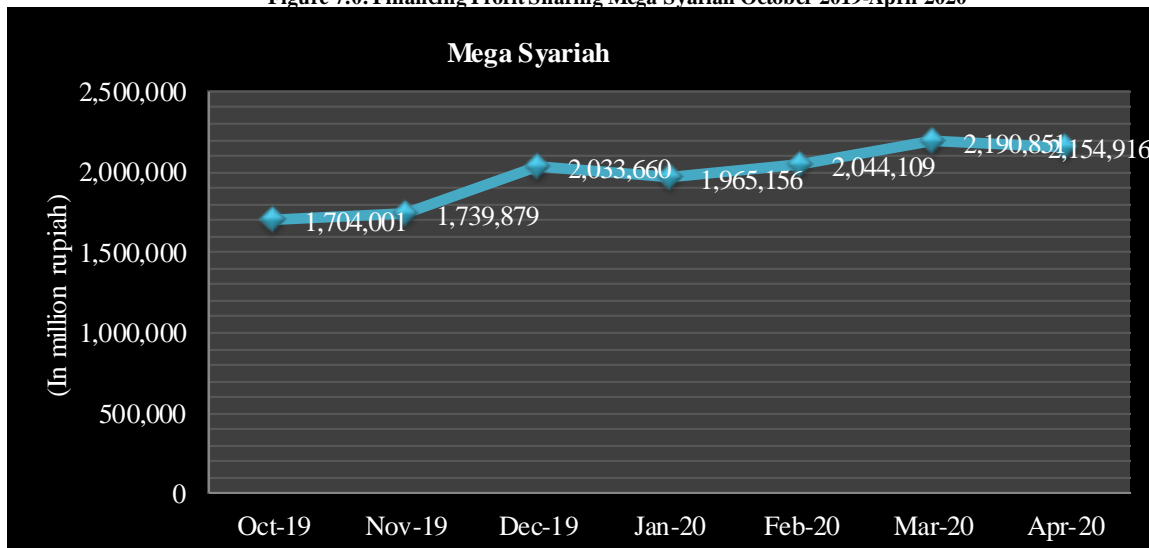

Source : Finacial Report Mega Syariah

Bank Mega Syariah if we see from the graph above, there is a fluctuation in profit-sharing financing between October 2019 to April 2020. Nevertheless, it can still maintain the company's performance remains outstanding. March 2020 financing sharing for Bank Mega Syariah valued at Rp. 2,190,851 (in millions), meaning that the pandemic during the COVID-19 performance of Bank Mega Syariah was still well maintained.

Figure 8.0: Financing Profit Sharing BCA Syariah October 2019-April 2020

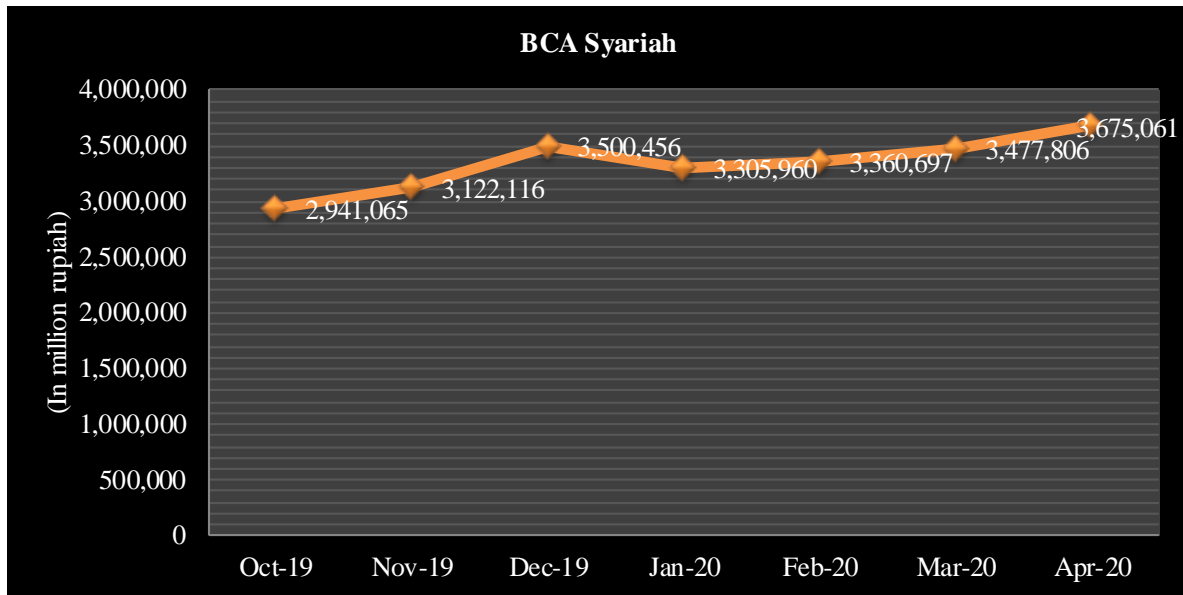

Source : Finacial Report BCA Syariah

BCA Syariah is further still in a position of maintained performance throughout 2020. Nevertheless, there are still many COVID-19 pandemics in Indonesia, and even in some provinces are implementing Large Scale Social Restrictions (PSBB) to decrease the spread of this virus. BCA Syariah has made several attempts and policies to remain to survive in the world of Islamic banking, and it has proven to maintain a positive trend during 2020, given its profit-sharing financing.

Figure 9.0: Financing Profit Sharing Bukopin Syariah October 2019-April 2020

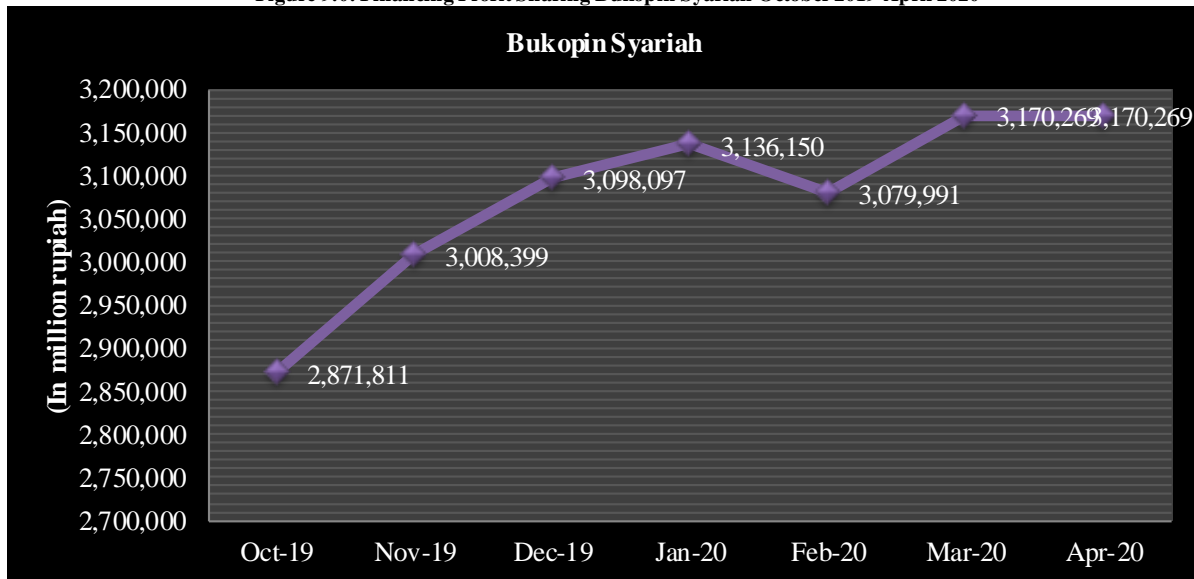

Source : Finacial Report Bukopin Syariah

When observed Bukopin Syariah is likewise quite interesting, because the trend of increased financing for the results is quite good from October 2019 to January 2020, and there was a decline in February 2020 and rose again in the subsequent month during the COVID-19 pandemic.

Figure 10: Financing Profit Sharing Bank Panin Syariah October 2019-April 2020

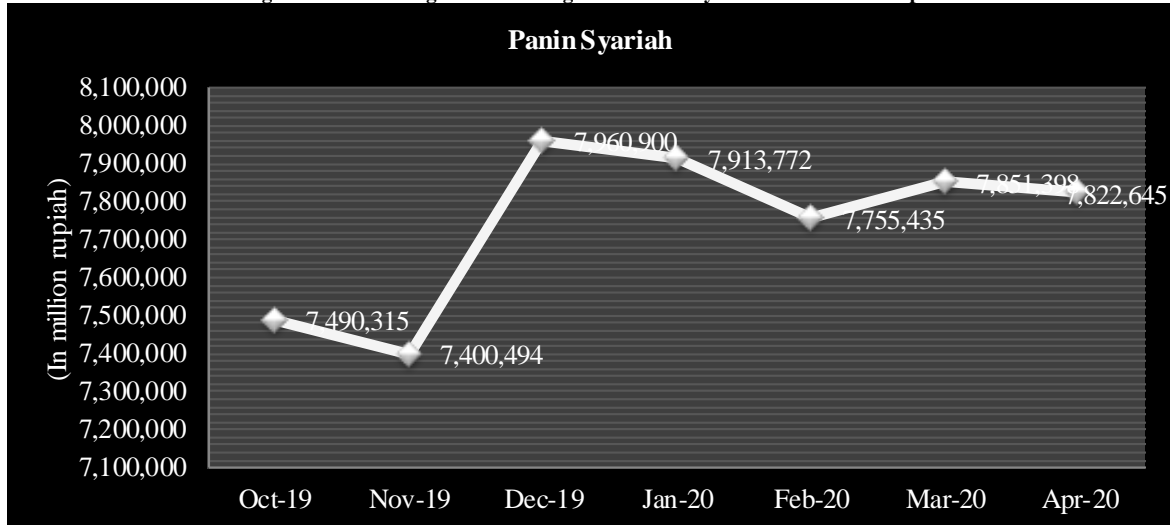

Source : Financial Report Panin Syariah

Bank Panin Syariah additionally extends to manage the performance of Islamic banking even though in November 2019 there was a decline and increased dramatically in December 2019. Yet it still retained the performance of its profit-sharing financing during 2020.

From the several explanations above from several decided Islamic banks in Indonesia, it can explain that the performance of profit-sharing financing in Islamic banking continues consistently despite the COVID-19 pandemic during 2020. Large-scale Social Restrictions (PSBB) implemented in practically every region of Indonesia do not make Islamic banks failed customers even though the management used attention with the current economy. Based on observations that I performed that the Financial Services Authority (OJK) has made Islamic banking policies in Indonesia has published several strategies to survive between the issue of the outbreak of COVID-19 in Indonesia. The Financial Services Authority (OJK) affords a stimulus for the national economy as a countercyclical policy on the impact of the spread of COVID-19. In addition to conventional banks, Islamic banks also set this rule to give a unique approach to financing customers affected by COVID-19.

BNI Syariah banks afford relief (restructuring) in the form of late payments to customers affected by COVID-19. The structure of the restructuring support presented will adapt to the conditions and kind of business of the customer. The restructuring can help facilitate customers in paying their obligations. This financing restructuring policy is because the spread of the COVID-19 pandemic has an impact on customer performance and capacity to increase financing risk. That has the potential to disorder banking performance and financial system resistance. This restructuring welfare policy applies to all customers in the consumer, productive, micro or BNI iB Hasanah Card segment. Customers who can receive proper handling for restructuring are those who are directly or indirectly affected by the spread of COVID-19 with specific guidelines.

In the COVID-19 pandemic, several potential risks will face by the banking sector, including credit risk, market risk, operational risk. Credit risk is the risk due to collapse of customers or other parties to meet obligations to banks by agreed agreements. In conventional banks, it called credit, whereas in Islamic banks it is better known as financing. During the pandemic, many bank customers experienced job losses due to social distancing and the implementation of Work From Home (WFH) in their companies. So they do not have the income to pay for credit/financing. Of course, this has an impact on the strike in credit/financing applications that transpire in Islamic banks and conventional banks.

The other risk is market risk, which is the risk where the balance sheet position changes in market prices created by exchange rates or interest rates. In this case, the tightening of net interest margins. At this risk, Islamic banks are more preferred because Islamic banks do not use the interest policy but instead use the profit-sharing arrangement. Therefore, while the COVID-19 pandemic, as it is now, the balance sheet of the Islamic bank will be flexible following changes in revenue sharing because income also changes. In contrast to conventional banks that utilize the interest system, if there is a decrease in interest income, credit is not followed by a reduction in interest costs for customers. That will be a critical problem encountered by conventional banks.

Third, operational risk is the risk experienced by Islamic banks and conventional banks in the form of an operational

slowdown. The slowing of operations included front office restrictions, restrictions on customers coming to banks, as well as cuts in operating hours and even branch closures by several Islamic banks.

Based on the risks faced during the COVID-19 pandemic, Islamic banks see as excellent. They expected to perceive opportunities from surviving threats to increase the market share of Islamic banking. One of them is by increasing digital marketing. The internet has become the essential thing that can utilize to be able to keep communicating and carrying out activities both educational, business and social.

6.0 CONCLUSION

From the various explanations above, it can be concluded that COVID-19 in Indonesia has provided different kinds of impacts that could sue the national economic system. Likewise, Islamic banking also gets an effect from the spread of COVID-19. Almost every Islamic banking makes various policies aside from stimulus assistance from the government. OJK has issued a National Economic Stimulus Policy As Countercyclical Policy due to the impact of the spread of COVID-19. The banking sector is the one that feels the effect. Unusually with the policy compared to the postponement of instalment payments for customers. That is an effort by the government to guarantee people's lives during the pandemic. Later there was a concern that the banking industry would experience a liquidity crunch that could cause a crisis in the banking sector. Liquidity crunch is a situation where the supply of cash coming into banks decreases dramatically, while at the same time, the demand will be even higher. The kind of situation can be caused by customers being unable to pay their debts or obligations to the Bank. As a result of the weakening of the people's economy so that people's income is reduced. Accordingly, the supply of cash available in banks will decline. Meantime, banks still have to pay off operational costs and pay the profit-sharing ratio to the owner of third party funds (DPK).

REFERENCE

- Bank for International Settlements. Reflections on regulatory responses to the Covid-19 pandemic. April 2020. <https://www.bis.org/fsi/fsibriefs1.pdf>
- Basel Committee on Banking Supervision. Measures to reflect the impact of COVID-19. April 2020. <https://www.bis.org/bcbs/publ/d498.pdf>
- Chattha, J. A. and Halim, W. N. Strengthening the Financial Safety Net: The Role of Shari'ah Compliant Lender-of-Last-Resort (SLOLR) Facilities as an Emergency Financing Mechanism. 2014. <https://www.ifsb.org/download.php?id=4405&lang=English&pg=/sec03.php>
- Chattha, J. A. Key Evolving and Emerging Regulatory and Supervisory Issues in Islamic Finance: A Global Perspective. February 2020b. <http://isfire.net/>.
- Chattha, J. A. The COVID-19 Pandemic: What Does It Mean for Islamic Finance? April 2020a. <http://isfire.net/>.
- Chattha, J.A., Alhabshi, S.M. and Meera, A.K.M. Risk management with a duration gap approach: Empirical evidence from a cross-country study of dual banking systems. 2020. <https://doi.org/10.1108/JIABR-10-2017-0152>
- Sari, M. D., Bahari, Z., & Hamat, Z. (2013). Perkembangan Perbankan Syariah di Indonesia: Suatu Tinjauan. *Jurnal Aplikasi Bisnis*, 3(2), 120-138.
- Setiawan, C., & Putri, M. E. (2013). Non-performing financing and bank efficiency of Islamic banks in Indonesia. *Journal of Islamic Finance and Business Research*, 2(1), 58-76.
- Shidiqi, K. A., & Rachmawati, A. (2018). Determinants of Sharia Banks' Efficiency In Indonesia: Panel Data Analysis. *Jurnal Ekonomi Pembangunan: Kajian Masalah Ekonomi dan Pembangunan*, 19(2), 186-195.
- Sudarsono, H., & Saputri, M. A. (2018). The Effect of Financial Performance toward Profit-Sharing Rate on Mudharabah Deposit of Sharia Banking in Indonesia. *Muqtasid: Jurnal Ekonomi dan Perbankan Syariah*, 9(1), 82-92.
- Suhardjanto, D., Dewi, A., Rahmawati, E., & Firazonia, M. (2012). Peran corporate governance dalam praktik risk disclosure pada perbankan Indonesia. *Jurnal Akuntansi dan Auditing*, 9(1), 16-30.
- Syukron, A. (2013). Dinamika perkembangan perbankan syariah di Indonesia. *Economic: Journal of Economic and Islamic Law*, 3(2), 28-53. <https://katadata.co.id/berita/2019/08/07/pertumbuhan-industri-keuangan-syariah-hingga-mei-2019-melambat>
- <https://www.bcasyariah.co.id/>
- <https://www.bnisyariah.co.id/id-id/>
- <https://www.brisyariah.co.id/>
- <https://www.feb.ui.ac.id/blog/2020/05/07/muhamad-chatib-basri-dampak-covid-19-bagi-perekonomian-indonesia-dalam-webinar-lembaga-psikologi-terapan-ui/>
- <https://www.mandirisyariah.co.id/>
- <https://www.megasyariah.co.id/>
- <https://www.ojk.go.id/id/Default.aspx>
- <https://www.ojk.go.id/id/kanal/syariah/berita-dan-kegiatan/publikasi/Documents/Pages/Snapshot-Perbankan-Syariah-Indonesia-Juni-2019/Snapshot%20Perbankan%20Syariah%20Juni%202019.pdf>
- <https://www.ojk.go.id/id/regulasi/Documents/Pages/Stimulus-Perekonomian-Nasional-Sebagai-Kebijakan-Countercyclical-Dampak-Penyebaran-Coronavirus-Disease-2019/pojk%2011-2020.pdf>
- <https://www.ojk.go.id/id/regulasi/Pages/Stimulus-Perekonomian-Nasional-Sebagai-Kebijakan-Countercyclical-Dampak-Penyebaran-Coronavirus-Disease-2019.aspx>
- <https://www.paninbanksyariah.co.id/>
- <https://www.syariahbukopin.co.id/>
- Riana, I. K. T., & Dewi, S. K. S. (2015). Peran EPS Dalam Memediasi Pengaruh ROE

VOLATILITY BEHAVIOUR OF SUKUK INDEX DURING CRISIS

Syazwani Abd Rahim

Academy of Contemporary Islamic Studies (ACIS), Universiti Teknologi MARA Johor (Segamat), Malaysia

Abstract

The objective of this study is to measure the performance of the selected Sukuk Index Dow Jones Sukuk Index (DJSI) in the face of the 2008 global financial crisis with trade-off risk and return by measuring the volatility behaviour as a risk proxy for the period under study. DJSI data has collected from the Bloomberg database from historical price daily data, 30/9/2005-12/5/2015 (2424 observations) except for Saturdays and Sundays. The methodologies used in the GARCH (Generalized Autoregressive Conditional Heteroskedasticity) model study. Applying the GARCH family model (GARCH, EGARCH, TGARCH, and PGARCH) may provide empirical analysis to forecast DJSI volatility. The researcher suggests policymakers to guide regulators, investors and issuers toward the best Sukuk that remained stable in a recession. This analysis will provide valuable information and guidelines for Islamic bonds to Sukuk issuers, policymakers, regulatory bodies and investors.

Keywords: Sukuk, Volatility, Sukuk Index, GARCH models, Financial crisis

1.0 INTRODUCTION

The paper provides a more detailed review to establish a better understanding of Sukuk, which remains the Islamic finance industry's most common financial instrument. The Sukuk market remained constant, and there were reasonably active Sukuk issuances on the established Sukuk market such as Malaysia, Saudi Arabia and the UAE. At the same time, Mali and Morocco are the two new jurisdictions that have issued Sovereign Sukuk to the domestic market (IIFM Sukuk Report 2019). Narrated by Al-Tirmidhi, Abu Daud and Al-Nasa'i, 'Abdullah bin' Amr said: 'The Messenger of Allah (peace be upon him) said: 'It is permissible to make a loan in combination with a sale, or to stipulate two conditions in one transaction, or to make a profit on something that is not under your control, or to sell something that you do not have.'

'Sukuk' is a classic Arabic word and the plural form of a term called 'sakk.' Sakk is a legal document or instrument that represents obligations under Islamic law or 'Shari'ah (Haider & Azhar, 2010). From an Islamic point of view, Sukuk's emergence is appropriately based on a hadith that explains the historical facts of this concept. Imam Malik's Al-Muwatta records a reference referencing the word Sukuk: "Yahya told me from Malik that he had learned that in Marwan ibn al-Hakam's time Sukuk was given to people for the al-Jar market goods. People had bought and sold the Sukuk among them before they delivered the goods. Zayd bin Thabit and one of the Companions of Rasulullah (saw) went to Marwan and said, "Marwan! Do you make usury permissible?" He said: "I seek refuge with Allah! What is that?" He said, "This Sukuk, which people buy and sell until they take delivery of the goods." So Marwan sent a guard to pursue them and keep them out of the hands of people and back to their owners. (Bank Islam Malaysia Berhad, 2012; Shahida & Sapiyi, 2013).

1.1 Definitions of Sukuk

Islamic finance and the financial markets have many international norm setters. One of them being the most significant are the Accounting and Auditing Organisation for Islamic Financial Institutions (AAOIFI) and the Islamic Financial Services Board (IFSB). The Securities Commission Malaysia (SC) guides Sukuk issuances in Malaysia. Sukuk is discussed in this section, based on Malaysia's Securities Commission for two main reasons. First, the definition of SC is considered, according to the literature, to be the most extensive and all-encompassing definition compared to other meanings. Second, Malaysia has recently been the principal driver of Sukuk issuance, and the pattern continues.

The Securities Commission Malaysia (2019) defines Sukuk as "certificates of equal value which evidence exclusive ownership or investment in the property using Shari'ah principles and concepts approved by the Shari'ah Advisory Council (SAC)." Meanwhile, the AAOIFI defines Sukuk as: "a certificate of equal value, representing undivided

interests in the ownership of the underlying assets (applicable to both tangible and intangible assets), usufruct, services, or investment, particularly ventures or some special investments” (AAOIFI, 2008). According to IFSB, Sukuk refers to: “a certificate that represents the holder’s proportionate ownership in an entire part of an underlying asset where the owner assumes all rights and obligations to such asset.”

1.2 Sukuk Structures

In recent decades, the preferred structures in both foreign and domestic Sukuk have been Murabahah and Wakalah modes, which is a shift from the preference for structures containing more tangible assets in earlier years (IIFM Sukuk Report, 2019). These preferences had contributed to the Sukuk market's growth. But the right diversification mix is created to build a more competitive market.

Abdel-Khaleq and Richardson (2007) noted that Sukuk structures vary from Sukuk Murabahah (trade with mark up or cost-plus sale), Sukuk Ijarah (rental or lease agreement) and Sukuk Musyarakah (profit and loss sharing). This research focuses on three types of Sukuk structures namely Murabahah, Ijarah and Musyarakah by 50 listed firms in Malaysia, although there are 14 types of Sukuk listed by AAOIFI (Noriza & Azhar, 2012). Securities Commission Malaysia (2019) categorized them as sale-based Sukuk, lease-based Sukuk and equity-based Sukuk. Figure 1 illustrates the different types of Sukuk based on Shari’ah contracts.

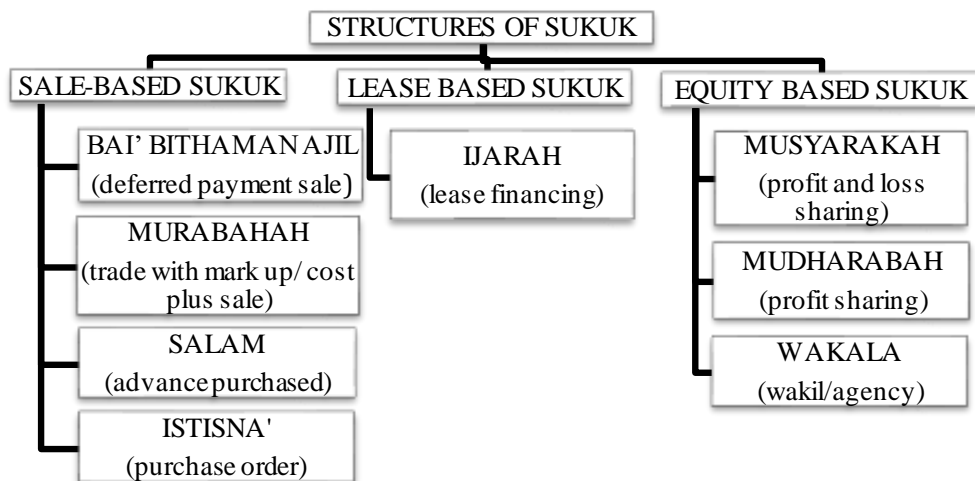

Fig. 1. Selected Structures of Sukuk Based on Shari’ah Contracts

Source: Securities Commission Malaysia 2019

Figure 1 shows eight types of structures of Sukuk which become common in Malaysia. The Malaysian Debt Securities Sukuk (2009) states that securities issued under any Shari’ah principles and concepts authorised by the SC’s Shari’ah Advisory Council (SAC) are Islamic securities. The Shari’ah concepts and principles accepted for the structuring, reporting and trading of Islamic securities are:

i. Musyarakah (Profit and Loss-sharing)

This is a joint agreement involving two or more parties to support a business venture, in which all participants may provide capital in the form of cash or in-kind to support the business venture. Any benefit generated from the venture will be allocated based on a pre-agreed profit-sharing arrangement, but on equity participation, a loss will be shared.

ii. Mudharabah (Profit-sharing)

Mudharabah is a particular type of partnership in which one individual gives money to another for investment in a business enterprise. The parties are a rabb al-mal or investor who supplies the money alone; and a mudharib or developer who handles the project independently. If the company is successful, the benefit will be divided on the basis of a calculation agreed in advance. In case of a business interruption, the loss shall be borne entirely by the capital provider.

iii. Ijarah (Leasing)

This is a *manfaah* (usufruct) type of contract where a lessor (owner) rents an asset or facilities to his client at the *aqad* (company) at a negotiated rental fee and a fixed rental duration. Ownership of the leased equipment is still in the lessor's hands.

iv. Bai ' Bithaman Ajil or BBA (Deferred-payment Sale)

This contract refers to the delayed and instalment-based selling and acquisition agreement for the financing of an item, with a pre-agreed payment period. The selling price will include a margin for profit.

v. Istisna ' (Purchase Order)

This is an asset purchase deal, where a customer places an order to buy the product that will be shipped in the future. In other words, the consumer will authorize a vendor or manufacturer to manufacture or build the product that will be constructed in the future, in compliance with the sale and purchase contract specifications. The sale and purchase rates will be determined by both parties in the contract if they desire, and payment may be postponed or negotiated on the basis of the finished schedule of works.

vi. Murabahah (Cost-plus Sale)

This contract is similar to the sale and purchase transaction for the financing of an asset where the expense and profit margin (mark-up) is negotiated and settled upon by all involved parties. The purchase price payment can be either on a fixed lump - sum basis or on an instalment basis, which will be stated in the arrangement.

2.0 LITERATURE REVIEW

2.1 Growth and Development of Sukuk

The global Sukuk market finished the year with positive growth resulting in higher commodity prices and continued rise in some jurisdictions in sovereign Sukuk issuances, stable corporate Sukuk issuances, and strong Sukuk problem pipeline for 2019. Sukuk managed to receive attention from new issuers as well as a growing base of investors which is a promising trend (IIFM Sukuk Report, 2019). In 2018, total global issuance amounted at USD 123.15 billion. The accumulated Sukuk issuances from January 2001 until December 2018 are shown in Table 1.

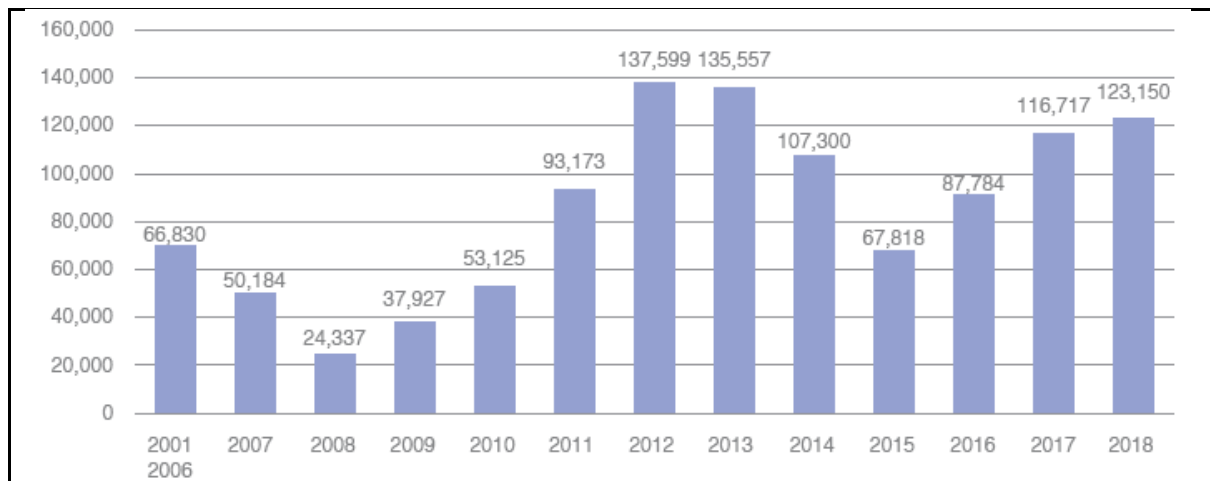

Fig. 2. Total Global Sukuk Issuances (Jan 2001 - Dec 2018) (USD Million)

Note: Total Global Sukuk Issuance USD 1,101,502 Million

Source: IIFM Sukuk Report

Figure 1 shows a small increase in global Sukuk issuance from USD 116.7 billion in 2017 to USD 123.15 billion in 2018 by five per cent. The steady amount of issuance during 2018 was mainly due to sovereign Sukuk issuances from Asia, G.C.C., Africa and some jurisdictions. Malaysia came to lead the Sukuk market by growing the share of countries such as Indonesia, the UAE, Saudi Arabia and even, to some extent, Turkey. In 2018, overall global Sukuk issuances amounted to USD 32.98 billion, resulting in a decrease of USD 4.66 billion or 14 per cent from the 2017 average of USD 37.64 billion. 2017 was the best year in which the most massive volume of international Sukuk issuance has been registered since the Sukuk market was introduced (IIFM Research, 2019).

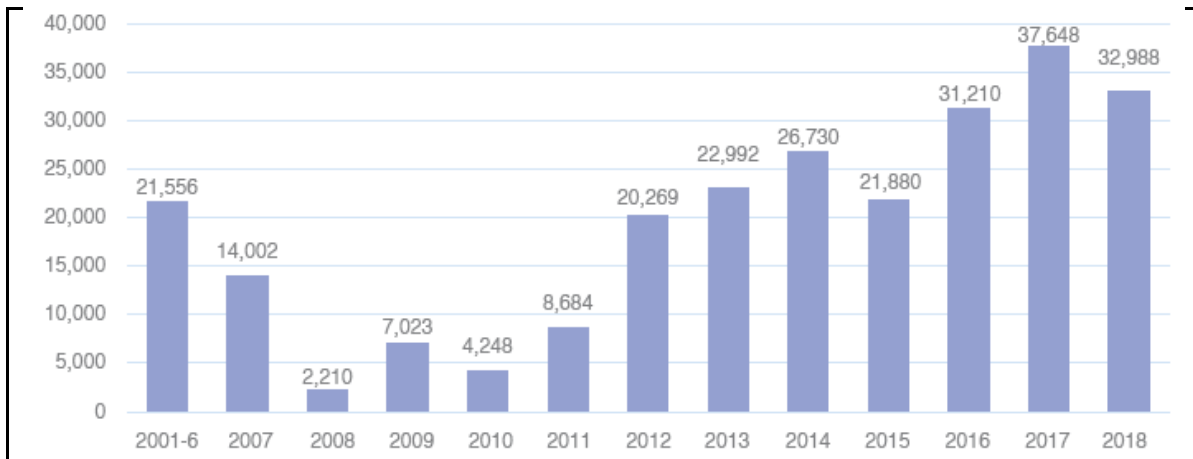

Fig. 3. Total International Sukuk Issuances (Jan 2001 - Dec 2018) (USD Million)

Note: Total International Sukuk Issuance USD 251,440 Million

Source: IIFM Sukuk Report

Figure 4 shows that domestic Sukuk issuances have risen from USD 79.06 billion in 2017 to USD 90.16 billion or positive 14 per cent. The most extensive distribution of this increase comes from Malaysia's USD 48.6 billion market share, led by Saudi Arabia's USD 14.2 billion, Indonesia's USD 13.5 billion and Turkey's USD 6.8 billion.

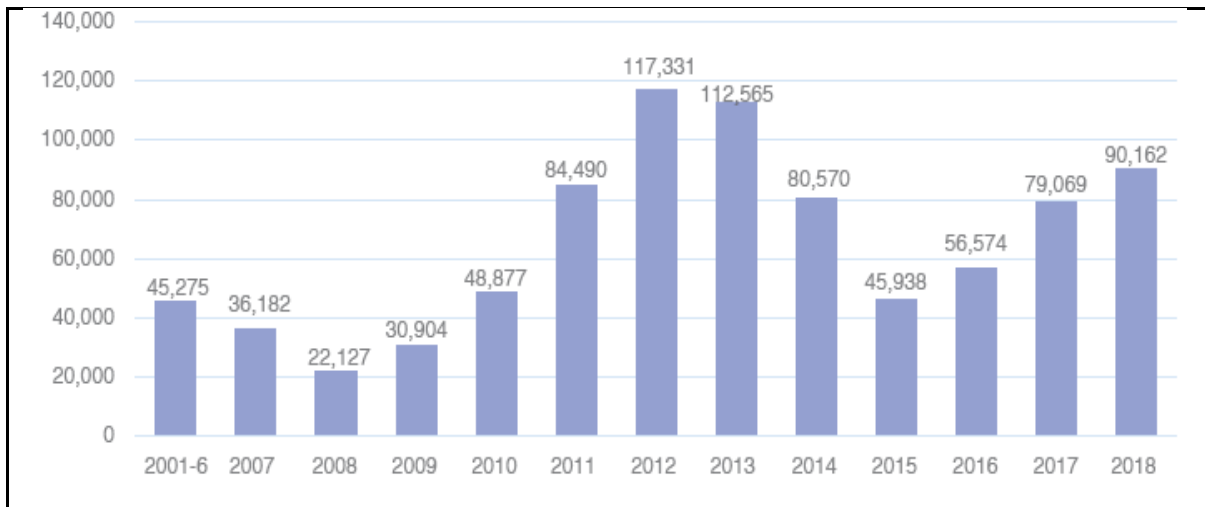

Fig. 4. Total Domestic Sukuk Issuances (Jan 2001 - Dec 2018) (USD Million)

Note: Total Domestic Sukuk Issuance USD 850,062 Million

Source: IIFM Sukuk Report

Table 1 shows that the US has held its volume and value leader in the global market for Sukuk with 28.26%, closely followed by Malaysia with 25.32%. In comparison, the share of Saudi Arabia has gradually increased by 18.82%, Indonesia by 6.6%, Bahrain by 4.55% and Turkey by 3.88%. Since its establishment, the five GCC countries, together with Saudi Arabia, Qatar, Oman, and Bahrain, have commanded over 59.34 per cent of all international Sukuk issuances. Table 1 shows that these countries accounted for around 59.20 per cent of global problems. Malaysia also has a formidable presence on the international market occupying about 27.83 per cent followed by Saudi Arabia and the UAE with 25.34 per cent and 25.04 per cent of all international issuances respectively. At the same time, Indonesia continues to improve its 9.40 per cent share (IIFM Sukuk Report, 2019).

Table 1. Regional Break-up of International Issuances (Jan 2001 - Dec 2018).

ASIA & FAR EAST	Number of Issues	Amount (USD Million)	% of Total Value
China	1	97	0.04%
Hong Kong	5	3,196	1.27%
Indonesia	18	16,603	6.60%
Japan	3	190	0.08%
Malaysia	107	63,653	25.32%
Pakistan	4	3,600	1.43%
Singapore	4	711	0.28%
Total	142	88,050	35.02%
GCC & MIDDLE EAST	Number of Issues	Amount (USD Million)	% of Total Value
Bahrain	102	11,430	4.55%
Kuwait	17	3,327	1.32%
Oman	5	4,219	1.68%
Qatar	18	11,845	4.71%
Saudi Arabia	59	47,324	18.82%
United Arab Emirates	109	71,054	28.26%
Total	310	149,199	59.34%
AFRICA	Number of Issues	Amount (USD Million)	% of Total Value
Nigeria	1	150	0.06%
South Africa	1	500	0.20%
Sudan	1	130	0.05%
Total	3	780	0.31%
EUROPE & OTHERS	Number of Issues	Amount (USD Million)	% of Total Value
France	1	1	0.00%
Germany	3	206	0.08%
Luxembourg	3	280	0.11%
Turkey	24	9,762	3.88%
United Kingdom	10	1,719	0.68%
USA	5	1,367	0.54%
Kazakhstan	1	77	0.03%
Total	47	13,411	5.33%
Grand Total	502	251,441	100%

Source: IIFM Sukuk Report

2.2 Comparisons between Sukuk and Bonds

There are at least five variations and four parallels between Sukuk and bonds, according to the Capital Market Centre Wealth Management Company (2012). The first distinction is that Sukuk signifies ownership of a specific asset while bonds signify debt commitment. The relationship between the issuer and the bond buyer is like a loan-provider and loan-receiver. The interest rate for the loan is set, which results in a riba. Second, from the Shari'ah perspective, the asset subject to Sukuk securities must be allowed. Regarding bonds, however, the securities will also be backed up by funds which Islam does not accept. Thirdly, the validity of bonds depends on the reputation of the issuer and is therefore determined, while the validity of Sukuk does not rely on the issuer but on the value of the asset that supports the Sukuk. Fourthly, the selling of Sukuk in secondary markets is considered to be the selling of an asset's ownership, but the sale of bonds is also debt sales. The fifth distinction is that Sukuk offers the possibility to increase the original asset and thus, the value of Sukuk itself. In contrast, the actual debt in bonds cannot be increased. Given these five differences, the Sukuk and bonds have many parallels. Both can be liquidated in secondary markets, rating institutions achieve their credit rankings, and both can increase credit and design and provide variety.

Table 2. The main differences between Sukuk and conventional bonds.

Difference	Sukuk	Conventional Bond
1. Ownership	Holder ownership well defined	Holder owns cash flow only from the pure debt
2. A contract between holders and issuers	Based on a lease or a defined business.	Purely earning money on money.
3. Nature and use of the underlying	The underlying assets, business or project must be Islamic permissible in both nature and use.	Bonds can be issued to finance almost any purpose (not necessarily assets) that is legal in its jurisdiction.
4. Sale operation	Sale of a share of assets, business activity or project	Sale of a debt.
5. Asset - related expenses	Asset-related expenses may attach to Sukuk holders.	Bondholders are not concerned with asset-related expenses
6. Security prices	Sukuk prices depend on the market value of the underlying asset.	Bond prices depend only on the creditworthiness of the issuer.
7. Risk and return	There is an explicit sharing of risk and profit by the financier and the borrower. Sukuk holders earn returns from the profit generated through the asset.	Bondholders assume the low risk and earn returns related to interest charged out of the loan contract.
8. Tradability of the instrument	Depends on the nature of the underlying asset (i.e. Istisna and Slam Sukuk are non-tradable but Ijara and Musharakah Sukuk are tradable)	No restriction.
9. Shari'ah compliance	Investment in Shari'ah-compliant activities.	Investment in any business without restriction.
10. Standardization	Lack of standardization	Standardized instruments.

Source: Mseddi and Naifar (2013)

2.3 Capital Market Theory

The capital market theory suggests that a security risk is fundamental to its expected return. The present value of its expected future cash flows as indicated in the cost of the security comprising many elements such as volatility, liquidity, and risk of bankruptcy. The irregularity of new information, which is expected, contributes to the assumption that changes in prices and is are random and unpredictable even though costs are reasonably based. Dyckman and Morse (1986) describe the perfect capital market as efficient markets where the prices of the securities sold in the market fully reflect all available information at present, and these prices react instantaneously in an unbiased manner to new information.

Such a definition includes terms such as vague, indeterminable definition namely 'fully reflect', 'available information', and 'unbiased fashion'. One way to resolve the uncertainty is to associate the real market price behaviour to the way that prices will be changed. The capital market theory was formed based on several assumptions. It includes that all investors are Markowitz efficient investors who prefer investments by expected return and risk. The perfect competition explains that all economic agents act in a manner where they have no market power over prices. Investors may borrow or lend any value at a risk-free rate of interest. All investors have similar expectations for returns. All investments are infinitely divisible. Lastly, transaction cost or tax does not exist, there is no inflation or any change in interest rate, and capital markets are in equilibrium.

2.4 Volatility of Sukuk Markets

Several studies examine volatility behaviour of Sukuk markets such as Rahman and Omar (2012), Rusgianto and Ahmad (2013), Rahman, Omar, and Kassim (2013), Hafezian et al. (2015), Paltrinieri et al. (2015), Maghyreh and Awartani (2016), Naifar (2016), Sclip et al. (2016), and Naifar et al. (2016). Previous studies mostly employ the GARCH model to measure volatility. In these studies, the high value of the sum of GARCH estimates implies the presence of volatility persistence, where the expected future volatility takes longer to decay to the unconditional variance. This suggests that any shocks will affect the spreads of the Malaysian Sukuk and it will take some time before the spreads gradually return to equilibrium (Yap and Gannon, 2007; Rahman, Omar, and Kassim, 2013). Besides, Rahman and Omar (2012) mention that the small size of crisis coefficient for the volatility of AA3 Sukuk spreads (0.0001) indicates that the presence of the crisis gives almost no impact to the volatility of Sukuk spread. Rusgianto and Ahmad (2013) examine the volatility behaviour of the Sukuk market under the consideration of structural breaks for Dow Jones Citigroup Sukuk Index (2007-2011) by using the EGARCH model. The main finding indicates that structural breaks significantly alter the volatility behaviour of Sukuk. It indicates that the volatility during pre-crisis and contemporaneous periods is more sensitive to market events compared to the post-crisis period.

Rahman, Omar, and Kassim (2013) explore the data for Sukuk spreads are computed from the YTM and government yields from the database of BPAM using GARCH model. They examine how the volatility of Sukuk spreads can be influenced by the presence of the 2007/2008 global financial crisis and stock market volatility

(Rahman, Omar, and Kassim, 2013). Although the ARCH term is significant, the size of the coefficient was much smaller, indicating that the volatility of spread was less affected by the past shock or news. By referring to the short-term Sukuk spreads of the A3 and BBB3, the GARCH term of higher lags (up to lag 2) appeared to be significant, indicating the persistence in volatility for longer trading days.

Hafezian et al. (2015) estimate the value-at-risk for Sukuk market using GARCH models on three Sukuk issued by Malaysia, UAE and the Islamic Development Bank (IDB). Sukuk return series recorded in residuals the characteristics of conventional returns of bonds such as volatility clustering, leptokurtosis, heteroscedasticity and autocorrelation. They find that the asymmetric GARCH model produces better results compared to other models. Besides, Aloui, Hammoudeh and Hamida (2015) assess the co-movement between the Shari'ah-compliant stocks and Sukuk in the Gulf Cooperation Council (GCC) countries. They use the daily data for the NASDAQ Dubai GCC, Sukuk Index (GSKI), Dubai GCC, Corporate Sukuk Index (GSKC) and the Dubai GCC, Financial Services Sukuk Index (GSKF). The empirical evidence indicates a strong dependence between these *Shari'ah* stock and Sukuk indices. The degree of co-movement power is varying over time and frequency, and the long-run is dominant. Paltrinieri et al. (2015) suggest that Sukuk present diversification opportunities, a significant volatility-adjusted performance, and lower correlations, especially during the financial crisis. However, Balcilar et al. (2015) show Sukuk are not immune from shock and volatility spillovers from conventional global markets using the Markov regime-switching GARCH model with dynamic conditional correlations (MS-DCC GARCH) model. Volatility in global debt and equity markets indicate the opposite spillover effects on Islamic bonds. They find positive spillover effects from global equities on Islamic bonds while a negative volatility spillover is perceived from global bonds into Islamic bonds (Sukuk).

Maghyreh and Awartani (2016) suggest that Sukuk are a net receiver of returns and volatility information from other equity and bond markets. Regarding volatility, the bond market is a net giver of information to other markets. Naifar (2016) investigates the dependence structure for Sukuk yields and stock markets (returns and volatility) in the case of Saudi Arabia. The first dataset consists of daily yield to maturity data of Sukuk from Thomson Reuters's database from 23 November 2010 to 06 October 2014. Asymmetric dependence between Sukuk and stock market volatility have found, and this finding suggests that Sukuk yields and stock market volatility link with the same intensity and the linkage are immune to extreme events. On the other study, Naifar et al. (2016) also used GARCH models for the three equally-weighted Sukuk indices for each of the three largest Sukuk markets (UAE, Saudi Arabia, and Malaysia). The first dataset employed in this study consists of the Dow Jones Sukuk Index (DJSI) over the period from January 2010 to December 2014. The second dataset consists of the Malaysian Sukuk index, which is the dominant player in the world Sukuk market. They show the dependence between the historical stock return volatility and the local Sukuk yields was small in the case of UAE and Malaysia compared to the relationship between the local Sukuk yields and the global stock market volatility. The local Sukuk yields are more sensitive to their local stock market volatility than to that of the global and local equity markets.

Sclip et al. (2016) use daily returns data for 68 most liquid Sukuk listed in the major Islamic bond markets, such as Bursa Malaysia, NASDAQ Dubai, and London Stock Exchange using GARCH-family models. The sample period is from 01 January 2010, to 31 December 2014. They suggest a moderate reaction to market shocks and greater persistence in conditional volatility. There was no leverage effect in the Sukuk market. The volatility behaviour of Sukuk index is similar to the other three global stock indices. Their findings imply that volatility linkages between Sukuk and regional market indices are stronger during turmoil periods. Adekunle and Masih (2017) mention that volatility in global debt and equity markets have opposite spillover effects on Sukuk. They find positive spillover effects from global equities on Sukuk while a negative volatility spillover is observed from global bonds into Islamic bonds. While the finding of positive spillover effects from global stock markets is consistent with the presence of common market uncertainties driving risk globally. The negative spillover effect observed from global bonds suggests that good and bad news in global debt markets have an opposite impact on the return dynamics in Sukuk. Previous studies mostly employ GARCH-family models to measure volatility on Sukuk or stock indices. The previous studies indicate the high value of the sum of GARCH estimates implies the presence of volatility persistence, where the expected future volatility takes longer to decay to the unconditional variance. There is a phenomenon of volatility clustering and also leverage effects. In this study, if the results of the risk premium are positive and significant, support the positive relationship between risk and returns. The higher the risk, the higher the returns.

3. DATA COLLECTION AND METHODOLOGY

The daily data of historical prices from the years 2005 to 2015 are collected from the Bloomberg database (Saturdays and Sundays excluded). The Dow Jones Sukuk Index (DJSI) is used in this study because it is designed

to assess the performance of Sukuk in the global market. In this study, daily returns (r_t) are calculated as the continuously compounded returns, which are the first difference in the logarithm of closing prices of Sukuk index:

$$r_t = \log \left(\frac{P_t}{P_{t-1}} \right)$$

Where P_t and P_{t-1} are the closing prices of the DJSI on the current day (P_t) and the previous day (P_{t-1}), respectively. The Sukuk index included in the sample have different launching dates and a different number of daily observations, as shown in Table 3. The long-time series data collection enables the researcher to measure volatility behaviour of Sukuk index.

Table 3. Dow Jones Sukuk Index

List of Sukuk Index	Launch Date	N
Dow Jones Sukuk Index	28 April 2006	2,424

Source: Bloomberg Database (2015)

The Sukuk indices are created with specific objectives. The first objective involves introducing investors about Sukuk and enlightening market transparency. The second objective is to detail the conditions of the benchmark to enable comparison between the performances of a Sukuk issue as compared to a Sukuk index. Benchmarks provide a measure of the underlying market that allows comparisons to be made. The last primary objective for the Sukuk index is to serve as a basis for investable and tradable products in the marketplace. A brief explanation of each index used in this study is presented next.

3.1 Dow Jones Sukuk Index (DJSI)

The Dow Jones Sukuk Index (DJSI) assesses the performance of Sukuk in the global market. Originated in October 2005, it proposes a benchmark for investors who seek exposure to *Shari'ah*-compliant fixed income, investments, and any eligible asset. The bonds must pass the screening for *Shari'ah* compliance and the index fulfils the standards issued by the AAOIFI. The DJSI must have a minimum maturity of one year, a minimum size, prominent of USD 200 million, and a particular or total rating of at least BBB-/Baa3 by heading rating agencies (Bloomberg, 2018).

3.2 Method: Measuring the Volatility of Sukuk Index (DJSI)

The objective of this study is to measure the volatility in the presence of structural breaks, namely the 2008 global financial crisis for the DJSI. The researcher employs ARCH, GARCH, EGARCH, TGARCH, and PGARCH models to examine the volatility behaviour of the indices.

3.2.1 ARCH (1) Model

The ARCH Model stands for *autoregressive conditional heteroscedasticity*. Heteroscedasticity means non-constant volatility that was first established by Engle (1982). It suggests that the variance of the residuals at time t depends on the squared error terms from past periods. Engle simply suggested that it is better to simultaneously model the mean and the variance of a series when suspect the conditional variance is not constant. In a standard linear regression:

$$y_i = \alpha + \beta x_i + \epsilon_i$$

where the variance of the residuals, ϵ_i , is constant and termed as homoscedastic, and uses ordinary least squares to estimate α and β . If the variance of the residuals is not stable, it is termed as heteroscedastic, and weighted least squares should be applied to estimate the regression coefficients. Hetero (different or unequal) is the opposite of homo (same or equal). Skedastic means spread or scatter. Heteroscedasticity is an unequal spread. In this study, the return on Sukuk is:

$$r_t = \mu + \sigma_t \epsilon_t$$

where r_t is the residual return on time t . ϵ_t is a sequence of $N(0,1)$ independent, identically distributed (i.i.d.) random variables. In this research, the returns of Sukuk are conditionally normal (conditional on all information up to time $t-1$, the one-period returns are normally distributed).

$\sigma_t^2 = \alpha_0 + \alpha_1 \alpha_{t-1}^2$ where $\alpha_0 > 0$ and $\alpha_1 \geq 0$ to ensure positive variance and $\alpha_1 < 1$ for stationary. Under an ARCH(1) model, if the residual return, α_t is large in magnitude, the forecast for the next period's conditional volatility, σ_{t+1} will be large. Engle's idea starts from the fact that he allows the variance of the residuals (σ^2) to depend on history, or to have heteroscedasticity because the variance will change over time. This study defines the conditional forecast error or the difference between the squared residual return and conditional expectation of the squared residual return as:

$$\begin{aligned} v_t &= \alpha_t^2 - E[\alpha_t^2 | I_{t-1}] \\ &= \alpha_t^2 - \sigma_t^2 \end{aligned}$$

where I_{t-1} is the information at time $t-1$. Note that v_t is a zero mean, uncorrelated series. The ARCH(1) equation becomes:

$$\begin{aligned}\sigma_t^2 &= \alpha_0 + \alpha_1 \alpha_{t-1}^2 \\ \alpha_t^2 - v_t &= \alpha_0 + \alpha_1 \alpha_{t-1}^2 \\ \alpha_t^2 &= \alpha_0 + \alpha_1 \alpha_{t-1}^2 + v_t\end{aligned}$$

which is an AR(1) process on squared residuals.

3.2.2 GARCH (1,1) Model

Engle (1995) looked more like a moving average specification than an autoregression. From this, a new idea was born to include the lagged conditional variance terms as autoregressive terms. Bollers lev (1986) published a paper titled 'Generalised Autoregressive Conditional Heteroscedasticity' starting a new family of GARCH models. His study presents the GARCH model that was developed by Engle (1982), Bollers lev (1986), Nelson (1991) and others to model time-varying volatility. The GARCH (1,1) model is defined as:

$$\begin{aligned}y_t &= \mu + \varepsilon_t \\ \varepsilon_t &= \eta_t h_t^{1/2}, \eta_t \sim N(0,1) \\ h_t &= \omega + \alpha(L)\varepsilon_t^2 + \beta(L)h_t\end{aligned}$$

Where μ is the mean of the process, h_t is the conditional variance of y_t , $\alpha(L) = \alpha_1 L + \dots + \alpha_m L^m$, $\beta(L) = \beta_1 L + \dots + \beta_p L^p$ and L denotes the lag operator. The GARCH process is covariance stationary if the following restriction is satisfied:

$$\alpha(1) + \beta(1) < 1$$

The conditions $\omega \geq 0$, $\alpha_i \geq 0$ for $i = 1, \dots, m$, and $\beta_j \geq 0$ for $j = 1, \dots, p$ is assumed, in Bollers lev (1986), to ensure that the conditional variance h_t is positive. By rearranging the terms in the equation of the conditional variance, it follows that:

$$[1 - \alpha(L) - \beta(L)]\varepsilon_t^2 = \omega + [1 - \beta(1)]v_t$$

Which is the so-called "ARMA in squares" representation of the GARCH equation, where $v_t = (\varepsilon_t^2 - h_t)$. All the roots of $[1 - \alpha(L) - \beta(L)]$ and $[1 - \beta(L)]$ are assumed to lie outside the unit circle. However, many empirical applications of the GARCH (p,m) model for volatility indicate the existence of unit root in the estimated lag polynomial $[1 - \hat{\alpha}(L) - \hat{\beta}(L)]$.

3.2.3 EGARCH (1,1) Model (Exponential GARCH)

This model captures asymmetric responses of the time-varying variance to shocks and at the same time, ensures that the variance is always positive. It was developed by Nelson (1991) with the following specification:

$$n(\sigma_t^2) = \omega + \beta_1 \ln(\sigma_{t-1}^2) + \alpha_1 \left\{ \frac{|\varepsilon_{t-1}|}{\sigma_{t-1}} - \sqrt{\frac{2}{\pi}} \right\} - \gamma \frac{\varepsilon_{t-1}}{\sigma_{t-1}}$$

where γ is the asymmetric response parameter or leverage parameter. The sign of γ is expected to be positive in most empirical cases so that a negative shock increases future volatility or uncertainty. In contrast, a positive shock eases the effect on future uncertainty which is a contrast to the standard GARCH model where shocks of the same magnitude, positive or negative, has the same impact on future volatility.

In macroeconomics, financial markets and corporate finance, a negative shock usually implies bad news, leading to a more uncertain future. Consequently, shareholders would require a higher expected return to compensate for bearing increased risk in their investment (Wang, 2003). Higher-order EGARCH models can be specified similarly; EGARCH (p,q) is as follows:

$$\ln(\sigma_t^2) = \omega + \sum_{j=1}^p \beta_j \ln(\sigma_{t-j}^2) + \sum_{i=1}^q \alpha_i \left\{ \frac{|\varepsilon_{t-i}|}{\sigma_{t-i}} - \sqrt{\frac{2}{\pi}} \right\} - \gamma_i \frac{\varepsilon_{t-i}}{\sigma_{t-i}}$$

3.2.4 TGARCH (1,1) Model (Threshold GARCH)

Another volatility model commonly used to handle leverage effects is the threshold GARCH (TGARCH) model (Ahmed & Suliman, 2011). In the TGARCH(1,1) version of the model, the specification of the conditional variance is:

$$\sigma_t^2 = \omega + \alpha_1 \varepsilon_{t-1}^2 + \gamma d_{t-1} \varepsilon_{t-1}^2 + \beta_1 \sigma_{t-1}^2$$

where d_{t-1} is a dummy variable that represents:

$$\begin{aligned}d_{t-1} &= 1, \text{ if } \varepsilon_{t-1} < 0, && \text{bad news} \\ &= 0, \text{ if } \varepsilon_{t-1} \geq 0, && \text{good news}\end{aligned}$$

The coefficient γ is known as the asymmetry or leverage term. When $\gamma = 0$, the model collapses to the standard GARCH forms. Otherwise, when the shock is positive (good news), the effect of volatility is α_1 , but when the news is negative (bad news), the effect of volatility is $\alpha_1 + \gamma$. Hence, if γ is significant and positive, adverse shocks have a more massive effect on σ_t^2 than positive shocks.

In the general specification of this model, TGARCH (p,q), the conditional variance equation is specified as follows:

$$\sigma_t^2 = \omega + \sum_{i=1}^q (\alpha_i + \gamma_i d_{t-i}) \varepsilon_{t-1}^2 + \sum_{j=1}^p \beta_j \sigma_{t-1}^2$$

α_i, γ_i and β_j are non-negative parameters satisfying conditions similar to those of the GARCH model.

3.2.5 PGARCH (1,1) Model (Power GARCH)

Ding, Granger, and Eagle (1993) also introduced the Power GARCH (PGARCH) specification to deal with asymmetry. In Power GARCH, an optional parameter γ can be added to account for asymmetry in modelling up to order r . The model also allows one to estimate the power parameter δ instead of imposing it on the model. The general asymmetric Power GARCH model specifies σ_t as of the following form:

$$\sigma_t^\delta = \omega + \sum_{j=1}^q \beta_j \sigma_{t-1}^\delta + \sum_{i=1}^p \alpha_i (|\varepsilon_{t-i}| - \gamma_i \varepsilon_{t-1})^\delta$$

Where α_i and β_j are the standard ARCH and GARCH parameters, γ_i , are the leverage parameters, and δ is the parameter for the power term, and:

$$\delta > 0, |\gamma_i| \leq 1$$

For $i = 1, 2, \dots, r, \gamma_i = 0$ for all $i < r$ and $r \leq p$.

The symmetric model sets $\gamma_i = 0$ for all i . When $\delta=2$, the above equation becomes a classic GARCH model that allows for leverage effects and when $\delta=1$ the conditional standard deviation will be estimated. Also, the study can increase the flexibility of the PGARCH model by considering δ as another coefficient that must also be estimated (Zivot, 2008).

3.0 RESULTS AND DISCUSSION

Table 4 shows the descriptive statistic.

Table 4. Descriptive statistic

Descriptive Statistics for Daily Market Returns of the DJSI										
Variables	Mean	Median	Max	Min	Std. Dev	Skewness	Kurtosis	Jacque Berra	Probability	Observation
DJSI (30/9/2005-12/5/2015)	0.0000	0.0000	0.1449	-0.0783	0.0043	10.0296	539.4598	34,691,048	0.0000	2,424

Source: Authors' calculation

The Dow Jones Sukuk Index (DJSI) will be estimated using daily data consisting of 2,424 observations. Figure 5 illustrates the closing price, return, and residual of DJSI.

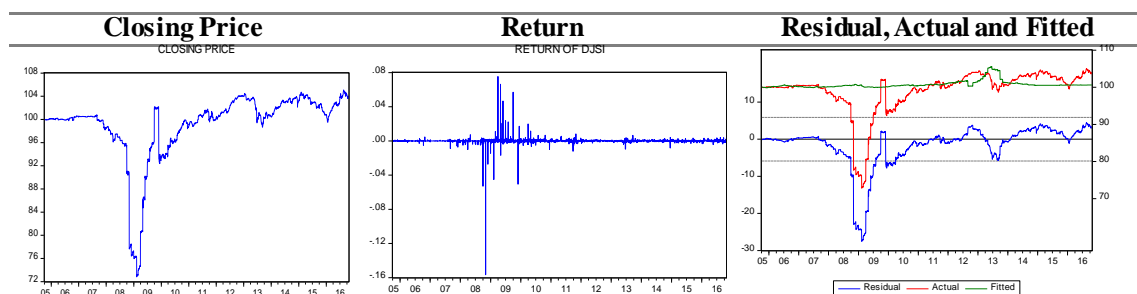

Fig. 5. Closing Price, Return and Residual of DJSI

Figure 5 examines the existence and nature of volatility clustering phenomenon in DJSI. Time series of financial asset returns often exhibit volatility clustering property, which explains the tendency of significant changes in prices to cluster together, resulting in persistence amplitudes of price changes (Emenike, 2010). The period of high volatility is followed by a period of high volatility for prolonged periods while the period of low volatility is

followed by a period of low volatility for its extended period. Volatility clustering makes investors more averse to uncertainty. Investors, in turn, demand a higher risk premium to insure against the increased uncertainty. A higher risk premium results in a higher capital cost, which leads to less private physical investment. (Mandelbrot, 1963; Fama, 1965 & Black, 1976).

High volatility is indicated in the graph of DJSI return between 2007 until 2009, with the inclusion of the 2008 global financial crisis. Various studies on volatility clustering suggest that adverse shocks to index prices will generate more volatility compared to positive shocks of equal magnitude (Niyitegeka & Tewari, 2013). Statistically, volatility clustering requires high autocorrelation in square returns, technically termed as the ARCH effect. Table 5 summarises the results of the GARCH, EGARCH, TGARCH and PGARCH models for Dow Jones Sukuk Index (DJSI).

Table 5. Results of GARCH Models for DJSI.

Parameters (2005-2016)	GARCH (1,1)	EGARCH (1,1)	TGARCH (1,1)	PGARCH (1,1)
Mean Equation				
\emptyset (Constant)	0.0000	0.0000	0.0000	0.0000
Variance Equation				
ω (Constant)	-0.0000***	-10.8918***	-0.0000***	-0.0000
α (ARCH effect)	0.1056***	0.0100	0.1407***	0.0044
β (GARCH effect)	0.0275***	0.0100	-0.0052	-0.9688
γ (Leverage effect)	-	0.0100	-0.1436***	0.0000
$\alpha + \beta$	0.1331	0.0200	0.1355	-0.9644
Log Likelihood	11,683.20	11,638.26	11,693.58	11,693.66
Akaike info criterion	-8.0853	-8.0535	-8.0918	-8.0911
Schwarz criterion	-8.0770	-8.0432	-8.0815	-8.0788
ARCH-LM Test for heteroscedasticity up to 5 lags				
F-statistic	0.0029	0.0184	0.0044	0.0048
Probability	1.0000	0.9999	1.0000	1.0000

Note: ***, ** and * represents significant at the 1%, 5% and 10% level, respectively.

*The best GARCH model is the GARCH(1,1) model. Both α and β are significant.

Source: Author's estimation.

The best GARCH performance depends on the maximum value of log-likelihood (LL) and the minimum amounts of AIC and SC. Hence, the best model for DJSI is the GARCH (1,1) model because of both α and β are significant. Although the TGARCH model is the best based on the reported values of AIC and SC, as shown in Table 5, the TGARCH model shows β is not significant. Figure 5 indicates high volatility during the 2008 global financial crisis. The GARCH (1,1) model contains one ARCH effect and one GARCH effect. The ARCH parameter corresponds to α (short-run persistence of shocks), and the GARCH parameters are β (long-run persistence of shocks). The sum of ARCH and GARCH coefficients ($\alpha + \beta$) that is close to one indicates persistent volatility shocks. This effect is usually noted in high-frequency financial data. As suggested by Engle and Bollerslev (1986), if $\alpha + \beta = 1$, a current shock persists indefinitely in conditioning the future variance. A value more significant than the unity of $\alpha + \beta$ implies increasing volatility with time, while an amount less than unity signifies decaying shocks over time (Chou, 1988).

The result shows that $w > 0$, $\alpha, \beta \geq 0$ and $\alpha + \beta < 1$. First, constant $w > 0$ means that volatility cannot have a zero or negative mean. This is an exception of the EGARCH model that shows a negative result for omega, $w < 0$, -10.8918, considering the EGARCH has no constraint on the omega ($w > 0$) as in other GARCH models because the long-term variance will be in exponential form. This GARCH model, however, assumes that feature volatility is only determined by the magnitude and not the positivity or negativity of unanticipated excess returns. The EGARCH allows good news and bad news to have a different impact on volatility, a privilege not provided by the standard GARCH. The EGARCH model allows big news to have a greater impact on volatility than GARCH model. EGARCH would have higher variances in both directions because the exponential curve eventually dominates the quadrature (Bollerslev, Engle, & Nelson, 1994; Nelson, 1991; Jacquier, Polson & Rossi, 2004).

The parameters for the intercept (w), shock (α) and asymmetry (γ) are 'unrestricted'. In contrast, the parameter on the lagged variance (β) is constrained (for stationarity) to be less than one and positive. Second, the positive parameters α, β show that the conditional variance forecasts will increase if there is a significant variation in returns. Hence, the model captures the modern feature of volatility clustering. Finally, $\alpha + \beta < 1$ indicates the persistence of shocks to volatility will eventually fade away, which depicts another stylised characteristic of volatility and mean-reversion.

Based on Table 5, the ARCH and GARCH effect is positive and significant at the 0.01 level. The sum of ARCH and GARCH coefficients is lower than one, implying a low level of persistence in volatility. The asymmetric tem

(leverage effect) in the EGARCH model is not significant, suggesting no leverage effect. Similarly, the PGARCH results also show no leverage effect. Hence, positive and negative shocks for previous periods do not have a different impact on the volatility. Only TGARCH (1,1) captured by γ is negative (-0.1436) and significant at the 0.01 level, supporting the presence of leverage effect. To conclude, DJSI demonstrates a low level of persistence in volatility, and there is no leverage effect based on the best GARCH model.

4.0 CONCLUSION

Sukuk has become one of the most important financial instruments in the Islamic capital market. Therefore, understanding Sukuk market behaviour is of utmost importance to provide a robust and competitive environment for the industry. One aspect of Sukuk market behaviour is volatility. In finance, volatility is a measure of the variation of price of a financial instrument over time. If you can predict the price, you have less risk in the transaction. However, if volatility is high, the predictability is low. Table 6 shows the best GARCH model is GARCH (1,1) model, low persistence, and there are leverage effect and volatility clustering.

Table 6. Summary of Results for Volatility Behaviour

Sukuk Indices (2005-2015)	The Best GARCH Model				Persistence ($\alpha + \beta$)	γ	Volatility Clustering
	GARCH	EGARCH	TGARCH	PGARCH			
DJSI	/***				Low	/	/

*Note: The best GARCH model is selected based on LL, SC and AIC information criteria.

Leverage effect (γ) = asymmetric term (significant results show the presence of a leverage effect).

*Persistence ($\alpha + \beta$) records based on the best GARCH model. Low persistence: $\alpha + \beta < 1$.

Source: Authors' calculation.

The analyses are conducted in three separate periods: pre, during, and post-2008 global financial crisis subject to data availability—the Dow Jones global market display low volatility behaviour with the presence of leverage effects. The empirical contributions in this study will encourage investors to invest in Sukuk to increase economic growth and investment. There is evidence to support that the Sukuk index exhibit the existence of volatility persistence, volatility clustering, and leverage effect based on GARCH model estimations. The volatility of Sukuk index is low, indicating the low-risk level in the Sukuk market. It is different from the equity market, which shows higher volatility and higher risk than Sukuk, although Sukuk and equity have similar characteristics (Modirzadehbami & Mansourfar, 2011). The understanding of market volatility components such as the speed of adjustment (mean reversion) in the case of any shocks in the Sukuk market requires extra attention from portfolio managers, policymakers, and other market participants. In conclusion, this analysis provides valuable information and guidelines to the issuers, policymakers, regulatory bodies, and investors, both Muslim and non-Muslim, and it can arouse their interest in Islamic bonds.

REFERENCES

- Abdel-Khaleq, A. & C. Richardson. 2007. "New Horizons for Islamic Securities: Emerging Trends in Sukuk Offerings". Chicago Journal of International Law. Vol. 2. (7).
- Ahmad, W., & R. M. Radzi. 2011. "Sustainability of Sukuk and Conventional Bond during Financial Crisis: Malaysia's Capital Market". Global Economy and Finance Journal. p. 33-45.
- Ahmed E. M. A. & S. Z. Suliman. 2011. "Modeling Stock Market Volatility Using GARCH Models Evidence from Sudan". International Journal of Business and Social Science. Vol. 2. (23).
- Ab Hamid, N.H., NB. Zakaria, & N.H. Ab Aziz. 2014. "Firm's Performance and Risk with the Presence of Sukuk Rating as Default Risk". Procedia Social and Behavioural Sciences. p. 181-188.
- Bank Islam Malaysia Berhad. 2012. "Sukuk: Shari'ah Guidelines for Islamic Bonds". Islamic Banking Operations and Regulatory Framework Workshop. Centre for Banking Studies. Central Bank of Sri Lanka.
- Black, F. 1976. "Capital Market Equilibrium with Restricted Borrowing". The Journal of Business. Vol. 5. (3): p. 444-455.
- Bloomberg. 2015. "Dow Jones Sukuk Index Methodology". Available at https://www.djindices.com/mdsidx/downloads/meth_info/Dow_Jones_Sukuk_Index_Methodology.pdf
- Bollerslev, T. 1986. "Generalized Autoregressive Conditional Heteroskedasticity". Journal of Econometrics. Vol. 31. p. 307-327.
- Bollerslev, T., R.Y. Chou & K.F. Kroner. 1992. "ARCH Modeling in Finance: A Review of the Theory and Empirical Evidence". Journal of Econometrics. Vol. 52. p. 55-59.
- Bollerslev, T., Engle, R.F. and Nelson, D.B. (1994) ARCH Models. Handbook of Econometrics, 4, 2959-3038. [https://doi.org/10.1016/S1573-4412\(05\)80018-2](https://doi.org/10.1016/S1573-4412(05)80018-2)
- Capital Market Centre Asset Management Corporation. 2012. Available at: <<http://english.sukuk.ir/>>
- Chou, R.Y. 1988. "Volatility Persistence and Stock Valuations: Some Empirical Evidence using GARCH". Journal of Applied Econometrics. Vol. 3. (4): p. 279-294. DOI: 10.1002/jae.3950030404.
- Cooray, A.V., & G. Wickramasighe. 2007. "The Efficiency of Emerging Stock Markets: Empirical Evidence from the South Asian Region". Journal of Developing Areas. Vol. 41. (1): p. 171-183.

- Chander, R., K. Mehta, & R. Sharma. 2008. "Empirical Evidences on Weak Form Stock Market Efficiency: The Indian Experience". *Decision*, Vol. 35. (1): p. 75-109.
- Dyckman, T. R. & D. Morse. 1986. *Efficient Capital Markets and Accounting: A Critical Analysis*. Prentice-Hall.
- Ding, Z., R.F. Engle, & C.W.J. Granger. 1993. "A Long Memory Property of Stock Market Returns and a New Model". *Journal of Empirical Finance*. Vol. 1. p. 83-106.
- Emenike, K.O. 2010. "Modelling Stock Returns Volatility in Nigeria using GARCH Models". MPRA Paper No. 22723. Online at <https://mpra.ub.uni-muenchen.de/22723/>.
- Engle, R.F. 1982. "Autoregressive Conditional Heteroskedasticity with Estimates of the Variance of United Kingdom Inflation". *Econometrica* Vol. 50. (4): p. 987-1007.
- Fama, E.F. 1965. "The Behavior of Stock-Market Prices". *Journal of Business*. Vol. 38, (1): p. 34-105.
- Hamid, K., M.T. Suleman, S.A.Z. Shah, & RSI. Akash. 2010. "Testing the Weak form of Efficient Market Hypothesis: Empirical Evidence from Asia-Pacific Markets". *International Research Journal of Finance and Economics*. Vol. 58. p. 121-133.
- International Islamic Financial Market (IIFM) Sukuk Report. 2019. IIFM Sukuk Report. Published July 2019. 8th Edition. <http://www.iifm.net>.
- Hafzian, P., H. Salamon, & M. Shitan. 2015. "Estimating Value At Risk For Sukuk Market Using Generalized Auto Regressive Conditional Heteroskedasticity Models". *The Economics and Finance Letters*. Vol. 2. (2): p. 8-23.
- Haider, J. & M. Azhar. 2010. "Islamic Capital Market Sukuk and its Risk Management in the Current Scenario". Umea University, Faculty of Social Sciences. Umea School of Business. Master thesis. p. 67.
- Jacquier, E., N.G. Polson and P.E. Rossi. 2004. "Bayesian Analysis of Stochastic Volatility Models with Fat-tails and Correlated Errors". *Journal of Econometrics*. Issue 122. p. 185-212.
- Maghyereha, A. I. & B. Awartani. 2016. "Dynamic Transmissions between Sukuk and Bond Markets". *Research in International Business and Finance*. Vol. 38. p. 246-261.
- Modirzadehbami, S. & G. Mansourfar. 2011. *Information Content of Islamic Private Debt Announcement: Evidence from Malaysia*. World Academy of Science, Engineering and Technology.
- Mseddi, S. & N. Naifar (2013). 'Rating Methodology and Evaluating the Issuer of Sukuk'. *International Journal of Management Science and Engineering Management*. DOI: 10.1080/17509653.2013.829629.
- Naifar, N. 2016. Modeling Dependence Structure between Stock Market Volatility and Sukuk Yields: A Nonlinear Study in the Case of Saudi Arabia. *Borsa Istanbul Review*. DOI: <http://dx.doi.org/10.1016/j.bir.2016.01.005>.
- Naifar, N., S. Hammoudeh, & M. S. Al Dohaiman. 2016. Dependence Structure between Sukuk (Islamic Bonds) and Stock Market Conditions: An Empirical Analysis with Archimedean Copulas. *Journal of International Financial Markets, Institutions & Money*. DOI: <http://dx.doi.org/10.1016/j.intfin.2016.05.00>.
- Nelson D.B. 1991. "Conditional Heteroskedasticity in Asset Returns: A New Approach". *Econometrica*. Vol. 59. (2): p. 347 – 370.
- Niyitegeka, O. & B.B. Tewari. 2013. "Volatility Clustering at the Johannesburg Stock Exchange: Investigation and Analysis". *Mediterranean Journal of Social Sciences*. E-ISSN 2039-2117. ISSN 2039-9340. Vol. 4. (14). DOI:10.5901/mjss.2013.v4n14p621.
- Noriza, S. & M. Azhar. 2012. "Sukuk in Malaysian Capital Market". *The 3rd International Conference on Business and Economic Research (3rd ICBER 2012)*. Golden Flower Hotel, Bandung, Indonesia. ISBN: 978-967-5705-05-2. 12 - 13 March.
- Paltrinieri, A., A. Dreassi., S. Miani, & A. Scip. 2015. "In Search of Zero Beta Assets: Evidence from the Sukuk Market". *International Journal of Social, Behavioral, Educational, Economic, Business and Industrial Engineering*. Vol. 9. (1).
- Rahim, S.A. & N. Ahmad. 2016. "Investigating FTSE KLCI Using CAAR Estimations Following Sukuk Announcement in Malaysia: Based on Sukuk Ratings". *Journal of Investment and Management*. Vol. 5 (6): p. 158-165. <https://doi.org/10.11648/j.jim.20160506.19>. ISSN: 2328-7713 (Print); ISSN: 2328-7721 (Online).
- Rahman, M.P. & M.A. Omar. 2012. "Factors Influencing the Excess Returns of Sukuk: An Empirical Analysis on USD Denominated Sukuk Issued by Corporations in the Gulf Cooperation Council (GCC)". *The 3rd Gulf Research Meeting*, University of Cambridge, Cambridge.
- Rahman, M.P., M.A. Omar, & S.H. Kassim. 2013. "An Application of GARCH Modeling on the Malaysian Sukuk Spreads". *Journal of Islamic Finance*. Vol. 2. (2): p. 26-37.
- Rizvi S.A.R. & S. Arshad. 2015. "Investigating the Efficiency of East Asian Stock Markets through Booms and Busts". *Pacific Science Review* 16 (2014). p. 275-279. DOI: <http://dx.doi.org/10.1016/j.pscr.2015.03.003>.
- Rusgianto, S. & N. Ahmad. 2013. "Volatility Behavior of Sukuk Market: An Empirical Analysis of the Dow Jones Citigroup Sukuk Index". *Middle East Journal of Scientific Research*. Vol. 13. p. 93-97. DOI: <http://doi.org/10.5829/idosi.mejsr.2013.13.1887>.
- Scip, A., A. Dreassi, S. Miani, & Andrea Paltrinieri. 2016. "Dynamic Correlations and Volatility Linkages between Stocks and Sukuk: Evidence from International Markets". *Review of Financial Economics Journal*. DOI: <http://dx.doi.org/10.1016/j.rfe.2016.06.005>.
- Securities Commission Malaysia. 2019. "Annual Report of Securities Commission Malaysia 2019". < <http://www.sc.com.my/>>
- Shahida, S. & S. Sapiyi. 2013. "Why Do Firm Issues Sukuk over Bonds? Malaysia Evidence". *Research Centre for Islamic Economic and Finance*. p. 551-573.
- Wang, P. 2003. "Financial Econometrics: Methods and Models". Routledge, London and New York.
- Zivot, E. 2008. "Practical Issues in the Analysis of Univariate GARCH Models". Available at: <https://faculty.washington.edu/ezivot/research/practicalgarchfinal.pdf>

THE INTERACTION BETWEEN ISLAMIC BANKING AND ECONOMIC GROWTH: THE MALAYSIAN EXPERIENCE

Nur 'Izzah Mohamad Zahid^a & Noraziah Che Arshad^b

^a Department of Management, Faculty of Management & Information Technology, Universiti Sultan Azlan Shah

^b Islamic Business School, Universiti Utara Malaysia

Abstract

Islamic banking is the largest sector in the global Islamic finance which is contributing to 70% of assets to the industry according to Islamic Finance Development Indicator Report 2019. The purpose of this paper is to contribute the empirical test to Islamic banking literature by examining the effect of Islamic banks' factors on economic growth from the context in Malaysia. By using a panel regression, the secondary data of 16 Islamic banks have been extracted from the balance sheet and income statement of the annual report while the real gross domestic product (GDP) has been collected from International Monetary Fund (IMF) within a period from 2012 until 2019. The paper presents a three model that shows a significant relationship between the selections of four variables in Islamic banks (total investment, total financing, total deposit, and financing to deposit) and economic growth by local Islamic banks. Meanwhile, foreign Islamic banks are concluded otherwise due to the bank's size.

Keywords: Islamic banks' factors, Local Islamic banks, Foreign Islamic banks, Economic growth.

1.0 INTRODUCTION

According to the IFSB (2019), Islamic banking has emerged in a steady trend since a decade ago. Starting with the oil and gas industry, Islamic banks in the oil-exporting countries spread their capacity into the global market (Abdalla & Abdelbaki, 2014). Hence, it has been announced that Islamic finance assets arose at the global market at approximately US\$2.52 trillion during 2018, while US\$3.47 trillion at previous year (ICD, 2019). Despite the slight decrease in 2014 at US\$ 1.97 trillion, this trend grew steadily since 2014 and expected to reach around US\$3.47 trillion in 2024 according to figure 1. Islamic Finance Development Indicator also reported it has been identified that Islamic banking is the highest sector that contributes to the global Islamic finance asset about 70%. Meanwhile, it is following by sukuk (19%), other IFIs (5%), Islamic funds (4%), and takaful (2%) based on the report.

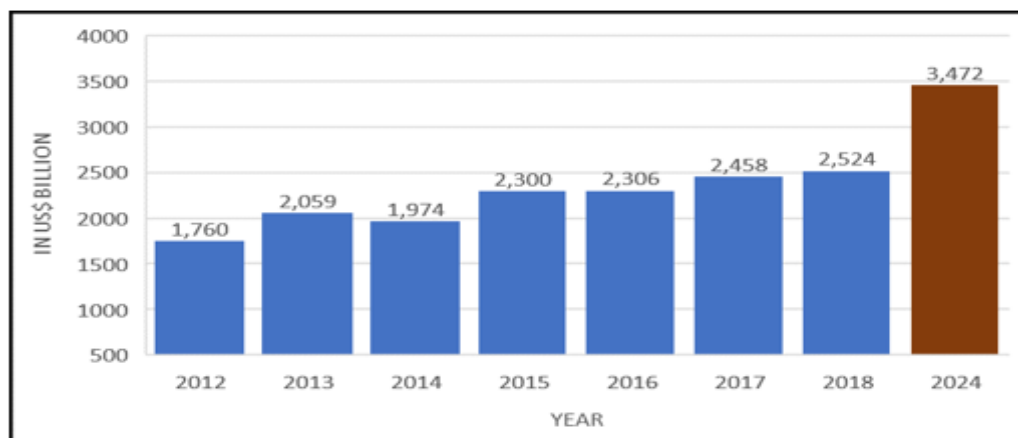

Figure 1: Islamic Finance Assets Growth 2012 – 2018 (USD Billion)

Source: IFDI Report 2019

Malaysia has a progressive GDP growth timely the competency to enter the global market which is well known as ASEAN tigers for its economic development among the ASEAN countries (Ismail et al., 2019). Thus, Malaysia as a developing country responds to this phenomenon by announcing the vision plan 2030 known as Shared Prosperity Vision 2030 and listing down the strategies to achieve the target of the developed country by the year 2030. There are 15 Keys of Economic Growth Activities (KEGA) including Islamic Finance Hub 2.0, Digital Economy,

Industrial Revolution 4.0, Content Industry, ASEAN Hub, Halal and Food Hub, Commodity Malaysia 2.0, Logistic, Transportation and Sustainable Mobility, Coastal and Maritime Economy, Centres of Excellence, Renewable Energy, Green Economy, Smart and High-Value Agriculture, Advanced and Modern Services, and Tourism *Malaysia Truly Asia* (Ministry of Economic Affairs, 2019).

In the meantime, Malaysia is constantly supporting the growth of Islamic banking and finance as much as being exemplified across many regions. As a leading country in Islamic finance, Malaysia shows its example to the global Islamic finance's development with the comprehensive system through the regulatory framework and government injection to mobilize funds under Islamic products. Thus, Malaysia has become a subject of a reference to other countries upon the existence of the Islamic banking system as well as receiving abundant acknowledgements by other countries (Abd. Majid & H. Kassim, 2015). By the years 2019, there are 16 licensed Islamic banks including local and foreign ownership that are taking part in the banking sector in Malaysia. This paper aims to identify the impact of Islamic banks toward the economic growth in Malaysia, both local and foreign banks in recent years.

2.0 LITERATURE REVIEW

There is concern by previous studies on the vital of the Islamic banking sector to develop economic growth in the respective countries. Regardless of various discussions in the finance nexus, the researchers suggest there are at least three types of causality between financial development and economic growth namely demand following, supply leading, and bi-directional causal relationship (Abduh & Azmi Omar, 2012). The theory of Schumpeter's economic development believed that supply leading is the best theory. This is proven by the

ability of the banking sector to channel its fund to the economic sectors especially business activities as suggested by study (King & Levine, 1993).

Economic growth has been the main issue to measure the ability of a country to estimate the total output of goods and services ensuring the movement of the economic cycle in a good condition (Abduh & Azmi Omar, 2012). According to Chirwa & Odhiambo (2016), there are many factors may include being determinants of economic growth. Yet, financial factors are one of the factors which can be seen through the world's effect by the financial crisis 2008. Still, Islamic banking was not affected much by this crisis whereas many businesses and government income melted down at that time. This led to the attention of many players over the resilience of Islamic banking toward financial market around the world (Rosman, Wahab, & Zainol, 2014).

Islamic banks have their own principles compared to conventional banks. Hence, Islamic banks highlight the importance of asset over debt, for instance, sale contract rather than loan contract and profit based rather than interest-bearing products as well as collateral for each debt-based contract. All these are under the application of *maqasid shariah* which prohibits any participation of *riba*, *gharar*, and *maisir* for each transaction contract (Akram Laldin & Furqani, 2013). Moreover, each element of the contract also comprises very details all the conditions to involve in each contract. In the context of Malaysia, each contract has been very detailed and clear in the *shariah* standards and operational requirements as outlined by the Shariah Advisory Council and compulsory to be followed by Malaysian Islamic banks (SAC, 2018).

Total asset is commonly referred to as the bank's size. This is the reason that Zirek, Celebi, & Kabir Hassan (2016) includes total Islamic bank's asset as one of the factors in their study. The result found that total asset is significantly related to the economic growth in OIC countries within the period from 1999 until 2011 by using Vector Autoregressive (VAR) analysis method. Additionally, it is confirmed that profitability in Islamic banks is influenced by the bank's size from a study on the determinants of Islamic banks' profitability in Malaysia between 2006 and 2010 (Abduh & Yameen, 2013).

It is suggested that total investment in the banks is defined as total securities invested by banks (Abbassi, Iyer, Peydró, & Tous, 2016). Thus, Zarrouk et al. (2017) emphasize that Islamic financial development may develop economic growth in the United Arab Emirates (UAE) as one of the main drivers to boost economic activities in that country. This study has included total investment as on the indicator for Islamic banking from the period 1990 until 2012 quarterly by employing time series data within that year.

Total financing is a common benchmark to represent Islamic banking sector in the numerous studies related to the banking sector and economic growth (Abduh & Chowdhury, 2012; Furqani & Mulyany, 2009; Jobarteh & Mustapha, 2017; Nawaz et al., 2019; Tabash & Dhankar, 2014; Zarrouk et al., 2017). Significantly, all those finding results are positively related to the economic development in the respective country. On a quarterly basis from 2006 until 2014, it is revealed that total financing contributes to the economic growth in Malaysia, following to the

supply leading relationship (Wahabet al., 2016).

According to Rawat & Mehdi (2017), total deposit has been used to represent the Islamic banking sector which results in the significant impacts between Islamic banking and Pakistan's GDP. It stimulates the developing economy of the country from 2009 to 2014 by employing panel data. The same result was obtained in the recent study by using time series data during period 2004Q1 – 2018Q4 (Afidah & Yusof, 2020). This finding found existing of a long-run relationship between the total deposit in Islamic banks and the economic growth of Malaysia.

Both total financing and deposit are very significant to the function of financial intermediaries as well as to the economic growth (Kassim, 2016). By employing panel data regression analysis, it is identified that the performance of banks are influenced by the financing to deposit factor or precisely the bank's liquidity management during the year 2010 until 2005 (Samail et al., 2018). The good management between those funds are crucial in channelling from the surplus to the shortage components such as household or firm groups which gives impact to the economic activity (Ang, 2008).

In common practice, total financing must be associated with the risk of non-payment or event of default by customers which gives negative effects to the financial institution (Soekapdjo et al., 2018). This has been controlled under the credit risk to mitigate the higher risk incurred from this type of risk. The efficiency of credit risk management will result in higher profitability as well as improvement to the bank performance based on the study by using panel data analysis from 2008 to 2016 (Uda et al., 2018).

3.0 DATA AND METHODOLOGY

This study employs the panel data of Islamic banks from annual financial reports of all 16 licensed Islamic banks including local and foreign-owned banks and Real Gross Domestic Product is collected by International Monetary Fund from the annual period 2012 until 2019. This selected time is considering based on the development of Islamic banking for recent years.

Therefore, to represent economic growth, real gross domestic product (GDP) or GDP at current price has been selected. Meanwhile, total asset, total investment, total financing, total deposit, financing to deposit, and non-performing financing are representing Islamic banks' indicators. All six independent variables are considered in this study to identify the impacts of those variables toward the growth between eight years as shown in table 1.

Panel data

Panel data is a combination between the time series data and cross-sectional data which examines few effects such as time effect or group effect or both in one way. This is to deal with heterogeneity or individual effect which is considerable for observing later (Baltagi, 2005). These effects are known as the fixed effect or random effect. Thus, the Hausman Test is applicable to choose between fixed-effect models (FEM) or a random effect model (REM). Daly & Frikha (2016) believes that Hausman test is the best way to determine the panel data of banks' effect on economic growth in the few developing countries.

Regression analysis

According to Saunders et al. (2009), regression is where a change in one or more independent variables causes a change in the dependent variable. In other words, it will create a cause and effect relationship. Typically, the regression coefficient of multiple determination can assess the strength of a cause and effect relationship between variables and is represented as R^2 or any value displayed between 0 and +1.

Table 1: Summary of Operational Definition and Measurement of Variables

Variables	Measurement	Notation
<u>Dependent Variable</u> Gross Domestic Product	Real GDP	LNGDP
<u>Independent Variables</u> Total Asset	Natural Logarithm of Total Asset	LNTA
Total Investment	Natural Logarithm of Total Investment	LNTI
Total Financing	Natural Logarithm of Total Financing	LNTF
Total Deposit	Natural Logarithm of Total Deposit	LNTD
Financing to Deposit	$\frac{\text{Gross Financing}}{\text{Total Deposit}}$	FD
Non-Performing Financing	$\frac{\text{Gross Impaired Financing}}{\text{Gross Financing}}$	NPF

By employing three linear regression, this paper observes the relationship between Islamic banking and economic growth in Malaysia. The first model is within the local Islamic banks only while model 2 includes foreign banks only, and the third model is a combination of both local and foreign Islamic banks in Malaysia. Following are the regression equations:-

$$\begin{aligned} \text{Model 1 (Local banks only)} &= \text{LnGDP}_{it} = \beta_0 + \beta_1 \text{LnTA}_{it} + \beta_2 \text{LnTI}_{it} + \beta_3 \text{LnTF}_{it} + \beta_4 \text{LnTD}_{it} \\ &\quad + \beta_5 \text{FD}_{it} + \beta_6 \text{NPF}_{it} + \varepsilon_{it} \\ \text{Model 2 (Foreign banks only)} &= \text{LnGDP}_{it} = \beta_0 + \beta_1 \text{LnTA}_{it} + \beta_2 \text{LnTI}_{it} + \beta_3 \text{LnTF}_{it} + \beta_4 \text{LnTD}_{it} \\ &\quad + \beta_5 \text{FD}_{it} + \beta_6 \text{NPF}_{it} + \varepsilon_{it} \\ \text{Model 3 (All banks)} &= \text{LnGDP}_{it} = \beta_0 + \beta_1 \text{LnTA}_{it} + \beta_2 \text{LnTI}_{it} + \beta_3 \text{LnTF}_{it} + \beta_4 \text{LnTD}_{it} \\ &\quad + \beta_5 \text{FD}_{it} + \beta_6 \text{NPF}_{it} + \varepsilon_{it} \end{aligned}$$

Where, β_0 = constant

i = country

t = time period

ε_{it} = Error term of country i on time t

Dependent variable:

GDP = Economic growth

Independent variables:

TA = Total Asset

TI = Total Investment

TF = Total Financing

TD = Total Deposit

FD = Financing to deposit

NPF = Non-Performing Financing

4.0 FINDING AND DISCUSSION

This analysis estimates the result based on the panel regression analysis, by including the Hausman Test in order to choose between Fixed Effect or Random effect Model for each model as shown in the table 2.

Table 2: Summary on regression result

Variables	(1)	(2)	(3)
	Local Banks Fixed Effect	Foreign Banks Random Effect	All Banks Fixed Effect
LNTA (Coef.) (Std. Error)	-0.162 (0.168)	0.113 (0.259)	0.121 (0.183)
LNTI	0.047* (0.026)	0.026 (0.027)	0.041 (0.026)
LNTF	0.814*** (0.152)	0.210 (0.536)	1.052*** (0.213)
LNTD	-0.364* (0.205)	-0.287 (0.519)	-1.059** (0.300)
FD	-0.600*** (0.140)	-0.143 (0.391)	-0.742** (0.207)
NPF	-0.894 (1.120)	-0.226 (0.656)	1.002 (0.684)
R-Square	0.8897	0.0994	0.4812
F-Value	F (6,82) Prob>F 0.000	F (6,46) Prob>chi2 0.6356	F (6,128) Prob>F 0.000

Note:

- Figures in the parentheses are coefficient and standard error values.
- *p<0.10, **p<0.05, ***p<0.01.
- LNGDP is a dependent variable to represent growth.

Model 1

It has been identified that the Fixed Effect Model is the most appropriate for model 1. The result shows that LNTF and FD have a significant association with the growth at a significance level of 1% whereas LNTI and LNTD have statistically significant at 10% to LNGDP. Meanwhile, LNTA and NPF have no significance with LNGDP. The

result showed that LNTF is positively and significantly related to economic growth. These results reveal that the improvement of the Islamic financial system in these countries may benefit economic development.

Model 2

The result has shown that model 2 fits for Random Effect Model. It is also implied to the insignificance of each variable in foreign Islamic banks regardless of 1%, 5%, or 10% of significance levels. It is found that LNTA, LNTI, and LNTF have a positive association with the growth as a 1% increase in three variables will lead to an increase of growth by 0.113, 0.026, 0.210 respectively although they are not significant to growth.

Model 3

Fixed Effect Model is appropriate in model 3. It is estimated that LNTF is significant at a 1% significance level while LNTD and FD are significantly related to LNGDP at a 5% significance level. These results are consistent with other studies which suggest that total deposit and total financing are statistically significant toward economic growth. Precisely, total financing shows a significant relationship in the long run and short run, while total deposit found to be in the long run only (Afidah & Yusof, 2020; Kassim, 2016).

Interestingly, the total asset of Islamic banks indicates an insignificant result in growth by all the models employed. Additionally, the total asset in the local Islamic banks indicates for negative impact on economic growth. This is similar to the previous study, Daly & Frikha (2016) found that total asset is insignificant to the growth in few countries with a high population of 60% Muslims around the world such as Bahrain, Egypt, Kuwait, Pakistan and others which the banking data is arranged between year 2005 until 2012 by using panel data set.

Overall, total investment and total financing remain to be positively related to the growth in all models while total deposit and financing to deposit have negatively related to economic growth. Although total investment is significant within the local Islamic banks only, it may contribute to the GDP at a small scale for all Islamic banks' combination eventually. The rest variables have uncertain result for each model conducted. The different results for each model signify different interaction by local banks, foreign banks, and combination of all Islamic banks toward growth between 2012 until 2019.

5.0 CONCLUSION

Based on the finding, it shows that all local Islamic banks are significantly related to growth by the total investment, total financing, total deposit, and financing to deposit. Nevertheless, foreign Islamic banks are insignificant to the growth that might be due to the bank's size. According to Abduh & Yameen (2013), the performance of banks is associated with the bank's size and this is an impact from the lower volume. Despite the insignificant result, foreign Islamic bank still has a positive relationship to the economic development of Malaysia estimated by the slight contribution especially in its total financing, total asset, and total investment.

Furthermore, the combination of 16 Islamic banks resulted in a significant relationship for total financing, total deposit, and financing to deposit toward growth. Interestingly, total financing remains a positive and significant relationship for the two models tested empirically. This finding may support the supply and leading relationship theory that emphasizes the importance of the banking sector to channel funds into real economic activities similar to the previous study (Abd. Majid & H. Kassim, 2015).

Malaysia is a developing country that is moving to a developed country by 2030. Any sector may contribute to boosting economic development. Yet, Islamic banking as one of the Islamic financial market's components has its ability to play the role of achieving this vision. This paper signifies the importance of the financial sector to mobilize funds to the entrepreneur as well as to households to run economic activities among those groups. Further research may add a few variables based on the type of contracts used in the financing and investment products of each Islamic bank in Malaysia. Both types of products are very important as uses of funds to the financial institutions with different Shariah standards applied to each contract. It would be interesting if financial technology (fintech) in Islamic financial institutions is included as well since financial industries are heading toward digital banking at future.

REFERENCES

- Abbassi, P., Iyer, R., Peydró, J. L., & Tous, F. R. (2016). Securities trading by banks and credit supply: Micro-evidence from the crisis. *Journal of Financial Economics*, 121(3), 569–594.
- Abd. Majid, M. S., & H. Kassim, S. (2015). Assessing the contribution of Islamic finance to economic growth: Empirical evidence from Malaysia. *Journal of Islamic Accounting and Business Research*, 6(2), 292–310.
- Abdalla, M. A., & Abdelbaki, H. H. (2014). Determinants of Economic Growth in GCC Economies. *Asian Journal of Research in Business Economics and Management*, 4(11), 46.
- Abduh, M., & Azmi Omar, M. (2012). Islamic banking and economic growth: the Indonesian experience. *International Journal of Islamic and Middle Eastern Finance and Management*, 5(1), 35–47.
- Abduh, M., & Chowdhury, N. (2012). Does Islamic Banking Matter for Economic Growth in Bangladesh. *Journal of Islamic Economics, Banking and Finance*, 8(July), 104–113.
- Abduh, M., & Yameen, I. (2013). Determinants of Islamic Banking Profitability in Malaysia. *Australian Journal of Basic and Applied Sciences*, 7(2), 204–210.
- Afidah, N., & Yusof, M. (2020). Islamic Banking and Economic Growth in Malaysia: Evidence of a Causal Relationship Pre and Post Regulatory Reform. *Journal of Entrepreneurship and Business*, 8(1), 1–14.
- Akram Laldin, M., & Furqani, H. (2013). Developing Islamic finance in the framework of maqasid al-Shari'ah: Understanding the ends (maqasid) and the means (wasa'il). *International Journal of Islamic and Middle Eastern Finance and Management*, 6(4), 278–289.
- Baltagi, B. H. (2005). *Econometric Analysis of Panel Data* (3rd Editio). UK: John Wiley Sons.
- Chirwa, T. G., & Odhiambo, N. M. (2016). Macroeconomic determinants of economic growth: A review of international literature. *South East European Journal of Economics and Business*, 11(2), 33–47.
- Daly, S., & Frikha, M. (2016). Banks and economic growth in developing countries: What about Islamic banks? *Cogent Economics and Finance*, 4(1), 1–26.
- Furqani, H., & Mulyany, R. (2009). Islamic banking and economic growth: Empirical evidence from Malaysia. *Journal of Economic Cooperation and Development*, 30(2), 59–74.
- ICD. (2019). *Islamic Finance Development Indicator Report (IFDI): Shifting Dynamics*. Saudi Arabia.
- IFSB. (2019). *Islamic Financial Services Industry (IFSI): Stability Report*. Malaysia, Kuala Lumpur.
- Ismail, F., Ab-Rahim, R., & Pei-Chin, L. (2019). Nexus Between Financial Development and Economic Growth in Malaysia. *International Journal of Academic Research in Business and Social Sciences*, 9(1), 26–44.
- Jobarteh, & Mustapha. (2017). Islamic Finance Development and Economic Growth: Empirical Evidence From Turkey. *Turkish Journal of Islamic Economics*, 4(1), 31–47.
- Kassim, S. (2016). Islamic finance and economic growth: The Malaysian experience. *Global Finance Journal*, 30, 66–76. 7
- King, R. G., & Levine, R. (1993). Finance and Growth: Schumpeter Might Be Right. *The Quarterly Journal of Economics*, 108(August 1993), 717–737.
- Ministry of Economic Affairs. (2019). Graf dan infografik Wawasan Kemakmuran Bersama 2030. *Wawasan Kemakmuran Bersama 2030*, 1–49.
- Nawaz, H., Abrar, M., Salman, A., & Bukhari, S. M. H. (2019). Beyond finance: Impact of Islamic finance on economic growth in Pakistan. *Economic Journal of Emerging Markets*, 11(1), 8–18.
- Rawat, A. S., & Mehdi, S. K. (2017). The Impact of Islamic Banks and Takaful Companies on Economic Growth: A Case of Pakistan. *Journal of Finance & Economics Research*, 2(2), 130–143.
- Rosman, R., Wahab, N. A., & Zainol, Z. (2014). Efficiency of Islamic banks during the financial crisis: An analysis of Middle Eastern and Asian countries. *Pacific Basin Finance Journal*, 28, 76–90.
- SAC. (2018). Shariah Standards & Operational Requirement. Retrieved August 28, 2020, from Shariah Advisory Council, Bank Negara Malaysia website: http://www.sacbnm.org/?page_id=3318
- Samail, N. A., Zaidi, N. S., Mohamed, A. S., & Kamaruzaman, M. N. (2018). Determinants of financial performance of Islamic banking in Malaysia. *International Journal of Academic Research in Accounting, Finance and Management Sciences*, 8(4), 21–29.
- Saunders, M., Lewis, P., & Thornhill, A. (2009). *Research methods for business students* (5th ed.). Harlow: Pearson Education.
- Soekapdjo, S., Nugroho, L., Badawi, A., & Utami, W. (2018). Bad Debt Issues in Islamic Bank: Macro and Micro Influencing (Indonesia Cases). *International Journal of Commerce and Finance*, 4(1), 10–26.
- Tabash, M., & Dhankar, R. S. (2014). Islamic Banking and Economic Growth: An Empirical Evidence from Qatar. *Journal of Applied Economics and Business*, 2(March, 2014), 51–67.
- Uda, N. A. Z. @, Hamid, M. A., & Janor, H. binti. (2018). Determinants of Credit Risk in Islamic and Conventional Bank: Evidence from Malaysia. *International Journal of Academic Research in Business and Social Sciences*, 8(6), 1054–1068.
- Wahab, M., Mufti, O., Murad, M. S., & Arif-ul-Haq. (2016). The Study of Co-integration and Causal Link between Islamic Bank Financing and Economic Growth. *Abasyn Journal of Social Sciences – Special Issue*, 9, 134–146.
- Zarouk, H., El Ghak, T., & Abu Al Haija, E. (2017). Financial development, Islamic finance and economic growth: evidence of the UAE. *Journal of Islamic Accounting and Business Research*, 8(1), 2–22.
- Zirek, D., Celebi, F., & Kabir Hassan, M. (2016). The Islamic banking and economic growth nexus: A panel VAR analysis for organization of Islamic cooperation (OIC) countries. *Journal of Economic Cooperation and Development*, 37(1), 69–100.

FACTOR ANALYSIS ON FINANCIAL RATIOS TO DETERMINE FINANCIAL DISTRESS OF ISLAMIC BANKS IN MALAYSIA.

Siti Raihana Hamzah^{*a}, Nur 'Arifah Ghazali^b & Karmila Hanim Kamil^c

^{abc} Universiti Sains Islam Malaysia (USIM), Malaysia

Abstract

The aftermath of the global financial crisis 2007/2008; insolvency, credit risk and bankruptcy risk have been widely discussed in business literature. Constituting the largest industry in Malaysia, banking industry is not excluded from the impact left by the crisis. Especially when credit creation is the core business of banking institutions, credit risk exposure has become the direct exposure to the industry. In fact, researchers intensified the importance of credit risk management in the banking industry in order to control the risk of bankruptcy, especially during financial turmoil. This paper would like to examine the credit risk exposure among Islamic banks in Malaysia by defining the factor groups of financial ratios that could indicate the financial distress occurrence of the banks. This paper use principal component analysis (PCA) and factor analysis on 20 financial ratios ranging from 2010 to 2019 of 10 Islamic banks in Malaysia in order to identify the suitable ratio to measure financial distress of a bank. From the factor analysis, this paper would identify the financial healthiness of the Islamic banks in Malaysia and its possible sustainability against an economic downturn. This result is important for Malaysia as the hub of the Islamic financial market, with the majority of the population are Muslim. The strong credit risk management of the Islamic banks in Malaysia may strengthen the interest and confidence of the client on the Islamic financial market other than making Islamic banks better resilience against any financial shocks. From the analysis, this study found that 12 financial ratios are significance to determine the financial distress of a bank. These financial ratios are further grouped into four factors which then strengthen the analysis of the study.

Keywords: Credit Risk, Factor Analysis, Financial Distress, Financial Ratio, Islamic Bank.

INTRODUCTION

Credit creation is known to be the core business of banking institutions. It renders the lending activities between the institutions and the borrower whereby the latter requires to provide a fixed pre-determined return to the institution over a specified duration (Abdul Manab, Theng, & Md Rus, 2015). In Malaysia, 70% of the industry is of financial institution with banks give significant contributions to the development of economy in Malaysia (Safiullah, 2010; Buckova, 2011 & Gebreslassie, 2015). In addition, almost all instruments or products offered by the banks to the customers are subjected and exposed to credit risk and each bank have a different level of exposure according to the way they managed the risk (Misman & Bhatti, 2010). Since the banks' main activities are servicing credit to the customers, thus, many researchers have identified credit risk exposure is the most prominent risk in the banking sectors. The intensity of credit risks in an institution could endanger the bankruptcy risks of the institutions and parties involved (Basel Committee, 2001; Vodova, 2003; Safaei, Safari & Farahmand, 2014; Abdul Rahman, 2014 and Uda, Hamid & Janor, 2018). In fact, the extent or credit risk exposure primarily via the escalation of the non-performing loan of banking institutions may lead to the higher financial distress and the possibility of bankruptcy (Brownbridge, 1998 and Gebreslassie, 2015).

The powerful impact of credit can be seen when the world experienced the worse credit crisis in 2007/2008. It began when the decline of the housing prices in the United States has resulted to default on loans and devaluation of housing-related securities. The situation which was known as subprime mortgage crisis has affected not only the conglomerates, Ramadhan and Naseeb (2015) identified that crisis caused has caused major insolvency of many financial institutions in United States and surround the world. The credit crisis 2007/2008 also did not leave Islamic banks operation impact less. Even if some of the researchers conclude that Islamic banks have less impacted, but the damage of the credit crisis still been experienced by this Islamic sector (Magd & McCoy, 2014 and Budiman, Herwany & Kristanti, 2017). Abu Hussain and Al-Ajmi (2012) emphasized that the risk of credit is dominant in Islamic banks and could risk the banks' sustainability. In the recent examples Nurul Husna & Abdul Rahman (2012) elaborated that Dubai Islamic Bank, Kuwait Finance House and al-Rajhi Bank in Saudi Arabia were severely affected in the mid-2008 crisis due to diminishing stocks of the bankers. With regards to the crisis faced by Dubai

government, two Islamic banks in that country which is Islamic al-Hilal Bank in Abu Dhabi and Noor Islamic Bank of Dubai also affected even though the banks had good liquidity.

Due to the escalation of awareness on the financial sustainability following the Asian financial crisis, the global financial crisis 2007/2008 witnessed Asian economics, and financial markets did better as compare to the crisis on 1997/1998. Following the crisis, many Malaysian companies was restructured as most of the companies was affected by the crisis, and many companies fall into bankruptcy (Ferri, Hahm, & Bongini, 1998). Furthermore, Malaysian ringgit depreciated by 50 per cent and stock market go down by 60 per cent (Ariff & Abubakar, 1999). Financial distress gives a huge impact not only to the financial sector but also the real sector of the economy. Economy of Malaysia experienced a recession after the real sector knocked down with business disclosure, high unemployment due to retrenchments and inflation levels rose. Meanwhile, increase in non-performing loans (NPLs) of the financial sector was reflected in a sharp downturn in borrowing and financing, bringing about tight liquidity (Abubakar, 2002).

In summary, financial crisis verified the danger of the debt and credit to the overall financial system. Excessive debt activities may lead to the credit crisis and hence global financial collapse. Due to that, regulators and economists surround the world try to identify the best way to control the debt activities and to tighten other financial activities in order to mitigate future financial crisis. With the controversial issue on debt and its relation to the crisis, many researchers investigate the ability of Islamic banking operational activities to control the exposure to the future financial crisis. Islamic banking comes to the picture due to its natural operations which are against the debt financing. With regards to that, this thesis would like to fill the gap by exploring the exposure of financial distress among Islamic banks in Malaysia. Other than that, Malaysia which is one of the ASEAN countries is the long-time hub for Islamic financial and banking system, in which may have advance step to mitigate the financial vulnerability.

2.0 LITERATURE REVIEW

Credit risk is referring to the loss when a loan borrower is not able to repay a loan or not able to honor contract obligation. Anita (2008) further defined credit risk exposure to the banks as a possibility of loss of valuable assets caused by borrowers with low creditworthiness and inability to obligate their contracts. Hence, the inability of a banks to generate income in order to meet the banks' financial obligation would cause the banks to be financially distressed. Indirectly, the low creditworthiness of the borrowers may increase the occurrence of default which then increase the exposure of credit risk to the banks and lead the bank to the financially distressed state with a high risk of bankruptcy (Anita, 2008). Bankruptcy or default occurred when a company failed to meet their obligation or fulfil their payments to the creditors. The uncertainty to meet the credit term to the creditors is called as a credit risk exposure. In financial institution, credit risk becomes an essential risk or key risk due to the nature of its business primarily relies on loans lending and deposit activities (El-Bannany, 2015). The greatest credit risk that banks and financial intermediaries face is the possibility of default by consumers or the counterparty (Samuel, 2014).

Most of the analysis of credit risk exposure to the banks highlighted the level of credit risk exposure may influence the banks' financial performance, as a whole. An increase of non-performing loans could deteriorate banks' profitability by 46.3%. With the rise of credit risk exposure, it could expose banks to great illiquidity and distress. Abu Bakar & Mohd Tahir (2009) conducted a multilinear regression study and developed artificial neural networks to predict the performance of banks in Malaysia. And it was found that the credit risk and the cost of income ratio are important in deciding bank performance. Similarly, a study by Al-Eitan & Khalid (2019) also shared the same result as above. Due financial instability in Middle East region, many commercial banks located in Jordan are more exposed the danger of credit risk which can threaten banks' financial and credit stability. The finding the study showed that credit risk has negative significant impact on both ROA and ROE. An increment in credit risk exposure can decrease the banks' performance financially. While total deposits and bank size have positive and significant impact on financial performance of these commercial banks in Jordan. Thus, other than keeping close eyes on non-performing loans, the study emphasizes the need of credit risk management to predict clients' situation and determine the probability of default in order to reduce the exposure of risk in a bank.

Abdul Karim (2014) also found that financial distress in Malaysia are mostly caused by the non-performing loans (NPL). A study was carried using OLS multiple linear regression estimation and focuses on eight Malaysian commercial banks for period between 1990 to 2010 to measure the relationship between the return equity (ROE), the proxy for bank's financial performance, and the bank's internal and external factors namely bank financial distress, bank size, economic growth, interest rate and inflation rate. The overall results showed that NPL mostly influenced the financial performance of the banks. Huge amount of NPL in a bank contributes to lower banks'

profitability and performance. The bad loans had caused customers to lose interest and trust towards banks. Thus, worsen the banks' primary resources. When the banks cannot handle their NPL or had issues with customers' inability to repay what they had borrowed, credit risk in the banks would arise and the banks will experience financially distressed.

The study is supported by Ekinçi & Poyraz (2019) which agreed that NPL give negative relationship on both ROA and ROE of an institutions. The panel study was conducted by using data of 26 commercial banks operating in Turkey for the year 2005 until 2017 to study the effect of credit risk on financial performance of deposit banks in Turkey. The negative relationship between credit risk and ROA as well as credit risk and ROE means that as NPL rises, it leads to a reduction in the capital used by banks to carry out their investments and activities. So, the profits of banks will decrease as well. Thus, it can be concluded that credit risk reduces the financial performance of banks. The increments of credit risk in banking sector especially in Turkey has increase the importance of credit risk management. Banks should focus more on credit risk management, especially on the control and monitoring of non-performing loans. In addition, managers should focus more on modern credit risk management techniques in order to mitigate the risk of credit.

Other paper by Gebreslassie (2015) also relates the likeliness of high NPL ratio to contribute to the increase of banks' financial distress. The paper analysed the determinants of financial distress of banks in Ethiopia. The findings reveal that non-performing loan ratio can decrease the financial health of a bank while capital to loan ratio and net interest income to total revenue ratio are significantly positive to the financial health of the bank. These arguments supported by Brownbridge (1998) who has studied the cause of financial distress in local banks in Africa. The result found that non-performing loans caused insolvency and illiquidity of banks and this leads to the closure of many of the local banks setup in Kenya, Nigeria, Uganda and Zambia taken over by their Central Banks. Other than that, moral hazard and adverse selection give effect to the bad debt problems of the banks. Moral hazard contributed to the highly imprudent, and in some cases fraudulent, lending strategies of many of the failed banks. Furthermore, Ngunjiri (2016) support the study and states that due to insolvency and illiquidity caused by non-performing loans, many of the local banks set up in Kenya have been closed or taken over by their Central Bank of Kenya (CBK).

Meanwhile, Abdul Rahman (2014) used CAMELS in detecting financial distress of Islamic banks in Malaysia. By using neural network, this study analyse data from 2006 to 2010 to study whether capital adequacy, asset quality, management, efficiency, liquidity and shariah compliance have effect on performance of Islamic banks in Malaysia. The result showed that, found that CAMEL ratings system can be a good measurement to predict the financial distress of Islamic banks. In addition, the neural network methodology was found to have the ability to predict future financial possibilities by using historical data. Thus, the result of using the combination of CAMEL ratings system and neural network was found to be able to develop a good financial distress-detection model and thus can help Islamic banks in Malaysia to forecast their future performance and efficiency.

The result of the inability to reduce credit risk in bank institutions merely not only lead to financial distress but worse, financial crisis. El-Bannany (2015) states that credit risk is the main cause of global financial crisis which in turn might lead to serious liquidity problem to the firms and hence go for bankruptcy. Financial crisis happens when asset prices start to decline in value, businesses and consumers unable to pay the debts and liquidity shortage experienced by financial institutions. During the height of financial crisis, bank lending activities has been affected. Cornett et. al. (2011) analysed the impact of the financial crisis on credit supply during the 2007-2009 financial crisis. The paper concluded that credit production during the crisis declined due to liquidity risk exposure.

3.0 METHODOLOGY

This study uses factor analysis on financial ratios to determine financial distress of ten Islamic banks in Malaysia (Affin Islamic Bank Berhad, AmBank Islamic Berhad, Bank Islam Malaysia Berhad, Bank Muamalat Malaysia Berhad, CIMB Islamic Bank Berhad, Hong Leong Islamic Bank Berhad, Maybank Islamic Berhad, OCBC Al-Amin Bank Berhad, RHB Islamic Bank Berhad and Standard Chartered Saadiq Berhad).

3.1 Sample

The data sample come from secondary data extracted from the annual reports of selected Islamic banks in Malaysia where the reports are publicly published in the banks' websites. Other than that, this study also collects data from financial statements in *Fitch Connect* and *Bloomberg*. All data are based on the annual data for the period between 2010 and 2019. Yearly data for each Islamic bank has been utilized with the belief that the high frequency of the accessibility of the relevant data will accurately reflect whatever changes and alterations in the financial condition

of the bank. 10 Islamic banks from Malaysia were selected for study sample and follow the following criteria: they must have published complete data for the period between 2010 and 2019.

3.2 Variable Selection

The first step of conducting this study is to select suitable financial ratios which are significant for predicting banks' failure. In monitoring the financial condition of the financial institutions, the CAMELS approach was used by many regulators around the world. CAMELS rating systems were used by regulators to indicate safety and soundness of banks (Othman, 2013). CAMEL analysis is part of risk assessment to forecast the estimation of financial distress that has existed in the past, current or future used to improve profitability for internal and external management in making decisions on banking performance (Badrul Munir & Bustamam, 2017). The 'CAMELS' term stands for, Capital Adequacy, Asset Quality, Management, Earnings, Liquidity, and Sensitivity to Market Risk. Financial ratios have been used by banks as testing risk in order to manage the risk efficiently (Badrul Munir & Bustamam, 2017). Discriminant analysis is among the leading and most utilised statistical technique used to analyse and predict bank failures (Othman, 2013).

Therefore, this study adopted financial ratios to predict the performance of business in Islamic banks, where ratios are selected and defined as Table 1. For the purpose of this research, 20 financial ratios have been selected and classified into seven main categories, which are capital ratios, asset quality ratios, liquidity ratios, profitability ratios, income-expenditure structured ratios, management ratio and leverage ratio as independent variables to estimate the models. In analyzing the selected financial ratios, SPSS statistical software package and E-views software have been employed.

Table 1. Selected Financial Ratios

Category	Ratios	Definition
Capital Ratios	CR1	(Shareholders' Equity) / Total Assets
	CR2	(Shareholders' Equity) / (Total Assets + Contingencies and Commitments)
	CR3	Shareholders' Equity / Total Financing
Asset Quality Ratios	AQ1	Total Financing / Total Assets
	AQ2	Non-performing Financing / Total Financing
	AQ3	Permanent Assets / Total Assets
	AQ4	Specific Provision / Total Financing
Liquidity Ratios	LR1	Total Deposits / Total Financing
	LR2	Total Financing / Total Deposits
Profitability Ratios	PR1	Net Income (Loss) / Total Assets
	PR2	Net Income (Loss) / Average Shareholders' Equity
	PR3	Net Income before Tax / Total Assets
	PR4	Provision for Financing Losses / Total Assets
Income-Expenditure Structured Ratios	IE1	Net Interest Income After Provision / Assets
	IE2	Interest Income / Interest Expenses
Management Ratio	M1	Interest Expenses/Total Deposits
Leverage Ratio	LE1	Total Liabilities/Total Asset
	LE2	Total Assets/Total Equity

4.0 ANALYSIS AND RESULT

In obtaining the objective of this study, test of relevance of the independent variables is done using ANOVA test. Through the mean between healthy and non-healthy banks' financial ratios, the validity of variables is studied at 10 percent significance level. Eviews software is applied to analyse the data in order to achieve this stage's objective. By using the independent t-test on financial ratios, the results are presented in Table 2, which presents descriptive statistics of the financial ratios for the two groups (healthy and non-healthy banks), and significance tests for the equality of group means for each ratio.

Table 2. The ranking scores and grouping of healthy and non -healthy banks.

Code	Definition	Healthy banks		Non-healthy banks		Test statistics		Accept/ reject
		Mean	SD	Mean	SD	F	Sig	
CR1	Shareholders' equity/total assets	0.069	0.016	0.071	0.013	1.486	0.191	Accept
CR2	Shareholders' equity/ (total assets + contingencies and commitments)	0.050	0.013	0.050	0.011	1.271	0.429	Accept
CR3	Financing/shareholder's equity	10.116	4.097	9.436	2.124	3.722	0.000	Reject***
CR4	Shareholder's equity/total financing	0.121	0.075	0.112	0.030	6.262	0.000	Reject***
AQ1	Loans/total assets	0.659	0.252	0.645	0.087	8.432	0.000	Reject***
AQ2	Non-performing loans/loans	0.019	0.014	0.016	0.013	1.105	0.749	Accept
AQ3	Permanent assets/total assets	0.006	0.013	0.001	0.000	936.208	0.000	Reject***
AQ4	Specific provision/total financing	0.003	0.004	0.681	1.601	0.000	0.000	Reject***
LR1	Total Deposits/Total Loans	1.456	0.809	1.095	0.340	5.650	0.000	Reject***
LR2	Total financing/total deposits	0.813	0.331	1.056	0.515	0.412	0.002	Reject***
PR1	Net income (loss)/total assets	0.023	0.007	0.020	0.005	1.822	0.049	Reject***
PR2	Net income (loss)/shareholders' equity	0.343	0.079	0.282	0.066	1.419	0.248	Accept
PR3	Net income before tax/total asset	0.010	0.003	0.009	0.003	0.802	0.436	Accept
PR4	Provision for loan losses/total assets	0.002	0.002	0.451	1.041	0.000	0.000	Reject***
IE1	Net interest income after provision/total asset	0.047	0.008	0.043	0.006	1.755	0.064	Reject***
IE2	Interest income/interest expenses	2.218	0.502	2.183	0.547	0.843	0.545	Accept
M1	Interest expenses/total deposits	0.027	0.006	0.035	0.016	0.145	0.000	Reject***
LE1	Total liabilities/total equity	14.338	3.827	13.576	2.383	2.579	0.002	Reject***
LE2	Total liabilities/total assets	0.931	0.018	0.929	0.013	1.962	0.027	Reject***
LE3	Total assets/total equity	15.341	3.830	14.576	2.382	2.585	0.002	Reject***

The null hypothesis for this test is as follow:

$$H_0: \text{Two group means are equal}$$

As a result, out of 20 ratios used in the early stage of analysis, only 14 are established to be statistically significant at <10%. Hence, the null hypothesis that the two-group means are equal is rejected at 10% significance level of these ratios. The rest of the ratios, with higher significance level (>10%), was omitted from the analysis due to inability to separate the Islamic banks into healthy and nonhealthy. In other words, the equality of group means for these remaining ratios cannot be rejected at 10% significance level.

Next, multicollinearity test was conducted, and the result found that out of 14 variables, two variable which is LE1 and LE3 has high value of R² and VIF which mean the explanatory variable is correlated with another independent variable. Therefore, the variable is dropped to avoid problems when running the factor analysis test; KMO and Bartlett's test. The remaining 12 variables (CR3, CR4, AQ1, AQ3, AQ4, LR1, LR2, PR1, PR4, IE1, M1 and LE2) is chosen to be significant variables to be run in the factor analysis.

Factor Analysis

Factor analysis is a statistical method used to describe variability among observed, correlated variables in terms of a potentially lower number of unobserved variables called factors. Besides, factor analysis is used to identify underlying variables, or factors that explain the pattern of correlations within a set of variables observed. In other words, it is a method used in the identification of groups of variables. This technique is often used in data reduction to identify a small number of factors that explain most of the variance observed in a much large number of variables. In fact, factor analysis also can be used to generate hypotheses regarding causal mechanisms or to screen variables for subsequent analysis.

The correlation matrix shows all pairs of correlation coefficients for a set of variables. In SPSS, before finding a solution to a set of variables to make it more sensible, factor analysis is conducted in order to look at the intercorrelation between variables. Table 3 shows the R-matrix or correlation matrix produced using the coefficients option. This table contains the Pearson correlation coefficient between all pairs of selected variables. In order to do factor analysis, all selected variables should be correlated fairly well, but not perfectly. Any variables that do not correlate with any other variables should be eliminated from the study. Thus, this correlation matrix table can be used to check on the pattern of relationships among the variables.

Table 3. Correlation matrix (Pearson (n))

Variables	CR3	CR4	AQ1	AQ3	AQ4	LR1	LR2	PR1	PR4	IE1	M1	LE2
CR3	1	-0.74	0.75	0.33	0.02	-0.53	0.45	-0.35	0.03	-0.28	0.11	0.58
CR4	-0.74	1	-0.58	-0.18	-0.07	0.84	-0.38	0.23	-0.08	0.23	-0.10	-0.45
AQ1	0.75	-0.58	1	0.08	0.01	-0.59	0.58	-0.04	0.02	0.05	0.10	0.04
AQ3	0.33	-0.18	0.08	1	-0.08	-0.11	0.07	-0.01	-0.08	-0.13	-0.09	0.28
AQ4	0.02	-0.07	0.01	-0.08	1	0.02	-0.10	-0.25	0.99	-0.24	-0.12	0.06
LR1	-0.53	0.84	-0.59	-0.11	0.02	1	-0.67	0.06	0.10	0.04	-0.38	-0.10
LR2	0.45	-0.38	0.58	0.07	-0.09	-0.67	1	-0.12	-0.09	0.003	0.77	0.01
PR1	-0.35	0.23	-0.04	-0.01	-0.25	0.06	-0.12	1	-0.26	0.77	-0.25	-0.46
PR4	0.03	-0.07	0.02	-0.08	0.99	0.01	-0.10	-0.26	1	-0.23	-0.12	0.06
IE1	-0.28	0.23	0.05	-0.13	-0.24	0.04	0.003	0.77	-0.23	1	-0.01	-0.45
M1	0.11	-0.10	0.10	-0.09	-0.1	-0.38	0.77	-0.25	-0.12	-0.01	1	0.03
LE2	0.58	-0.45	0.04	0.28	0.07	-0.10	0.01	-0.46	0.06	-0.45	0.03	1

Based on Table 3, most of the variables show mediocre correlations among them. CR3 overall show a medium correlation with the other variables, except correlation between CR4 and AQ1, which shows a strong performance between them. CR4 shows high correlation with the one variable in liquidity group of variables (LR1) but a medium to low correlation with the others. AQ4 and PR1 show high correlation with one variable but medium correlation with other variable which with M1 and IE1 respectively.

Table 4 depicts the Kaiser–Meyer–Olkin (KMO) measure of sampling adequacy, and Bartlett's test of sphericity. The Kaiser-Meyer-Olkin Measure of Sampling Adequacy is a statistic that indicates the proportion of variance in your variables that might be caused by underlying factors. High values (close to 1.0) generally indicate that a factor analysis may be useful with the data. If the value is less than 0.50, the results of the factor analysis probably won't be very useful. According to Kaiser, any values more than 0.5 are barely acceptable and any values smaller than this should lead the researcher to either add more data or reconsider the selection of variables. Any values between 0.5 and 0.7 are considered as mediocre, values between 0.7 and 0.8 are considered as good, values between 0.8 and 0.9 are great, and values of more than 0.9 superb. For this data the value is 0.562, which falls into the mediocre range, so that it can be concluded the sample size is sufficient for factor analysis.

Meanwhile, Bartlett's test of sphericity tests the hypothesis that your correlation matrix is an identity matrix; each variable correlate perfectly itself ($r = 1$) but has no correlation with the other variables ($r = 0$), which would indicate that the variables are unrelated and therefore unsuitable for structure detection. Small values (less than 0.05) of the significance level indicate that a factor analysis may be useful with the data. The observed significance level is .0000 and this is small enough to reject the hypothesis. Table 4 shows a significant test shows that the correlation matrix is not an identity matrix, therefore, there is some relationship between the selected variables. Based on that, it can be concluded that the strength of the relationship among variables is strong and it is appropriate to proceed with factor analysis.

Table 4. KMO and Bartlett's Test

KMO and Bartlett's Test	
Kaiser-Meyer-Olkin measure of sampling adequacy	0.552
Bartlett's test of sphericity	
Approx. Chi square	1365.874
df	66
Sig.	< 0.0001

Table 5 shows the eigenvalues associated with each linear component or factor before extraction, after extraction, and after rotation. Before extraction, SPSS has identified 12 linear components or factors within the data set. The eigenvalues associated with each factor represent the variance explained by that particular linear component or factor. The SPSS output in Table 5 also shows the eigenvalue in terms of the percentage of variance explained: factor 1 explains 24.930% of the total variance, factor 2 explains 16.943% of the total variance, factor 3 explains 16.861% of the total variance and factor 4 explains 14.568% of the total variance. These 5 factors combined explain 73.302% of the total variance.

SPSS extracts all factors with eigenvalues > 1 and excludes factors with eigenvalues < 1 , thus leaving this study with 4 factors. The eigenvalues associated with these factors are again displayed, together with the percentage of variance explained, in the columns labelled extraction sum of squared loadings. The values in this part of the table are the same as the values before extraction, in the initial eigenvalues, except that the values for the discarded factors are ignored; hence, the table is blank after the third factor. In the Rotation Sums of Squared Loadings column, the eigenvalues of the factors after rotation are displayed.

Table 5. Total variance explained

Factor	Initial Eigenvalues			Extraction Sums of Squared Loadings			Rotation Sums of Squared Loadings		
	Total	% of Variance	Cumulative %	Total	% of Variance	Cumulative %	Total	% of Variance	Cumulative %
1	3.943	32.859	32.859	3.710	30.915	30.915	2.992	24.930	24.930
2	2.538	21.151	54.010	2.404	20.036	50.951	2.033	16.943	41.873
3	1.692	14.096	68.106	1.468	12.234	63.185	2.023	16.861	58.734
4	1.454	12.116	80.222	1.214	10.117	73.302	1.748	14.568	73.302
5	0.840	7.003	87.226						
6	0.609	5.079	92.304						
7	0.560	4.667	96.971						
8	0.202	1.682	98.653						
9	0.080	0.670	99.323						
10	0.054	0.451	99.775						
11	0.024	0.197	99.971						
12	0.003	0.029	100.000						

According to the results in Table 5, factor 1 accounted for considerably more variance than the other 3 factors (30.915% compared to 20.036%, 12.234% and 10.117%) before rotation but it accounts for only 24.930% of variance (compared to 16.943%, 16.861% and 14.568%, respectively) after the rotation.

Table 6. Factor score of coefficient matrix

	Factor			
	1	2	3	4
CR3	0.876	0.026	-0.203	0.290
CR4	-0.826	0.001	0.034	-0.311
AQ1	0.673	-0.205	0.215	0.283
AQ3	0.207	-0.006	-0.222	0.170
AQ4	0.101	0.835	0.525	0.043
LR1	-0.760	0.258	-0.247	-0.095
LR2	0.708	-0.408	0.352	-0.394
PR1	-0.443	-0.528	0.377	0.456
PR4	0.109	0.834	0.530	0.047
IE1	-0.342	-0.534	0.427	0.259
M1	0.393	-0.296	0.209	-0.691
LE2	0.444	0.290	-0.470	0.052

Based on the results from factor analysis in Table 6, the ratios with large loadings on the same factors are grouped. The first factor (F1) consists of one capital ratio (CR3), two asset quality ratios (AQ1 and AQ3), one leverage ratios (LE3). All the ratios grouped under this factor have positive loadings. Hence, an increase in the value of these ratios will lead to an increase in the factor score and thus to a lower failure risk of Islamic banks. The second factor (F2) consists of capital ratio (CR4), profitability ratio (PR1) and income-expenditure ratio (IE1). All of these ratios have positive loadings, thus the greater the value, the greater the financial strength of the Islamic bank, and the lower the risk of failure. The third factor (F3) consists of one asset quality ratio (AQ4), one liquidity ratio (LR1) and profitability ratio (PR4). The fourth factor (F4) consists of one liquidity ratio (LR2) and management ratio (M1). Both ratios grouped under this factor have positive loadings. This means that any increase in the value of these ratios will lead to an increase in the factor score, thus lowering the risk of Islamic bank failure.

Based on the component score of coefficient matrix in Table 6, factor scores for each Islamic bank are calculated for 10 years. Factor scores can be defined as a single score from an individual entity or sample representing performance on some latent variable. The score can be computed as follows.

$$F1 = 0.991(CR5) - 0.376(AQ1) - 0.077(AQ3) - 0.263(LE2)$$

and,

$$F2 = -0.046(CR6) + 0.582(PR1) + 0.211(IE1)$$

and,

$$F3 = -0.016(AQ4) + 0.036(LR3) + 1.015(PR5)$$

and,

$$F4 = 1.278(LR4) + 0.059(M2)$$

5.0 CONCLUSION

This study examines the credit risk exposure among Islamic banks in Malaysia by defining the factor groups of financial ratios that could indicate the financial distress occurrence of the banks. This paper use principal component analysis (PCA) and factor analysis on 20 financial ratios ranging from 2010 to 2019 of 10 Islamic banks in Malaysia

in order to identify the suitable ratio to measure financial distress of a bank. From the factor analysis, this paper would identify the financial healthiness of the Islamic banks in Malaysia and its possible sustainability against an economic downturn. This result is important for Malaysia as the hub of the Islamic financial market, with the majority of the population are Muslim. The strong credit risk management of the Islamic banks in Malaysia may strengthen the interest and confidence of the client on the Islamic financial market other than making Islamic banks better resilience against any financial shocks. At the end of research, the result showing that 12 financial ratios are significance to determine the financial distress of a bank. These financial ratios are further grouped into four factors which then strengthen the analysis of the study.

6.0 RECOMMENDATION

Future researchers are recommended to make a research on other variables differences with this study did that would be examined credit risk exposure among Islamic banks of the countries in Asia. Future researcher also recommended to do a comparison study of financial ratio between Islamic banks and conventional banks in Malaysia to study the differences of factor that could contribute to financial distress in Malaysia banking sector as a whole.

REFERENCES

- Abdul Karim, Y. F. (2014). Financial Distress And Performance Relationship Of Banks In Malaysia. *5th International Conference On Business And Economic Research (STHICBER 2014)*.
- Abdul Manab, N., Theng, N. Y., & Md Rus, R. (2015). The Determinants of Credit Risk in Malaysia. *Procedia - Social and Behavioral Sciences. Abdul Rahman, R. (2014). The Use Of "CAMELS" In Detecting Financial Distress Of Islamic Banks In Malaysia. The Journal of Applied Business Research, Volume 30, Number 2.*
- Abu Bakar, N. M., & Mohd Tahir, I. (2009). *Applying Multiple Linear Regression and Neural Network to Predict Bank Performance. International Business Research, Vol 2, No.4.*
- Abu Hussain, H., & Al-Ajmi, J. (2012). Risk management practices of conventional and Islamic banks in Bahrain. *Journal of Risk Finance, Vol. 13 No. 3, pp. 215-239.*
- Al-Eitan, G., & Khalid, T. B. (2019). *Credit Risk And Financial Performance Of The Jordanian Commercial Banks: A Panel Data Analysis. Academy of Accounting and Financial Studies Journal, 23(5):1-13.*
- Ariff, M., & Abubakar, S. Y. (1999). *The Malaysian Financial Crisis: Economic Impact ANd Recovery Prospects. The Developing Economies, XXXVII-4, 417-38.*
- Badrul Munir, M., & Bustamam, U. S. (2017). *CAMEL RATIO ON PROFITABILITY BANKING PERFORMANCE (MALAYSIA VERSUS INDONESIA). International Journal of Management, Innovation & Entrepreneurial Research, EISSN: 2395-7662, Vol. 3, No 1, April 2017, pg 30-39.*
- Brownbridge, M. (1998). *The Causes of Financial Distress in Local Banks in Africa and Implications For Prudential Policy.*
- Buckova, M. (2011). *The Role Of Banks In The World Of Finance.*
- Budiman, T., Herwany, A., & Kristanti, F. T. (2017). *An Evaluation of Financial Stress for Islamic Banks in Indonesia Using a Bankometer Model.*
- Cornett, M., McNutt, J. J., Strahan, P., & Tehranian, H. (2011). *Liquidity Risk Management and Credit Supply in The Financial Crisis. Journal of Financial Economics, 297-312.*
- Ekinci, R., & Poyraz, G. (2019). *The Effect of Credit Risk on Financial Performance of Deposit Banks In Turkey. 3rd World Conference on Technology, Innovation and Entrepreneurship (WOCTINE), 979-987.*
- El-Bannany, M. (2015). *Global Financial Crisis and Credit Risk Disclosure in The UAE Banks. Risk governance & control: financial markets & institutions, Volume 5, Issue 1.*
- Ferri, G., Hahm, H., & Bongini, P. (1998). *Corporate Bankruptcy in Korea: Only the Strong Survive. World Bank Report.*
- Gebreslassie, E. (2015). *Determinants of Financial Distress Conditions of Commercial Banks in Ethiopia A Case study of Selected Private Commercial Banks. Journal of Poverty, Investment and Development, Vol.13.*
- Magd, H., & McCoy, M. (2014). *Islamic Finance Development in the Sultanate of Oman: Barriers and Recommendations. Procedia Economics and Finance 15, 1619 – 1631.*
- Misman, F. N., & Bhatti, M. I. (2010). *RISKS EXPOSURE IN ISLAMIC BANKS: A CASE STUDY OF BANK ISLAM MALAYSIA BERHAD (BIMB).*
- Ngunjiri, N. (2016). *The Causes Of Financial Distress In Kenya.*
- Nurul Husna, H., & Abdul Rahman, R. (2012). *Financial Distress–Detection Model for Islamic Banks. International Journal of Trade Economics and Finance, Vol. 3, No. 3.*
- Othman, J. (2013). *Analysing Financial Distress in Malaysian Islamic Banks: Exploring Integrative Predictive Methods. Durham theses, Durham University.*
- Ramadhan, M., & Naseeb, A. (2015). *The Global Financial Crisis: Causes and Solutions.*
- Safaei, Z., Safari, M., & Farahmand, H. (2014). *Factors Affecting Credit Risks of Malaysian Financial Institutions Post 2008-2009 Financial Crisis. International Journal of Managerial Studies and Research, Volume 2, Issue 10, Page No: 64-73.*
- Safiullah, M. (2010). *Superiority of Conventional Banks & Islamic Banks of Bangladesh: A Comparative Study. International Journal of Economics and Finance, Vol. 2, No. 3.*
- Uda, N. A., Hamid, M. A., & Janor, H. (2018). *Determinants of Credit Risk in Islamic and Conventional Bank: Evidence from Malaysia. International Journal of Academic Research in Business and Social Sciences, 8(6), 1054-1068.*
- Vodova, P. (2003). *CREDIT RISK AS A CAUSE OF BANKING CRISES.*

WHY DO SOME MUSLIM PURCHASE OR NOT TO PURCHASE IN A SHARIAH-BASED PRIVATE RETIREMENT SCHEME (PRS)?

Umami Syafiqah Nor Azman and Siti Hajar Salwa Ahmad Musadik

Islamic Business School, Universiti Utara Malaysia

Abstract

Shariah-based Private Retirement Scheme (PRS) is not a new asset in Malaysia. Established since 2012 as voluntary retirement scheme in assisting the existing mandatory Employment Provident Fund (EPF) should be an eye-catching factor for the private sector employee to save and invest with shariah-based PRS as an extra protection approaching their retirement phase. But somehow, the numbers of members investing in shariah-based PRS still lack behind compared to the conventional PRS members though it continuously in collecting the returns for their members through Islamic investment. Hence, this study aimed to identify the correlation between religiosity, Islamic financial literacy, propensity to plan and rate of return. By using 130 respondents from air transportation sector at Lapangan Terbang Sultan Abdul Halim (LTAH) Kedah and employing quantitative approach, this study suggests that Islamic financial literacy, propensity to plan and rate of return significantly influence the intention to purchase shariah-based PRS. However, religiosity suggested otherwise. Though Muslims perceived the Islamic principle as commitment in investment-related decision making, many researchers also stay uncertain about its significance in clarifying customer choices. Investing in instrument like Shariah-based PRS is not tiresome but with the proper knowledge and plan, Muslims are able to make right decision-making related to the daily financial activity particularly investing the retirement scheme according to Shariah.

Keywords: Shariah-based Private Retirement Scheme, Religiosity, Islamic Financial Literacy, Propensity to Plan, Rate of Return

1.0 INTRODUCTION

Preparation for retirement planning is part of the main reason for social security institution to adhere to the social protection during the advanced years of its members. Retirement planning is important because it will ensure a comfortable life during retirement (Zaihan & Noar, 2017). Late retirement planning will cause retiree in dilemma thereafter due to the lack of steady financial income and will bring negative impact to their life (Yahaya, Ibrahim, Zulkafli & Razimi, 2017).

PRS comes into existence in Malaysia to cater the inadequacy of retiree's savings aside from government pension scheme and mandatory saving of the Employees Provident Fund (EPF), since both of these instruments are not sufficient enough to fund the retirees (Zabri, Ahmad and Lian, 2016). PRS was introduced into the market in 2012 to enhance voluntary long-term savings and investment scheme in order for the retiree to save more for their retirement with the objective to enhance the living standards for Malaysians during their retirement through additional savings (Private Pension Administration [PPA], 2019c).

Above all, not many aware the existence of Shariah-based PRS (Zabri et al., 2016) causing the purchase intention of Shariah-based PRS is less known especially among Muslims (Yahaya et al., 2017). However according to Gomes (2019), the number of PRS members has been expanded. Claimed as record-breaking number of members in 2019 report, this industry continued to grow and provide steady, yet profitable returns to its members.

Referring to Security Commission (2020), in financial year (FY) 2019 showing that only 2.495b of unit circulating under Shariah-compliant fund while conventional fund is 5.374b units. The total net asset value (NAV) of Shariah fund is only MYR 1.054b which is much lower than the conventional which is MYR 2.420b. According to Chee (2019), there is no specific indication that returns of Shariah-compliant funds that are higher or lower than conventional funds in Malaysia. Despite many efforts of policy makers to introduce Shariah-based PRS to Malaysian, many scholars such as Hussain et al. (2018); Ali et al. (2017); Yahaya & Ibrahim (2017) and Zabri et al. (2016) still found that there was lack of awareness among Malaysians to purchase Shariah-based PRS. This is contradictory to the report by Gomes (2019) and The Star (2019) saying that the number of PRS industry sees record-

breaking number of members due to the high demand of Shariah-compliant products that generally offers more stable and consistent returns over time. Nonetheless, the awareness to purchase Shariah-based PRS is still lacking compared to conventional PRS. Meanwhile, Shariah-based PRS recorded the number of 86,749 individual investors while conventional PRS is having 164,680 individual investors. It is obvious that the numbers of individuals subscribing to Shariah-based PRS is less than half the number of conventional PRS subscribers. In an article by Gomes (2019) in *The Edge Market* newspaper, he reported that there are growing numbers of PRS participant by 38% out of more than 455,000 members served nationwide with the industry worth than MYR 3.5 billion where in Chee (2020) proved that Malaysian becoming more conscious in retirement saving but they still lack awareness to purchase Shariah-based PRS.

Therefore, in this context of study, it is important to identify the intention to purchase Shariah-based private retirement scheme among Muslims especially in the private sector as PRS should be appealing to private sector employee as EPF saving will be depleted over time once the person retire (Rao, 2019). Hence, the study aimed to determine if religiosity, Islamic financial literacy, propensity to plan and rate of return correlated with the intention to purchase Shariah-based PRS.

2.0 LITERATURE REVIEW

Purchase Intention

Behavioral intention is generally portrayed as ability to embrace, utilize or acknowledge a demonstration of conduct (Fishbein & Ajzen, 1975). Intention is considered as prominent predictor of an actual behavior (Lajuni et al., 2017). Meanwhile, Ajzen & Madden (1986) found that the vigorous an individual's intention, the more probable they are eager and expected to attempt and consequently the more prominent the probability that the conduct will in the end be performed. Thus, intention is considered as precursor and best predictor of behavior according to Ajzen (2002) as it effortlessly explaining cognitive process to comprehend consumer decision making process (Han & Kim, 2010).

To date, not many in-depth studies was done regarding the reasons why Malaysian intended to choose PRS as a part of their retirement fund. Some researchers argued the reason why peoples chose this plan is because of the tax incentives up to MYR 3000 (Hussain et al., 2018). Even though many argue on its performance saying that the PRS funds are struggling to hit the benchmark (Hussain et al., 2018), there are also articles from Chee (2019); myPF (2018) and PPA (2020a) claiming that PRS is performing well in the capital market despite of the economic fluctuation.

In fact, there are two studies from Yahaya & Ibrahim (2017) and Yahaya et al. (2017) discussing the factor of why Shariah-based PRS are chose to be part of retirement planning, but the studies only revolved around the demographic factor and Theory of Planned Behavior (Ajzen, 1991) by using the university students as respondents. However, a study by Zabri et al. (2016) was a little different because this study used respondents from industry. From the findings, the awareness among the private sector employee is still low (Zabri et al., 2016) where the data is based on the observation of research for the year 2016 and years before that. Meanwhile, the rest of articles found in the search engine only about legal analysis regarding PRS perception. Thus, this study attempt to find another new unknown factor that could be the factor why the numbers of Shariah-based PRS expanded throughout the years. The variables such as religiosity factor, Islamic financial literacy, propensity to plan and rate of return are chose to be independent variables for this study.

Religiosity

Islam is a comprehensive religion that covers every aspect in human life. As Muslims, we took care of religious matters seriously, as it involved the matters of faith and values. Religion could affect how an individual comes up with his desire in life and what he regards as his responsibilities to himself, others and his God (Mansori, Sambasivan, & Md-Sidin, 2015). Though economy and finance are always perceived as business discipline that are far removed from spirituality and religion (Alderman, Forsyth, & Walton, 2017), many studies have proven that religiosity could affect the direction, intensity and consumption towards attitude and feeling of a range of products in the market (Basri & Kurniawati, 2019; Kusumawardhini, Hati, & Daryanti, 2016; Soma, Primiana, Wiryono, & Febrian, 2017). Religiosity defined as "the degree to which a person uses or adheres to his or her religious values, beliefs and practices and uses them in daily living" (Worthington et al., 2003). The behavioral patterns of the followers and correlation between religiosity and values are consistently prominent across monotheistic religions (Mansori et al., 2015). Religiosity has long connected the history with financial decision making business leaders and investors awareness of how their own religiously inspired biases and preferences (Alderman et al., 2017). Using

internal and external dimensions, it will be able to influence people cognitively and behaviorally (Basri & Kurniawati, 2019). Religiosity in Islamic finance was deemed as an unique factor that will be able to differentiate the criteria selection of Islamic financial products from the conventional counterparts (Zainudin, Mahdzan, Hashim, & Sulaiman, 2019). The more vigorous the religious commitment, the larger desire for Islamic product and services (Soma et al., 2017). According to Brekke (2018) Islamic economics, finance and banking had appeared as an important indicator of personal piety and religious identity over the past decade. Meanwhile, Price Waterhouse Coopers [PWC] (2009) in their report wrote that the creation of Shariah-compliant investment product is mainly because of the individuals are attracted by the idea of faith-based investment. Tahir & Brimble (2011) too agreed and indicated that during wealth-maximizing phase of Islamic investment among Muslims, religiosity played a huge role in determining asset allocation. Jamaludin et al. (2012) also found that Muslims perceived the commitment to Islamic principles as the utmost important criteria in selecting an investment fund. In the case of Islamic investment, since Shariah-based PRS is part of investment instrument in Islamic finance with the underlying retirement purpose, it is important to consider Shariah-compliant status before purchasing the scheme because religiosity should be placed above profit motive.

Financial Literacy

Financial literacy is defined by Abdullah & Anderson (2015) as the process of understanding financial concepts and products among consumers and investors while possessing the confidence to make their own choice and brave enough to improve their own financial well-being. OECD (2016) aligned that financial literacy is consisted of components of financial knowledge, financial behavior and financial attitude but indicating that financial education is the most in need which the theorem also in agreement with Tuominen & Thompson (2015) work. The financial knowledge is what makes financial decision-making constitutes financial literacy where it contained the element of 'understanding' and 'use' (Huston, 2010). Meanwhile, financial behavior is regarded as "the way in which a person behaves will have a significant impact on their financial wellbeing" (OECD, 2013). While financial attitude according to Rai, Dua, & Yadav (2019) is "personal inclination towards financial matters" but OECD (2016) implies that attitude should influence human decision to act or not to act according to their belief. However, in understanding Islamic financial literacy, it is important to note that it was constructed from three components exactly like the concept of basic financial literacy. From the Islamic perspective, Islamic financial literacy is deemed as tools to improve financial behavior according to Shariah guidelines (Nawi et al., 2018) because being literate in finance will allow us to identify what is right and what is wrong. Since its inception, only a few researchers such as Abdullah & Anderson (2015) and Abdullah, Wahab, Sabar, & Abu (2017) defined the definition of Islamic financial literacy from the context of their study. Abdullah & Anderson (2015) defined Islamic financial literacy as "the knowledge gained through education and/or specific experience relating to important concepts and products of Islamic finance" while Abdullah et al. (2017) defined Islamic financial literacy as "ability to understand finance based on the Shariah compliance." Nonetheless, Abdullah & Anderson (2015) and Abdullah et al. (2017) is the same author that deduced the definition making with no raised objections from the fellow researches such as Nawi et al. (2018); Rahman, Tajudin, Fadzli, & Tajuddin (2018) and Setiawati et al. (2018) regarding his proposed definition. Nevertheless, choosing the right plan of retirement is important and by having adequate Islamic financial literacy would allow us to single handedly pick the right investment product that is able to give good return yet allow us to stay true to our faith. Having high level of Islamic financial literacy will allow us to make a better investment decisions because Shariah-based PRS scheme is related to individual's financial welfare (Khan, Tan, & Gan, 2019). Zaman, Mehmood, Aftab, Shahid, & Ameen (2017) are also in agreement that Islamic financial literacy is an important indicator for an adoption of Islamic banking because if we turn our attention to Shariah-based PRS, it is also part of bank's investment instrument in certain banks who also happened to be a PRS provider. Thus, being a Muslim equipped with a high level Islamic financial literacy, it will perhaps help them gaining capability to understand the concept of Islamic finance and infuse good financial behavior guided by Shariah, in order to purchase the right Shariah-based PRS scheme which will result in prudent and wise financial decisions (Nawi et al., 2018).

Propensity to Plan

Propensity to plan is a kind of relatively new topic among academician. It had been theoretically established by Ameriks et al. (2003) and reinforced by Lynch, Netemeyer, Spiller, & Zammit (2010) who came out with the proper measurement. propensity to plan is defined as "consumer's tendency to plan for long-term goals that may result in rational goal-setting behavior" (Ameriks et al., 2003). The study regarding propensity to plan begin by Ameriks et al. (2003) who found that there were inconsistency of the household with similar salary but possessed different wealth accumulation in America. Propensity to plan is a skill possessed by an individual where the individuals with high propensity to plan will be a rational, patient, good at risk-taking, budgeting, control spending, and saving frequently (Xiao & O'Neill, 2018). Therefore, it was said that when the level of propensity to plan increases, both the retirement savings and net worth will increased (Lee & Kim, 2016). This is because the planners are able to

have a better control of their spending and may achieve their goal of wealth accumulation (Ameriks et al., 2003). This is owing to the fact that propensity to plan is a comprehensive and voluntary response or willingness to make a better financial decisions in the form of behavioral effort and implementation upon asset accumulation (Lee & Kim, 2016). Propensity to plan is capable to clarify the different levels of asset accumulation based on different levels of management efforts in savings (Ameriks et al., 2003). Lee & Kim (2016) indicate that propensity to plan played a huge role as an indicator of success upon financial decision making of an individual where an individual with high propensity to plan will come out with investing decisions or making saving that tend to invest more assets in retirement accounts and accumulating more wealth. Conversely, good financial practices relate to financial planning such as saving and investing would help individuals achieving a good financial well-being (Huston, 2010). Ali, Rahman, & Bakar (2015) too has indicated that financial planning is important to ensure financial satisfaction and financial well-being in the long term and it can be done through common activities such as saving for emergencies and retirement. According to Lee et al. (2019), propensity to plan is an important driver to improve the relationship between objective of financial plan and financial well-being and will effect significantly on wealth accumulation if a certain level of behavioral discipline is applied together with financial plan. Apparently, propensity to plan can be explored using either time versus money where individual differences for time will extend to money or long run versus short run concept where implicating the differences of consumers preferences in their short-run planning or long-run planning mainly due to the specificity of the planning itself (Lynch et al., 2010). In the case of Shariah-based PRS, it can be used as a strategy to attain goal of financial well-being. As Shariah-based PRS is a voluntary long-run saving for retirement and doubled with preference in selection of fund investment based on the appetite of the investor, hence, it will be a great tool to enhance the financial well-being of investor upon approaching the retirement phase.

Rate of Return

General definition of return is the benefit that associated with investment, however, the real definition of rate of return is defined as “percentage increase in returns associated with the holding period” (Levisauskaite, 2010). Meanwhile, investment is defined as “the current commitment of dollars for a period of time in order to derive future payments that will compensate the investor for the time the funds are committed, the expected rate of inflation, and the uncertainty of the future payments” (Reilly & Brown, 2012). In most investment, the measurable return consists two components, which are capital gain or loss of income. Precisely, the investor wants to gain the rate of return that can pay them back over time, when there are expected rate of inflation and during the uncertainty of the return prevails (Reilly & Brown, 2012). Islamic investment is much more complex than conventional counterpart. Islamic investment area is still largely unknown but the most obvious regarding this area is, it used extra financial parameters. Discussing extra parameter, Islamic investment must strictly follow the Shariah guidelines and not mixed with element that is prohibited in Islam. Nonetheless, the rate of return is supposed to be an eye-catching factor to be included in retirement planning, though in Islam, we should not focus on maximization of return yet we must live in moderation according to Shariah but preparation for contingency moment is encouraged in Islam. Nevertheless, the performance of Malaysian Shariah-based PRS deserved well applause despite the economic uncertainties that is happening currently. myPF (2018) claimed that Shariah-based PRS fund is steadily catching up non-Islamic funds because the Islamic finance and industrial is outperforming. This is agreed by (Chee, 2019) who contends that over-time Shariah-compliant funds also provides competitive returns over conventional funds. The PRS provider such as Affin Hwang Aiman PRS Shariah Growth, AmPRS PRS Islamic Fixed Income and Kenanga Shariah One PRS Equity are top-tier player for Islamic fund in financial year 2019/2020 as they were assessed by Lipper Leader ratings from three aspects which are total returns, consistency, and preservation (myPF, 2020).

For 2019, Islamic funds continue to catch up non-Islamic funds' performance although still slightly lagging behind. Though, Islamic finance and industrials sectors are outperforming, according to Chee (2019), there is no specific indicator that returns of Shariah-compliant funds are higher or lower than conventional funds in Malaysia. Nonetheless, it is good to see another Islamic fund outperforming most of its peers. Despite the volatility of the current economy, the expected return should be good enough for long-term period as the Shariah-based PRS is mainly served for retirement purpose.

It is important to test this variable once again towards the intention to purchase Shariah-based PRS because the ultimate objective for investor is to achieve the best possible returns for their investments (Chee, 2019). Although investing in funds with the highest returns is not necessarily a right decision, yet investing in a fund with a lower return also may not be necessarily a wrong decision, but investing in funds that can produce a certain level of returns give the certain level of risk that we are willing to assume (Mohamed, 2017). This is in line with Rabia & Naqvi (2018) and Selvanathan et al. (2018) studies saying that the rate of return with psychology have significant impact

on behavior. Hence, Muslim investors asked to be aligned with Shariah directive despite being motivated by profit maximization (Imad, 2017).

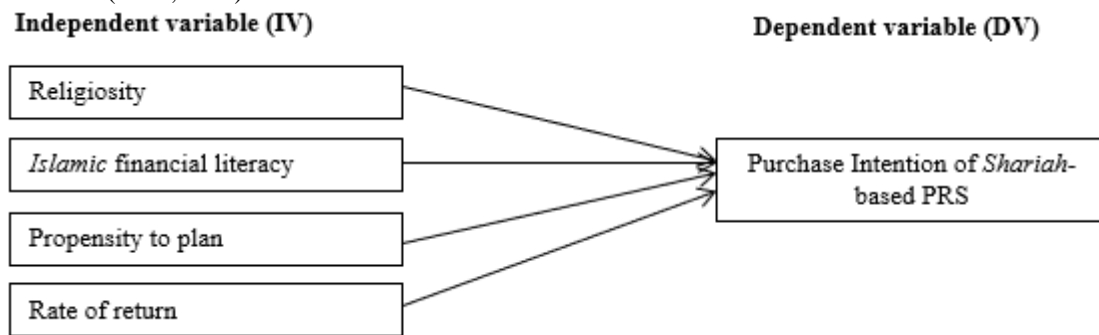

H₀₁: There is no correlation between religiosity and the intention to purchase Shariah-based PRS among air transportation employees

H₀₂: There is no correlation between Islamic financial literacy and the intention to purchase Shariah-based PRS among air transportation employees

H₀₃: There is no correlation between propensity to plan and the intention to purchase Shariah-based PRS among air transportation employees

H₀₄: There is no correlation between rate of return and the intention to purchase Shariah-based PRS among air transportation employees

3.0 METHODOLOGY

The study used quantitative method using the data collection from real-time collection to observe the result of the study. The primary data was collected through cross-sectional personal administered questionnaire as the data collection tool via Google survey. The interpretation of the results in quantitative data analysis used the Statistical Package for the Social Sciences (SPSS software version 25.0). Interval data was used in the form of close-ended questions and asked in 5-points Likert scale questions (1 = strongly disagree; 5 = strongly agree). The unit of analysis for this study is the adult employees within the age range of 20 to 55 that working in air transportation sector at Lapangan Terbang Sultan Abdul Halim (LTSAH) (IATA=AOR). By using population of 202 individuals, simple random sampling was used as the data collection technique due to the complete list of the staff involved cannot be released to the public due to the private and confidential clauses by Personal Data Protection Act (Act 709) making the systematic random sampling cannot be proceeded.

Meanwhile, the respondent was chosen mainly due to the abilities to stimulate the investment and economic development (International Air Transport Association [IATA], 2019) while generating US \$10.3 billion which is 3.5% percent to the Malaysia Gross Domestic Product (GDP) in 2018 (IATA, 2019). Air transportation sector in Malaysia also has been supporting 450,000 jobs through airlines services and tourism (IATA, 2019) and having output multiplier of 2.1 meaning to say every RM1 output produced by the aviation sector leads to 2.1 times increase in the output for the whole economy (Malaysian Aviation Commission [MAVCOM], 2017).

Aforementioned to multiplier effect, International Civil Aviation Organization [ICAO] (2019) also agreed that air transportation sector has been contributing to the economy greatly by leaving direct impact, indirect impact, induced impact and catalytic impact. Aviation industry has been regarded as sources of considerable economy, creating jobs, generating economic activity around aviation industry such as aviation fuel suppliers, construction companies that build airport facilities, suppliers of subcomponents used for aircraft, shop retailers, a range of service industries, networking and many more (ICAO, 2019).

4.0 DATA ANALYSIS

4.1 Respondent profile

Table 1. The profile of the respondents

		Frequency	%	Min	Max	Mean	Var	Std Variation
Gender	Female	68	52.3	1	2	1.48	0.251	0.501
	Male	62	47.7					
	Total	130	100.0					
Age	20-25	21	16.2	1	7	2.70	2.258	1.503
	26-30	58	44.6					
	31-35	22	16.9					
	36-40	11	8.5					
	41-45	8	6.2					
	46-50	6	4.6					
	51-55	4	3.1					
	Total	130	100.0					
Race	Malay	128	98.5	1	4	1.05	0.137	0.371
	Others	2	1.5					
	Total	130	100.0					
Education	SPM	38	29.2	1	6	2.81	1.769	1.330
	Foundation / Matriculation / STPM / A-Level	7	5.4					
	Diploma	34	26.2					
	Bachelor Degree	45	34.6					
	Masters	5	3.8					
	Ph.D	1	0.8					
	Total	130	100.0					
Employment Status	Permanent	108	83.1	1	3	1.18	0.183	0.427
	Contract	20	15.4					
	Temporary	2	1.5					
	Total	130	100.0					
Marriage Status	Single	66	50.8	1	3	1.51	0.283	0.532
	Married	62	47.7					
	Divorced	2	1.5					
	Total	130	100.0					
Monthly income	Less than 2000	55	42.3	1	5	1.72	0.667	0.817
	2001 - 4000	64	49.2					
	4001 - 6000	6	4.6					
	6001 - 8000	2	1.5					
	8001 - 10000	3	2.3					
	Total	130	100.0					
Position	Non - executive	101	77.7	1	4	1.39	0.643	0.802
	Supervisor	11	8.5					
	Executive	14	10.8					
	Manager	4	3.1					
	Total	130	100.0					

4.2 Pearson-Correlation Test

Table 2. Correlation result between religiosity and purchase intention of Shariah-based PRS

Correlations		PRS	REL	IFL	PTP	ROR
PRS	Pearson Correlation	1	.068	.352**	.217*	.259**
	Sig. (2-tailed)		.445	.000	.013	.003
	N	130	130	130	130	130
REL	Pearson Correlation	.068	1	.390**	.353**	.308**
	Sig. (2-tailed)	.445		.000	.000	.000
	N	130	130	130	130	130
IFL	Pearson Correlation	.352**	.390**	1	.539**	.629**
	Sig. (2-tailed)	.000	.000		.000	.000
	N	130	130	130	130	130
PTP	Pearson Correlation	.217*	.353**	.539**	1	.483**
	Sig. (2-tailed)	.013	.000	.000		.000
	N	130	130	130	130	130
ROR	Pearson Correlation	.259**	.308**	.629**	.483**	1
	Sig. (2-tailed)	.003	.000	.000	.000	
	N	130	130	130	130	130

** . Correlation is significant at the 0.01 level (2-tailed).

* . Correlation is significant at the 0.05 level (2-tailed).

Based on Table 2, independent variables which are Islamic financial literacy, propensity to plan and the rate of return have a correlation with the purchase intention of Shariah-based PRS among air transportation employees. However, independent variable for religiosity has suggesting insignificant correlation with the the purchase intention of Shariah-based PRS among air transportation employees.

The study found that religiosity was not correlated with the intention to purchase Shariah-based PRS at $r = 0.068$, $p = 0.05$. In spite of the fact that religiosity is constantly considered as a key factor in the decision of a bank for Muslims, researchers stay uncertain about its significance in clarifying customer choices (Rani, 2015). The result was significant with similar studies by Basri & Kurniawati (2019) and Rani (2015) that found religiosity has an indirect effect on purchase intentions of Islamic bank services.

In the second objective, through the Islamic financial literacy variable, it was found that it is moderately and positively correlated ($r = 0.352$, $p = 0.05$). The result is also consistent with Abdullah & Razak (2016); Rahman et al. (2018) and Zaman et al. (2017) indicating that the Islamic financial literacy would also help consumers to recognize and appreciate the unique features and characteristics of Islamic finance and its true economic value. Sabri (2016) also supported that with adequate financial literacy, individuals armed with advanced financial literacy are more prepared to take risk and chances when making investment decisions.

For this objective, it was found that propensity to plan has a significant positive ($r = 0.217$, $p = 0.05$). The finding is supported by Kimiyagahlam, Safari, & Mansori (2019); Lee & Kim (2016) and O'Neill et al. (2016) that propensity to plan is able to affect pension plans and net worth in the form of retirement planning and financial behavior. According to Xiao & O'Neill (2018) the propensity to plan made specific contributions to financial satisfaction the following regulation of socio-economic and other financial capacity factors.

Lastly, in this objective, the rate of return too has proven to have a significant positive ($r = 0.259$, $p = 0.05$). The finding is supported by Habib & Masih (2017) and Haron & Ahmad (2000) indicating that Islamic banking system customers are similar in behavior when choosing their investments from the aspect of Islamicity and are driven by profit motives. In addition, Arshad & Nurfadilah (2017) stated that the rate of return also has a positive relationship with the customer when choosing to deposit at Islamic bank. When it comes to the rate of return, Islamic stocks are an option that is practical and ethical at the same time for Muslim investors to invest their capital according to their religious beliefs without sacrificing the financial performance (Abbes, 2012).

5.0 CONCLUSION

To sum up, this research was carried out to find a relationship between the determinants influencing the intention to buy Shariah-based PRS among air transportation employees in Kedah. From the study, it was found that Islamic financial literacy, propensity to plan and the rate of return are correlated with the purchase intention of Shariah-based PRS among air transportation employees. Meanwhile, religiosity is not correlated with the purchase intention of Shariah-based PRS among air transportation employees. This finding also suggests some guidance for Islamic banking institutions to develop strategies to attract more consumers to buy Shariah-based PRS and could also improve Muslims' perceptions on this topic themselves. This study concludes that religiosity factors did not function as the main role to influence Muslims to purchase PRS and they tend to concern about the rate of return of the scheme which possibly guarantees their long term planning.

6.0 RECOMMENDATION

This study is suggesting the essential and important implications to bank management which simultaneously act as PRS provider and government. The management teams need to improve and enhance the promotion strategies to all level of individuals not only to the top bracket of the community effectively and efficiently in order to attract the customer selection to choose Shariah-based PRS. But, this is important because many studies reported that the awareness of the scheme is relatively low and only affecting the top bracket of community to invest in the scheme causing the penetration level of Shariah-based PRS is relatively low compared to conventional counterparts. Hence, PRS provider is encouraged to have a greater emphasis on raising awareness among clients regarding the Shariah-based PRS products.

In addition, PRS Providers also need to ensure that the employees in-charged are also equipped with adequate knowledge or, at least, the fundamental of Islamic finance and banking in order to give clear understanding to the customers. This is important for educating people so they can better understand their knowledge from the instilled awareness about Islamic retirement planning and Islamic investment. The community will also gain information from Shariah perspectives relating to current economic issues.

The researcher also suggested that, if the study managed to be done at a bigger station, perhaps the result might be different because most of the employees at the bigger station consist of high educated executive employees. Besides, in the airlines industry the most valuable asset of a company is the air-crew and the technical crew apart from the physical asset like the aircraft, buildings and etc. Hence, these employees were getting reimbursed differently from the rest of the non-asset employees due to long-hours of working. Perhaps they are having different perspective regarding these voluntaries saving scheme due to the high financial capabilities and high level of education. Therefore, future researcher is recommended to overcome this limitation by increasing the sample size from other category of consumers from different parts of the country.

Last but not least, this study also gives the benefit to the policy makers in providing the new policies and strategies. It can also be taken by the government and other industry practitioners in response to a favorable or unfavorable trend in Shariah-based PRS determinants to ensure the stability and sustainability, particularly through Islamic investment. All the pre-exist policies is suggested to be enhanced and improvised for instance, by extending the period of tax exclusion incentives up to MYR 3000 or revamped the one-off government top-up to a new alluring rate to attract new investors investing in this product. Therefore, the goodness and the benefit of these scheme could be long-lasting and at the same time gained and shared within Muslims in order to achieve *Falah* worldly and in Hereafter.

ACKNOWLEDGEMENTS

The researcher would like to thank you to Jabatan Tenaga Kerja Negeri Kedah (JTK) and Malaysia Airport Holding Berhad (MAHB) for their willingness and cooperation in providing the access for collecting the data.

REFERENCES

- Abbes, M. B. (2012). Risk and return of islamic and conventional indices. *International Journal of Euro-Mediterranean Studies*, 5(1), 1–23. <https://doi.org/10.1007/s40321-012-0001-9>
- Abdullah, H. R., & Abdul Razak, A. L. H. (2016). Exploratory Research Into Islamic Financial Literacy In Brunei Darussalam. In A. G. Ismail & K. Mohamed Ali (Eds.), *UNISSA Press* (1st ed., pp. 59–83). Gadong, Brunei Darussalam: UNISSA Press.
- Abdullah, Mohamad A, Wahab, S. N. A. A., Sabar, S., & Abu, F. (2017). Factors Determining Islamic Financial Literacy Among Undergraduates. *Journal of Emerging Economies & Islamic Research*, 5(2), 67–76.
- Abdullah, Mohamad Azmi, & Anderson, A. (2015). Journal of Emerging Economies and Islamic Research Islamic Financial Literacy among Bankers in Kuala Lumpur. *Journal of Emerging Economies and Islamic Research*, Vol. 3, No(2010). Retrieved from www.jeeir.com
- Ahmad Sabri, N. A. (2016). The Relationship between the Level of Financial Literacy and Investment Decision-Making Millennials in Malaysia. *Taylor's Business Review A Contemporary Business Journal*, 6(August), 39–47.
- Ajzen, I. (1991). The Theory of Planned Behavior. *ORGANIZATIONAL BEHAVIOR AND HUMAN DECISION PROCESSES*, 50, 179–211.
- Ajzen, I. (2002). Behavioral Interventions Based on the Theory of Planned Behavior. *Research Policy*, 2011, 1–6. <https://doi.org/10.1016/j.respol.2007.07.006>
- Ajzen, I., & Madden, T. J. (1986). Prediction of goal-directed behavior: Attitudes, intentions, and perceived behavioral control. *Journal of Experimental Social Psychology*, 22(5), 453–474. [https://doi.org/10.1016/0022-1031\(86\)90045-4](https://doi.org/10.1016/0022-1031(86)90045-4)
- Alderman, J., Forsyth, J., & Walton, R. (2017). How religious beliefs influence financial decision-making: Implications for business leaders. *Graziadio Business Report*, 20(3), 1–10.
- Ali, A., Rahman, M. S. A., & Bakar, A. (2015). Financial Satisfaction and the Influence of Financial Literacy in Malaysia. *Social Indicators Research*, 120(1), 137–156. <https://doi.org/10.1007/s11205-014-0583-0>
- Ameriks, J., Caplin, A., & Leahy, J. (2003). Wealth accumulation and the propensity to plan. *Quarterly Journal of Economics*, 118(3), 1007–1047. <https://doi.org/10.1162/00335530360698487>
- Basri, Y. Z., & Kurniawati, F. (2019). Effect of Religiosity and Halal Awareness on Purchase Intention Moderated by Halal Certification. *KnE Social Sciences*, 2019, 592–607. <https://doi.org/10.18502/kss.v3i26.5403>
- Brekke, T. (2018). Halal money: Financial inclusion and demand for islamic banking in Norway. *Research and Politics*, 5(1). <https://doi.org/10.1177/2053168018757624>
- Che Arshad, N., & Nurfadilah, D. (2017). The Factors Influencing the Changes of Deposit in Islamic Bank: Comparative Study between Malaysia And Indonesia. *Journal of Islamic Banking and Finance*, 5(2), 37–46. <https://doi.org/10.15640/jibf.v5n2a6>
- Chee, J. (2019). Shariah vs conventional : Which funds are better? Retrieved February 28, 2020, from Maybank Asset Management International Financial Centre website: <https://www.maybank-am.com/documents/15019/0/syariahconventional.pdf?2982f15-335b-4080-8711-ba0291cbee6>
- Chee, J. (2020, February 28). Is the PRS worth investing in? *Focus Malaysia*. Retrieved from <https://focusmalaysia.my/mainstream/is-the-prs-worth-investing-in/>
- Fishbein, M., & Ajzen, I. (1975). Belief, Attitude, Intention and Behavior: An Introduction to Theory and Research. *Contemporary Sociology*, 6(2), 244. <https://doi.org/10.2307/2065853>
- Gomes, V. (2019, June 25). Retirement: Lower returns for PRS funds in 2018. *The Edge Malaysia*. Retrieved from <https://www.theedgemarkets.com/article/retirement-lower-returns-prs-funds-2018>
- Habib, F., & Masih, M. (2017). The effect of interest rates and rate of profit on islamic investment deposits: evidence from Malaysia. *Munich Personal RePEc Archive*.
- Han, H., & Kim, Y. (2010). An investigation of green hotel customers' decision formation: Developing an extended model of the theory of planned behavior. *International Journal of Hospitality Management*, 29(4), 659–668. <https://doi.org/10.1016/j.ijhm.2010.01.001>
- Haron, S., & Ahmad, N. (2000). The effects of conventional interest rates and rate of profit on funds deposited with Islamic banking system in Malaysia. *International Journal of Islamic Financial Services*, 1(4), 1–7.
- Hussain, H. I., Shamsudin, M. F., Alaeddin, O., Razak, A., Hadi, A., & Effuandy, N. (2018). Analysing Shari' ah Compliant Retirement Planning : the Case of Malaysia. *International Journal of Engineering & Technology*, 7, 106–111.

- Huston, S. J. (2010). Measuring Financial Literacy. *The Journal of Consumer Affairs*, 44(2), 296–316.
- Imad, O. M. (2017). *WHY DO WE INVEST ISLAMICALLY ? A LITERATURE*. 1(6), 1–16.
- International Air Transport Association. (2019). *The Importance of Air Transport to Malaysia*. Montreal, Canada.
- International Civil Aviation Organization. (2019). *Aviation Benefits Report 2019*. Montreal, Canada.
- Jamaludin, N., Smith, M., & Gerrans, P. (2012). Mutual fund selection criteria: Evidence from Malaysia. *Asian Review of Accounting*, 20(2), 140–151. <https://doi.org/10.1108/13217341211242187>
- Khan, M. T. I., Tan, S. H., & Gan, G. G. G. (2019). Advanced Financial Literacy of Malaysian Gen Y Investors and Its Consequences. *Margin*, 13(1), 83–108. <https://doi.org/10.1177/0973801018800085>
- Kimiyagahlan, F., Safari, M., & Mansori, S. (2019). Influential Behavioral Factors on Retirement Planning Behavior: The Case of Malaysia. *Journal of Financial Counseling and Planning*, 30(2), 244–261.
- Kusumawardhini, S. S., Hati, S. R. H., & Daryanti, S. (2016). *Understanding Islamic Brand Purchase Intention: The Effects of Religiosity, Value Consciousness, and Product Involvement*. 158–166. <https://doi.org/10.15405/epsbs.2016.11.02.15>
- Lajuni, N., Wong, W., Ming, P., Yacob, Y., Ting, H., & Jausin, A. (2017). Intention to Use Islamic Banking Products and Its Determinants. *International Journal of Economics and Financial Issues*, 7(1), 329–333.
- Lee, J. M., & Kim, K. T. (2016). The Role of Propensity to Plan on Retirement Savings and Asset Accumulation. *Family and Consumer Sciences Research Journal*, 45(1), 34–48. <https://doi.org/10.1111/fcsr.12179>
- Lee, J. M., Lee, J., & Kim, K. T. (2019). Consumer Financial Well-Being: Knowledge is Not Enough. *Journal of Family and Economic Issues*, 41(2), 218–228. <https://doi.org/10.1007/s10834-019-09649-9>
- Levisauskaite, K. (2010). *Investment Analysis and Portfolio Management*. Kaunas, Lithuania.
- Lynch, J. G. J., Netemeyer, R. G., Spiller, S. A., & Zammit, A. (2010). A Generalizable Scale of Propensity to Plan : The Long and the Short of Planning for Time and for Money. *Journal Of Consumer Research*, 37(June). <https://doi.org/10.1086/649907>
- Malaysian Aviation Commission. (2017). *Aviation Sector Multiplier*. Kuala Lumpur, Malaysia.
- Mansori, S., Sambasivan, M., & Md-Sidin, S. (2015). Acceptance of novel products: The role of religiosity, ethnicity and values. *Marketing Intelligence and Planning*, 33(1), 39–66. <https://doi.org/10.1108/MIP-03-2013-0050>
- Md Nawi, F. A., Wan Daud, W. M. N., Ghazali, P. L., Yazid, A. S., & Shamsuddin, Z. (2018). Islamic Financial Literacy: A Conceptualization and Proposed Measurement. *International Journal of Academic Research in Business and Social Sciences*, 8(12), 629–641. <https://doi.org/10.6007/ijarbs/v8-i12/5061>
- Mohamed, A. A. V. (2017). Choosing the Right Investment Products. *Journal of Wealth Management and Financial Planning*, 4(June), 66–72.
- Mohd Ali, A. N., Ramli, A. L. Y., & Hussain, M. A. (2017). Private Retirement Scheme as a Financial Protection of Old-Age in Malaysia from the Perspective of PRS Providers. *International Journal of Innovation and Business Strategy*, 7(1), 18–25.
- myPF. (2018). Which PRS Funds to Invest in 2018/2019. Retrieved March 10, 2020, from myPF Simplifying Personal Finances website: <https://mypfmy/2018/09/23/best-prs-funds-2018-2019/>
- myPF. (2020). Which PRS Funds to Invest in 2019/2020. Retrieved May 5, 2020, from myPF Simplifying Personal Finances website: <https://mypfmy/2019/10/18/which-prs-funds-to-invest-in-2019-2020/>
- O’Neill, B., Xiao, J. J., & Enslie, K. M. (2016). Propensity to Plan: A Key to Health and Wealth? *Journal of Financial Planning*, 29(3), 42–50.
- Organisation for Economic Co-operation and Development. (2013). *Financial literacy and inclusion: Results of OECD/INFE Survey cross Countries and By Gender*. Paris.
- Organisation for Economic Co-operation and Development. (2016). OECD/INFE International Survey of Adult Financial Literacy Competencies. In *Organisation for Economic Co-operation and Development (OECD)*. Paris.
- Price Waterhouse Coopers. (2009). Shariah-Compliant Funds: A Whole New World of Investment. In *Price Waterhouse Coopers Publications*. Retrieved from <https://www.pwc.com/gx/en/financial-services/islamic-finance-programme/assets/shariah-compliant-funds.pdf>
- Private Pension Administration. (2019). What is PRS? Retrieved November 27, 2019, from Private Pension Administration website: <https://www.ppa.my/prs-and-you/>
- Private Pension Administration. (2020). Fund Performance. Retrieved June 10, 2020, from Private Pension Administration website: <https://www.ppa.my/prs-providers/prs-funds-information/>
- Rabia, S., & Naqvi, A. (2018). Factors Affecting Investment Decision in Banking Sectors of Pakistan : Comparative Study Between Islamic and Conventional Banks. *Research Journal of Finance and Accounting*, 9(3), 33–43.
- Rahman, S. A., Tajudin, A., Fadli, A., & Tajuddin, A. (2018). Determinant Factors of Islamic Financial Literacy In Malaysia. *American Journal of Humanities and Social Sciences Research*, (10), 125–132. Retrieved from www.ajhssr.com
- Rai, K., Dua, S., & Yadav, M. (2019). Association of Financial Attitude, Financial Behaviour and Financial Knowledge Towards Financial Literacy: A Structural Equation Modeling Approach. *FIIB Business Review*, 8(1), 51–60. <https://doi.org/10.1177/2319714519826651>
- Rani, N. S. M. (2015). Consumer Attitudes and Purchase Intentions Toward Islamic Banks: The Influence of Religiosity. *International Journal of Bank Marketing*, 33(2), 1–38. <https://doi.org/http://dx.doi.org/10.1108/IJBM-10-2013-0115>
- Rao, M. (2019, September 19). Investors drawn to local private retirement schemes only because of tax rebates. *The Malaysian Reserve*. Retrieved from <https://themalaysianreserve.com/2019/09/19/investors-drawn-to-local-private-retirement-schemes-only-because-of-tax-rebates/>
- Reilly, F. K., & Brown, K. C. (2012). What is an Investment? In F. K. Reilly & K. C. Brown (Eds.), *Investment Analysis & Portfolio Management* (10th ed.). Ohio, USA: South-Western Cengage Learning.
- Selvanathan, M., Nadarajan, D., Farzana, A., Zamri, M., & Suppramaniam, S. (2018). An Exploratory Study on Customers’ Selection in Choosing Islamic Banking. *International Business Research*, 11(5), 42–49. <https://doi.org/10.5539/ibr.v11n5p42>
- Setiawati, R., Nidar, S. R., Anwar, M., & Masyita, D. (2018). Islamic Financial Literacy : Construct. *Academy of Strategic Management Journal*, 17(4), 1–12.
- Soma, A. M., Primiana, I., Wiryono, S. K., & Febrian, E. (2017). Religiosity and Islamic Banking Product Decision: Survey on Employees of PT Telekomunikasi Indonesia. *Etikonomi*, 16(1), 25–42. <https://doi.org/10.15408/etk.v16i1.4379>
- Tahir, I., & Brimble, M. (2011). Islamic investment behaviour. *International Journal of Islamic and Middle Eastern Finance and Management*, 4(2), 116–130. <https://doi.org/10.1108/17538391111144515>
- The Star. (2019, December 23). Principal sees further growth opportunities in Islamic finance. *The Star*. Retrieved from <https://www.thestar.com.my/business/business-news/2019/12/23/principal-sees-further-growth-opportunities-in-islamic-finance>
- Tuominen, M. C., & Thompson, E. L. (2015). “There Was No Money Left to Save”: Financial Literacy and the Lives of Low-Income People. *Journal of Progressive Human Services*, 26(2), 148–165. <https://doi.org/10.1080/10428232.2015.1018104>
- Worthington, E. L., Wade, N. G., Hight, T. L., Ripley, Jennifer S. McCullough, Michael E. Berry, J. W., Schmitt, M. M., Berry, J. T., & Bursley, Kevin H. O’Connor, L. (2003). The Religious Commitment Inventory--10: Development, refinement, and validation of a brief scale for research and counseling. *Journal of Counseling Psychology*, 50(1), 84–96. <https://doi.org/https://doi.org/10.1037/0022->

0167.50.1.84

- Xiao, J. J., & O'Neill, B. (2018). Propensity to Plan, Financial Capability and Financial Satisfaction. *International Journal of Consumption Studies*, 1–12. <https://doi.org/10.1111/ijcs.12461>
- Yahaya, S., & Ibrahim, H. (2017). Determinants of Awareness to Invest in Shariah-based Private Retirement Scheme (PRS): The Case of Public University Students in Malaysia. In Nadhrah A Kadir, A. R. A. Latiff, A. M. Tayeb, I. N. H. Zainol, M. M. Shaed, L. C. Hong, ... S. R. Rahmat (Eds.), *SOCIAL SCIENCES POSTGRADUATE INTERNATIONAL SEMINAR (SSPIS) 2017* (pp. 639–645). Penang, Malaysia: School of Social Sciences, USM.
- Yahaya, S., Ibrahim, H., Zulkafli, A. H., & Razimi, M. S. A. (2017). Demographics factors and awareness on Shariah-based Private Retirement Scheme among higher learning institution students in Malaysia. *Economics, Management and Sustainability*, 2(2), 86–94. <https://doi.org/10.14254/jems.2017.2-2.9>
- Zabri, S. M., Ahmad, K., & Lian, A. A. L. H. (2016). The awareness of private retirement scheme and the retirement planning practices among private sector employees in Malaysia. *International Journal of Economics and Financial Issues*, 6(6 (Special Issue)), 120–124.
- Zaihan, N., & Noar, M. (2017). The Awareness of Retirement Planning: A Case with International Islamic University Malaysia Employees. *Revelation and Science*, 7(2), 18–23.
- Zainudin, R., Mahdzan, N. S., Che Hashim, R., & Sulaiman, N. A. (2019). Islamic religiosity and Islamic financial asset holdings (IFAH). *Journal of Islamic Accounting and Business Research*, 10(4), 591–606. <https://doi.org/10.1108/JIABR-04-2016-0052>
- Zaman, Z., Mehmood, B., Afab, R., Shahid, M., & Ameen, Y. (2017). Role of Islamic Financial Literacy in the Adoption of Islamic Banking Services: An Empirical Evidence from Lahore, Pakistan. *Journal of Islamic Business and Management (JIBM)*, 7(2), 230–247. <https://doi.org/10.26501/jibm/2017.0702-006>

PERUNTUKAN DANA ZAKAT UNTUK KES-KES DI LUAR JANGKA BERDASARKAN PERSPEKTIF HADITH NABAWI: SATU ANALISIS

Mohd Murshidi Mohd Noor^a, Ahmad Khilmy Abdul Rahim^b & Afnan Faiz Ridzuan Ahmad^c

^{ab}*Pensyarah Kanan, Pusat Pengajian Perniagaan Islam, Universiti Utara Malaysia*

^c*Pusat Pengajian Ilmu Kemanusiaan, Universiti Sains Malaysia*

Abstrak

Dunia kini mengalami penyebaran wabak penyakit pandemik iaitu COVID-19 yang tidak diketahui bila ia akan berakhir. Ia turut memberi kesan kepada ekonomi global dan tempatan. Ramai di kalangan pekerja yang diberhentikan kerana majikan tidak mampu untuk menampung gaji mereka. Justeru, ramai yang menjadi penganggur dalam masa yang singkat. Mereka ini perlu diberi bantuan segera bagi menampung kos kehidupan dalam jangka masa yang wajar. Antara sumber yang dilihat berpotensi memberi sumbangan kepada golongan ini adalah dari dana zakat yang terdapat peruntukan khas untuk kes-kes di luar jangka yang memberi kesan kepada kewangan seseorang. Hal ini berdasarkan kepada hadith Nabawi yang menyebutkan mengenai beberapa golongan yang layak untuk menerima zakat dalam kes-kes tertentu. Objektif kertas kerja ini adalah untuk mendapatkan konsep yang jelas mengenai dana zakat yang diperuntukkan untuk kes-kes di luar jangkaan sebagaimana yang dinyatakan di dalam hadith Nabawi, serta perbincangan hukum di kalangan para fuqaha. Metodologi kajian adalah berdasarkan kepada analisis dokumen yang membicarakan mengenai topik tumpuan. Kesimpulan perbincangan ialah sememangnya terdapat peruntukan khas dari dana zakat untuk kes-kes tertentu yang di luar jangka. Oleh yang demikian, badan yang menguruskan zakat perlu memperuntukkan setiap tahun dana khas ini bagi kes-kes di luar jangkaan yang diambil dari lebih agihan zakat bagi tahun kutipan. Baki tersebut dicadangkan agar tidak dibawa ke tahun agihan seterusnya, tetapi dimasukkan ke dalam akaun khas untuk tujuan simpanan dan pelaburan bagi kes-kes di luar jangkaan.

Katakunci: Hadith Zakat, Lebihan Dana Zakat, Kes Luar Jangkaan

1.0 PENGENALAN

COVID-19 berpunca dari koronavirus yang meletus di negara China, sebelum mula melebarkan sayap kemusnahannya ke seluruh dunia, menjangkiti lebih 1.2 juta umat manusia dan meragut kira-kira 65,000 nyawa. Di seluruh dunia, segala aktiviti terhenti seperti pelancongan dan perniagaan. Akibat wabak tersebut, semuanya tidak bermaya, dan pengangguran berleluasa, harga minyak pula terus merudum (<https://www.astroawani.com/berita-malaysia/covid19-adakah-alam-sedang-bertindak-balas-terhadap-kealpaan-manusia-236990>, diakses pada 22 September 2020). Banyak perniagaan terkesan, terutamanya perniagaan kecil dan sederhana. Rakyat hidup dalam situasi kewangan yang amat mencengkam hingga memaksa mereka meminta bantuan dan sedekah. Ada yang dipaksa untuk keluar dari rumah masing-masing kerana tidak mampu untuk membayar sewa akibat tiada sumber pendapatan. Ada juga yang dipotong gaji dan kehilangan kerja (<https://www.sinarharian.com.my/article/86984/KOLUMNIS/Solusi-bencana-Covid-19>, diakses pada 22 September 2020). Menurut kenyataan Pengarah Eksekutif Persekutuan Majikan Malaysia (MEF), Datuk Shamsuddin Bardan, 100,000 rakyat Malaysia akan kehilangan pekerjaan jika COVID-19 berterusan sehingga penghujung tahun ini (<https://www.utusanborneo.com.my/2020/04/24/covid-19-malaysia-hadapi-bencana-luar-biasa>, diakses pada 22 September 2020). Menerusi situasi kritikal yang berlaku, Islam sentiasa memberikan jalan alternatif kepada mangsa yang terlibat. Sekiranya ditelusuri hadith-hadith mengenai zakat, maka terdapat satu hadith yang menyentuh secara langsung akan situasi yang berlaku ini dengan memberikan jalan keluar bagi mangsa yang terjejas teruk akibat bencana yang menimpa. Hadith tersebut dibahasakan secara mendalam berdasarkan artikel ini.

2.0 FENOMENA COVID-19 DAN KESAN KEPADA PARA PEKERJA

Menurut Pertubuhan Kesihatan Sedunia (WHO), Coronavirus (CoV) adalah sejenis penyakit yang menjangkiti manusia dan termasuk dalam kategori virus Coronaviridae seperti virus SARS (*Severe Acute Respiratory Syndrome*) dan MERS Cov (*Middle Eastern Respiratory Syndrome*). Penghidap virus ini akan mengalami demam dan selesema atau *flu*. Jumlah kes terkini seluruh dunia setakat 18 September 2020 adalah 30,363,118 yang melibatkan 211 buah negara dan jumlah kematian disebabkan virus Covid-19 adalah 950,732. Manakala jumlah kes keseluruhan di Malaysia adalah 10,052 dengan jumlah kematian adalah 128 iaitu 1.27% dan Wilayah Persekutuan Labuan mencatatkan kes terkecil iaitu 23 kes tempatan dan empat kes import (KKM, 2020).

Virus Covid-19 boleh tersebar menerusi tiga cara iaitu menerusi cecair apabila seseorang itu bersin atau batuk tanpa mengikut tatacara yang betul. Cara kedua pula adalah apabila seseorang itu bersentuhan kulit dengan pesakit Covid-19 tanpa sebarang alas. Manakala cara ketiga penularan boleh berlaku kepada seseorang manusia adalah apabila seseorang individu itu menyentuh tempat yang sudah tercemar dengan virus Covid-19 (KKM, 2020)

Bagi memutuskan rantaian penyebaran virus Covid-19, Kerajaan Malaysia di bawah Akta Pencegahan dan Pengawalan Penyakit Berjangkit 1988 dan Akta Polis 1967 telah memperkenalkan Perintah Kawalan Pergerakan (PKP) bermula pada 18 Mac 2020. Semua sektor termasuk ekonomi telah ditutup sepenuhnya dan orang ramai dilarang keluar daripada rumah tanpa sebarang urusan munasabah (Perdana Menteri, 2020). Berikutan itu, 52.6% daripada 163,182 responden yang menyertai kajian khas yang dilakukan oleh Jabatan Perangkaan Malaysia bagi tempoh 23 Mac 2020 hingga 31 Mac 2020 secara atas talian mengatakan Covid-19 sangat memberi kesan kepada impak kewangan sepanjang tempoh PKP. Mereka ini terdiri daripada pelbagai taraf pekerjaan yang berumur 15 tahun dan ke atas kecuali mereka yang berkhidmat sebagai penjawat awam. Penduduk Negeri Sabah menunjukkan angka tertinggi iaitu 66.7% dan diikuti oleh Kelantan iaitu 65.5% yang terkesan akibat pandemik ini. Senarai kesan penularan Covid-19 berdasarkan taraf pekerjaan diterangkan secara terperinci dalam Jadual 1:

Jadual 1: Kesan penularan Covid-19 berdasarkan taraf pekerjaan

<i>Taraf Pekerjaan</i>	<i>Cuti Separuh Gaji</i>	<i>Cuti Tanpa Gaji</i>	<i>Hilang Pekerjaan</i>
<i>Bekerja Sendiri</i>	0.9%	9.2%	46.6%
<i>Majikan</i>	3.8%	14.5%	23.8%
<i>Pekerja Government</i>	0.6%	1.1%	0.4%
<i>Link Companies (GLC)</i>			
<i>Pekerja Swasta</i>	7.0%	13.2%	1.8%
<i>Pekerja Syarikat Multinasional (MNC)</i>	0.9%	2.0%	0.4%

Berdasarkan Jadual 1, 46.6% pekerja yang bekerja sendiri telah kehilangan pekerjaan dan 13.2% pekerja swasta telah diberi cuti tanpa gaji serta 7.0% daripada mereka telah diberikan cuti separuh gaji. Manakala 23.8% majikan telah kehilangan pekerja akibat penularan pandemik ini. Selain itu, 94.8% pekerja yang bekerja sendiri telah mengalami pengurangan pendapatan bulanan. Walau bagaimanapun, 84.1% pekerja yang berkhidmat di GLC tidak terjejas pendapatan bulanan dan mereka menerima gaji seperti biasa. Begitu juga 85.2% pekerja di MNC melaporkan bahawa pendapatan bulanan mereka adalah sama seperti sebelum berlakunya penularan jangkitan wabak Covid-19 (Jabatan Perangkaan Malaysia, 2020).

Menurut Muhyiddin bin Mohd Yassin (2020), sektor ekonomi yang paling terjejas akibat Covid-19 adalah sektor pelancongan dengan anggaran kerugian RM3.37 bilion bermula Januari hingga Februari 2020. Berdasarkan pengumuman yang dibuat oleh Ketua Pegawai Eksekutif AirAsia pada 4 Jun 2020, seramai 111 orang kru kabin, 172 orang juruterbang dan 50 orang jurutera akan diberhentikan kerja (Berita Harian, 2020). Manakala menurut Pengerusi Persatuan Agensi Pelancongan Umrah dan Haji (PAPUH), pengusaha umrah kecil-kecilan dijangka paling terkesan berikutan larangan mengerjakan umrah oleh Kerajaan Arab Saudi susulan penularan jangkitan Covid-19. Anggaran kerugian yang akan ditanggung oleh industri pelancongan negara yang melibatkan ibadat umrah adalah lebih RM100 juta (Berita Harian, 2020).

Sehubungan itu, penangguhan bayaran balik pinjaman atau moratorium yang berkuatkuasa bermula 1 April 2020 telah diperkenalkan bagi mengurangkan beban kewangan pekerja. Berdasarkan data setakat 20 Julai 2020 daripada Bank Negara Malaysia, 93% daripada kesemua peminjam atau lebih 7.7 juta peminjam individu telah mendapat manfaat ini yang bernilai RM38.3 bilion. Manakala 95% daripada keseluruhan peminjam Perindustrian Kecil Sederhana (PKS) iaitu 243,000 peminjam PKS telah mendapat manfaat daripada penangguhan bayaran balik pinjaman dengan nilai RM20.7 bilion (Perdana Menteri, 2020). Berdasarkan kepada fenomena dari kesan COVID-

19 kepada para pekerja seperti yang dinyatakan di atas, maka didapati terdapat sebilangan besar rakyat Malaysia terkesan dengan fenomena tersebut terutamanya mereka yang bekerja sendiri atau mereka yang diberhentikan kerja oleh majikan. Ramai yang diberhentikan kerja oleh para majikan yang tidak mampu membayar gaji para pekerja. Pemberhentian kerja secara tiba-tiba oleh majikan sememangnya memberikan kesan yang besar kepada para pekerja yang terlibat. Bagi mereka yang berniaga untuk sektor-sektor tertentu seperti pelancongan, maka pendapatan mereka terjejas teruk. Walaupun kerajaan menyalurkan banyak bantuan kepada rakyat yang terjejas teruk akibat COVID-19, namun tidak semua bantuan yang diberikan itu dapat menampung keperluan mereka dalam tempoh yang berpatutan. Oleh yang demikian, mereka yang benar-benar terdesak dengan fenomena COVID-19 sehingga jatuh miskin, perlu dan wajar diberikan bantuan zakat sehinggalah dapat memenuhi keperluan hidup mereka dalam tempoh yang wajar, di samping mereka memperoleh bantuan dari sumber-sumber lain.

Sekiranya diperhatikan kepada hadith Nabawi mengenai kes-kes luar jangka sehingga mangsa yang pada asalnya berharta, tiba-tiba jatuh miskin, maka berdasarkan hadith tersebut, mereka yang seperti ini layak memohon dan mendapat bantuan zakat. Oleh yang demikian, hadith seperti ini menjadi satu sandaran yang kuat bagi mewajarkan mereka yang terjejas teruk dengan bencana COVID-19 diberikan bantuan zakat agar keperluan mereka dapat dipenuhi untuk satu tempoh yang wajar, sehinggalah kedudukan kewangan mereka kembali pulih. Bagi merealisasikan maksud hadith ini, maka sewajarnya pihak pengurusan zakat negeri memperuntukan satu tabung khas untuk tujuan tersebut yang diambil daripada dana lebihan zakat. Hal ini kerana jika diambil dari dana sedia ada, maka ianya disalurkan kepada asnaf untuk kes-kes biasa yang tidak melibatkan kes-kes di luar jangka. Bagi kes-kes kecemasan, maka ianya memerlukan satu tabung khas untuk tujuan tersebut kerana tempohnya yang tidak pasti untuk digunakan dana sedemikian. Hadith tersebut dan huraianya oleh para ulama, dibincangkan dalam bahagian berikutnya.

3.0 HADITH ZAKAT TENTANG KES DI LUAR JANGKAAN

Hadith tentang zakat yang menceritakan mengenai kes di luar jangka adalah seperti berikut:

وَعَنْ قَيْصَةَ بْنِ مُحَمَّدٍ الْهَلَالِيِّ - رَضِيَ اللَّهُ عَنْهُ - قَالَ: قَالَ رَسُولُ اللَّهِ - صَلَّى اللَّهُ عَلَيْهِ وَسَلَّمَ: «إِنَّ الْمَسْأَلَةَ لَا تَحِلُّ إِلَّا لِأَحَدٍ ثَلَاثَةً: رَجُلٌ تَحْمَلُ حَمَالَةً، فَحَلَّتْ لَهُ الْمَسْأَلَةُ حَتَّى يُصِيبَهَا، ثُمَّ يُمْسِكَ، وَرَجُلٌ أَصَابَتْهُ جَائِحَةٌ، إِجْتَا حَتَّ مَالَهُ، فَحَلَّتْ لَهُ الْمَسْأَلَةُ حَتَّى يُصِيبَ قَوْمًا مِنْ عَيْشٍ، وَرَجُلٌ أَصَابَتْهُ فَاقَةٌ حَتَّى يَقُومَ ثَلَاثَةً مِنْ ذَوِي الْحِجَى مِنْ قَوْمِهِ: لَقَدْ أَصَابَتْ فُلَانًا فَاقَةٌ؛ فَحَلَّتْ لَهُ الْمَسْأَلَةُ حَتَّى يُصِيبَ قَوْمًا مِنْ عَيْشٍ، فَمَا سِوَاهُنَّ مِنَ الْمَسْأَلَةِ يَا قَيْصَةُ سَحَتْ يَأْكُلُهَا [صَاحِبُهَا] سَحْتًا

Maksudnya: Dan diriwayatkan daripada Qabisah bin Mukhariq al-Hilali R.A. ia berkata: telah bersabda Rasulullah S.A.W.: Sesungguhnya meminta-minta sedekah itu tiada melainkan bagi seorang daripada tiga: Seseorang lelaki yang menanggung sesuatu tanggungan seperti hutang atau diyat atau seumpamanya, maka halal baginya minta sedekah hingga ia memperolehinya, kemudian dia harus menahan diri. Kemudian orang yang kena bencana hingga habis seluruh hartanya, maka halal baginya meminta-minta sehingga ia mendapatkan kehidupan yang tetap; Dan orang yang ditimpa kemalangan sehingga orang yang berakal daripada kaumnya berkata: Sungguh si fulan telah ditimpa kemalangan hidup, maka halal baginya meminta-minta sehingga mendapat sandaran hidup yang tetap. Adapun selain daripada itu hai Qabisah, adalah haram, dan orang yang makan harta itu bererti makan yang haram.

a) Takhrij Hadith

1. *al-Kitab al-Musannaf Fi al-Ahadith Wa al-'Athar*, nombor hadith 10685.
2. *Musnad al-Imam Ahmad Bin Hanbal*, nombor hadith 20601.
3. *Musnad al-Darimi al-Ma'ruf Bi Sunan al-Darimi*, nombor hadith 1720.
4. *al-Musnad al-Sahih al-Mukhtasar Bi Naql al-'Adl Ila Rasulillah Sallahu 'Alayh Wa Sallam*, nombor hadith 109 – (1044).

5. *Sunan Abi Dawud*, nombor hadith 1640.
6. *al-Sunan al-Kubra*, nombor hadith 2371.
7. *Sahih Ibn Khuzaymah*, nombor hadith 2359.
8. *al-Ihsan Fi Taqrib Sahih Ibn Hibban*, nombor hadith 3291.
9. *al-Mu'jam al-Kabir*, nombor hadith 947.
10. *al-Sunan al-Kubra*, nombor hadith 13194.

b) Sanad Periwatan Dan Status Hadith

Dalam salah satu sanad hadith yang terdapat di dalam karya al-Mu'jam al-Saghir Li al-Tabrani, al-Tabrani (1985) mengatakan bahawa perawi yang meriwayatkan hadith ini datangnya daripada Abu Hammam daripada 'Ubaydillah bin al-Hasan al-'Anbari al-Qadi. Salih bin Muqatil berseorangan meriwayatkan hadith ini daripada bapanya. Al-Ishbili (1999) mengatakan bahawa al-Bukhari tidak meriwayatkan hadith ini, demikian juga periwatan yang berkaitan dengan sahabat yang bernama Qabisah, tidak terdapat di dalam Sahih al-Bukhari. Menurut Abu al-Qasim al-Harabi al-Hurfi (2007), al-Baghawi (1983) dan al-Tibrizi (1985), hadith ini berstatus sahih yang diriwayatkan oleh Muslim daripada Yahya bin Yahya al-Naysaburi dan daripada Abu Raja' Qutaybah bin Sa'id al-Baghilani. Kesemua jalur ini sampai kepada Abu Isma'il Hammad bin Zayd bin Dirham al-Basari daripada Harun bin Riyab. Oleh yang demikian, dapat disimpulkan bahawa hadith ini berstatus sahih.

c) Ulasan Hadith

Berdasarkan hadith, Nabi S.A.W. menyebutkan tiga golongan yang layak menerima zakat. Golongan yang pertama ialah golongan yang berhutang untuk tujuan mendamaikan pihak yang bergaduh di kalangan umat Islam. Kedua golongan yang ditimpa bencana lalu memusnahkan hartanya dan ketiga golongan yang kehilangan harta disebabkan sesuatu perkara yang hanya diketahui oleh orang yang mengetahui keadaan kewangannya. Penulis menerusi artikel ini hanya akan mengulas untuk golongan kedua dan ketiga sahaja kerana bersesuaian dengan topik perbincangan artikel iaitu dana zakat untuk kes-kes luar jangka bersempena wabak pandemik COVID-19. Persamaan kedua-dua golongan ini ialah mereka pada asalnya berharta, tiba-tiba berlaku sesuatu yang di luar jangkaan yang menyebabkan harta mereka tiada dan jatuh miskin.

Al-Baghawi (1983) mengatakan bahawa dua orang lelaki yang terkena bencana seperti yang disebutkan dalam hadith, sebelum terkena bencana itu, mereka dikenali di kalangan orang ramai sebagai golongan yang berharta. Oleh yang demikian, boleh dikatakan bahawa pada asalnya mereka tidak tergolong dalam kalangan asnaf yang layak menerima bantuan zakat. Setelah mereka ditimpa bencana sehingga jatuh miskin, maka mereka layak untuk menerima bantuan zakat kerana mereka menjadi golongan yang memerlukan bantuan orang ramai (Ibn al-Athir, 2005). Bencana yang menimpa itu sehingga menyebabkan kesemua harta atau sebahagian harta musnah seperti terkena banjir, terbakar dan selainnya (Abu al-Ma'ali, 2004). Walaupun ulasan para ulama terdahulu tidak memberikan contoh penyakit pandemik sebagai bencana, namun bencana COVID-19 yang berlaku kini adalah serupa dengan bencana alam yang dihadapi oleh seseorang kerana mengakibatkan kehilangan harta secara tiba-tiba.

Al-Khattabi (1932) mengatakan bahawa kefakiran berdasarkan hadith terbahagi kepada dua iaitu kefakiran zahir dan kefakiran batin. Kefakiran zahir iaitu seseorang yang ditimpa bencana terhadap hartanya yang tampak zahir, lalu dengan bencana itu menyukarkan hidupnya atau sehingga tiada harta yang tinggal bagi menampung keperluan hidupnya (al-San'ani, t.t.). Bencana pada harta yang tampak zahir adalah berdasarkan kepada 'uruf semasa seperti kejadian banjir yang menenggelamkan harta benda, kebakaran yang memusnahkan harta, cuaca sejuk yang memusnahkan tanaman dan buah-buahan, dan seumpamanya (al-Khattabi, 1932). Misalnya seseorang yang memiliki kebun, apabila tertimpa bencana, tiada suatu pun yang tinggal dari hasil kebun itu untuk keperluan dirinya dan tanggungannya (al-Rajhi, 2018). Sehubungan dengan itu, bencana COVID-19 berdasarkan kepada 'uruf semasa boleh dikatakan menyerupai bencana alam kerana memberi kesan kepada harta benda seseorang. Namun begitu, terdapat sedikit perbezaan antara bencana alam dengan bencana COVID-19 dari sudut kejelasan ianya berlaku. Kesemua bencana alam tampak jelas berlaku kepada mangsa. Manakala COVID-19 tidak sejelas bencana alam yang berlaku ke atas mangsa. Walau bagaimana pun, apabila berlaku bencana kepada seseorang lalu memusnahkan hartanya dan ia menjadi fakir, maka halal baginya untuk memohon dan memperoleh bantuan zakat serta wajib ke atas orang ramai memberikan bantuan kepadanya kerana ia berhak mendapat bantuan (al-Khattabi, 1932).

Kefakiran batin pula ialah bencana yang tertimpa ke atas seseorang yang tidak tampak kesannya di sisi pandangan khalayak ramai. Gambarannya ialah seseorang yang memiliki harta, tiba-tiba hartanya musnah dengan sebab-sebab

tertentu seperti dirompak, dikhianati dan seumpamanya. Apabila berlaku demikian maka terdapat unsur keraguan akan kefakirannya kerana kesan fakir itu tidak tampak jelas pada mangsa (al-Khattabi, 1932). Berkaitan dengan kefakiran batin ini, penulis berpandangan bahawa COVID-19 adalah sejenis bencana yang membawa kepada kefakiran batin kerana bencana yang berlaku itu tidak memberikan kesan yang jelas kepada harta seseorang, melainkan keadaan harta mangsa yang terlibat diselidiki dan dilaporkan kepada pihak berwajib. Mahmud al-Subki (1353H) mengatakan bahawa orang ditimpa kefakiran batin sebelum ini ia masyhur di kalangan komunitinya sebagai seorang yang berharta, tetapi tiba-tiba menjadi fakir yang disaksikan oleh tiga orang berakal di kalangan komunitinya. Orang yang seperti ini berhak mendapat bantuan zakat. Dalam kes COVID-19, mangsa kebiasaannya di kalangan individu yang bekerja sendiri, atau bekerja dengan majikan, lalu diberhentikan kerja serta merta. Golongan ini yang ingin memohon zakat kecemasan, perlu menghubungi pihak berwajib bagi proses pengecaman dan bantuan. Oleh yang demikian, mangsa kefakiran batin tidak diberikan bantuan zakat dengan begitu sahaja, melainkan diminta bukti menerusi pengesahan orang yang mengetahui akan hal keadaan kewangannya, atau dengan cara lain yang membuktikan kedudukan kewangan mangsa. Apabila jelas kedudukan kewangannya, maka barulah bantuan zakat diberikan. Berdasarkan hadith, bagi mengesahkan keadaan kewangan mangsa, maka perlu perakuan daripada tiga orang berakal daripada komunitinya sendiri yang menyatakan bahawa si fulan telah jatuh fakir. Tiga orang yang disebutkan dalam hadith bukanlah dalam kategori saksi (al-Khattabi, 1932) kerana dalam permasalahannya saksi, yang diperlukan hanya dua orang sahaja. Perkara yang dipentingkan dalam permasalahan ini ialah berita tentang keadaan mangsa adalah masyhur di kalangan komunitinya sendiri. Sekurang-kurangnya tiga orang mengesahkan keadaan kewangan mangsa kerana tiga orang adalah bilangan minima untuk sampai ke tahap masyhur (al-Qadi 'Iyad, 1998). Sekiranya sekumpulan orang di kalangan komunitinya, jirannya, kaum kerabatnya (al-Muzhiri, 2012) atau orang yang ada kemahiran mengenai penilaian terhadap kewangan seseorang mengatakan bahawa orang yang ditimpa bencana itu bercakap benar, maka ia layak menerima bantuan zakat (al-Khattabi, 1932). Namun menurut al-Sindi (2010), perkara yang dimaksudkan oleh hadith ialah fakta yang benar daripada mangsa, bukannya berdasarkan agakan dan khayalan. Apabila keadaan kewangan mangsa dapat disahkan dengan apa cara sekalipun misalnya pada zaman kini mangsa perlu mengisi borang untuk diajukan kepada pihak berwajib, maka hal ini juga adalah dibenarkan walaupun tanpa saksi. Sekiranya ada saksi, maka hal tersebut dapat menguatkan lagi permohonan mangsa.

Menurut al-Baydawi (2012), tiada sesiapa pun memberikan pandangan bahawa bagi mensabitkan kefakiran seseorang, dimestikan mendapat penyaksian daripada tiga orang saksi. Bilangan itu disebutkan dalam hadith adalah sebagai satu galakan dan sikap berhati-hati, bagi mengelak mangsa daripada ditohmah oleh orang ramai, sebaliknya mendorong mereka untuk membantu mangsa. Hal ini kerana tidak halal seseorang itu memohon zakat melainkan ia dalam kategori fakir, miskin, atau selain kedua-dua golongan ini di kalangan asnaf zakat (al-Muzhiri, 2012). Al-Nawawi (2004) mengatakan bahawa jumhur ulama menjelaskan dua orang yang adil pun boleh diterima pengakuan mereka bagi kes seperti ini. Penyaksian sekurang-kurangnya dua orang saksi adalah bagi mangsa yang memang diketahui memiliki harta. Sekiranya mangsa tidak diketahui hartanya, maka pengakuannya sebagai fakir (tidak memiliki harta) boleh diterima (al-Saharanfuri, 2006) kerana berdasarkan kepada hukum asal iaitu manusia pada asalnya tidak memiliki harta (Mahmud al-Subki, 1353H). Bantuan zakat yang diperoleh adalah dalam kategori fakir dan miskin, bukannya dalam kategori *al-gharimin* (al-Ramli, 2016).

Berdasarkan kepada keterangan di atas maka disyaratkan orang yang jatuh miskin untuk kefakiran jenis batin, mestilah keadaan kewangannya dapat disahkan benar, dan amat digalakkan orang-orang di sekelilingnya mengesahkan keadaan kewangan mangsa. Dakwaan mulut sahaja daripada mangsa tanpa bukti adalah tidak diterima. Tindakan mengisi borang bagi permohonan bantuan zakat kecemasan adalah salah satu perbuatan untuk mengesahkan kedudukan kewangannya. Sebahagian ulama al-Shafi'iyah mensyaratkan tiga orang berdasarkan zahir hadith, sedangkan jumhur ulama menyatakan memadai dengan dua orang yang dikiaskan dengan segala hukum penyaksian. Namun, disunatkan juga untuk mengambil tiga orang (al-Maghribi, 2003). Walau bagaimanapun, penulis cenderung kepada pandangan yang dikemukakan oleh al-Sindi (2010) yang menyatakan bahawa perkara yang dikehendaki oleh hadith adalah pengesahan kedudukan kewangan mangsa dengan apa cara sekalipun walau bukan dengan saksi. Kefakiran jenis zahir pula tidak disyaratkan sedemikian kerana telah masyhur dan maklum di kalangan orang ramai akan keadaan mangsa (al-Qadi 'Iyad, 1998).

Bantuan zakat yang diberikan kepada kedua-dua mangsa sehinggalah mereka dapat memenuhi atau menampung keperluan hidup (al-Baghawi, 1983) diri sendiri dan orang yang di bawah tanggungannya (Ibn al-Athir, 2005). Apabila mereka memperoleh bantuan zakat yang dapat menampung keperluan hidup, setelah itu mereka tidak berhak lagi untuk memohon bantuan zakat. Keperluan yang dimaksudkan di sini ialah keperluan yang mendesak ('Abd al-Ghani, 2009) seumpama makanan asasi dan pakaian (al-Muzhiri, 2012) yang dikenali sebagai keperluan *daruri* (al-Sindi, 2010). Bantuan yang diberikan itu boleh dalam pelbagai bentuk walaupun selain kewangan (Ibn al-Athir, 2005), asalkan keperluan hidup mangsa dan orang yang berada di bawah tanggungannya dapat dipenuhi.

Terdapat satu hadith yang menjelaskan keperluan seseorang itu terpenuhi adalah dengan ia merasai kenyang untuk sehari semalam. Hadith tersebut ialah:

قِيلَ: يَا رَسُولَ اللَّهِ، وَمَا الْعَنَاءُ الَّذِي لَا يَنْبَغِي مَعَهُ الْمَسْأَلَةُ قَالَ: «أَنْ يَكُونَ لَهُ شِبَعُ يَوْمٍ
وَلَيْلَةٍ أَوْ لَيْلَةٍ وَيَوْمٍ»

Maksudnya: *Rasulullah ditanya: Wahai Rasulullah! Apakah yang dikatakan seseorang itu telah cukup keperluannya sehingga ia tidak sepatutnya lagi untuk memohon zakat? Baginda bersabda: "Sesuatu yang dapat memberikan ia kenyang untuk sehari semalam".* (Sahih Ibn Khuzaymah, nombor hadith 2391).

Makna daripada hadith ialah mengenai konsep *kifayah* (kecukupan) dalam memenuhi keperluan seseorang. Keperluan seseorang pula adalah berbeza-beza antara satu sama lain (Ibn al-Athir, 2005). Apatah lagi keperluan umat manusia pada zaman kini yang begitu kompleks. Dasar *hadd al-kifayah* yang perlu diguna pakai dalam pemberian bantuan kepada yang memerlukan adalah berdasarkan kepada status ekonomi sebuah kehidupan. *Hadd al-kifayah* setiap kawasan adalah berbeza bergantung kepada keperluan harian di mana keperluan di Bandar tentulah lebih tinggi berbanding dengan luar bandar (Muhammad Syarif Omer dan Mohd Sadad Mahmud, 2019).

Ibn al-Athir (2005) juga menyebutkan tafsiran kefakiran yang dimaksudkan oleh hadith termasuklah pekerjaan semasa mangsa yang tidak dapat memenuhi keperluan diri dan orang yang di bawah tanggungannya. Dengan arti kata lain, katakan seseorang itu boleh mendapatkan pekerjaan dalam masa terdekat setelah diberhentikan kerja oleh majikan dalam tempoh bencana COVID-19 atau mendapatkan pekerjaan yang sesuai dengannya jika ia bekerja sendiri, tetapi pekerjaan yang diperoleh masih tidak dapat menampung keperluan diri dan orang yang di bawah tanggungannya, maka orang yang seperti ini layak diberikan bantuan zakat sehinggalah ia mampu berdiri sendiri untuk menyara hidup. Ibn al-Athir (2005) turut memberikan pandangan bahawa sekiranya mangsa telah mendapat pekerjaan yang bersesuaian dengannya dan dapat menampung keperluan hidupnya dan orang yang di bawah tanggungannya, maka ia tidak boleh lagi diberikan bantuan zakat setelah itu. Al-'Ayni (2008) menjelaskan bahawa *istifadah* hukum daripada hadith ialah seseorang fakir yang walaupun dalam keadaan sihat dan mampu bekerja, halal baginya mendapatkan bantuan zakat kerana tidak disyaratkan ia mesti seseorang yang tidak mampu mendapatkan pekerjaan disebabkan penyakit yang tidak diharapkan sembuh dan sebagainya. Bantuan yang diberikan hanyalah untuk memenuhi keperluannya, bukannya untuk memperbanyakkan hartanya. Sekiranya seseorang itu memohon bantuan zakat dengan tujuan untuk memperbanyakkan harta, maka hukumnya adalah haram (al-'Ayni, 2008). Jelas di sini bahawa, mangsa yang kehilangan harta kesan dari bencana COVID-19 adalah layak untuk memohon bantuan zakat walaupun mereka di kalangan yang mampu mencari pekerjaan. Bantuan yang diberikan adalah untuk sementara waktu sahaja, sehinggalah kedudukan kewangan mereka kembali pulih. Dalam tempoh COVID-19, mendapatkan pekerjaan yang sesuai dalam masa yang singkat untuk individu-individu tertentu adalah menjadi satu kemustahilan bagi mereka. Justeru, selagi mana mereka belum mendapatkan pekerjaan yang sesuai, maka layak bagi mereka untuk mendapatkan bantuan zakat. Sekiranya mereka sudah memperolehi pekerjaan yang sesuai untuk menampung keperluan hidupnya dan orang yang di bawah tanggungannya, maka barulah haram ia mendapat bantuan zakat.

4.0 ANALISIS HADITH

Dalam bahagian ini, penulis akan membicarakan mengenai penghuraian yang lebih menjurus ke arah permasalahan semasa yang berkaitan dengan perbincangan hadith tentang mangsa yang terlibat dengan bencana harta yang dibantu menerusi dana zakat.

a) Adakah COVID-19 Satu Bencana?

Di dalam hadith, disebutkan mengenai bencana sama ada zahir mahupun batin yang tertimpa mangsa, sehingga menyebabkan kewangan mangsa terjejas. Adakah COVID-19 sesuai dikatakan sebagai bencana seperti yang dinyatakan oleh hadith? Menurut Kamus Dewan, bencana bermaksud sesuatu malapetaka atau kemalangan yang menimpa atau kesusahan yang disebabkan oleh sesuatu (<https://prpm.dbp.gov.my/Cari1?keyword=bencana&d=176312&#LIHATSINI>, diakses pada 23 September 2020). Menurut sumber daripada Wikipedia, COVID-19 merupakan bencana besar kerana boleh membawa kepada kematian. Sehingga 5 April 2020, hampir 64,734 kematian telah dikaitkan

dengan COVID-19 (https://ms.wikipedia.org/wiki/Pandemik_COVID-19#Epidemiologi, diakses pada 22 September 2020). Oleh yang demikian, boleh dikatakan bahawa COVID-19 merupakan satu bencana yang tidak kurang hebatnya dengan bencana alam yang dihadapi oleh manusia sehingga harta benda terjejas. Malapetaka yang menimpa umat manusia pada ketika ini memberi kesan dari sudut ekonomi dan pendapatan isi rumah. Terdapat beberapa individu yang jatuh miskin dengan serta merta disebabkan kehilangan punca pendapatan menerusi bencana COVID-19.

Berdasarkan kepada huraian hadith, jelas bahawa mereka yang terkena bencana lalu memberikan kesan kepada harta sehingga jatuh miskin, layak menerima bantuan zakat. Menerusi perbincangan ulama terdahulu, mereka tidak menyentuh secara langsung bencana yang berbentuk virus pandemik. Namun begitu, definisi yang diberikan oleh mereka amat jelas iaitu bencana yang tertimpa seseorang yang berharta menyebabkan ia jatuh miskin serta merta, maka ia layak untuk menerima bantuan zakat. Oleh yang demikian, wabak pandemik COVID-19 merupakan bencana besar yang semua orang maklum kesannya kepada kesihatan dan ekonomi sesebuah Negara, maka wajar untuk dikategorikan wabak tersebut sebagai bencana yang memberi kesan kepada harta seseorang.

b) Fakir dan Miskin Dalam Situasi Bencana

Berdasarkan hadith, mangsa yang terlibat adalah dikira sebagai fakir miskin yang pada asalnya mempunyai harta yang mencukupi untuk keperluan harian. Adakah mangsa COVID-19 kini, boleh dikategorikan sebagai fakir miskin, sebagaimana yang dimaksudkan oleh hadith? Dalam situasi bencana COVID-19, seseorang yang pada asalnya berharta, namun dengan serta merta jatuh miskin, kesan daripada penularan virus di kalangan penduduk dunia. Berdasarkan fakta yang dinyatakan oleh Jabatan Perangkaan Malaysia, 46.6% pekerja yang bekerja sendiri telah kehilangan pekerjaan dan 13.2% pekerja swasta telah diberikurcuti tanpa gaji serta 7.0% daripada mereka telah diberikan cuti separuh gaji. Manakala 23.8% majikan telah kehilangan pekerja akibat penularan pandemik ini (Jabatan Perangkaan Malaysia, 2020). Oleh yang demikian, mangsa yang terlibat dengan fenomena COVID-19 perlu dikategorikan dalam golongan khas kerana sebelum ini mereka tidak pernah menerima sebarang bantuan dan pada mana-mana institusi disebabkan mereka berharta. Bencana COVID-19 yang melanda dunia telah mengubah hidup mereka daripada orang berharta menjadi orang yang tidak berharta. Walaupun mereka digolongkan dalam kategori khas, namun mereka tetap di bawah asnaf fakir miskin sebagaimana yang disebutkan di dalam al-Quran.

c) Had Kifayah Untuk Situasi Bencana

Di dalam hadith, disebutkan mengenai golongan yang terjejas teruk disebabkan bencana yang menimpanya lalu jatuh miskin. Mereka yang dikatakan miskin itu disebabkan pendapatan semasanya telah jatuh di bawah dari paras *had kifayah*. Sehubungan dengan itu, sekiranya ia mengalami bencana, tetapi hartanya masih melepasi paras *had kifayah*, maka ia masih lagi tidak dikira sebagai miskin. Justeru, *had kifayah* adalah sangat penting bagi menentukan seseorang itu telah jatuh miskin atau tidak dalam situasi bencana yang menimpa. *Had kifayah* dalam situasi bencana COVID-19 adalah sama sahaja dengan *had kifayah* yang telah sedia ada mengenainya. Hal ini kerana *had kifayah* ditentukan oleh institusi zakat bagi sesebuah negeri. Jabatan Wakaf, Haji dan Zakat (JAWHAR, 2007) telah menggariskan beberapa komponen utama dalam menentukan keperluan *had kifayah* seperti tempat tinggal, pakaian, makanan, kesihatan, pendidikan dan pengangkutan berdasarkan *maqasid al-shari'ah*. Oleh yang demikian, mereka yang terjejas teruk dengan bencana COVID-19 sehingga pendapatan mereka menjunam di bawah paras *had kifayah*, selayaknya mereka memperoleh bantuan dari dana zakat. Mereka perlu dibantu sehinggalah beberapa keperluan asas dapat dipenuhi seperti makan minum, pakaian, pendidikan, kesihatan dan sebagainya.

d) Dana Lebihan Zakat Untuk Kes-Kes Luar Jangka

Dalam proses agihan zakat, terdapat kategori asnaf yang mempunyai bilangan kecil yang sekiranya diagihkan, tidaklah mencapai jumlah kutipan untuk tahun tersebut. Apabila terjadi demikian, maka terdapat kategori asnaf yang jumlah agihannya adalah sedikit berbanding kutipan. Justeru, terdapat lebihan dana bagi kategori asnaf tersebut yang tidak dapat diagihkan sepenuhnya pada tahun semasa.

Al-Nawawi (t.t.) menyebut, kalau kelapan-lapan asnaf ada, setiap dari asnaf itu dapat 1/8. Tetapi kalau yang ada lima asnaf sahaja zakat itu akan dibahagikan lima sahaja dan setiap asnaf mendapat satu bahagian. Dalam mazhab Maliki dan Hanafi, zakat tidak wajib diagihkan kepada kesemua asnaf yang ada, tetapi cukup kepada mana-mana asnaf sahaja (Mahmood Zuhdi, 2003). Dalam melakukan pengagihan kepada kelapan-lapan asnaf yang ada itu tidaklah perlu mereka semua diberi kadar yang sama. Sebaliknya pemberian harus berdasarkan bilangan penerimaan dalam satu-satu asnaf itu dan keperluan sebenar mereka. Harus dikeluarkan zakat hanya kepada sesetengah golongan atau asnaf sahaja, sesuai dengan kepentingan pada waktu itu. Begitu juga tidak perlu diberikan kadar yang sama kepada setiap orang dalam satu golongan. Bagaimanapun, perbezaan berkenaan haruslah didasarkan kepada pertimbangan yang adil (al-Qaradawi, 1973). Sekiranya pandangan ini diambil kira, sudah tentulah terdapat lebihan dana yang tidak teragih. Lebihan dana itu seeloknya disimpan atau dilaburkan untuk kepentingan asnaf pada kes-kes kecemasan.

Sehubungan dengan itu, penulis mencadangkan agar sebahagian dana itu atau kesemuanya disimpan atau dilaburkan

bagi tujuan kes-kes kecemasan. Lagi pun, pelaburan dana zakat telah pun dibincangkan oleh pihak berautoriti iaitu JAKIM menerusi Mesyuarat Lembaga Fatwa Negeri Sarawak Kali Ke 21 pada 25 September 2012 yang mengharuskan pelaburan harta zakat mengikut syarat-syarat yang ditetapkan (<http://e-smaf.islam.gov.my/e-smaf/index.php/main/mainv1/fatwa/pr/15946>, diakses pada 22 September 2020). Biasanya dana lebihan ini akan disalurkan kepada kategori asnaf yang sangat memerlukan iaitu fakir dan miskin. Sebagaimana yang disebutkan dalam hadith, mangsa yang terlibat termasuk dalam kategori asnaf fakir miskin buat sementara waktu, kerana mereka pada asalnya memiliki harta seperti orang lain sebelum ditimpa bencana.

5.0 TINDAKAN SEMASA OLEH INSTITUSI ZAKAT

Sekiranya ditelusuri kepada tindakan oleh institusi-institusi zakat negeri, maka telah ada peruntukan oleh mereka terhadap asnaf-asnaf di luar jangka ini. Majlis Agama Islam Wilayah Persekutuan telah melancarkan Bantuan Khas COVID-19 bagi membantu meringankan beban orang awam susulan Perintah Kawalan Pergerakan (PKP) akibat penularan wabak COVID-19. Bantuan diberikan kepada penjaja/peniaga kecil, pekerja dan individu yang terjejas sumber pendapatan agar dapat meneruskan kelangsungan hidup dalam tempoh ini. Golongan yang dibantu untuk Bantuan Khas ini ialah golongan pendapatan pertengahan yang terjejas dengan Perintah Kawalan Pergerakan wabak COVID-19 dan golongan penjaja/peniaga kecil dan pekerja B40 agar mereka dapat meneruskan kehidupan dengan lebih baik, di samping tidak menerima Bantuan Kewangan Bulanan MAIWP. Skim sedia ada yang digunakan untuk kes-kes seperti ini ialah Skim Bantuan Kecemasan. Jumlah bantuan yang diberikan adalah tertakluk kepada keperluan dengan jumlah isi rumah diambil kira. Kriteria untuk mewajarkan mereka mendapat bantuan bagi skim ini ialah mereka menetap di Wilayah Persekutuan dan terputus perbelanjaan kerana tidak ada sumber pendapatan akibat PKP. Dana yang diambil bagi memenuhi skim ini ialah daripada sumber zakat yang diperuntukkan sebanyak RM3 juta di bawah skim Bantuan Zakat Kecemasan COVID-19 (<https://www.maiwp.gov.my/i/index.php/en/maklumat-bantuan-kecemasan-musaadah-covid19-maiwp>, diakses pada 22 September 2020). Berdasarkan kepada tindakan yang dilakukan oleh MAIWP ini maka jelaslah bahawa tindakan tersebut menepati maksud hadith yang memperuntukkan dana bagi mereka yang terjejas sumber pendapatan akibat bencana yang menimpa.

Lembaga Zakat Selangor (LZS) turut menyalurkan bantuan zakat kepada 29,000 orang penerima Bantuan Khas COVID-19. Pembayaran ini melibatkan penyaluran agihan zakat sebanyak RM14.0 juta dan dimanfaatkan oleh 29,000 penerima layak. Seramai 9,000 penerima adalah dalam kalangan asnaf fakir, miskin dan muafak yang menerima bantuan khas sebanyak RM500 per keluarga dengan jumlah keseluruhan agihan zakat sebanyak RM4.5 juta. Sebanyak 20,000 penerima lagi dalam kalangan B40 khususnya golongan penjaja/peniaga kecil dan keluarga B40 yang terjejas sumber pendapatan, turut menerima bantuan maksimum sehingga RM500. Ia melibatkan jumlah agihan zakat sebanyak RM9.5 juta menggunakan peruntukan asnaf *fi sabilillah* (<https://www.zakat.selangor.com.my/terkini/29000-penerima-bantuan-khas-covid-19-lzs-terima-manfaat-agihan-zakat/>, diakses pada 22 September 2020). Berdasarkan kepada laporan yang diberikan ini bermakna terdapat peruntukan khas untuk mangsa yang terjejas sumber pendapatan khususnya di kalangan penjaja/peniaga kecil dan keluarga dalam kategori B40. Jumlah zakat yang diperuntukkan adalah sebanyak RM9.5 juta bagi 20,000 orang penerima yang diambil dari peruntukan asnaf *fi sabilillah*. Peruntukan ini diambil kemungkinan terdapat lebihan dana bagi bahagian ini yang masih belum teragih. Lebihan dana tersebut disalurkan kepada para penerima untuk kes-kes kecemasan.

Zakat Pulau Pinang melancarkan Pakej Bantuan Khas Ekoran Penularan Covid-19 untuk fasa kedua bagi para pemandu teksi, pemandu khidmat dan pekerja gaji harian yang memperoleh pendapatan yang tidak seberapa. Hal ini kerana mereka sangat terkesan dan bakal kehilangan punca pendapatan memandangkan itu lah punca utama sumber pendapatan keluarga. Bantuan zakat yang diberikan bertujuan meringankan beban golongan asnaf fakir dan miskin yang berdepan masalah kehilangan punca pendapatan keluarga, seterusnya diharap mampu memberikan sinar kegembiraan di sebalik kebimbangan berkenaan penularan wabak Covid-19 dan kesempitan wang. Pakej Bantuan Khas ini menyasarkan kumpulan asnaf berikut iaitu pemandu teksi sepenuh masa, pemandu khidmat e-hailing sepenuh masa, dan pekerja gaji harian sepenuh masa (<https://www.zakatpenang.com/zpp/index.php/agihan/pakej-bantuan-khas-zakat-covid-19-fasa-2>, diakses pada 22 September 2020). Berdasarkan bantuan yang diberikan ini, bermakna terdapat dana khas yang diperuntukkan oleh Zakat Pulau Pinang untuk para asnaf segera dalam bencana COVID-19. Dana-dana yang diberikan itu adalah bertepatan dengan maksud hadith yang membenarkan para asnaf segera, memohon bantuan zakat.

6.0 CADANGAN

Berdasarkan kepada perbincangan di atas, maka penulis mencadangkan dua perkara berikut iaitu: Sekiranya pendapatan mangsa yang terjejas teruk akibat fenomena COVID-19 di bawah had *kifayah* yang telah ditetapkan oleh institusi zakat negeri terutamanya mereka yang bekerja sendiri atau diberhentikan kerja oleh majikan,

maka sewajarnya mereka diberi bantuan zakat, sementara perniagaan yang dijalankan oleh mereka pulih seperti sedia kala, atau mendapat pekerjaan yang bersesuaian, seterusnya pendapatan mereka kembali mencapai had *kifayah* yang telah ditetapkan oleh institusi zakat negeri.

Pengurusan zakat negeri perlu memikirkan dana khas untuk kes-kes yang di luar jangka ini dengan memberikan tumpuan terhadap dana lebihan pada setiap tahun. Dana lebihan itu perlu dimasukkan ke dalam akaun khas yang tidak dibawa ke tahun berikutnya, agar dana tersebut dapat ditingkatkan menerusi aktiviti pelaburan dan sebagainya. Manfaat tabung ini adalah semata-mata untuk asnaf fakir miskin bagi kes-kes di luar jangka.

7.0

KESIMPULAN

Berdasarkan perbincangan di atas, terbukti bahawa COVID-19 merupakan bencana yang memberi kesan besar kepada pendapatan sesetengah individu yang pada asalnya berharta, kemudian dengan serta merta menjadi miskin. Mereka ini digolongkan di kalangan asnaf fakir miskin menerusi bantuan zakat. Dalam kes yang seperti ini, terdapat satu hadith yang membicarakan mengenainya iaitu halal bagi golongan seperti ini untuk memohon dan menerima bantuan zakat. Hadith tersebut berstatus sahih yang boleh dijadikan hujah dalam hukum hakam. Oleh yang demikian, institusi yang menguruskan dana zakat negeri, perlu merancang satu peruntukan tabung khas untuk situasi di luar jangka dengan tujuan membantu mereka yang terjejas teruk akibat bencana yang menimpa. Tabung khas itu boleh diambil daripada lebihan dana zakat yang tidak teragih, juga tidak dihabiskan pada tahun semasa untuk tujuan simpanan atau pelaburan. Apabila hal ini dapat dilakukan, maka ianya dapat merealisasikan kehendak hadith yang memperuntukan dana bantuan kepada golongan yang terjejas teruk akibat sesuatu bencana yang menimpa mereka.

RUJUKAN

- ‘Abd al-Ghani Bin ‘Abd al-Wahid Bin ‘Ali Bin Surur al-Maqdisi al-Jama’ili al-Dimashqi al-Hanbali Abu Muhammad Taqi al-Din (2009), *Umdah al-Ahkam al-Kubra*. Al-Riyad: Maktabah al-Ma’arif.
- ‘Abd al-Rahman Bin ‘Ubaydillah Bin ‘Abd Allah Ibn Muhammad Abu al-Qasim al-Harabi al-Hurfi (2007), *al-Juz’ al-Awwal Min al-Fawa’id al-Sahah Wa al-Ghara’ib Wa al-Afrad*. (T.T.P.): al-Dar al-Athariyyah.
- ‘Iyad Bin Musa Bin ‘Iyad Bin ‘Amru al-Yahsabi al-Sabti Abu al-Fadl (1998), *Sharh Sahih Muslim Li al-Qadi ‘Iyad al-Musamma Ikmal al-Mu’lim Bi Fawa’id Muslim*, j. 3. Misr: Dar al-Wafa’.
- Abu ‘Abd Allah Ahmad Bin Muhammad Bin Hanbal Bin Hilal Bin Asad al-Shaybani (2001), *Musnad al-Imam Ahmad Bin Hanbal*, j. 34. (T.T.P.): Mu’assasah al-Risalah.
- Abu ‘Abd Allah Muhammad Bin ‘Ali Bin ‘Umar al-Tamimi al-Maziri al-Maliki (1988), *al-Mu’lim Bi Fawa’id Muslim*, j. 2, c. 2. Al-Jaza’ir: al-Dar al-Tunisiyyah Li al-Nashr.
- Abu ‘Abd al-Rahman Ahmad Bin Shu’ayb Bin ‘Ali al-Khurasani (2001), *al-Sunan al-Kubra*, j. 3. Beirut: Mu’assasah al-Risalah.
- Abu al-Hasan al-Sindi (2010), *Fath al-Wadud Fi Sharh Sunan Abi Dawud*, j. 2. Misr: Maktabah Linah.
- Abu Bakr Bin Abi Shaybah ‘Abd Allah Bin Muhammad Bin Ibrahim Bin ‘Uthman Bin Khawasti al-‘Abasi (1409H), *al-Kitab al-Musannaf Fi al-Ahadith Wa al-Athar*, j. 2. Al-Riyad: Maktabah al-Rushd.
- Abu Bakr Muhammad Bin Ishaq Bin Khuzaymah Bin al-Mughirah Bin Salih Bin Bakr al-Salmi al-Naysaburi (t.t.), *Sahih Ibn Khuzaymah*, j. 4. Beirut: al-Maktab al-Islami.
- Abu Bakr Muhammad Bin Ishaq Bin Khuzaymah Bin al-Mughirah Bin Salih Bin Bakr al-Salmi al-Naysaburi (t.t.), *Sahih Ibn Khuzaymah*, j. 4. Beirut: al-Maktab al-Islami.
- Abu Dawud Sulayman Bin al-Ash’ath Bin Ishaq Bin Bashir Bin Shaddad Bin ‘Amru al-Azdi al-Sijistani (t.t.), *Sunan Abi Dawud*, j. 2. Beirut: al-Maktabah al-‘Asriyyah.
- Abu Muhammad ‘Abd al-Haq Bin ‘Abd al-Rahman al-Ishbili (1999), *al-Jam’ Bayn al-Sahihay* j. 2. Al-Riyad: Dar al-Muhaqqiq Li al-Nashr Wa al-Tawzi’.
- Abu Muhammad ‘Abd Allah Bin ‘Abd al-Rahman Bin al-Fadl Bin Bahram Bin ‘Abd al-Samad al-Darimi al-Tamimi al-Samarqandi (2000), *Musnad al-Darimi al-Ma’ruf Bi Sunan al-Darimi*, j. 2. Al-Mamlakah al-‘Arabiyyah al-Su’udiyyah.
- Abu Muhammad al-Husayn Bin Mas’ud Bin Muhammad Bin al-Farra’ al-Baghawi al-Shafi’i (1983), *Sharh al-Sunnah*, j. 6, c. 2. Beirut: al-Maktab al-Islami.
- Abu Muhammad Mahmud Bin Ahmad Bin Musa Bin Ahmad Bin Husayn al-Ghaytabi al-Hanafi Badr al-Din al-‘Ayni (2008), *Nakhb al-Afkar Fi Tanqih Mabani al-Akhbar Fi Sharh Ma’ani al-Athar*, j. 8. Qatar: Wizarah al-Awqaf Wa al-Shu’un al-Islamiyyah.
- Abu Sulayman Hamd Bin Muhammad Bin Ibrahim Bin al-Khattab al-Busti al-Ma’ruf Bi al-Khattabi (1932), *Ma’alim al-Sunan Wa Huwa Sharh Sunan Abi Dawud*, j. 2. Halab: al-Matba’ah al-‘Ilmiyyah.
- Ahmad Bin al-Husayn Bin ‘Ali Bin Musa al-Khusrawjirdi al-Khurasani (2003), *al-Sunan al-Kubra*, j. 7, c. 3. Beirut: Dar al-Kutub al-‘Ilmiyyah.
- Al-Husayn Bin Mahmud Bin al-Hasan Muzhir al-Din al-Zaydani al-Kufi al-Darir al-Shirazi al-Hanafi al-Mashhur Bi al-Muzhiri (2012), *al-Mafatih Fi Sharh al-Masabih*, j. 2. Al-Kuwaytiyyah: Dar al-Nawadir.
- Al-Husayn Bin Muhammad Bin Sa’id al-La’i al-Ma’ruf Bi al-Maghribi (2003), *al-Badr al-Tamam Sharh Bulugh al-Maram*, j. 4. (T.T.P.): Dar Hajar.
- Al-Nawawi (t.t.), *al-Majmu’*, j. 6. Kaherah: Maktabah al-Imam.
- Al-Qadi Nasir al-Din ‘Abd Allah Bin ‘Umar al-Baydawi (2012), *Tuhfah al-Abrar Sharh Masabih al-Sunnah*, j. 1. Al-Kuwayt: Wizarah al-Awqaf Wa al-Shu’un al-Islamiyyah.
- Al-Qaradawi (1973), *Fiqh al-Zakah*, j. 2, edisi ke-2. Beirut: Mu’assasah al-Risalah.
- Al-Shaykh ‘Abd al-‘Aziz Bin ‘Abd Allah al-Rajhi (2018), *Tawfiq al-Rabb al-Mun’im Bi Sharh Sahih al-Imam Muslim*, j. 3. (T.T.P.): Markaz ‘Abd al-‘Aziz Bin ‘Abd Allah al-Rajhi.
- Al-Shaykh Khalil Ahmad al-Saharanfuri (2006), *Badhl al-Majhud Fi Hill Sunan Abi Dawud*, j. 6. Al-Hind: Markaz al-Shaykh Abi al-Hasan al-Nadwi Li al-Buhuth Wa al-Dirasat al-Islamiyyah.

- Mahmud Muhammad Khitab al-Subki (1353H), *al-Manhal al-'Adhb al-Mawrud Sharh Sunan al-Imam Abi Dawud*, j. 9. Al-Qahirah: Matba'ah al-Istiqamah.
- Majd al-Din Abu al-Sa'adat al-Mubarak Bin Muhammad Bin Muhammad Bin Muhammad Ibn 'Abd al-Karim al-Shaybani al-Jazari Ibn al-Athir (2005), *al-Shafi' Fi Sharh Musnad al- Shafi' i Li Ibn al-Athir*, j. 4. Al-Riyad: Maktabah al-Rushd.
- Muhammad Bin 'Abd Allah al-Khatib al-'Umari Abu 'Abd Allah Wali al-Din al-Tibrizi (1985), *Mishkat al-Masabih*, j. 1, c. 3. Beirut: al-Maktab al-Islami.
- Muhammad Bin Hibban Bin Ahmad Bin Hibban Bin Mu'adh Bin Ma'bad al-Tamimi Abu Hatim al-Darimi al-Busti (1988), *al-Ihsan Fi Taqrib Sahih Ibn Hibban*, j. 8. Beirut: Mu'assasah al-Risalah.
- Muhammad Bin Ibrahim Bin Ishaq al-Salmi al-Munawi Thumma al-Qahiri al-Shafi'i Sadr al- Din Abu al-Ma'ali (2004), *Kashf al-Manahij Wa al-Tanaqih Fi Takhrij Ahadith al- Masabih*, j. 2. Beirut: al-Dar al-'Arabiyyah Li al-Mawsu'at.
- Muhammad Bin Isma'il Bin Salah Bin Muhammad al-Hasani al-Kahlani Thumma al-San'ani Abu Ibrahim 'Izz al-Din al-Ma'ruf Ka Aslafihi Bi al-Amir (t.t.), *Subul al-Salam*, j. 1. (T.T.P): Dar al-Hadith.
- Muhyi al-Sunnah Abu Muhammad al-Husayn Bin Mas'ud Bin Muhammad Bin al-Farra' al- Baghawi al-Shafi'i (1983), *Sharh al-Sunnah*, j. 6. Beirut: al-Maktab al-Islami.
- Musa Shahin Lashin (2002), *Fath al-Mun'im Sharh Sahih Muslim*, j. 4. (T.T.P): Dar al-Shuruq.
- Muslim Bin al-Hajjaj Abu al-Hasan al-Qushayri al-Naysaburi (t.t.), *al-Musnad al-Sahih al- Mukhtasar Bi Naql al-'Adl Ila Rasulillah Sallahu 'Alayh Wa Sallam*, j. 2. Beirut: Dar Ihya' al-Turath al-'Arabi.
- Shihab al-Din Abu al-'Abbas Ahmad Bin Husayn Bin 'Ali Bin Ruslan al-Maqdisi al-Ramli al- Shafi'i (2016), *Sharh Sunan Abi Dawud*, j. 7. Misr: Dar al-Falah Li al-Bahth al-'Ilmi Wa Tahqiq al-Turath.
- Sulayman Bin Ahmad Bin Ayyub Bin Mutir al-Lakhmi al-Shami Abu al-Qasim al-Tabrani (1985), *al-Rawd al-Dani (al-Mu'jam al-Saghir)*, j. 1. Beirut: al-Maktab al-Islami.
- Sulayman Bin Ahmad Bin Ayyub Bin Mutir al-Lakhmi al-Shami Abu al-Qasim al-Tabrani (1994), *al-Mu'jam al-Kabir*, j. 18. Al-Riyad: Dar al-Sami'i.
- Muhammad Syarif Omer dan Mohd Sadat Mahmud (2019). Analisis Garis Panduan Agihan Zakat (*Hadd al-Kifayah*) Majlis Agama Islam Dan Adat Melayu Terengganu (MAIDAM). *Jurnal Pengurusan Dan Penyelidikan Fatwa*, vol. 17. No. 2. 2019 (*Edisi Khas*), 7-25. Artikel Penuh: <https://www.sinarharian.com.my/article/86984/KOLUMNIS/Solusi-bencana-Covid-19>, diakses pada 22 September 2020.
- Astroawani. 2020. COVID-19: Adakah Alam Sedang Bertindak Balas Terhadap Kealpaan Manusia? <https://www.astroawani.com/berita-malaysia/covid19-adakah-alam-sedang-bertindak-balas-terhadap-kealpaan-manusia-236990>, diakses pada 22 September 2020.
- BeritaHarian Online. (2020, Jun 4). AirAsia tamatkan perkhidmatan 300 pekerja. Diakses pada September 20, 2020 daripada <https://www.bharian.com.my/bisnes/korporat/2020/06/696456/airasia-tamatkan-perkhidmatan-300-pekerja>
- BeritaHarian Online. (2020, Mac 6). RM100 juta kerugian, susulan larangan umrah. Diakses pada September 20, 2020 daripada <https://www.bharian.com.my/berita/nasional/2020/03/662683/rm100-juta-kerugian-susulan-larangan-umrah>https://ms.wikipedia.org/wiki/Pandemik_COVID-19#Epidemiologi, diakses pada 22 September 2020. diakses pada 23 September 2020.
- Jabatan Haji, Wakaf dan Zakat (JAWHAR), Manual Pengurusan Agihan Zakat, 2007.
- Jabatan Perangkaan Malaysia, 2020. Laporan survei khas kesan Covid-19 kepada ekonomi dan individu (pusingan 1). Kementerian Kesihatan Malaysia (2020). Laman FB Rasmi (<https://www.facebook.com/kementeriankesihatanmalaysia>).
- Lembaga Zakat Selangor, Majlis Agama Islam Selangor. (2020). 29,000 Penerima Bantuan Khas COVID-19 LZS Terima Manfaat Agihan Zakat. <https://www.zakatselangor.com.my/terkini/29000-penerima-bantuan-khas-covid-19-lzs-terima-manfaat-agihan-zakat/>, diakses pada 22 September 2020.
- Majlis Agama Islam Wilayah Persekutuan. (2020). Laman Web Rasmi. Maklumat Bantuan Kecemasan. <https://www.maiwp.gov.my/i/index.php/en/maklumat-bantuan-kecemasan-musaadacovid19-maiwp>, diakses pada 22 September 2020.
- Perdana Menteri Malaysia, 2020. Pengumuman lanjutan moratorium dan bantuan bank bersasar bertarikh 29 Julai 2020
- Perutusan Khas YAB Perdana Menteri Mengenai Covid-19 bertarikh 16 Mac 2020 Perutusan Perdana Menteri Malaysia berkaitan penularan jangkitan penyakit Coronavirus 2019 (Covid-19) di Malaysia bertarikh 13 Mac 2020
- Utusan Borneo Online. 2020. COVID-19: Malaysia Hadapi Bencana Luar Biasa. <https://www.utusanborneo.com.my/2020/04/24/covid-19-malaysia-hadapi-bencana-luar-biasa>, diakses pada 22 September 2020.
- Zakat Pulau Pinang. (2020). Pakej Bantuan Khas Zakat COVID-19 Fasa 2. <https://www.zakatpenang.com/zpp/index.php/agihan/pakej-bantuan-khas-zakat-covid-19-fasa-2>, diakses pada 22 September 2020.

THE INNOVATIONS OF HIBAH AS AN INSTRUMENT OF ISLAMIC FINANCE AND ISLAMIC ESTATE MANAGEMENT IN MALAYSIA

Ahmad Khilmy Abdul Rahim, Azizi A
Abu Bakar, Mohd Murshidi Mohd Nor & Alias Mat Nor

Islamic Business School, College of Business Universiti Utara Malaysia

Abstract

The application of hibah as an instrument in estate management is gaining popularity among the Muslim community in Malaysia. "Hibah is a unilateral contract" that elevate welfare and charity. Islamic financial institutions in Malaysia, including Islamic banks and Islamic wealth institutions apply varieties of hibah instruments in the products offered by them. Hibah is a cooperating shariah contract in the Malaysia's Islamic banking and financial framework. The aim is to incentivize clients for storing their cash into the institution as well as remunerate for clients to pay their financing by agreeing planned. The use of hibah is based on the stated principles and objectives of the "Shariah Advisory Council (SAC) of Bank Negara Malaysia". Nowadays, the hibah instrument has been applied in various forms by Islamic financial institutions especially in Malaysia. This paper discusses and analyzes in general the application of contemporary forms of hibah such as Trust Hibah (Hibah Amanah), Conditional Hibah (*Hibah Mu'allaqah*), Hibah with consideration (*Hibah Bi al-Thawab*), hibah in saving account (*Wadiah*) and rental (*al-Ijarah*) accounts and hibah in *Takaful benefit*.

Key words : Innovations, Hibah, Islamic banking and finance, Islamic estate management

1.0 Introduction

Wealth is one part of sustenance given by Allah to all mankind. Islam permits people to accumulate wealth as long as it is Shariah compliant, not from doubtful source and meets the standard criteria of halal. Acquiring Islam must be in completely fair way, must be overseen in a profoundly capable way to advantage all and must not divert Muslims in any manner from their faith confidence in Allah S.W.T. Therefore, all muslims is considered as a "trustee" and is accountable on wealth creation, wealth accumulation and wealth distribution. Simultaneously, the money acquired must always be invested in the right as stated by Allah S.W.T in "Surah Al-Baqarah, verse 261 and 274 which mean": "*The parable of those who spend their substance in the way of Allah is that of a grain of corn: it growth seven ears, and each ear Hath a hundred grains. Allah giveth manifold increase to whom He please: And Allah care for all and He knows all things. (2:261)*" "*Those who (in charity) spend of their goods by night and by day, in secret and in public, have their reward with their Lord: on them shall be no fear, nor shall they grieve. (2:274)*".

Basically, there are four instruments in wealth planning in Islam; namely *faraid*, *wasiyyah*, hibah and waqf (Azman, 2013). Faraid known as Islamic inheritance dissemination strategy to legitimate beneficiaries after the death of a Muslim based on the Islamic law (Ab Aziz & Nordin, 2015). It plays a very important role in wealth planning in Islam. It is important that the "Prophet S.A.W" exhorted us not only to learn but also to teach the knowledge of *faraid* to others. He furthered declared that the knowledge of faraid to be half of knowledge and the first knowledge to be uplifted. Related to this, Prophet S.A.W said in a hadith (Al-Hakim, 1998) which means: "*Learn the Qur'an and teach it to the people, acquire the knowledge of faraid (laws of estate distribution) and teach it to the people, for I am a person who has to depart this world and the knowledge will be taken away and turmoil will appear to such an extent that two people will not agree in regard to a case of estate distribution and find none who would decide between them*"

The second instrument of Islamic wealth planning is *wasiyyah* or testamentary disposition. A *wasiyyah* or will means an *iqrar* individual's favor of or benefiting from his property during his lifetime For charitable activities or for some other cause that is morally acceptable under Islamic law after his death (Muslim Wills (Selangor) Enactment 1999, s. 2(1). Waqf, another instrument of Islamic wealth planning implies charities that have persistent and consistent, so that people will profit from them for decades. This mean that waqf property is kept intact and only the residual

income that is derived from it is used for the specific purpose (Azman, 2013).

Another instrument is hibah, which is considered as one of the dominant instruments in the management of Islamic estate. This is a method of conferring a property to another contingent and effective immediately in the life of the donor (*al-wahib*). The use of hibah in the management of estate is gaining popularity among the Muslim community in Malaysia because of its unique characteristics such as it ensures that the specific beneficiaries will be the recipient of the hibah, the assets are also certain and determined and it does not fall under faraid distribution (Amir, 2014). Hibah is a one-party (unilateral) and charity (*tabarruat*) contract. In the Islamic financial system, Islamic banking institutions generally adopt the concept of hibah to reward *wadi'ah* and *qard* depositors. There is also a practice of granting a hibah to a client in certain cases such as a hibah to a customer making a payment on a regular basis. Takaful companies also practise the giving of hibah benefits to their clients. This paper focuses the discussion of hibah from the perspective of fiqh and its application in several Islamic banking and finance institutions as well as an Islamic estate management product in Malaysia.

2.0 The concept of Hibah

Hibah is one of the contracts under the classification of *tabarru'at* (charity) other than *was'iyah*, *waqf*, *'ariyah* and *qard*. *Tabarru'at* means a contract which amplifies property or its benefit to others, promptly or within the future, without craving a stipend and with the purposeful of doing a devout deed. In other words, *tabarru'at* are the acts of piety and charity (Al-Mausu'ah Al-Fiqhiyyah, 1988). The spirit in *tabarru'at* is to spread the wealth and help others out of love and not of selfish gain.

Literally, hibah is an Arabic term which comes from the root word "*wahaba*" means expressing a benefit to others without any expected possibility of return (Ibn Manzur, 2003, Al-Qunawi, 2004). Technically, the Hanafi and the Shafi'i jurists define hibah as "a voluntary contract that results in uncompensated ownership transfer between living individuals". A more specific definition is provided by the Hanbali jurists that hibah could be a contract stated by a qualified party to exchange possession and transferred properties without remuneration. The properties may be specified or unspecified, the offered can be formed as a gift conventionally, and the wording of the contract must indicate whether it is a blessed gift or shifting, etc (Al-Zuhaily, 2007). These definitions concentrate on people as benefactors. This was the norm amid the early times but in the modern time rather than people, organizations and institutions play a vital part as givers as well. (*al-wahib*).

According to the jurists of "Shafi'i school" of thought, the term hibah can be viewed from two perspectives. From a general perspective hibah is a gift that includes rewards (giving with the intention of glorifying someone), *alms* (giving in hope of Allah's reward) and *ibra'* (debt relief by the creditor). The second part refers to a specific one which means the giving of one's possession to another without repayment and subject to certain rules and regulations (Al-Nawawi, 1985; Al-Qalyubi wa 'Umayrah, n.d.). In more detail, hibah is known as an act of a person who gives away property to another entity or another without intentional return (*iwadh*) amid lifetime, not anticipating reward in the hereafter or seeking people's magnificence by using the terms of *ijab* and *qabul*. The gift during lifetime by the donor (*al-wahib*) may also include other forms of gifts such as *hadiyyah* and *sadaqah* (al-Nawawi, 1985).

Some scholars differentiate the terms *hibah*, *hadiyyah* and *sadaqah*. Hibah is to willingly give without a slight expectation to receive anything in return; *hadiyyah* is a gift to another person for a particular reason or commemoration, courtesy or honour, while *sadaqah* is a type of gift that is given for the sake of "Allah S.W.T" or what is given with the desire of obtaining recompense from "Allah S.W.T" (Amir, 2014). In short, based on the above definitions, we can conclude that hibah should have the following characteristics:

- i. a contract of transferring the ownership of property to another
- ii. the hibah asset is a real property (*ain mal*) not a debt or benefit.
- iii. it is made without any recourse or consideration (*iwadh*)
- iv. it is effective during the life of the donor (*al-wahib*).
- v. it is by own deed and voluntary (without coercion by anyone)
- vi. it is not intended to earn any reward or honoring certain people.

Shari'ah promotes the practice of hibah among Muslims. The law of granting a hibah in all its forms including gifts and *sadaqah* is recommended based on the arguments of the Quran, sunnah and ijmak (al-Zuhaily, 1989). Verses of the Al-Quran that showed of hibah "Allah s.w.t." has mentioned:

"But if they give up willingly to you anything of it, then take it in satisfaction and ease."

"(Surah An-Nisa: verse 4)"

The above verse argues that the gift a wife makes from her dowry to her husband is permissible and it is considered by the majority fuqaha as a hibah (al-Qurtubi, 2002). The Prophet S.A.W encouraged people to mutually exchange gifts among one another. He said in a hadith :

“Mutually exchange gifts, you will love one another

(al-Bukhari, 1987, 4/174)

The above hadith clearly shows the encouragement of the “Prophet S.A.W” that the exchange of gifts with each other can strengthen their fellowship and friendship. This encouragement clearly indicates the permissibility of making hibah. According to Ibn Rusyd (1988), the encouragement to make hibah has also been acknowledged by ijmak as it falls into the category of charity.

3.0 The practice of Hibah among early Muslim community in Malaysia

The concept of hibah as it is known and practiced today is already well known among the Muslim community in Malaysia in the past. The practice of distributing property and estate especially to the family members and relatives has long existed despite not being as systematic in practice as today. Malay community in the past practised hibah in the form of helping their children to begin a married life. In this case, the parents or mother will help to provide their children’s wedding needs such as dowry, wedding ceremony as well as lands and houses. The hibah (gifts and help by parents) was seen as an effort by the parents to ensure the stability of the new couple's life after living apart from them (David J. Banks, 1976).

The custom (*urf*) of giving gifts to the brides, hosted a ceremony to celebrate the birth of a new member in the family and also in circumcision ceremony was the custom prevailing among the early Malay Muslim community in our country. The term used by muslim scholars to describe such a gift is *al-nuquth*. It is a gift to a bride and groom or any gift in conjunction with certain events namely moving to a new house with intention of receiving a reward from the recipient. The custom of *al-nuquth* is associated with the gift given in conjunction with the wedding ceremony which obliged the recipient to repay the gift (Al-Kasani, 2003). The gifts at the circumcision ceremony was also a custom passed down through generations among Muslim community in Malaysia and even among the Arabs. The practice of donating money or gifts of food ingredients such as oil, sugar, rice, etc among the locals has become customary habits and practices in the community for a long time (Mohd Rofaizal et.al, 2017).

The discussion above indicates that hibah (gift) is a practice that has long been practiced and has become an important estate planning mechanism among the Muslim community in Malaysia. However, recent developments show that the principles of hibah today is not merely seen in terms of 'giving' in families only, but it is a concept in fiqh that is applied in matters that may be considered as commercial. Currently, hibah is broadly utilized within the advancement of Islamic financing items. A few of the modern applications of hibah have been subject to the criticism as to whether they meet the objective of the contract. In this regard, hibah nowadays applies not only in Islamic banking industry, but in the takaful, capital markets and Islamic estate planning industries too.

4.0 The application of Hibah in Islamic banking, Takaful and Islamic estate industries.

Hibah is considered as “supporting shari’ah concepts” in the resolutions of the “Shari’ah Advisory Council (SAC) of Bank Negara Malaysia”. Hibah usually serves as a selling point for certain products offered by Islamic banks in Malaysia (Nasrul Hisyam, 2010).

4.1. Hibah in Islamic banking products

Originally hibah was implemented as a unilateral contract. At the other hand, the activities of Islamic banks apply hibah either as a "supporting principle" or only in contracts where the institutions can make profit on it. The change from the initial hibah to current hibah implementations must ensure it will does not hinder the expansion of charitable acts. The discussion below is about the application of hibah as a supporting contract in Islamic banks in Malaysia .
i. *Al-Ijarah Thumma Al-Bay'* (AITAB)

The term “*al-Ijarah Thumma al-Bay'* (AITAB)” is a combination of two contracts namely *al-ijarah* (rental) and *al-bay'* (sale). The word *al-ijarah* is derived from the word *al-ajr* which means reward or remuneration (Ismail, 1997). Technically, although the definitions by the jurists were different in terms of words and sentences but it has similarities in meaning. *Al-ijarah* is defined as “a contract of exchange to take possession of some utility or services for payment (al-Jurjani, 1988, al-Syarbasi, 1981). It indicates the sale of a benefit, use or service for a price that can be either fixed or floating. The most important element in the meaning of *al-ijarah* is benefit. According to the majority of jurists, *al-ijarah* applies more to benefits rather than the object itself. This is because the main purpose

of *al-ijarah* is to obtain its benefits instead of owning the object (al-Ansari, n.d). Al-Bay 'means "exchange of property with property in a certain way" (Al-Ansari, n.d).

By definition, AITAB refers to lease or hire or rent ending with purchase (Khair *et al.*, 2008). In Malaysia, AITAB is also known as “*al-Ijarah wal-Iqtina* or *al-Ijarah Al-Muntahiyah bi al-Tamleek*”. This incorporates a lease and sale deal in one trading agreement, but the deals must be operated separately: first, the leasing agreement would perform that the lessee must pay the lessor a recurring rent over a defined term. Second, upon expiry of the renting period, the hirer has the choice to enter into a moment contract to buy the merchandise from the proprietor at a upon El-Din and Abdullah, 2007).

Islamic banks in Malaysia offers hibah in “*al-Ijārah thumma al-Bay*’ contract (AITAB)” as one of the incentive to the customers to pay their monthly rent based “prescribed schedule”. Islamic banks are providing hibah to customers and they will make monthly rents payments as agreed date in the first year without any interruption. 1% of the financing amount will be credited into the eligible customers account on the 13th month (Bank Negara Malaysia, 2007). The basis of this SAC resolution was exchanging gift is strongly recommended in the Qur’an and hadith. This is definitely sees as a good deed.

ii. *Wadi’ah Yad Dhamanah* (saving account)

The term *wadiyah* is derived from the verb “*wada’a*, which means to leave, lodge or deposit” (Al-Farabi, 1987). Technically, according to Shafi’i scholars, *wadiyah* is clearly provided in keeping ownership of respectable private goods in particular way (Syarbini, t.t). Sabiq (1999) stated that *wadiyah* is keeping something or known as safeguard, and deliver back on the request. “*Wadiyah yad dhamanah* is the combination between safe-keeping (*wadiyah*) and guarantee (*dhaman*)”. This type form of deposit facility is commonly used in the framework of Islamic banks, deposits are the main sources. The few features: the safekeeper is entitled to trade or some other reason using the deposit capital. He is thus entitled to truly benefit from the use of the property and often he is completely liable for any damage. (ISRA, 2013).

The element of guarantee (*dhaman*) is significant because of the bank is permitted to use the stores at its own risk. In any case in the event that the investors inevitably choose to pull back their cash; the bank has to guarantee that the money is made accessible upon request. The profit from the use of the deposit funds goes to the bank alone. The bank can however freely opt to share the income received with the depositors as a means of flexibility in the form of “discretionary hibah”. (Antonio, 2001). The Islamic banks in Malaysia give hibah to the *wadi’ah* depositors as an indicative appreciation for their contribution in the institutions. This hibah is “permissible” with a condition that this contract procedure should not similar with *wadi’ah* deposit contract.

iii. *Qard* contract (saving account)

Qard is to trade ownership of possession in exchangeable wealth to an individual upon whom it is official to return wealth comparable to it. The purpose of *qard* is to provide one who can benefit from this act with the wealth or properties upon loan. By offering, the receiving party hires and uses it in fulfilment of its purposes, and then returns the equal interest (Irsyid, 2007). In *qard* structure applies by Islamic banks, the depositor is deemed as a lender to the bank and the bank guarantee in return even if there is negligence or loss of wealth (ISRA, 2013). In this case, the depositors earn hibah from the bank as a lender. The SAC resolution indicated this practice as “permissible” with the condition that such practice (give hibah) should not become typical and similar as a condition in the *qard* contract.

4.2 Conditional Hibah (*Hibah mu’allaqah*)

A conditional hibah is a grant that is required (suspended) by the occurrence of something. Based on this concept, grant is only implemented when the conditions are set. There are two views among the scholars in regard with conditional hibah:

i. Shafi’i scholars, a view from Hanbali scholars and Zahiri: hibah with any future terms or conditions is unlawful (invalid) hibah could be a contract that will ended up invalid since of jahalah (ignorance). Thus, hibah must be unconditionally (to certain occasion in future) and typically comparative to the restriction of a contractual sale deal (to some event in the future); (Al-Syarbini, n.d.). According to Ibn Qudamah (1997), “hibah contract which is conditional to terms is void because hibah is a giving of ownership (transfer of ownership) to a specific beneficiary in his life, thus, hibah cannot be conditional like sale contract (which cannot be conditional)”.

ii. Maliki and Hanafi scholars and some of Hanbali scholars specifically the opinion of “Ibn Taimiyah and his disciple Ibn al-Qayyim”. : Hibah with conditions is valid. There is a legal maxim attributed to the Hanafis which

goes as follows: "المواعيد بصورة التعاليق تكون لازمة" which means "promises in the form of *ta'liq* (condition) is binding" (Ibn Nujaym, 1999). According to school of thought Maliki, hibah with conditions to be fulfilled in future is valid due to the reason that uncertainty (*gharar*) does not influence the legitimacy of hibah contract. Based on "Imam Malik" stated, "whoever makes commitment of doing any good it is binding for him to execute except at death or insolvent" (al-Qarafi, 1998; al-Kharshi, 1997).

Among the products of Islamic banking and finance that operate using conditional hibah (*hibah mu'allaqah*) are as below :

i. Sahabat Agro (AgroPrimaS) by Agro Bank

The Sahabat Agro instrument is a marketing program offered by Agrobank Malaysia that uses the Saving, Reference and Gain Reward concept for AgroPrimaS product. "AgroPrimaS is specially designed Term Deposit-i Account based on existing Agrobank's Term Deposit-i Account (FRIA-i)" that promoted under Sahabat Agro Program which applies *tawarruq* contract. Depositors of AgroPrimaS can earn reward (hibah by bank) by referring their suggested customers to the Bank with certain conditions to be fulfilled. This product applies the Shariah concept *hibah mu'allaqah* or conditional hibah where the reward or grant will be given to a member who successfully meets the Bank's terms and conditions (<https://www.agrobank.com.my/product/sahabat-agro/> 25.4.2020). The basic requirements and conditions that members must adhere to in order to receive the reward (in the form of a hibah) are :

- i. Members must maintain at least RM 500.00 in AgroPrimaS Term Deposit Account throughout membership (12 months).
- ii. Members shall refer the suggested customer to Agrobank and the customer must open an AgroPrimaS Term-Deposit Account-i with a minimum deposit of RM 500.00.
- iii. Members are entitled to gain reward (hibah) for each referral (new customer) in their network as long as the member and referral complies with the terms and conditions of the Sahabat Agro Program.

This product offers by Agrobank after obtaining the approval of Shariah advisors of the bank in term of conditions and operations

ii. Takaful benefit

family takaful offered mutual interest and each participant's responsible to contribute in the investment, or known as claim or compensation from the risk account pooled from participant's *tabarru'* portion (Bank Negara Malaysia, 1984). Takaful proceeds are typically correlated with participant death and takaful plan maturity. If the participant still alive after the takaful plan maturity, the participant obtained the takaful benefit eventually and it will happen the other way round if the participant dies before the issuance of the takaful certificate, the person named by the participant shall receive takaful benefit. (Md. Habibur Rahman, et.al, 2019).

According to IFSA, Schedule 10, Para 1 & 2 (2013), The main issue regarding to the appointment is the status of the nominee are whether he is the sole beneficiary or simply the executor. In the event if the nominee happen to be as an executor, they are responsible to ensure takaful benefits will only receive upon maturity according to the pertinent and appropriate legacy laws. When the candidate is named as the primary beneficiary, the takaful applicant, under the principle of conditional hibah (gift), she / he allowed to accept the takaful benefit. The condition of this hibah for the candidate to become the primary recipient of the takaful benefits happen only when the applicant dies before the nominee and before the maturity takaful plan. This will mean that the takaful benefits would not be contained in the candidate's properties, but would instead be the applicant's sole property. (Mohd Kamil & Joni, 2017).

Based on the analysis, the researcher concludes that the practise of *hibah mu'allaqah* to the beneficiaries in takaful benefits conjuncted to the death of the takaful participant is similar to the concept of *hibah ruqba* as discussed by fuqaha in classical fiqh books. *Ruqba* is a gift contract limited to the lifetime of sender or receiver. Anyone dies early will benefit contribution to the other side (Amir, 2014). In truth, *ruqba* means holding up for the other to die. The implementation of hibah umra and ruqba in the takaful industry is approved by some of the scholars today (Al-Quradaghi, 2004).

iii. Shariah-compliant Retirement Annuity Plan

Annuities have been viewed as financial back-up measures during retirement age, and as a way of reducing the chance of mortality when a person loses their savings. The annuitant tries to secure stable retirement payouts by exchanging liquid lump amounts in exchange for a sequence of installments before he / she dies (Soulhi, 2017). Annuity (a Latin word meaning yearly) is a contract in which an insurance/ takaful company agrees to provide the

customer/ contributor with a lifetime income, in return for the premiums paid at once (Mohammad Mahbubi et.al, 2014). Annuity Plan would be retirement product is the most common mechanisms for managing age-related risks, known as longevity risk (Ismail.F, 2016). The annuities effectively have a constant income of a fixed amount for the entire annuity period.

A few entities such as Amanah Raya proposed a sharia-compliant “Public Mutual Private Retirement Scheme (PRS)” that contributed in both sukuk and stock investments as a technique to revitalize in returns in stock market instability. HSBC Amanah has given a non-pledge annuity up to age 75 (<https://cdn.hsbcamanah.com.my/takaful-retirement-plan-regular.pdf/> 30 April 2020). In general, this instrument was marketed under the PRS which is permitted to provide insurance firms, takaful operators, banks and unit trusts (Soulhi, 2017).

Shari’ah compliant annuity framework model is based on the “wakalah (agency) and hibah mu’allaqah (conditional gift)” principles. The wakalah concept focuses at managing and investing an annuity fund (wakalah bil istismar), thus accrued amounts of contributions and investment profits will be deposited in *tabarru*'s fund, and then process of annuity payment through *hibah mu’allaqah* will begin. To meet the hibah deal, the participants must bring their accrued sums of donations and benefit profits from investment into *tabarru*' fund at wakalah maturity contract. Then all hibah contract applicants have the right to obtain the rewards of the *tabarru* contract, which is the monthly revenue source before their death. (Mohammad Mahbubi et.al, 2014).

4.3 Hibah trust (Hibah amanah)

Hibah trust is a combination of hibah and trust features itself. In common, it could be a blessing from the benefactor to the recipients amid his lifetime, which the resources will be held by a designated trustee for a certain period of time and can as it were be transferred to the recipients after the donor’s demise in accordance to the parties’ agreement in the Trust Deed (Alias, 2017). The major difference between direct hibah and hibah trust is that the possession of the asset is fully passed to the hibah recipient in a direct hibah; thus, the beneficiary no longer has any interest or privileges towards the asset. In comparison, in hibah trust, even if the asset has been passed to the beneficiaries either legitimately or constructively, the donor will still receive the asset's benefits after receiving the beneficiaries' consent (written in a separate agreement) (Nazrul et.al, 2016).

In Malaysia, “hibah trust, or often referred as hibah amanah, trust hibah or hibah harta” has recently gained considerable prominence in Islamic estate planning since Hibah Amanah was introduced by Permodalan Nasional Berhad, a substantial Malaysian fund management company through Amanah Saham Nasional Berhad (ASNB). By this concept, its members can hibah their investment under ASNB products to their beneficiaries. ASNB becomes the appointed trustee in the structure of hibah trust by PNB (Amir, 2014). Other hibah trust products introduced in Malaysia include:

- i. Pri-Hibah by CIMB-Principal Asset Management Berhad
- ii. Hibah Harta Trust by CIMB Islamic Berhad (2016)
- iii. Pri-Hibah (2016) by As-Salihin Trustee Berhad
- iv. Hibah Amanah Raya (2016) by Amanah Raya Berhad, and
- v. Hibah Amanah TH (2017) by Lembaga Tabung Haji.

4.4 Hibah with consideration (*Hibah bi al-Thawab*)

The use of *hibah mu’allaqah* in some of the products discussed above should be related to the discussion of *hibah bi al thawab* (hibah with consideration) which is a gift or grant that targets return (benefits). Al-Kharshi (w.d) defines “*hibah bi thawab*” as a contribution made to obtain future financial benefits. Generally they are of two views on the validity of “*hibah bi al-thawab*”. Firstly, *hibah bi al-thawāb* (gift with expected compensation) valid and effective; this view is agreed by majority of Muslim jurists from the four schools of thought, i.e. “Hanafi, Maliki, Shafi’i and Hanbali” (Al-Zuhaily, 1989). Secondly, is agreed by some Muslim jurists of the Shafi’i school that such form of hibah is null and void. The Shāfi’i school distinguished between known and unknown consideration (*thawab ma lum wa majhul*). If the factor is unknown they make the hibah deal. The Shāfiis hold two views in relation to the established concern. First conclusion it isn't allowed, since they clearly indicate a requirement to account for a known consideration restricts the initial purpose of hibah. Their second opinion coincides with the opinion they have given regarding unknown consideration (Al-Nawawi, n.d).

The researcher concludes that the modern applications of hibah mostly often under context of hibah with consideration (*hibah bi al-thawāb*) including the above mentioned products namely Sahabat Agro, takaful benefits and Shariah compliant retirement annuity plan. According to jurists, the implementation of *hibah bi al- thawab* would change the concept of *tabarru*' from the bilateral contract to the bilateral contract. In other words, if the gift is made in return for potential claims, then the gift ruling is equal to the selling principles (Muhammad, 2010). On

the other hand, some jurists conclude that hibah bi al-thawab is viewed as a unilateral contract with all its provisions and consequences, such as genuinely a gift, and is lawful.(Al-Qurrahdaghi, 2004).

5.0 CONCLUSION

Hibah is considered as a supporting contracts to major shariah contracts in the Islamic banking and financial system in Malaysia. The application of hibah in Islamic banking products is more about providing incentive to encourage and motivate customers to pay their monthly rent in compliance with the "prescribed schedule" or as a token of gratitude for their faith in the entities. Based on current practice of Islamic banks in Malaysia, hibah is applied in the products based on the contract of *wadi'ah yad al-dhamaanah*, *al-qardh* and *al-ijarah thumma al-bay'*. The application of *hibah mu'allaqah* (conditional hibah), *hibah umra* and *ruqba*, *hibah* trust and *hibah bi al-thawab* in Islamic finance and Islamic estate planning products such as the Sahabat Agro Programme, takaful benefits, Hibah Trust TH and PNB and Shariah-compliant Retirement Annuity Plan are the innovations in the practise of hibah currently. It is obvious the use of hibah variation forms may support the long and complicated strategies of inheritance prodedures, diminish regulatory costs and dodge legitimate hindrances. The practice of *hibah* also preserves several Islamic characteristics in terms of avoiding interruptions in the processes of distribution of property but there are still arguments and debate around this issue. In general, most of the contemporary scholars allow such practice as long as this does not infringe the original hibah concept.

REFERENCES

- Ab Aziz, M. R., & Nordin, N. I. (2015). Perception towards planning of waqf, wasiyyah and faraid in Islamic wealth distribution : Malaysian perspective. *Journal of Scientific Research and Development*, 2(12), 13–18
- Abdul Halim b Muhammad. (2006). *Undang-undang Mu'amalat dan Aplikasinya Kepada Produk-produk Perbankan Islam*. Petaling Jaya: Dasar Cetak Sdn. Bhd.
- Ahmad Yusuf. (1993). *Uqud al-Mu'awadat al-Maliyah fi Daw al-Ahkam al-Syariyyah al-Islamiyyah*. Kaheerah: Dar al-Saqafah.
- Al- Ansari, Zakariyya.(n.d). *Qalyubi wa Umairah 'ala Minhaj al-Talibin*. Al-Mansurah: Maktabah al-Iman.
- Al-Bukhari, Muhammad b Ismail al-. (1987). *Sahih al-Bukhari*.j.4. Beirut: Dar Ibn Katsir.
- Al-Farabi, Abu Nasr Ismail bin Hammad Al-Jauhary. (1987). *Al-Shahah Taj Al-Lughah Al- Arabiyah*. Dar al-Ilm: Beirut.
- Al- Fayyumi, Ahmad b Muhammad.(n.d). al-Misbah al-Munir. Kaheerah: Dar al-Maarif
- Al- Jurjani, Ali b Muhammad . (1988). *Kitab al-Ta'rifat*. Beirut: Dar al-Kutub al-Ilmiyyah.
- Al-Kharshi, Muhammad ibn Abdullah. (1997). *Sharh al-Kharshi ala Mukhtasar al-Khalil*. Beirut: Dar al-Kutub al-Ilmiyyah
- Al-Kasani, 'Ala' al-Din Abu Bakr bin Mas'ud.(2003). *Bada'i al-Sana'i fi Tartib al-Shara'i*, vol. 8, ed. 'Ali Muhammad Mu'awwad & 'Adil Ahmad 'Abd al-Mawjud. Beirut: Dar al-Kutub al-Ilmiyyah
- Al-Nawawi, Abi Zakariyya Mahy al-Din (1985). *Rawdhat al-Thalibin*, j.5 Beirut : al-Maktab al-Islami.
- Al-Nawawi, Muhyiddin Abu Zakariyya Yahya b Sharaf. (n.d). *Al-Majmu' Sharh al-Muhazzab*. Jeddah: Maktabah al-Irsyad.
- Al-Qarafi, Sihab al-Din. (1998). *Al-Furuq*. Beirut: Dar al-Kutub al-Ilmiyyah
- Al-Qunawi, Qasim Ibn 'Abd Allah. (2004). *Anis al-Fuqaha fi Ta'rifat al-Alfaz al-Mutadawilah bayna al-Fuqaha'*. (Beirut: Dar al-Kutub al-Ilmiyyah)
- Al-Qurrahdaghi, Ali Muhyiddin. (2004). *Al-Ta'min al-Islami, Dirasah Fiqhiyyah Ta'siliyyah*.Dar al-Basyair al-Islamiyyah.
- Al-Qurtubi, Abu Abdullah Al-Ansari.(2002). *Al-Jami' li Ahkam al-Quran*.j.5. Kaheerah : Dar al-Hadith.
- Sabiq, Al-Sayyid. (1999). *Fiqh al-Sunnah*. Mesir: Dar al-Fath lil 'Ilam al-Arabi.
- Al-Syarbasi, Ahmad.(1981). *Al-Mu'jam al-Iqtisadi al-Islami*. Mesir: Dar al-Jayl.
- Al-Syarbini, Syamsuddin Muhammad b Muhammad al-Khatib . (n.d). *Mughni al-Muhtaj*. Mesir: Al-Maktabah Al-Taufiqiyyah.
- Al-Syirazi, Abu Ishaq Ibrahim bin Ali bin Yusuf (1995). *Al-Muhazzab fi Fiqh al-Imam al-Syafie*. Beirut : Darul Kutub al-Ilmiyyah.
- Al-Zuhaili, Wahbah. (1989). *Al-Fiqh Al-Islami Wa adillatuhu*. Juz 5. Damsyiq : Dar al-Fikr.
- Al-Zuhayli, Wahbah. (2007). "Financial Transactions in Islamic Jurisprudence" in *Al-Fiqh al-Islami wa Adillatuh*, translated by Mahmoud A. El-Gamal. Beirut: Dār al-Fikr al-Mouaser.
- Alias Azhar. (2017). *Praktis Hibah di Malaysia*. Sintok: UUM Press.
- Amir Bahari. (2014). *Islamic Estate, Retirement and Waqf Planning*. Kuala Lumpur : IBFIM.
- Ansari, Zakariyya al-. (1418H). *Fath al-Wahhab bi Syarh Minhaj al-Tullab*. Beirut: Dar al-Kutub al-Ilmiyyah.
- Antonio, Muhammad Syafi'i. (2001). *Bank Syariah: dari Teori ke Praktik*. Gema Insani: Jakarta.
- Azman Ismail. (2013). *Islamic Inheritance Planning 101*. Kuala Lumpur : IBFIM
- David J. Banks (1976), "Islam and Inheritance in Malaya: Culture Conflict or Islamic Revolution?" dalam *American Ethnologist*, j. 3, No. 4
- Ibn Manzur, Jamal al-Din Muhammad b Mukram (2003). *Lisan al-Arab*, j.9. Kaheerah : Dar al-Hadith
- Ibn Nujaim, Zainuddin b Ibrahim b Muhammad. (n.d). *Al-Ashbah Wa al-Nazhair 'Ala Mazhab abi Hanifah*. Beirut: Dar al-Kutub al-Ilmiyyah
- Ibn Qudamah al-Maqdisi. (1997). *Al-Mughni fi Fiqh al-Imam Ahmad b Hanbal*. Riyadh: Dar 'Alam al-Kutub
- Ibn Rusyd, Muhammad b Ahmad. (1988). *Bidayat al-Mujtahid wa Nihayat al-Muqtasid*. Beirut: Dar al-Kutub al-Ilmiyyah
- Irsyid, Mahmud Abdul Karim Ahmad. (2007). *Al-Syamil fi Muamalat wa Amaliyat Al-Masharif Al-Islamiyyah*. Dar Al-Nafais: Jordan.
- Ismail, F. (2016). Islamic Pensions: Developing Takāful Retirement Products, from Meena Insurance Review: <http://www.menainuranceclub.com/Article.aspx?id=13821>
- Ismail, Muhammad Bakr. (1997). *Al-Fiqh Al-Wadhih min Al-Kitab Wa Al-Sunnah 'Ala Al-Mazahib Al-Arba'ah*. Kaheerah : Egypt.
- ISRA. (2012). *Islamic Financial system; Principle & Operations*. Kuala Lumpur : ISRA.

- Kamus Dewan Edisi Keempat.(2007). Kuala Lumpur: Dewan Bahasa dan Pustaka.
- Khair, K, Gupta, L. and Shanmugam, B. (2008) *Islamic Banking: A Practical Perspective*, Pearson Longman, Petaling Jaya.
- Md. Habibur Rahman1, Md. Faruk Abdullah1, Puspa Liza Ghazali1, and Noor Mohammad Osmani. (2019). *Application Of Umra And Ruqba Indisbursement Of Family Takaful Benefit: An Analysis From Shariah Perspective*. Asian Academy of Management Journal. Vol. 24, Supp. 1, 107–123.
- Mohammad Mahbubi Ali, Lokmanulhakim Hussain, Abdul Hakim Johari dan Faisal Haroon Zai.(2014). Struktur Patuh Syariah Untuk Pelan Takaful Anuiti Persaraan: Cadangan dan Cabaran, dalam *Muzakarah Cendekiawan Syariah Nusantara ke-8*. 28-29 Mei 2014.
- Mohd. Kamil Ahmad dan Joni Tamkin Borhan (2017). Penggunaan hibah bersyarat (bertaklik) dalam masalah pembahagian manfaat takaful: Analisis hukum. *Jurnal Syariah*, 25(1), 51 – 74
- Mohd Rofūzal Ibhram, Mohamed Yusef Niteh, Maad Ahmad, dan Mohd Kamarul Khaidzir Saadan (2017). *Al-nuqut dalam adat perkahwinan masyarakat Melayu*. Proceeding of 2nd International Conference on Law, Economics and Education (ICONLEE). 13th -14th December 2017, Grand Bluewave Hotel Shah Alam, Malaysia, 140-145.
- Muhammad, M, (2010) *Musharakah Ta''awuniyah for Takaful Operation*, ISRA bulletin, vol 06/Oct 10, p 10-11.
- Murphy, F. (2012, August 28). *The Rise of Sharia Compliant Retirement Planning*. Retrieved March 26, 2018, from Professional Advisor: <https://www.professionaladviser.com/retirement-planner/feature/22012-09/the-rise-of-sharia-compliant-retirement-planning>.
- Nasrul Hisyam Nor Muhamad.(2010).Pemakaian Prinsip Hibah Dalam Sistem KewanganIslam Di Malaysia: Tumpuan Kepada Industri Perbankan Islam Dan Takaful. *Jurnal Teknologi*, 52 Mei 2010: 69–81. Universiti Teknologi Malaysia (UTM).
- Nazrul Hazizi Noordin Muhammad Issyam Ismail Muhammad Abd Hadi Abd Rahman Siti Nurah Haron Adam Abdullah. (2016). Re-evaluating the practice of hibah trust in Malaysia in *Humanomics*. Vol. 32 Iss 4 pp. 418 – 436.
- Bank Negara Malaysia, *Shariah Resolutions in Islamic Finance*, 2007.
- Resolusi Syariah Dalam Kewangan Islam (2010).Bank Negara Malaysia.
- Tag El-Din, S. and Abdullah, N.I. (2007) Issues of implementing Islamic hire purchase in dual banking systems: Malaysia's experience. *Thunderbird InternationalBusiness Review*, 49 (2), 225-249.
- Wizarah al-Auqaf wa al-Syuun al-Islamiyyah. (1988). *Al-Mausu'ah Al-Fiqhiyyah al-Kuwaitiyyah*. Kuwait: Wizarah al-Auqaf wa al-Syuun al-Islamiyyah.
- Younes Soualhi.(2017). Challenges of developing a takaful retirement annuity plan in Malaysia. *ISRA International Journal of Islamic Finance* Vol. 9 No. 1, pp. 95-99.
- Internet sources
<https://www.agrobank.com.my/product/sahabat-agro/> 25 April 2020
<https://cdn.hsbcamanah.com.my/takaful-retirement-plan-regular.pdf> 25 April 2020

COMBATING ROAD ACCIDENT PRONENESS AMONG CAR DRIVERS IN MALAYSIA: PERSPECTIVES FROM MAQASID AL-SHARIAH

Muhammad Asyraf Mohd Kassim^a, Ahmad Bashir Aziz^b & Suhaila Abdul Hanan^c

^a*Faculty of Applied and Human Sciences, Universiti Malaysia Perlis, Malaysia*

^b*Islamic Business School, Universiti Utara Malaysia, Malaysia*

^c*School of Technology Management and Logistics, Universiti Utara Malaysia, Malaysia*

Abstract

The road accident phenomenon had raised concern among road users and the transport authorities. In this respect, road users have accountability to reduce road accident proneness among themselves. This duty is in line with the concept of protection of life (hifz al-nafs) under the maqasid al-Shariah. Researches have demonstrated that interrelated factors may place a driver at a high risk of road accidents such that road accidents may be caused by driver's behaviour with a combination of other factors such as environment and vehicle factors. Drivers' behaviours such as driving anger and aggressive driving have been the main contributors to road accidents. The objective of this paper is to examine the relationship between driving anger and aggressive driving towards road accident proneness from the maqasid al-Shariah perspective. The results of structural equation modelling reveal that driving anger and aggressive driving had a significant impact on road accident proneness. This study is significant as the discussion of the present research provides important theoretical and practical implications, and valuable suggestions to reduce road accident proneness for road users.

Keywords: Driving anger, aggressive driving, road accident proneness, road safety, road accident

1.0 INTRODUCTION

The scenario of road accidents nowadays has reached an alarming level that leads to fatalities and loss of lives. Malaysia has recorded staggering numbers of road accidents as the trend of road accidents is increasing by about 3% annually (Road Safety Department of Malaysia, 2019). Bukit Aman Traffic Investigation and Enforcement Department (2019) reported cars are the vehicles most involved in road accidents in Malaysia as well as car drivers and passengers are the most killed in road accidents. Road accidents had cause Malaysia a loss of billions (9.21 billion in the year 2018; (World Health Organization, 2019)). Road accidents caused a heavy burden to the victims and their families as they face a shortage of money in managing their household expenditure due to the intensive medical expenses or death of the wage earner in their family. This situation haunts dreadful imageries for every road user. Driver's behaviour had contributed about 85 per cent of road accidents worldwide (Bucsuházy et al., 2020; Chu et al., 2019). Among the primary contributing factors of driver's behaviour are driving anger and aggressive driving such as reckless driving, impatience as well as self-centeredness along with disobedience to the road and traffic regulations (Ismail et al., 2015, 2016).

2.0 LITERATURE REVIEW

Road accident proneness is still a new concept in road safety studies in Malaysia (Darma et al., 2017; Kamaluddin et al., 2019). Road accident proneness refers to drivers who have a higher tendency to involve in road accidents comparing with others when they are exposed to an equal hazard while driving on the road. Drivers are exposed to the same hazard when they are on the road, however, each of them has different perceptions and behaviour while driving that may influence drivers' affective demands, cognitive and emotional state while driving. Although, the concept of accident proneness leads the debates on developing preventive measures to combat road accidents globally (Mohamed & Bromfield, 2017; Sullman et al., 2019), little attention has been paid to the effect and significance of drivers' driving anger, aggressive driving and accident proneness. As the consequence, the scientific studies on accident proneness concept are very limited in the available literature including Malaysia (Darma et al., 2017; Kamaluddin et al., 2019). Therefore, in order to enhance sustainable countermeasures to reduce road accidents, it is therefore necessary to conceptualize and conduct research on accident proneness.

Anger is an emotional and physiological arousal that is provoked by perceived affronts, injustices, frustrations, and other sources of provocation (Spielberger et al., 1999). Deffenbacher et al., (2016) indicated that driving anger refers to an individual's emotional and physiological arousal to become angry when facing provocation and frustration situations on the road. Individuals with high anger are likely to express anger more frequently and intensely while driving; resulting in more traffic violations and road accidents, compared to low anger drivers (Qu et al., 2016). Besides that, drivers with a high level of anger are more likely to respond angrily to provoking situations, experiencing more intense driving style that could lead to road accidents (Zhang & Chan, 2016).

Qu et al. (2016) indicated that it is more interesting to investigate the driver's anger expression while driving in a same situation (e.g., a slow car in front of them) as both drivers express their anger in dramatically different manner. One driver might get very angry, honking, give the slow driver a sharp stare, overtake him and might get involved in a road accident. Meanwhile, the other driver chose to drive behind the car patiently, continue to drive safely and prevent himself from involving in a road accident (Qu et al., 2016). The driver's anger expression while driving play an important role in determining the driving outcome of the driver whether to be involved in a road accident or resulting in safe driving. Therefore, driver's expression of anger is very important to be studied as this study provides a clearer understanding on the relationship between driving anger and road accident proneness.

The driving behaviour and number of road accidents are primarily dictated by the style of the driver wants to drive or always drives. Aggressive driving continues to be the most common means that contributes to road accidents (Chu et al., 2019; Mehdizadeh et al., 2018). Definitions of aggressive driving has been argued based on observational behaviours and intentional behaviours (Zhang et al., 2017). Some studies that focused on observational behaviours have described aggressive driving as any reckless driving neglecting the safety of other road users by exposing them in unwanted danger (Bernstein & Calamia, 2019; Cheung et al., 2018). Other researchers that focused on the intentional behaviours described aggressive driving as any type of driving style that is intended to physically or psychologically damage or injure other road users (Alonso et al., 2019; Ball et al., 2018; Chraif et al., 2016). The present study will be using the second definition considering intention as the main factor and in line with the universal description of aggressive behaviour derived from the past studies. Thus, aggressive driving is defined as any unsafe driving actions that is carried out to cause harm intentionally to other road users. The constitution of aggressive driving with intention, for instance, drivers speed up to overtake and trying to annoy other drivers.

There are several studies were conducted to examine the relationship of driving anger and aggressive driving on road accident proneness in Malaysia. Equally important, drivers' driving anger towards road accident proneness is also essential to be investigated since they will ultimately be related to the person's safety on the road. For example, Sullman et al. (2015) conducted a study among car drivers to prove the evidence that driving anger contributes to high level of road accident proneness. The findings showed that driving anger relates strongly with road accident proneness including minor and major accidents. They also discovered that driving anger would foster driver's intension of hurting. Besides that, (Rohani & Buhari, 2013) presented further support for the influence of anger expressions in prediction of accident among bus drivers. Their studies have been done to examine the role of driving anger on road accident proneness among drivers with their age range from 35 to 49 years old. Results showed that bus drivers with age their age range from 36 to 49 years old had a combination of aggressive and adaptive anger expression while driving. Further, the analysis revealed this group of drivers have high level of road accident proneness. Based on the evidence given by Rohani and Buhari (2013), this study assumes that drivers who frequently express their anger while driving may have greater and continuing tendency to involve in road accidents.

Besides that, Ismail et al., (2016) conducted a study to investigate the relationship between aggressive driving and road accident proneness. They focused on the aggression in traffic, and presented that aggressive driving was significantly related with road accident proneness. In this study, Ismail et al. (2016) reported that the most dominant aggressive driving actions are excessive speeding, tailgating, failure to yield the right of way for other road users and red light running. This statement indicates that drivers who behave in such ways are also more likely to conduct other types of aggressive driving that increases the accidents proneness. A study was done by Khan et al. (2015) with the main objective of this study is to identify the effects of aggressive driving and road accident proneness. In addition, the study attempts to increase drivers' awareness of their actions in the traffic and point out the consequences associated with these actions. This study discovered that most of the drivers are involved in road accidents due to aggressive driving as least once in their life. Besides that, aggressive driving such as pushing a car off the roadway, deliberate obstruction of passing vehicles, pursuing a vehicle, excessive high speed, and tailgating are considered at the top of the list according to the study findings (Khan et al., 2015).

Although the previous studies by Ismail et al. (2016), Khan et al. (2015), Rohani and Buhari (2013) and Sullman et al. (2015) presented clearer evidence on the relationship between driving anger and aggressive driving on road accident proneness as well as preventive measures to combat road accident proneness. However, this study provides

a difference from previous studies (Ismail et al., 2016; Khan et al., 2015; Rohani & Buhari, 2013; Sullman et al., 2015) in combating road accidents by focusing on guidance based on maqasid-al-Shariah. The guidance of maqasid al-Shariah is important for human beings to derive solutions to contemporary problems faced by people. The maqasid al-Shariah provides a clear guidance and framework to the process of ijtihad in solving the issues conforming to the human interest while complying with the will of God. Therefore, this study will discuss several preventive measures based on maqasid al-Shariah to combat road accident proneness among Malaysian drivers.

3.0 FIQH ON ROAD ACCIDENT PRONENESS

The law of the road is built on the concept of al-maslahah al-mursalah because it brings benefits and prevents harm as well as because it is not mentioned by syara' whether it is taken into account or it is cancelled (not taken into account). However, al-Syathibi (2006) added several other conditions to enable practising with al-maslahah al-mursalah, namely, the maslahah should be in line with the maqasid al-Shariah, it must be acceptable to the mind and should adhere to the maslahah to take care of dharuri (important) matters or to lift difficulties. Therefore, the al-maslahah al-mursalah is very accurate and suitable to be applied to the rules of the road as it is in line with the maqasid al-Shariah. The enforcement on these preventive measures are intended to protect human life concerning hifz al-nafs (keeping life) is one of the main thrusts in the maqasid al-Shariah.

The laws of driving anger and aggressive driving based on maqasid al-Shariah are discussed as below:

- **Laws of driving dangerously**

Ismail et al. (2016) indicated that dangerous driving is action of aggressive driving that can lead to road accidents. Aggressive driving such as red-light running, dangerous overtaking, driving with excessive speed and tailgating are the most common driving actions practised by the Malaysian drivers (Bukit Aman Traffic Investigation and Enforcement Department, 2019). Therefore, it is necessary to study this behaviour according to Islamic law. The word of Allah SWT mentioned about this law in Surah Al-Baqarah (195):

المُحْسِنِينَ يُحِبُّ اللَّهُ إِنَّ وَأَخْسِنُوا التَّهْلُكَةَ إِلَى بَأْيَيْكُمْ تُلْفُوا وَلَا

Meaning: *And do not deliberately throw yourselves into the danger of destruction (by being stingy); and correct (your best efforts) and your deeds; for verily Allah loveth those who strive to improve their deeds.*

In the above verse clearly shows the prohibition to do something dangerous to ourselves. Indeed, Islam is a religion that strongly emphasizes the importance of self-care in line with maqasid al-Shariah with the obligation to take care of the human mind and self. Then the above verse also emphasizes the importance of being compassionate, compassionate or doing something carefully in all aspects of life. The command to perform this kindness is common to all things because the above verse does not come in a muqayyad form (bound or specific) (Abd al-Rahman ibn Nasir Sa'di, 1990).

Thus, dangerous driving is prohibited as it can lead to accidents whether involving others or not. Based on the principle of maqasid-al-Shariah, Islam strongly rejects any form of harm that may occur. Therefore, all drivers are advised to drive carefully and avoid dangerous driving. Indeed, nothing can change the statistics of accidents, except human beings themselves as stated by Allah SWT in Surah Ar-Ra'ad (11)

بأنفسهم ما يُعْزِرُوا حَتَّى يَقُومَ مَا يُعْزِرُ لَا اللَّهُ إِنَّ

Meaning: *Indeed, Allah does not change what is in a people until they change what is in themselves.*

- **Laws of cutting-in another vehicle**

Cutting-in another vehicle on the road is a common occurrence especially during traffic jams. Besides that, drivers also usually cut the queue to pay tolls and exiting or entering a junction. The drivers' impatience and selfishness are the main reasons why they like to cut other vehicles on the road. The act of cutting-in is one of the actions that violate the government's rules which we are required to obey as long as it is not contrary to the syara'. Allah SWT says in Surah Al-Baqarah verse 59:

مَنْكُمُ الْأَمْرَ وَأُولَى الرَّسُولَ وَأَطِيعُوا اللَّهَ أَطِيعُوا اللَّهَ آمَنُوا الَّذِينَ يَأْتِيهَا

Meaning: *O you who believe, obey Allah and obey the Messenger of Allah and the government (of those in power) from among you*

The Prophet (SAW) said:

المَعْرُوفِ فِي الطَّاعَةِ إِلَّا مَا، مَعْصِيَةٍ فِي طَّاعَةٍ لَا

Meaning: *There is no obedience in matters of immorality, indeed obedience is in matters of goodness*

The act of cutting-in another vehicle on the road can cause harm to the driver and other drivers as well as can also cause road accident resulting loss of life or damage to the vehicle. The act of cutting the line can also cause other drivers to become angry and resulting in fights and quarrels among them. This behaviour is forbidden in the syara' as the words of Allah SWT and the words of the Prophet SAW:

الصَّابِرِينَ عَمَّ اللَّهُ إِنَّ وَاصْبِرُوا رِيحَكُمْ وَتَذْهَبَ فَتَنْفُسُوا تَتَّزَعُوا وَلَا وَرَسُولَهُ اللَّهُ وَأَطِيعُوا

Meaning: *And obey Allah and His Messenger, and do not argue; otherwise you will become weak in spirit and lose your strength, and be patient (facing all difficulties with fortitude); Indeed, Allah SWT is with those who are patient*

(Surah Al-Anfal: 46)

تَذَابَرُوا وَلَا ، تَحَاسَدُوا وَلَا ، تَبَاغَضُوا لَا

Meaning: Do not all of you insult each other, envy-envy, sarcasm.

al-Bukhari (6065) dan Muslim (2559)

Thus, the law of cutting the line is prohibited and not allowed except for emergencies such as a person is required to arrive at the hospital as soon as possible or in a state of obtaining permission from all other drivers involved if want to cut them.

4.0 MAQASID AL-SHARIAH PREVENTIVE MEASURES

The scenario of road accidents nowadays has reached an alarming level that leads towards fatalities and loss of lives. This study suggests solutions based on maqasid al-Shariah to combat road accidents among Malaysian drivers. The teachings of Islam involve guidance and regulations that would lead towards the beautification of characters and personalities in all walks of life, inculcates the atmosphere of love, affirmation and cooperation (Hassan et al., 2013). Islamic ethics outlined clear ethics of road usage that need to be upheld by all mankind. This is because the public, in particular, road users have the rights to utilize the roads and highways. Islam is indeed against any actions leading towards any form of hazards for the road users. This study clarifies and outlines these ethics from the Islamic perspective.

Islam is a universal and complete religion that emphasizes the values of ethics and morality in human life which can be practised by all mankind globally (Yahiji et al., 2018). It is paramount in its teachings that it became one of the main reasons why the Prophet sent to the earth as stated in one famous hadith narrated by Abu Hurairah r.anhu that the Prophet said:

I have been sent for the perfection of character (to make perfect of man's characters and morals)

reported by Imam Ahmad and Baihaqi

As a comprehensive and complete way of life, Islam provides ethics and moral codes as one of the fundamental branches of life for every individual; in fact, following them is mandatory for everyone as ethical or moral codes in Islam form the basis for the establishment of a community (Yahiji et al., 2018). Ethics or morals in Islam strives to develop and nurture man's spiritual faculty while directing the conduct and attitude of individuals towards the good in addition to reminding the dangers and disadvantages of each crime for them to try to stay away from being influenced by negative forces (Hassan et al., 2013).

Considering the importance of practising the Islamic ethics in driving, this study suggests ethics of road usage from the Islamic perspective that should be upheld by everyone particularly those who regularly break traffic rules, so that they are not only aware that they had violated traffic rules in the world but it will be rewarded accordingly by

Allah for what they have done (Hassan et al., 2013). Islam perceives rewards and punishments in the hereafter encompassing every aspect of life including matters related to human behaviour on the road (Yahiji et al., 2018).

The Islamic ethics on the usage of the road that will be suggested in this study are based on evidence from the Quran and the Prophet (SAW)'s traditions. Among them are as follows:

- **Beginning every journey with a prayer**

First of all, a Muslim should recite prayers before starting their journey (Abdulkareem & Mamseni, 2019). This is because prayer is a demand for people to Allah to provide protection from all disasters while travelling. There are several Prophet (SAW)'s hadith that teach people about travelling prayers and while getting in a transport. Prayers can even be adapted to specific conditions during the journey or transport (Abdulkareem & Mamseni, 2019). Among them are those who intend to start the trip are encouraged to bid farewell to their family or relatives because by doing so, the prayer that they will be asked to give advantages to those who intend to make the trip.

In addition, while boarding a vehicle, Islam teaches for road users to read certain prayers. Among them are quoted in the prayer in the Holy Qur'an (Surah al-Zukhruf 43:13-14):

سُبْحَانَ الَّذِي سَخَّرْنَا هَذَا وَمَا كُنَّا لَهُ مُقْرِنِينَ. وَإِنَّا إِلَىٰ رَبِّنَا لَمُنْقَلِبُونَ

Means: *Glory to Him who has subjected the vehicle to us when we were not capable of handling it and we will get back to our Lord!*

The advantage of praying before travelling is to protect ourselves from confronting any misfortunes while travelling, provide peace and comfort to road users to be protected by Allah from all accidents and disasters that befall them on the trip (Abdulkareem & Mamseni, 2019).

- **Never be arrogant on roads**

In the Quran, God forbids people including road users from being arrogant and imperious as stated in Surah al-Isra verse 37:

طُولًا الْجِبَالِ تَبْلُغَ وَلَنَ الْأَرْضِ تَخْرُقَ لَنَ إِنَّكَ مَرَحًا الْأَرْضِ فِي تَمْشٍ وَلَا

Means: *Do not walk in a swank and arrogance in the face of the earth itself, surely you will not be able to dig the earth and will not be able to match the height of the mountains.*

Besides that, Allah says in Surah Furqan, verse 63:

سَلَامًا قَالُوا الْجَاهِلُونَ خَاطِبَهُمْ وَإِذَا هَوَّنَا الْأَرْضِ عَلَىٰ يَمْشُونَ الَّذِينَ الرَّحْمَنِ وَعِبَادُ

Means: *The servants of the All-beneficent (Allah) are those who walk humbly on the earth, and when the ignorant address them, say, 'Peace!'*

In the context of road user, someone who has ethical values should not take the opportunity to show their prowess with reckless driving, speeding and overtaking recklessly, cutting the line of vehicles, racing on the road, driving to attract public attention, the use of excessive vehicle horn, turning the loudspeaker installed in a vehicle loudly without shame, disturbing the other users' peace and so on (Hassan et al., 2013). Thus, for people who really have a high ethical value should not be cocky and arrogant on the road because it will bring danger to themselves and to others. Road users should be patient and tolerant because the road is a shared property and right.

- **To be unharmed to oneself and others**

Among the ethics for road users is not to do anything that may be harmful either to themselves or others. According to Abdulkareem and Mamseni (2019), the public has the right to use vehicles on the road with the condition that safety of road users must be paramount to avoid dangers.

Abdulkareem and Mamseni (2019) indicated that it is imperative for road users to always be careful when using it to avoid any harm to other users. The neglect of this duty will deprive the road user of the right to use the road. However, this kind of situation is subject to the ability of other road users or are in a state that can be controlled by

the user (Yahiji et al., 2018). This is consistent with the hadith of the Prophet (SAW) narrated by Abu Said Sad Bin Malik Bin Sinan Al-Khudri. anhu which means:

*No harm and no harm (to others)
reported by Ibn Majah and al-Daraqutni*

This means that every road user should follow traffic rules, such as having a driving license, owning vehicle in perfect condition, complying with speed limits and so forth. Even within Islam itself, there are a number of penalties imposed on those who commit offenses on the road whether that involves life, the body or property (Yahiji et al., 2018).

Some of the road users drive recklessly. They drive their vehicles with a display of dangerous actions in order to attract other road user's attention. They seem not to care about the consequences and effects that will occur due to the actions undertaken by them. This shows that they do not love their own lives when protecting and preserving life is the obligation of Islam and were among the five fundamental needs that should be fulfilled by men.

- **Prioritizing the necessities of other users**

A part of road ethics that Islam emphasizes is road users should pay attention to the needs of others while on the road, especially the urgent needs such as providing access to those in distress and so on (Hasan et al., 2013). This is a trait that gives priority to other road users and does not reflect the attitude of selfishness. For example, when we are stuck one on one with another car in a small path, we should give way to the other driver to move his vehicle. The nature of selfishness can be construed as putting self-interest alone without considering the needs of others. This is one of the vices that must be avoided by road users. The attitude of prioritizing the needs of others can create harmony and tolerance and ultimately may prevent further accidents and save lives road users are willing to give their way even if they have to compromise with their own situation on the road (Abdulkareem & Mamseni, 2019).

- **Good command of communication**

Yahiji et al. (2018) pointed out that using good commands of communication is also one of the ethical use of roads. Road users need to communicate well by removing the words that do not hurt the feeling of other road users. It is common to observe road users breaking road regulations. However, nasty words and insults must be avoided so as not to create things that did cause unwanted quarrels and enmity among the people. This situation is compatible with the hadith of Prophet (SAW) narrated by Abu Musa Al-Ash'ari. anhu which means:

*I asked the Messenger of Allah (SWT): "Who is the most excellent among the Muslims?" He said, "One who can give safety/secure from the point of his tongue (speech) and his hands."
reported by Bukhari and Muslim*

In conclusion, public interest on the road requires serious concern by all road users. The objective is very clear that is to maintain the safety of life and property as well as avoiding things that could interfere with one's comfort. Road users must consider that ethical use of the road is part of their life's faith and guidance. They must obey all traffic rules and any forms of non-compliance is considered guilty for violating the objectives of government's law itself and for the users who are driving carelessly and causing death and disabilities will be appropriately punished either in this world and the hereafter. Road users should always be aware of the fact that living together need for respect for the rights of others on the road.

5.0 CONCLUSION

In conclusion, this study highlighted the importance of Muslims to understand the road fiqh because by simply obeying the traffic rules without the support of a strong religious understanding will make human beings negligent in pursuing the limits of sin and reward. There are many texts in the Qur'an, hadith, the rules of fiqh and the views of the fuqaha that can be inferred and utilized in identifying the law of taklifi against behaviour or action on the road. It coincides with the concept of accountability that must be borne by every mukallaf Muslim for whatever his actions and actions. The government has full responsibility to determine the rules and forms of road enforcement to ensure the safety of road users and public property. This is in accordance with the maqasid al-Shariah which advocates the preservation of life and property. Finally, the discussion of the present research provides valuable suggestions according to maqasid al-Shariah to combat road accident proneness for road users.

ACKNOWLEDGEMENTS

The author would like to acknowledge the support from the Malaysia Ministry of Higher Education under a research grant of Fundamental Research Grant Scheme (FRGS) (Ref: FRGS/1/2019/SS05/UNIMAP/03/1) and supported by the Road Safety Department of Malaysia. However, the views expressed by the authors do not necessarily reflect those of either organization.

REFERENCES

- Abd al-Rahman ibn Nasir Sa`di. (1990). *Taysir al-Karim al-Rahman fi tafsir kalam al-mannan (1/145)*. al-Ri`asah al-`Ammah li-Idarah al-Buhuth al-`Ilmiyah wa-al-Iffa` wa-al-Dakwah wa-al-Irshad.
- Abdulkareem, S. J., & Mamseni, S. M. (2019). Road and road users their right's, duties, and ethics in Islamic Sharia. *Zanco Journal of Humanity Sciences*, 23(3), 229–244.
- al-Syathibi. (2006). *al-I'tisham (2/307-312)*. Pustaka Azzam.
- Alonso, F., Esteban, C., Montoro, L., & Serge, A. (2019). Conceptualization of aggressive driving behaviors through a Perception of aggressive driving scale (PAD). *Transportation Research Part F: Traffic Psychology and Behaviour*, 60, 415–426. <https://doi.org/10.1016/j.trf.2018.10.032>
- Ball, L., Tully, R., & Egan, V. (2018). The influence of impulsivity and the Dark Triad on self-reported aggressive driving behaviours. *Accident Analysis and Prevention*, 120(February), 130–138. <https://doi.org/10.1016/j.aap.2018.08.010>
- Bernstein, J. P. K., & Calamia, M. (2019). Dimensions of driving-related emotions and behaviors: An exploratory factor analysis of common self-report measures. *Accident Analysis and Prevention*, 124(November 2018), 85–91. <https://doi.org/10.1016/j.aap.2019.01.004>
- Bucsuházy, K., Matuchová, E., Zivala, R., Moravcová, P., Kostíková, M., & Mikulec, R. (2020). Human factors contributing to the road traffic accident occurrence. *Transportation Research Procedia*, 45(2019), 555–561. <https://doi.org/10.1016/j.trpro.2020.03.057>
- Bukit Aman Traffic Investigation and Enforcement Department. (2019). *Transport Statistic Malaysia*.
- Cheung, E., Bera, A., & Manocha, D. (2018). Efficient and safe vehicle navigation based on driver behavior classification. *IEEE Computer Society Conference on Computer Vision and Pattern Recognition Workshops, 2018-June*, 1137–1144. <https://doi.org/10.1109/CVPRW.2018.00149>
- Chraif, M., Aniței, M., Burtăverde, V., & Mihăilă, T. (2016). The link between personality, aggressive driving, and risky driving outcomes – testing a theoretical model. *Journal of Risk Research*, 19(6), 780–797. <https://doi.org/10.1080/13669877.2015.1042500>
- Chu, W., Wu, C., Atombo, C., Zhang, H., & Özkan, T. (2019). Traffic climate, driver behaviour, and accidents involvement in China. *Accident Analysis and Prevention*, 122(1178), 119–126. <https://doi.org/10.1016/j.aap.2018.09.007>
- Darma, Y., Karim, M. R., & Abdullah, S. (2017). An analysis of Malaysia road traffic death distribution by road environment. *Sadhana - Academy Proceedings in Engineering Sciences*, 42(9), 1605–1615. <https://doi.org/10.1007/s12046-017-0694-9>
- Defenbacher, J. L., Stephens, A. N., & Sullman, M. J. (2016). Driving anger as a psychological construct: Twenty years of research using the Driving Anger Scale. *Transportation Research Part F: Traffic Psychology and Behaviour*, 42, 236–247.
- Hassan, W. Z. W., Alias, J., Ahmad, B. A., Zainal, K., Muslim, N., Umar, A., & Kanan, H. (2013). Ethics of road usage from Islamic perspective. *The Social Sciences*, 8(2), 94–99.
- Ismail, R., Che Din, N., Ong, L. L., Ibrahim, N., & Sukimi, F. (2015). Role of sensation seeking and aggression on risk riding. *Journal of Social Science and Humanities*, 1(1), 169–178. <https://doi.org/ISSN:1833-884x>
- Ismail, R., Voon, N. L., & Ibrahim, N. (2016). Aberrant driving among young Malaysian drivers. *Jurnal Teknologi*, 78(6–10), 55–62.
- Kamaluddin, N. A., Abd Rahman, M. F., & Várhelyi, A. (2019). Matching of police and hospital road crash casualty records – a data-linkage study in Malaysia. *International Journal of Injury Control and Safety Promotion*, 26(1), 52–59. <https://doi.org/10.1080/17457300.2018.1476385>
- Khan, S. ur R., Khalifah, Z. B., Munir, Y., Islam, T., Nazir, T., & Khan, H. (2015). Driving behaviours, traffic risk and road safety: comparative study between Malaysia and Singapore. *International Journal of Injury Control and Safety Promotion*, 22(4), 359–367. <https://doi.org/10.1080/17457300.2014.925938>
- Mehdizadeh, M., Shariat-Mohaymany, A., & Nordfjaern, T. (2018). Accident involvement among Iranian lorry drivers: Direct and indirect effects of background variables and aberrant driving behaviour. *Transportation Research Part F: Traffic Psychology and Behaviour*, 58, 39–55. <https://doi.org/10.1016/j.trf.2018.05.029>
- Mohamed, M., & Bromfield, N. F. (2017). Attitudes, driving behavior, and accident involvement among young male drivers in Saudi Arabia. *Transportation Research Part F: Traffic Psychology and Behaviour*, 47, 59–71.
- Qu, W., Dai, M., Zhao, W., Zhang, K., & Ge, Y. (2016). Expressing anger is more dangerous than feeling angry when driving. *PLoS ONE*, 11(6), 1–11. <https://doi.org/10.1371/journal.pone.0156948>
- Road Safety Department of Malaysia. (2019). *Road Accidents Statistics*. Ministry of Transportation Malaysia.
- Rohani, M. M., & Buhari, R. (2013). Table 1: Review of bus driver behavior studies from previous researcher. *9th International Conference of Geotechnical and Transportation Engineering (GEOTROPIKA) and 1st International Conference on Construction and Building Engineering (ICONBUILD) - GEOCON2013*.
- Spielberger, C. D., Sydeman, S. J., Owen, A. E., & Marsh, B. J. (1999). *Measuring anxiety and anger with the State-Trait Anxiety Inventory (STAI) and the State-Trait Anger Expression Inventory (STAXI)*. Lawrence Erlbaum Associates Publishers.
- Sullman, M. J. M., Stephens, A. N., & Taylor, J. E. (2019). Dimensions of aberrant driving behaviour and their relation to crash involvement for

- drivers in New Zealand. *Transportation Research Part F: Traffic Psychology and Behaviour*, 66, 111–121. <https://doi.org/10.1016/j.trf.2019.08.024>
- Sullman, M. J. M., Stephens, A. N., & Yong, M. (2015). Anger, aggression and road rage behaviour in Malaysian drivers. *Transportation Research Part F: Traffic Psychology and Behaviour*, 29, 70–82. <https://doi.org/10.1016/j.trf.2015.01.006>
- World Health Organization. (2019). *Global Status Report On Road Safety 2019*.
- Yahiji, K., Sukmawati, H., Alfin, J., & Mahfid, C. (2018). Traffic education in contemporary Islamic education curriculum in Indonesia. *Tadarus: Jurnal Pendidikan Islam*, 7(2), 56–69.
- Zhang, H., Qu, W., Ge, Y., Sun, X., & Zhang, K. (2017). Effect of personality traits, age and sex on aggressive driving: Psychometric adaptation of the Driver Aggression Indicators Scale in China. *Accident Analysis & Prevention*, 103, 29–36.
- Zhang, T., & Chan, A. H. (2016). The association between driving anger and driving outcomes: A meta-analysis of evidence from the past twenty years. *Accident Analysis and Prevention*, 90, 50–62.

MAQASID SHARIAH APPLICATIONS AS A PARAMETER FOR MUSLIM TOURISM PACKAGE IN MALAYSIA

Noor Syahirah Zakaria^a, Azizah Othman^b & Nor Ashikin Mohd Nor^c

^{ab}Islamic Business School, Universiti Utara Malaysia, Malaysia

^cCollege of Arts and Science, Universiti Utara Malaysia

Abstract

Traveling is part of the routine of human life that always wants to experience relaxation, excitement and happiness. In the Quran there is some surah that promotes travel activity such as al-Mulk, Muhammad, Luqman, Yusuf, Ar-Rum, Ali Imran, Ar-Rum, An-Naml and Al-An 'Aam. In this regard, Islam has outlined guidelines to ensure that tourism activities are in line with Islamic requirements and thus adhere to the meaning of worship in these activities. This paper will discuss the five core elements that are the essence of *maqasid syariah* in tourism activities from an Islamic perspective. The application of the concept of *maqasid syariah* is a parameter in measuring industry understanding in the hospitality and tourism sectors that are the focus of this study. In this context the activity should follow the five basic things called the *daruriyyat al-khams*, the preservation of religion, life, intellect, dignity and wealth. This method of writing is based on references and research on documents from various sources such as articles, journals, books, brochures and empirical studies.

Keywords: Maqasid Shariah, Islamic Tourism, Islamic Tour Package, Shariah Compliance

1.0 INTRODUCTION

In Islam, travelling and exploring in tourism may be considered as *Ibadah* if the purpose is for Allah blessing and avoid the wrongdoings (Othman, Mohd Taha & Othman, 2015; Kamarudin & Ismail, 2012). Islam is a religion that often encourages people to travel to every corner of the world and not only look at the local area but also tourism can bring people closer to its creator by seeing the beauty of nature and contemplating the awards created by the Almighty (Mohd Noor & Mohd Noor, 2018). In addition, Islam also encourages mankind to travel so that they appreciate of the God's creation as suggested by Allah S.W.T in the Qur'anic verse surah al-Ankabut verse 20 which is:

"Travel through the land and observe how He began creation. Then Allah will produce the final creation. Indeed Allah, over all things, is competent".

The concept of Islamic tourism has a significant difference compared to commercial tourism because commercial tourism prioritizes profit and customer satisfaction compared to Islamic tourism which places the pleasure of Allah S.W.T as the main goal (Graburn, 1977). However, words such as 'pleasure' and 'entertainment' need to be interpreted carefully because Muslims are allowed to seek pleasure and entertainment only in ways that do not go beyond the rules and obligations of Islamic law (Saad, Kassem & Scott, 2010).

2.0 LITERATURE REVIEW

This section discusses the concept of *maqasid syariah*. Another section discusses the '*dharuriyyat al-khams*' namely preservation of religion, preservation of life, preservation of intellect, preservation of progeny and preservation of wealth according to muslim tourism package in Malaysia.

2.1 MAQASID SHARIAH

The concept *maqasid syariah* is broad, and researchers have only focused on the '*Dharuriyyat Al-Khams*' namely *Hifz al-Din* (preservation of religion), *Hifz al-Nafs* (preservation of life), *Hifz al-Aql* (preservation of intellect), *Hifz al-Nasab* (preservation of progeny) and *Hifz-al-Mal* (preservation of wealth). The objectives of the *Shari'ah* are described in the Quran:

“O mankind, a direction has come to you from your Lord; it is a healing for the spiritual ailments in your heart and it is guidance and mercy for the believers”
(Surah Yunus: 57;10)

From a linguistic point of view, *maqasid* is a plural word from *maqad* and *maqsid* (المقصد) which comes from the word *qasada* (قصد) which means to go in one direction. While *Shariah* comes from the word *syaraa* (شرع) which means the source of water which is the source of drink, the path, what is prescribed by Allah from the aspect of faith and law, religion and the view of the *mazhab* that is clear and straight. In terms of terminology, it covers the whole of what Allah S.W.T revealed to mankind through the Prophet S.A.W. As for the term *syara*, the ulama' have presented various definitions of *maqasid shariah* (Mufti of Federal Territory, 2019) Sheikh Dr. Ahmad al-Raisuni Hafizahullah view that the *maqasid shariah* is:

“The purposes set by the Shari’ah to realize human benefits” (Refer to *Nazhariyyatul Maqasid* ‘inda al-Imam al-Syathibi, p. 7). (Mufti of Federal Territory, 2019).

2.1.1 Preservation of Religion (Hifz al-Din)

Preservation of religion (Hifz ad-Din) means avoiding anything that might violate and destroy the foundations of religion (Amir Nur Rashid, 2019). To be in harmonious with the preservation of religion, religious facilities or tangible or intangible attributes should be increased in the Islamic tourism characteristic such as worship facilities like prayer rooms, separate tourism recreational facilities for men and women, halal foods services and others (Fisol, Suid, Saufi & Bahari, 2019). As a tour operator in a tour package who provides the package, it is a duty to put their interests first in religion in the top places. To ensure this preservation of religion for example, the hotel operator must understand that his company is a form of worship to Allah, other than it is a mandatory demand of *kifayah* to Muslims (Mohd Noor & Mohd Noor, 2018). In addition, in the context of Islamic tourism, preservation of religion can be seen through the provision of places of worship which is suitable in hotel rooms (Abd Wahab, Ab Hamid, Che Man & Hashim, 2019). Allah S.W.T said:

“Allah has explained to you - among the matters of religion that He has ordained - as that which He has enjoined on Nuh, and that which We (Allah) have revealed to you (O Muhammad), and that which We have enjoined on Ibrahim, Musa, and Isa. Namely, that ye should remain steadfast in Religion, and make no divisions therein; it is hard for the polytheists (to accept monotheism) to which you call them. Allah chooses to bring to His Religion of Monotheism whom He pleases, and guides to His Religion those who turn to Him (in obedience)”.
(Al-Syuura: 42;13)

Generally, shariah compliant tourism products refer to all such products conforming with the instructions of Allah S.W.T and Prophet Muhammad S.A.W (Stephenson, 2014; Zamani-Farahani & Henderson, 2010)

2.1.2 Preservation of Life (Hifz al-Nafs)

Preservation of life (Hifz al-Nafs) should be taken into account for Muslim tourists when travelling, which emphasizes the safety for the Muslim tourists and for every traveller that offers a safe trip including transportation and accommodation which is not including travelling to any potentially dangerous destinations and activities such as travelling to the war countries without any safety provided by those countries. It is important in Islamic tourism by providing *takaful* protection for the tourist as a value added for the preservation of life (Mohamed Fisol et al., 2019). Security factors also affect the arrival of foreign tourists to Malaysia. Rational travelers will usually only choose safe tourist destinations and peace. Not a single tourist is willing to take the risks that may bring death and loss to oneself. For example, the bombing incident of one of the hotels on the Island Bali, Indonesia in 2002 which claimed hundreds of lives of foreign tourists. The tourism sector in Bali experienced a drastic decline during the period. In addition, tour guides or agencies involved in the field of tourism are not allowed to take tourists to the places that could endanger the lives of tourists (Ahmad, 2015). This is proving that the safety factor is very important and as a catalyst for expanding the tourism sector in a country (Mapjabil, Abd Razak, Marzuki & Mohd Zainol, 2015).

Allah S.W.T said:

“And spend of your substance in the cause of Allah, and make not your own hands contribute to (your) destruction; but do good; for Allah loved those who do goodness”.
(Al-Baqarah: 195;2)

Hifz al-Nafs is also very important in terms of hygiene that affects the life span of human life. Prophet Muhammad (pbuh) said: “Cleanliness is half of faith” (Sahih Muslim). Hotel room, toilet, lobby, and all the hotel area must

always be in a clean and tidy condition, hotel cooking area or kitchen must be accredited or grade A from Department of Health (Mohd Noor & Mohd Noor, 2019). Not only from the aspect of halal food should be emphasized but also the aspect of hygiene should be given priority, premises operators need to ensure cleanliness in the accommodation, the environment, recreation areas and toilets are also clean (Mansor & Mohamad Rasit, 2015). Allah S.W.T said:

“Indeed, Allah loves those who are constantly repentant and loves those who purify themselves”
(Al-Baqarah: 222;2)

Islam is a way of life that encompasses human movements from waking up to bed. If prayer requires every Muslim to care about cleanliness, so does the demand of Islam so that cleanliness is maintained at all times in life. The cleanliness demanded by Islam not only involves oneself, but also the environment surrounded by various creatures of Allah. Allah S. W. T said:

“O you who have believed, when you rise to [perform] prayer, wash your faces and your forearms to the elbows and wipe over your heads and wash your feet to the ankles. And if you are in a state of janabah, then purify yourselves. But if you are ill or on a journey or one of you comes from the place of relieving himself or you have contacted women and do not find water, then seek clean earth and wipe over your faces and hands with it. Allah does not intend to make difficulty for you, but He intends to purify you and complete His favor upon you that you may be grateful”.
(Al-Maidah: 6;5)

2.1.3 Preservation of Intellect (Hifz al-Aql)

Preserving the intellect (Hifz Al-Aql) in the maqasid shariah which means nourishing the intellect by acquiring knowledge and protecting it from anything that is harmful (Amir Nur Rashid et al., 2019). Indeed, the Shari'ah is not merely a theory, it is a practical and it is a way of life which is performed under the command of Allah S.W.T and obedience to Him. A Muslim is called upon to implement the concept of Hifz-al-Aql or to maintain common sense in everyday life. Therefore, every tourist activity should enable a tourist in order to ensure that the concept of Hifz al-'Aql is implemented (Abd Wahab et al., 2019). In the Quran there is a surah that promotes travel activity, and at the same time preserves the 'aql. Word of Allah S.W.T which means:

Say, WO Muhammad), “Travel through the land and observe how was the end of the criminals.”
(al-Naml: 69;27)

Based on these surah, Islam has always encouraged its people to travel to observe and enjoy the beauty of nature and also to think about the power of Allah S.W.T and to make efforts to meet the needs of life and fulfill their responsibilities as caliphs on this earth.

Protection of the mind requires safeguarding it from anything that might harm the ability and functions of the brain. This includes the consumption of liquor or similar substances that will upset the functions of the brain. The Qur'an forbids liquor when it says:

O you who believe! Intoxicants (in all forms), gambling, al-Ansab, and al-Azlam (arrows for seeking luck or decision) are an abomination of Shay tan's (Satan) handiwork. So avoid (strictly all) that (abomination) in order that you may be successful.
(al-Ma'idah: 90).

2.1.4 Preservation of Progeny (Hifz al-Nasab)

Prohibition of adultery as stated in the Qur'an and any act that may lead in that direction is also intended to preserve the dignity of each individual (Abd Wahab et al., 2019).

“And do not approach unlawful sexual intercourse. Indeed, it is ever an immorality and is evil as a way”.
(Al-Isra: 32;17)

The hotel should also be the aurat cover zone, where every visitor should cover their aurat perfectly and always dress modestly. Bathing areas such as swimming pools are separated between men and women or, the hotel introduced a 'private pool' package to facilitate women, especially bathing with full privacy and calm without interference from any man (Mohd Noor & Mohd Noor, 2018). In addition, shariah also forbids Muslim from adultery, which is Haram to visit places that involved with sexual permissiveness and it is not allowed to take place in the public based on Muslim scholars view (Battour, Ismail & Battor, 2011). In addition, as *shariah* definitely prohibit marketing destination by using promotion techniques of sexual appeal (Alserhan, 2010). Moreover,

2.1.5 Preservation of Wealth (Hifz al-Mal)

Islam outlines rules in property rights (Amir Nur Rashid, 2019). The concept of preservation of wealth (hifz al-mal) is a necessity for the livelihood with permissible (halal) services and received the blessings of Allah S.W.T (Fisol et al., 2019). Property is something that human beings desire directly in nature and necessity for human to conduct life in this world. Preservation of property (Hifz Al-Mal) according to syarak is divided into two aspects, namely exist 'wujud' and non-exist 'a'dam (Amir Nur Rashid et al., 2019). From the aspect of exist 'wujud'. It means doing something that can make, increase, or expand to earn a living, investing wealth in the way of God (Amir Nur Rashid et al., 2019). Allah S.W.T said in the Quran:

"It is He who made the earth tame for you - so walk among its slopes and eat of His provision - and to Him is the resurrection".
(Al-Mulk: 67;15)

Based on this text of the Al-Quran, we can see that Islam encourages its people to strive and seek sustenance in the world and earnestly by practicing good values such as honesty, trust, helpfulness fellow human beings and so on. The practice of Islam as a whole is able to form a safe society and harmony.

From the aspect of non-exist 'a'dam'. The meaning is to preserve something from loss or damage after the existence of such property banning gambling, usury, stealing and consuming other people's property (Amir Nur Rashid et al., 2019; Abd Wahab et al., 2019). The Qur'an emphasises this point when it says:

And eat up not one another's property unjustly (in any illegal way e.g. stealing, robbing, deceiving, etc.), nor give bribery to the rulers (judges before presenting your cases) that you may knowingly eat up a part of the property of others sinfully.
(Al-Baqarah: 188;2)

The Islamic approach emphasizes justice by prohibiting all forms of oppression, usury, fraud, corruption, monopoly, piracy, fraudulent intellectual property, market manipulation and any other form of mischief or damage or harm to others (Jabatan Kemajuan Islam Malaysia, 2015). All these forms are prohibiting in *Shari'ah*.

3.0 RESEARCH METHOD

Document analysis or qualitative document analysis is a form of qualitative research that is interpreted by researchers to give voice and meaning around the topic of an assessment (Bowen, 2009). In this study, researcher used a qualitative approach as a guide in obtaining the results of the study. A qualitative document analysis approach is used in this paper. This method of writing is based on references and research on documents from various sources such as articles, journals, books, brochures and empirical studies.

4.0 CONCLUSION

Tourism is an important industry that can help and develop the country's economy. Islam also provides important guidelines for ensuring that tourism activities meet the requirements of *Shari'a* by giving priority to the care of religion, intellect, dignity, posterity and property. It is responsibility for every Muslim that involved in tourism industry to carry out such religious mission in order to bring a positive impact on individuals, communities, ummah and the country. In conclusion, Shariah-compliant is now a requirement for travel agencies to conduct their business to promote Shariah-compliant tourism services (Hussin & Ahmad, 2018).

ACKNOWLEDGEMENTS

This paper is presented under 3rd UUM International Islamic Business Management Conference 2020. I would like to express my sincere gratitude to my supervisor for providing their invaluable guidance, comments and suggestions throughout this paper.

REFERENCES

- Ab Wahab, N.A., Ab Hamid, N., Che Man, N., & Hashim, S.N.I. (2019). Konsep Hifz Al-'Aql Dalam Aktiviti Pelancongan: Satu Kajian Awal, *Journal Of Muwafaqat*, Vol. 2, No.2, Pp. 73-92.
- Ahmad, N.A. (2015). *Hospitaliti dalam Pelancongan Islam*. Kuala Lumpur, Malaysia: Oxford Fajar.
- Alserhan, B.A. (2010). On Islamic Branding: Brands as Good Deeds. *Journal of Islamic Marketing*, 1(2), 101-106.
- Amir Nur Rashid, Z., Mazri, N.M., Md Sawari, M.F., & Megat Laksamana, N.H. (2019). Aplikasi Maqasid Syariah Dalam Sistem Pendidikan Di Malaysia: Pembelajaran Abad Ke-21, *International Journal of Business, Economics and Law*, Vol. 18, Issue 6.
- Bowen, G. A. (2009). Document analysis as a qualitative research method. *Qualitative Research Journal*, 9(2), 27-40. doi:10.3316/QRJ0902027.
- Battour, M., Ismail, M.N., & Battor, M. (2011). The Impact of Destination Attributes on Muslim Tourist's Choice. *International Journal of Tourism Research*, 13, 527-540.
- Graburn, N.H. (1977). *Tourism: The Sacred Journey*. The Anthropology of Tourism. University of Pennsylvania, Philadelphia. 17-31.
- Hussin, A.H., & Ahmad, S. (2018). Ke Arah Perlaksanaan Pelancongan Patuh Syariah Di Malaysia, at-Tahkim, Vo..8, No. 30, 30-35.
- Kamarudin, L.M., & Ismail, H.N. (2012). Membudayakan Pelancongan Islam di Malaysia: Strategi dan Isu. *The 9th Regional Symposium of the Malay Archipelago*. Universiti Teknologi MARA (Perak), Malaysia.
- Mansor, S.F., & Mohamad Rasit, R. (2015). Ciri-Ciri Hotel Patuh Syariah Terhadap Masa Depan Pelancongan Islam Di Malaysia: Satu Tinjauan Literatur, *Prosiding Kolokium Jejak Warisan Ilmu Islam (JEWARIS)*, Universiti Kebangsaan Malaysia.
- Mapjabil, J., Abd Razak, R.R., Marzuki, M., & Mohd Zainol, R. (2015). Pelancongan Islam: Suatu Tinjauan dan Relevannya di Malaysia, *Malaysia Journal of Society and Space*, 11(1), 172-182.
- Mohd Noor, M.I., & Mohd Noor, F.N. (2018). Pengaplikasian Maqasid Syariah Sebagai Parameter Konsep Hotel Patuh Syariah, *Jurnal 'Ulwan*, 99-109.
- Othman, N., Mohd Taha, R., & Othman, S. (2015). Maqasid Shariah in the Governance and Management Strategy of Islamic Tourism Business.
- Saad, S.H.A., Kassem, M., & Scott, N. (2010), *Tourism and Islamic Law*, in Noel Scott, Jafar Jafari (ed.) *Tourism in the Muslim World (Bridging Tourism Theory and Practice*, 2, 17-30.
- Stephenson, M. L. (2014). Deciphering "Islamic hospitality": Developments, Challenges and Opportunities. *Tourism Management*, 40, 155-164. doi:10.1016/j.tourman.2013.05.002.
- Zamani-farahani, H., & Henderson, J. C. (2010). Islamic Tourism and Managing Tourism. *International Journal of Tourism Research*, 89, 79-89. doi:10.1002/jtr.

THE IMPACT OF ISLAMIC BANKING AND FINTECH ON ECONOMIC GROWTH: AN EMPIRICAL ANALYSIS

Muhamad Fhadli Syakirin Mohd Jamalludin^a & Zairy Zainol^b

^a*Othman Yeop Abdullah Graduate School of Business (OYAGSB), Universiti Utara Malaysia*
^b*Islamic Business School, Universiti Utara Malaysia*

Abstract

The economic growth enhances standard of living of the people within the country. Precisely, based on Schumpeter's supply-leading theory, Islamic banking as a financial institution will contribute positively on the economic growth. However, due to Islamic banking market which is smaller as compared to conventional bank, the impact of Islamic banks is still ambiguous. The purpose of this research is to examine whether selected Islamic banks in nine countries which are Saudi Arabia, Malaysia, United Arab Emirates (UAE), Kuwait, Qatar, Turkey, Indonesia, Bahrain and Pakistan that have largest Global Shares in Islamic Finance Banking Assets support Schumpeter's supply-leading theory or otherwise. This paper also wants to examine the new variable that known as Fintech on economic growth as well to development of bank itself. The result showed Islamic banking has a positive impact on the economic growth. Furthermore, it's also found that Islamic banking and Fintech have a positive relationship between each other. This research contributes to the available literature in the Islamic banking industry as well as the economic growth. It suggests that regulators should support Islamic banking within their country by adjusting their policy to welcome the growth of Islamic banking itself. Other than that, regulators should also create a supportive space for new Fintech in order to sustain the growth of Islamic banking.

Keyword: Economic growth, Islamic banks, Schumpeter's supply-leading theory and Fintech.

1.0 INTRODUCTION

According to Brue and Grant (2013) economic growth can be driven by natural resources, human resources, capital and technological advancement. Whereby, economic development is the process of nation enhances its standard of living over time. The prior studied by Mckinnon and Shaw in 1973 (as cited in Boukhatem and Moussa, 2017) found capital accumulation and investment in banking sector can stimulate economy of a country. Nowadays, Islamic banking as a part of banking system is not just established to fulfil the obligation of Muslims to avoid *riba*, but the existence of Islamic banks also support economic growth with some evidence by contemporary researcher (Zirek, Celebi and Hassan, 2016; Boukhatem and Moussa, 2017). As mentioned in Schumpeter's supply-leading theory, financial institution will contribute positively on the economic growth. However, due to small portion of Islamic banks market compared with conventional banks, the impact of Islamic banks is still ambiguous.

Furthermore, Fintech penetration into Islamic finance is still in early stage that can contribute positively to the evolution of Islamic finance and at the same time it also has potential disruptions to traditional Islamic finance that cannot be underestimated. The positive impact of Fintech can also be seen in reducing bank's transactional risk whereby it can enhance the development of bank itself (Todorof, 2018). However, according to Baird (2016), researcher predict that Fintech could bring reduction to banks revenue between 10% and 40%. In year 2020, it is estimated that 15% and 25% of U.S banks could be shrinking as the result from Fintech and bank's regulations. In addition, the increasing of non-financial institution due to growing of Fintech that provide payment services (mobile payments and virtual currencies), alternative financing opportunity (P2P lending) and wealth management could shrinking the development of banking industry (Ramanova and Kundiska, 2017). Due to that problem, the question arises which is whether the Fintech also effect Islamic banks in the same way. Hence, this study aims to examine the impact development of Islamic banking on growth of Growth Domestic Product (GDP) by using panel data that only focusing on top nine largest Islamic finance banking assets which are Saudi Arabia, Malaysia, United Arab Emirates (UAE), Kuwait, Qatar, Turkey, Indonesia, Bahrain and Pakistan in year 2008 until 2017. In addition, this study will also examine new variable which is Fintech and how it affects the development of Islamic banking.

2.0 LITERATURE REVIEW

2.1 Relationship between Islamic Banking and Economic Growth

Zirek, Celebi and Hassan (2016) study on the Islamic banking variables on economic growth 14 member of Organization of Islamic country (OIC) in year 1999-2011. Their study found that, there is positive and significant relationship between Islamic banking and economic growth of OIC by employing the panel VAR method. The variable that represent Islamic banking are divided into three which is Islamic deposits, assets, and loans of Islamic banking. In the long run, the result shows economic growth responds positively to shocks in Islamic instruments, namely Islamic deposits, investments, and size. Zirek, Celebi and Hassan (2016) added that the instruments of Islamic banking shown to be an effective financial intermediaries whereby it's facilitated the transmission of funds from the surplus unit to deficit unit.

In other study; Imam and Kpodar (2016), their study is to analyse the relationship between Islamic banking development and economic growth for low and middle income countries by using the data in year 1990 to 2010. Their control variable studying effect Islamic banking development to economic growth is initial real GDP per capita, inflation, government consumption, education, trade openness, terms of trade and quality of institutions. Their finding shows that Islamic banking is positively associated with economic growth even after controlling for various determinants, including the level of financial depth.

Boukhatem and Moussa (2017) is seeking to develop a consistent theoretical framework for the relationship between Islamic finance and economic growth. On the other hand they also empirically study the effect of Islamic banking loans on the economic growth of MENA region during the 2000 until 2014 period. They found that economic growth can be accelerated by development of Islamic finance. The control variable in their study is inflation, education, government consumption expenditure, trade openness, rule of law and regulatory quality. Based on their result, they suggest that government need to consider implementing favourable economic and institutional policies that can make Islamic finance moves ahead.

Zarrouk, Ghak and Haija (2017), examine the causality between financial developments (general) including Islamic financial development (specific) on real economic growth started from year 1990 until 2012 in United Arab Emirates (UAE). Their finding shows that there is direction of causality runs from financial development on economic growth without having reverse causality (Zarrouk, Ghak and Haija, 2017). In the case of Islamic financial development, it does not cause economic growth but real gross domestic product (GDP) does causes Islamic financial development (Zarrouk, Ghak and Haija, 2017). In addition, forecasting results indicate that in order to have better progress in real economic activities there is need to concentrate on financial development (Zarrouk, Ghak and Haija, 2017). Their suggestion, there should be more effort promoting Islamic finance in order to make Dubai that located at UAE as the capital of Islamic economy.

Tabash and Dhankar (2014) study is analyse on relationship between Islamic finance system and economic growth in United Arab Emirates during 1990 until 2010. They used Islamic banks' financing credited to private sector through modes of financing as a proxy for the development of Islamic finance system. Their dependent variable is economic growth that proxied by gross domestic product (GDP) and Gross Fixed Capital Formation (GFCF). The result indicate that Islamic bank financing have strong positive association with economic growth in UAE. However, their result shows that the causal relationship only happens in one direction, i.e., from Islamic banks' financing to economic growth, which supports Schumpeter's supply-leading theory. Furthermore, their result shows that Islamic banks' financing also contribute to an increase of investment in UAE in the long term.

In case of Malaysia, there are two different finding found due to the impact of Islamic banks financing on the economic growth. Firstly, Hachicha and Amar (2015) study is analysing the impact of Islamic Bank Financing on Malaysia's on economic growth during 2000 (quarter one) until 2011 (quarter four). They used unit root tests to show that all variable are integrated of order 1. Their finding shows that in the long run, the GDP in Malaysia is not sensitive to the Islamic financing. The suggestion from Hachicha and Amar (2015) is strengthen the weight of the PLS-based instruments in the loan portfolios of the Malaysian Islamic banks in order to reduce inequalities and improve economic opportunities for people who have a high potential to contribute to the capital accumulation and the creation of the value-added.

However, studied by Kassim (2016) shows that Islamic bank financing for short run and long run both contribute positively and significantly on economic growth. In short run, there is Granger causality from Islamic banks financing on real economic activity. In long run, one percent change in Islamic financing will lead to 0.152 percent increase in industrial production. On the other hand, it is also found that Islamic banks deposit have a weak

relationship with economic growth in short run while in long run, it has equilibrium relationships on real economic growth. Due to that, Kassim (2016) suggest that the banks have to create longer term instrument of deposit like the counterpart of negotiable certificate in conventional banking.

2.2 Fintech and Economic Growth

Financial technology or known as Fintech will eventually contribute on the economic development through the efficiency of finance itself (Nakaso, 2016). According to him, “financial inclusion” that stimulated through Fintech clearly show the positive impact between finance and economy. He added by having access to Fintech, people in developing country that has limited access to payment services can also gain opportunity to expand their business such as e-commerce and e-learning. Due to that, Fintech is expected to have positive impact on economic growth (Nakaso, 2016).

2.3 Fintech and Bank Development

In perspective of banking development, financial technology (Fintech) can be significant determinant to banking industry’s revolution (Wonglimpiyarat, 2017; Gulamhuseinwala, Bull, Lewis, 2015). Nowadays, Fintech itself has attract firms especially bank in worldwide to growth along with the technology (Wonglimpiyarat, 2017). In addition, according studied done by Gupta and Xia (2018) found that the technology revolution (Fintech) in Asia such deposits and lending, capital raising, investment management, market provisioning, payments, and insurance allowed the bank itself to reduce risk, so that they can offer better services and also improve returns for the shareholders. Todorof (2018) added, Fintech also can be utilised to help reduce transactional risks that can benefit banks.

The positive impact of Fintech on development of bank does not only happen to conventional bank but also to Islamic banking (Todorof, 2018). He added Fintech also can provide greater transparency to stakeholder such as bankers, Islamic courts and customers in order to inspect the transaction that take place in *shariah* banking environments. However, according Ramanova and Kudinska (2017), even though Fintech is found as integral part of banking but nowadays there is increasing involvement of nonfinancial institutions such as in payment services (mobile payments and virtual currencies), start-up service provides, alternative financing opportunity (peer-to-peer lending and crowd funding) and wealth management. Due to this, business landscape in banking asking for more innovative solution (Ramanova and Kudinska, 2017). Hence, members of the financial services industry seeing the growing of Fintech could be a threat on development of banking industry (Ramanova and Kudinska, 2017). Furthermore, Anagnostopoulos (2018), realizes that many bank admitted the growth of Fintech companies threatened development of bank. Due to uncertainty, this study wants to explore the truth either the Fintech grows along with development of bank or otherwise.

In perspective of policies and regulation, most government around the world have paid attention on significant growing of Fintech by devised their policies and regulations in order to support Fintech development itself (Wonglimpiyarat, 2017). According to Fichman, 2014 (as cited in Anagnostopoulos, 2018), banking historically is the most resistant and suspicious to disruption by technology. However, banks currently facing the lack of innovation due to their stable market position before and the complex government regulation (Anagnostopoulos, 2018).

In terms of Fintech itself, according to Haddad and Hornuf (2018), Fintech market segment is positively impacted by the number of secure internet server, mobile telephone subscriptions and the available labor force. Shamim (2006), emphasizes that as the internet become broader, e-finance which is financial technology grows accordingly. According to MCMC Malaysia (2017), the estimated internet users in Malaysia is keep increasing which is 20.1 million, 24.1 million and 24.5 million in year 2014, 2015 and 2016. Along with that there is an increment in using financial technology (Fintech) which is online shopping (increase by 2.1 percent in year 2016), internet banking and stock trading (increase by 2.4 percent in year 2016). Thus, internet can be seen as important intermedator for anyone to access the Fintech.

Other than that, Gupta and Xia (2018) stated that technology such broadband that provides internet services has driven revolution in financial services sector whereby its increase along with the Fintech itself. Due to that, this study analyses Fintech variable by proxied it to broadband subscriber.

2.4 Foreign Direct Investment (FDI)

According Ali and Hussain (2017), foreign direct investment (FDI) is defined “as a long-term investment that reflecting a lasting interest by resident entity in one economy. One of the sources of capital inflows to host country is FDI itself (Pandya and Sisombat, 2017). Pandya and Sisombat (2017) stated that FDI inflows considered as crucial

factor for economic growth that can be seen in gross domestic product (GDP), employment, infrastructure improvement, and trade performance. In other word, FDI is likely promoting economic growth for the country that involved (Ali and Hussain, 2017; Lebdaoui and Wild, 2016).

The result from Ali and Hussain (2017) shows positive impact of FDI on economic growth in Pakistan. In case of Australia, result found by Pandya and Sisombat (2017) also shows there is positive impact of FDI on economic growth. However, even though FDI seems contributing positively to economic growth, there is also studies that found otherwise such as studied by Rahman (2015) that found FDI have negative correlation on economic growth in Bangladesh. In addition, there are also studies that found that there is no relationship between FDI and economic growth (Carbonell and Werner, 2018).

2.5 Human Capital

Human capital according to Pindyck and Rubinfeld (2013) is knowledge, skills, and experience that make individual more productive and thereby able to earn a higher income over the lifetime. According to Pelinescu (2015) having proper education and training systems of people that known as human capital is necessary in order to have sustainable development of country that finally can be translated into economic growth itself. Furthermore, finding by Ali, Egbetokun and Memon (2018) also indicates that human capital is robustly and positively correlated with economic growth. Most of the indicator used to represent human capital is enrolment in primary, secondary and tertiary school (Pelinescu, 2015).

3.0 DATA AND METHODOLOGY

This research is an empirical research that analysing data by using panel data of Islamic banks for nine countries which are Saudi Arabia, Malaysia, United Arab Emirates (UAE), Kuwait, Qatar, Turkey, Indonesia, Bahrain and Pakistan started from year 2008 until 2017. Based on Waters (2008), this research is using quantitative analysis method which is using a broad range of numerical approach to solving the problems. Furthermore, based on Babbie, Halley, Wagner, and Zaino (2011), this study is in deductive whereby a logical model in which the investigator begins with a theory and derives hypothesis to be tested by empirical observations. There are three components in Islamic banking namely, Islamic banking asset, Islamic banking financing and Islamic banking deposit. Based on Table 1, there are 68 Islamic banks that involve in this study.

Table 1: Number of Islamic Banks by Country

No.	Country	Islamic Bank
1.	Saudi Arabia	4
2.	Malaysia	16
3.	UAE	7
4.	Kuwait	2
5.	Qatar	5
6.	Turkey	4
7.	Indonesia	7
8.	Bahrain	13
9.	Pakistan	10
Total Islamic Bank		68

Source: Fitch Connect, 2018

3.1 Data descriptions

Based on Table 2 below, its shows that the data are taken from various sources that have an authority in providing the data. There are four main sources in collecting data which is World Bank Data, UNESCO database, Fitch Connect and Data Stream. The duration of data used in this research is from year 2008 to 2017. The reason of gathering dependent variable data started from year 2007 until 2017 is due to 'lag' issue that need one year before to calculate the economic growth. Lastly, all the data will be in natural log value.

Table 2: Measurement of Variables

No.	Variables	Measurement	Period	Sources
1.	Economic growth	Real GDP growth rates	2007- 2017	World Bank Data
2.	Islamic banks	Islamic banking assets Islamic banking financing Islamic banking deposit	2008 – 2017	Fitch Connect
3.	Fintech	Fixed broadband subscriber	2008-2017	World Bank Data and Data Stream
4.	FDI	Foreign direct investment, net inflows	2008-2017	World Bank Data
5.	Human Capital	School enrolment, primary	2008-2017	UNESCO database

3.2 Underpinning Theory

The underpinning theory used as guidelines in this research is Schumpeter's supply-leading theory. In year 1991, Joseph Schumpeter the essential element for economic development is services that provided by financial intermediaries (King and Levine, 1993). The argument by Schumpeter firstly supported by empirical work done by Goldsmith in year 1969 and Mckinnon in year 1973 that illustrating the significant relationship between financial and economic development for few countries (King and Levine, 1993).

Furthermore, according to Patrick, 1966 (as cited in Abduh and Omar, 2012), the Schumpeter's supply-leading theory is explaining on how the creation of financial institutions including instruments that will lead to stimulating the economic growth. In other words, Schumpeter's theory saying is financial development will promotes economic growth. Thus, the findings by Zirek, Celebi and Hassan (2016), Abduh and Omar (2012), Tabash and Dhankar (2014) and Kassim (2016) is align with Schumpeter's supply-leading theory.

Furthermore, this research also aligns with Solow's model. According to Mankiw, Romer and Weil (1992), Solow's model takes the rates of saving, population growth, and technological progress as exogenous. Mankiw et.al (1992) stated that there are two inputs, capital and labor, which are paid their marginal products. Cobb-Douglas production function, so production at time t is given by (Y is output, K capital, L labor, and A the level of technology):

$$Y(t) = K(t)^\alpha (A(t)L(t))^{1-\alpha} \quad 0 < \alpha < 1 \quad (1)$$

In Zirek, Celebi and Hassan (2016) study, they analyses the impact of banking on economic growth by also including inflation, unemployment, capital stock, population growth, interest rate, offshore banking, human capital, government expenditure, agricultural, export value and cell phone. Thus in their full model is written:

$$Growth_i = \beta_0 Q_{i,1999} + \beta_1 ISLMC_{i,t} + \gamma' X_{it} + \varepsilon_{it} \quad (2)$$

In our model,

$$GDP = \beta_0 + \beta_1 IB + \beta_2 Fin + \beta_3 FDI + \beta_4 HC + \mu_{it} \quad (3)$$

Specific model,

$$GDP = \beta_0 + \beta_1 Asset + \beta_2 Fin + \beta_3 FDI + \beta_4 HC + \mu_{it} \quad (4)$$

$$GDP = \beta_0 + \beta_1 Financing + \beta_2 Fin + \beta_3 FDI + \beta_4 HC + \mu_{it} \quad (5)$$

$$GDP = \beta_0 + \beta_1 Deposit + \beta_2 Fin + \beta_3 FDI + \beta_4 HC + \mu_{it} \quad (6)$$

Explanation:

IB = Islamic Bank (assets, financing and deposit)

Fin = Financial Technology (Fintech)

FDI = Foreign Direct Investment (FDI)

HC = Human Capital

3.3 Method

3.3.1 Diagnostic test

3.3.1.1 Normality Test

According Hair, Anderson, Tatham and Black (1998), the basic assumption in analysing data is the variable shape and its correspondence should be distributed normally. There are several ways to check the normality of the data, this research will only focus on Skewness and Kurtosis. The Skewness and Kurtosis are used to test the normality for each variables. The positive Skewness indicates that the distribution with an asymmetric tail toward more positive values while negative Skewness mean the asymmetric tail extending toward more negative values (Cisar and Cisar, 2010). According to Hair, Black, Babin, Anderson and Tatham (2006) suggested that Skewness value should not greater than three while according to Lyes, Ley, Klein, Bernard and Licanta (2013), Kurtosis value should not greater than ten. Thus by having Skewness value less than three and Kurtosis value less than ten, the data can be consider distributed normally.

3.3.1.2 Multicollinearity and Correlation Test

According to Jamal (2017), the multicollinearity will appear when the independence variables in the regression model are highly correlated. As multicollinearity increase, there will be difficult to ascertain the effect of any single variable produce biased estimates of coefficients for regressors because the variables have more interrelationships between each other (Hair et al., 1998). The multicollinearity presence can be checked by using correlation matrix (r) for bivariate analysis between the independent variables and Variance Inflation Factor (VIF). According to Cohen and Cohen (1983), the proposed rule of thumb for presence multicollinearity is the correlation between all independent variables is higher than 0.8. The correlation matrix can be determine by using Pearson and Spearman Correlations. However, according to Hamilton (2012), correlation matrix is not sufficient to detect multicollinearity and it's important to perform VIF in order to ensure there is no collinearity between. According to Hair et al. (1998), if the VIF value is greater than 10, then the model confirm have multicollinearity problem.

3.3.1.3 Heteroscedasticity Test

According to Baum (2001), heteroscedasticity is refer to violation of common assumption in multivariate analysis. The common assumption is homoscedasticity, whereby the error term is the same across all values of the independent variables. One way to detect the problem of heteroscedasticity is using Breusch-Pagan/ Cook-Weisberg test, if the finding is significant ($p < 0.05$) its mean that hypothesis null can be rejected and accept hypothesis alternative which stated that the data is suffers from heteroscedasticity problem. However, if the finding is not significant ($p > 0.05$) its mean the data is homoscedasticity.

3.3.1.4 Autocorrelation Test

Autocorrelation is the issue of error components being correlated across time due to high similarities. On way to detect the existence of autocorrelation is by doing Wooldridge test in model in panel data, if the finding is significant ($p < 0.05$) it means that hypothesis null can be rejected and accept hypothesis alternative that stated that the data suffers from the autocorrelation problem. However, if the finding is not significant ($p > 0.05$) it means the data does not suffer from autocorrelation problem.

3.3.2 Hausman Test

According to Clark and Linzer (2014), Hausman test is advised to be used in order to detect violations of random-effect modelling that explanatory variables are orthogonal to the unit effects. In orther article done by Clark and Linzer (2012) too, they stated that the Hausman test statistic H can be written as:

$$H = (\beta_{RE} - \beta_{FE})' [\text{Var}(\beta_{RE}) - \text{Var}(\beta_{FE})]^{-1} (\beta_{RE} - \beta_{FE})$$

Whereby,

H_0 : Random-effects model is appropriate

H_1 : Fixed-effects model is appropriate

Based on Clark and Linzer (2012), if the finding is significant ($p < 0.05$) it means that hypothesis null can be rejected and accept hypothesis alternative which stated that fixed-effect model is appropriate for the model. However, if the finding is not significant ($p > 0.05$) it means that hypothesis null is failed to reject, thus random-effect model is more appropriate for the model.

3.3.3 Pooled Ordinary Least Square (POLS) test

The method uses to regress the model is Pooled Ordinary Least Squares (POLS) regression. POLS is same as ordinary least squares (OLS), the differences are only POLS is using panel data which mean that the data is including more than one country while OLS is one for a single country. According to Hutcheson (2011), OLS regression is a generalized linear modelling technique that may be used to model a single response variable which has been recorded on at least an interval scale. The relationship between a continuous response variable (Y) and a continuous explanatory variable (X) may be represented using a line of best-fit whereby 'Y' is explain by 'X' (Hutcheson, 2011). The appropriate straight line equation for the linear relationship is represented as:

$$Y = \alpha + \beta x \text{ (single explanatory)}$$

$$Y = \alpha + \beta_1 X_1 + \beta_2 X_2 + \beta_3 X_3 \text{ (multiple explanatory)}$$

The interpretation of the parameters (α and β), α indicates the value of 'Y' when all values of the explanatory variables are zero while β is a parameter that indicates the average change in 'Y' that is associated with a unit change in 'X' (Hutcheson, 2011).

3.3.4 Pearson Correlation

Pearson correlation answers the question either the variables are linearly related. The Pearson coefficient correlation value will determine how strong the relationship between two variables and what direction they correlated either positive or negative (Waters, 2008). Based on Table 3, it shows that there are five main interpretation of Pearson coefficient correlation value which is perfect positive correlated ($r = 1$), positive correlated ($r < 1$), no correlation ($r = 0$), negative correlated ($r < -1$) and perfect negative correlated ($r = -1$). How strong the two variable correlated with each other can be seen through Pearson coefficient correlation value itself. However, to accept the coefficient correlation value the p value must be significant.

Table 3: Interpretation of Pearson Coefficient Correlation

Pearson coefficient correlation	Explanation
$r = 1$	Perfect positive linear relationship
$r < 1$	Positive linear relationship
$r = 0$	There is no correlation at all between the two variables
$r < -1$	Negative linear relationship
$r = -1$	Perfect negative linear relationship

Source: Waters, 2008

5.0 FINDINGS AND DISCUSSION

5.1 Diagnostic Test

The normality test shows all the models do not violate the basic assumption which is the Skewness value did not exceed three while kurtosis value is less than ten. Due to that, the data considered distributed normally. In case multicollinearity and correlation test it shows that the data also does not violate the basic assumption for the three specific model. Unfortunately, based on Table 4, all model is suffer from heteroscedasticity and autocorrelation problemis due to p is significant ($p < 0.05$). Due to that problem, robust regression will be needed during POLS in order to overcome the heteroscedasticity and autocorrelation problem.

Table 4: Heteroscedasticity and Autocorrelation Test

Model/ Test	Wald test (Heteroscedasticity)	Wooldridge test (Autocorrelation)
Model4	0.0000	0.0000
Model5	0.0000	0.0000
Model6	0.0000	0.0000

5.3 Hausman Test

Based on the Table 5, the highest value for the Hausman test is 0.9414 (model 4), followed by 0.5830 (model 5) and 0.4638 (model 6). Thus, the Hausman test shows that the random effect model is more suitable for the all model because of p value is not significant ($p > 0.05$).

Table 5: Hausman Test

Model/ Test	Hausman test
Model4	0.9414
Model5	0.5830
Model6	0.4638

5.4 POLS

Based on Table 6, it shows that Islamic banking has significant contribution on the economic growth which is Islamic banking asset (0.0675***), Islamic banking financing (0.0335***) and Islamic banking deposit (0.0304**). Those coefficients value means, when the Islamic banking asset, Islamic banking financing and Islamic banking deposit increase 1 percent, GDP will increase 0.0675 percent, 0.0335 percent and 0.0304 percent. The highest contributor on the economic growth is Islamic banking asset. Thus, Islamic banking as a whole that represented by Islamic banking asset, Islamic banking financing and Islamic banking deposit contribute positively on economic growth. This result aligns with findings by others researcher such as Zirek, Celebi and Hassan (2016), Boukhatem & Moussa (2017) and Kassim (2016). As stated by Zirek, Celebi and Hassan (2016), Islamic banking has shown to be an effective financial intermediaries (surplus unit to deficit unit) in order to generate economic growth itself. Furthermore, this research finding also supported Schumpeter's supply-leading theory which stated that the creation of financial institutions including instruments (financial development) will stimulating the economic growth.

The Fintech also has significant positive impact on the economic growth that can be seen in Table 4. The coefficients value is 0.1195*, 0.1704*** and 0.1770*** means that, when Fintech increase 1 percent, economic growth will increase 0.1195 percent (model 4), 0.1704 percent (model 5) and 0.1770*** (model 6). The result of Fintech shows that what have been told by Nakaso (2016) it's true whereby he stated that Fintech will eventually contribute on the economic development through the efficiency of finance itself. Other than that, "financial inclusion" that stimulated through Fintech clearly show the positive impact between finance and economy (Nakaso, 2016). In order word, the efficiency of Fintech deliver financial sector into another stage that finally it will positively impact the economic growth. Furthermore, by having access to Fintech, the people can expand their business such as in e-commerce that also can generate economic growth for the country.

Foreign direct investment (FDI) has positive impact on the economic growth. However, it's not significant due to p -value is more than 10 percent for each specific model. The insignificant might due to various reasons such as the duration of study itself. This study only covered started from year 2008 until 2017 compared with Ali and Hussain (2017) that covered started year 1991 until 2015. As stated in literature review, FDI is defined as 'long-term investment', due to that it could be that the range of this study is not enough which is only covered 10 years compared with 25 years study by Ali and Hussain (2017) that found FDI is significantly positively impact on the economic growth. However, there is findings by Carbonell and Werner (2018) that supported this result that stated FDI and economic growth does not have relationship, in other word, FDI is not significantly impact economic growth.

The result of human capital show it's positively impact economic growth. In Table 4, the coefficient value is 0.3676*** (model 4), 0.3864*** (model 5) and 0.3920*** (model 6) means that, when human capital increase 1 percent, the economic growth will increase 0.3676 percent (model 4), 0.3864 percent (model 5) and 0.3920 percent (model 6). As mentioned by Pelinescu (2015), by having proper education and training systems of people that known as human capital, it will lead to sustainable development of country and economic growth itself. Furthermore, this result also associated with the findings found by Ali, Egbetokun and Memon (2018) that stated human capital is related positively with economic growth.

Table 6: Random-Effect Robust POLS

Variables	Model 4 (Asset)	Model 5 (Financing)	Model 6 (Deposit)
Constant	20.5655***	20.5191***	20.4525***
Islamic Banking	0.0675***	0.0335***	0.0304**
FIN	0.1195*	0.1704***	0.1770***
FDI	0.0085	0.0122	0.0125
HC	0.3676***	0.3864***	0.3920***
Observation (n)	80	80	78

Note: ***, **, * indicate significant level at 1%, 5%, and 10% respectively

5.5 Pearson Correlation

Based on Table 7, the Pearson coefficient correlation for Islamic Banking as a whole which is represented by Islamic banking asset, deposit and financing have a positive relationship with Fintech itself. In other words, the development of Islamic bank seems to have a positive relationship with Fintech. The highest Pearson coefficient correlation is 0.7786*** by Islamic banking asset, then it's followed by Islamic banking deposit (0.7567***) and Islamic banking financing (0.7296***). The result also shows that, all Islamic banks (asset, deposit and financing) have relationship with Fintech at 1% significant level. These findings align with idea by Wonglimpiyarat, (2017), Gulamhuseinwala, Bull, Lewis (2015) that stated financial technology can be significant determinant to banking industry's revolution. Wonglimpiyarat, (2017), also added that bank itself is growing along with the technology. In other word, the development of bank is also supported by growing of Fintech too.

Table 7: Relationship between Islamic Banking and Fintech

Rank	Islamic Banking and Fintech (n)	Pearson Coefficient Correlation
1.	Islamic Banking Asset (90)	0.7786***
2.	Islamic Banking Deposit (87)	0.7567***
3.	Islamic Banking Financing (90)	0.7296***

Note: ***, **, * indicate significant level at 1%, 5%, and 10% respectively

6.0 CONCLUSION

The Islamic banking industry has become one of the important factors contributing on economic growth for the selected countries which are Saudi Arabia, Malaysia, UAE, Kuwait, Qatar, Turkey, Indonesia, Bahrain and Pakistan. In addition, this study also found that the development of Islamic banking have significant relationship with Fintech. Thus, the findings indicate that the government need to ensure that the policy and regulation is welcoming the development of Islamic banking. The development of Islamic banking is also important as taking care of the *maslahah* of *ummah* as well to generate the economic growth. As mentioned by Zarrouk, Ghak and Haija (2017), there is a need for the regulators to recognize the potential of Islamic financial development on economic growth even though its only part from financial development.

Generally, the central bank will conduct the monetary policy on behalf of government, while the government in fiscal policies. The monetary policy is a tool used in managing the liquidity through Statutory Reserve Requirement (SRR) and Overnight Policy Rate (OPR) (BNM, 2018). Any increment of SRR and OPR will slow down the development of Islamic banking as well as conventional banking. The influence of monetary policy is verified by a study conducted by Nazi and Masih (2017). Due to that conditions, regulators should also concentrate on developing the Islamic banking within their country by adjusting their policy that can welcome the growth of Islamic banking itself. In that case, monetary policy is the best tools for regulators to manage the growth of Islamic bank. Thus, for example Central Bank can reduce Statutory Reserve Requirement (SRR) and Overnight Policy Rate (OPR) in order for bank to keep growing through their financing modes as well as deposit and asset. Other than that, the additional policy also can be constructed or upgrade the existed policy the related with Islamic Bank such as Islamic Financial Services Act 2013 (example of Malaysia).

In case of Fintech, the finding also shows that there is strong relationship between development of Islamic bank and Fintech. These relationships mean that as Fintech growing, Islamic bank will also growing. Due to that, the regulators need to pay attention on this matters to make sure Fintech itself support the development of Islamic bank. According to Adrian (2018), the Fintech can drive efficiency gains from financial sector, financial deepening, financial inclusion that finally translated to widespread economic as well as social benefits. As mentioned by Adrian (2018), regulators should create a supportive space for new Fintech while maintain the regulatory framework Adrian. As a conclusion, this study has focused on analysing the impact of Islamic banking that represented by Islamic

banking asset, Islamic banking financing and Islamic banking deposit through panel data started from year 2008 until 2017. One of limitations of using panel data is, the outcome result is for the whole selected countries compared using time series that only provide result for only one selecting country. By using time series, the result will be specific to selected country. Therefore, it recommended for the future study to examine the impact of Islamic banking by using time series data for single country. The specific outcome can help policy makers in their own country to adjust their policy accordingly. Other than that, the proxy used to measure Fintech might be difference based on the available data. In this study the closer and suitable proxy for Fintech is internet subscriber. Maybe in the future, there will be availability to another best data for Fintech measurement. If that happened, it is recommended for researchers in future research to update the measurement indicator for Fintech itself. Furthermore, it is also recommended to use other methodology to examine relationship between Islamic banking and economic growth as well as Islamic banking and Fintech such as granger causality test in order to know which direction of causes.

REFERENCES

- Abduh, M. & Omar, M. A. (2012). Islamic banking and economic growth: the Indonesia experience. *International Journal of Islamic and Middle Eastern Finance and Management*, 6(1), pp.35-47.
- Adrian, T. (April 9, 2018). Fintech: Building Trust through Regulation. International Monetary Fund. Retrieved November 10, 2018 from <https://www.imf.org/en/News/Articles/2018/04/11/sp40918-fintech-building-trust-through-regulation>.
- Ali, N. & Hussain, H. (2017). Impact of foreign direct investment on the economic growth of Pakistan. *American Journal of Economics*, 7(4), pp.163-170.
- Ali, M., Egbetokun, A. & Memon, M. H. (2018). Human capital, social capabilities and economic growth. *Economies*, 6(2), pp.1-18.
- Anagnostopoulos, I. (2018). Fintech and Regtech: Impact on Regulators and Banks. *Journal of Economics and Business*, Retrieved October 4, 2018 from <https://doi.org/10.1016/j.jeconbus.2018.07.003>.
- Baum, C. F. (2001). Residual diagnostic for cross-section time series regression models. *The Stata Journal*, 1(1), 101-104.
- Babbie, E., Halley, F. S., Wagner, E. W. & Zaino, J. (2011) *Adventures in Social Research* (7th edition). United States of America: Sage Publications.
- Beard, J. (2016, November 7). How the rise of Fintech could affect your Bank. *The whitlockco*. Retrieved April 21, 2018 from <https://www.whitlockco.com/fin-tech-and-your-bank/>
- Boukhatem, J. & Moussa, F. B. (2017). The effect of Islamic banks on GDP growth: Some evidence from selected MENA countries. *Borsa Istanbul Review*. Retrieved April 21, 2018 <https://doi.org/10.1016/j.bir.2017.11.004>.
- BNM. (2018). *Central Bank of Malaysia Act 2009*. Retrieved October 23, 2018 from http://www.bnm.gov.my/index.php?ch=en_legislation&pg=en_legislation_act&ac=486&lang=en
- Boyes, W. & Melvin, M. (2016). *Macroeconomics (10th edition)*. United States of America: Cengage learning.
- Brue, S. L. & Grant, R. R. (2013). *The Evolution of Economic Thought (8th edition)*. United States of America: Cengage learning.
- Carbonell, J. B. (2018). Does foreign direct investment generate economic growth? A new empirical approach applied to Spain. *Economic Geography*. Retrieved November 3, 2018 from <https://doi.org/10.1080/00130095.2017.1393312>.
- Cisar, P. & Cisar, S. M. (2010). Skewness and Kurtosis in function of selection network traffic distribution. *Acta Polytechnica hungarica*, 7(2), pp.95-106
- Clark, T. S. & Linzer, D. A. (2012). Should I Use Fixed or Random Effects? *Political Science Research and Methods*, 1(1), pp.1-33.
- Clark, T. S. & Linzer, D. A. (2014). Should I Use Fixed or Random Effects? *Political Science Research and Methods*, 1(1), pp.1-10.
- Cohen, J., & Cohen, P. (1983). *Applied Multiple Regression/Correlation Analysis for the Behavioural Science*. Hillsdale, NJ: Erlbaum.
- Gulamhuseinwala, I., Bull, T. & Lewis, S. (2015). Fintech is gaining traction and young, high-income users are the early adopters. *The Journal of Financial Perspectives: Fintech*, 3(3), pp.1-20.
- Gupta, A. & Xia, C. (2018). A Paradigm Shift in Banking: Unfolding Asia's FinTech Adventures. *Banking and Finance Issues in Emerging Markets*, 25(1), pp.215-254.
- Hachicha, N. & Amar, A. B. (2015). Does Islamic bank financing contribute to economic growth? The Malaysian case. *International Journal of Islamic and Middle Eastern Finance and Management*, 8(3), pp.349-368.
- Hamilton, L. (2012). *Statistics with STATA: Version 12*. Canada: Cengage Learning.
- Haddad, C. & Homuf, L. (2018). The emergence of the global Fintech market: economic and technological determinants. *Small Business Economic*, 1(1), pp.1-25.
- Hair, J. F., Black, W. C., Babin, B. J., Anderson, R. E., & Tatham, R. L. (2006). *Multivariate Data Analysis (6th ed.)*. Upper Saddle River, N.J.: Pearson Education Inc.
- Hair, J. F., Anderson, R. E., Tatham, R. L. & Black, W. C. (1998). *Multivariate Data Analysis*. Englewood Cliffs, NJ: Prentice-Hall.
- Hutcheson, G. D. (2011). Ordinary Least-Squares Regression. *The SAGE Dictionary of Quantitative Management Research*, pp. 224-228.
- Imam, P. I. & Kpodar, K. (2016). *Is Islamic Banking Good for Growth?*, IMF Working Paper, WP/15/81, African department.
- Jamal, I. D. (2017). Multicollinearity and regression analysis. *Journal of Physics*. Retrieved November 3, 2018 from [doi:10.1088/1742-6596/949/1/012009](https://doi.org/10.1088/1742-6596/949/1/012009).
- Kassim, S. (2016). Islamic finance and economic growth: The Malaysian experience, *Global Finance Journal*, Retrieved October 4, 2018 from <https://doi.org/10.1016/j.gfj.2015.11.007>.
- King, R. G. & Levine, R. (1992). Finance and growth: Schumpeter might be right. *The Quarterly Journal of Economics*, 108(1), pp.717-737.
- Lebdaoui, H. & Wild, J. (2016). Islamic banking presence and economic growth in Southeast Asia. *International Journal of Islamic and Middle Eastern Finance and Management*, 9(4), pp.551-569.
- Lyes, C., Ley, C., Klein, O., Bernard, P., & Licata, L. (2013). Detecting outliers: Do not use standard deviation around mean, use absolute deviation around median. *Journal of Experimental Social Psychology*, 49(4), pp.764-766.
- Mankiw, N. G., Romer, D. & Weil, D.N. (1992). A Contribution to the empirics of economic growth. *The Quarterly Journal of Economics*, 1(1), pp.407-437.
- Nakaso, H. (2016). *Fintech: its impact on Finance and Central Banking*. Bank of Japan.

- Nazib, N. A. & Masih, M. (2017). The response of monetary policy shocks on Islamic bank deposits: evidence from Malaysia based on ARDL approach. *Munich Personal RePEc Archive*. Retrieved November 10, 2018 from <https://mpra.ub.uni-muenchen.de/82094/>.
- Pandya, V. & Sisombat, S. (2017). Impacts of foreign direct investment on the economic growth: empirical evidence from Australian economy. *International Journal of Economic and Finance*, 9(5), pp.121-131.
- Pelinescu, E. (2015). The impact of human capital on the economic growth. *Procedia Economics and Finance*, 22(1), pp.184-190.
- Pindyck, R. S. & Rubinfeld, D. L. (2013). *Microeconomics (8th edition)*. United States of America: Pearson Education.
- Ramanova, I. & Kudinska, M. (2017). Banking and Fintech: a challenge or opportunity? *Contemporary Studies in Economic and Financial Analysis*, 98(1), pp.21-35.
- Reilly, F.K., Brown, K. C. & Leeds, S. J. (2019). *Investment Analysis and Portfolio Management (11th edition)*. United States: Cengage.
- Rahman, A. (2015). Impact of foreign direct investment on economic growth: empirical evidence from Bangladesh. *International Journal of Economics and Finance*, 7(2), pp.178-185.
- Shamim, F. (2007). The ICT environment, financial sector and economic growth: a cross-country analysis. *Journal of economic studies*, 34(4), pp.352-370.
- Tabash, M. I. and Dhankar, R. S. (2014). Islamic Banking and Economic growth: Cointegration Approach. *Romanian Economic Journal*, 53(17), pp.61-90.
- Todorof, M. (2018). Shariah-compliant FinTech in the banking industry. *ERA Forum*, 19(1), pp.1-17.
- Waters, D. (2008). *Quantitative Methods for Business (4th edition)*. London: Prentice Hall.
- Wonglimpiyarat, J. (2017). FinTech banking industry: a systemic approach. *Foresight*, 19(6), pp.590-603.
- Zarrouk, H., Ghak, T. E. & Haija, E. A. (2017). Financial development, Islamic finance and economic growth: evidence of the UAE. *Journal of Islamic Accounting and Business Research*, 8(1), pp.2-22.
- Zirek, D., Celebi, F. & Hassan, M. K. (2016). The Islamic Banking and Economic Growth Nexus: A Panel VAR Analysis for Organization of Islamic Cooperation (OIC) Countries. *Journal of Economic Cooperation and Development*, 37(1), pp. 69–100.

MEKANISME AGIHAN ZAKAT ASNAF *AL-GHARIMIN* DALAM KALANGAN PESERTA AMANAH IKHTIAR MALAYSIA MELALUI LEMBAGA ZAKAT NEGERI KEDAH (LZNK)

Raziah Md Tahir^{*a}, Syarifah Md Yusof^a & Azizah Othman^a

^a*Islamic Business School, Universiti Utara Malaysia, 06010 Sintok, Kedah Darul Aman, MALAYSIA*

Abstrak

Asnaf al-gharimin merupakan salah satu daripada lapan golongan yang berhak menerima zakat. Menurut Mazhab Syafie, al-gharimin ialah orang yang berhutang sama ada untuk dirinya sendiri atau berhutang demi orang lain dan bertujuan untuk melakukan kebaikan dan ketaatan kepada Allah SWT. Takrifan al-gharimin diperluaskan mengikut keperluan semasa. Setiap institusi zakat negeri pula mempunyai persamaan dan juga perbezaan dalam menentukan kategori asnaf al-gharimin. Peserta Amanah Ikhtiar Malaysia pula merupakan golongan wanita yang menjalankan pelbagai jenis perniagaan secara kecil-kecilan. Ada di antara mereka terpaksa menanggung beban hutang akibat masalah yang dihadapi akibat faktor perniagaan dan bukan perniagaan. Justeru, objektif kertas kerja ini adalah untuk mengkaji tiga perkara utama. Pertama, mengenal pasti takrifan dan kategori asnaf al-gharimin yang diaplikasikan di LZNK. Kedua, mengenal pasti punca kegagalan bayaran balik hutang yang ditanggung oleh peserta AIM. Ketiga, mengenal pasti mekanisme agihan zakat dalam kalangan asnaf al-gharimin di LZNK. Kaedah pengumpulan data dan maklumat adalah secara kualitatif melalui kaedah kajian temu bual bersama informan terpilih di LZNK dan kajian dokumen berkaitan. Hasil kajian ini dapat mengengahkan takrifan dan kategori asnaf al-gharimin secara umum dan kontemporari menurut aplikasi LZNK. Seterusnya kajian ini juga dapat mencadangkan kaedah baharu yang boleh diaplikasikan dalam mekanisme agihan zakat dalam kalangan asnaf al-gharimin.

Kata Kunci: Agihan zakat, asnaf al-gharimin, Amanah Ikhtiar Malaysia dan Lembaga Zakat Negeri Kedah

1.0 PENGENALAN

Amanah Ikhtiar Malaysia (AIM) merupakan sebuah institusi yang menawarkan pembiayaan mikro untuk membantu golongan fakir dan miskin di Malaysia memperolehi modal kewangan bagi memulakan pelbagai projek yang boleh menambah pendapatan. Menurut Muhammad Yunus (1984), skim pembiayaan mikro ini membolehkan isi rumah menggembeng keusahawanan dan kemahiran hidup ke arah peningkatan dalam pendapatan dan taraf hidup. Skim tersebut juga membuka peluang kepada golongan miskin terutamanya kaum wanita untuk memperolehi pembiayaan bagi memulakan perniagaan mereka (Muhammad Yunus, 2007).

Di Malaysia, AIM bermula dengan pelaksanaan projek Ikhtiar pada tahun 1987 melalui sokongan dan bantuan kewangan daripada Kerajaan Persekutuan, Kerajaan Negeri Selangor dan Yayasan Pembangunan Ekonomi Islam (YaPEIM) (Gibbon dan Sukor, 1990). AIM memainkan peranan yang penting dalam penyediaan pinjaman bagi golongan miskin untuk memulakan perniagaan secara kecil-kecilan terutamanya di kawasan luar Bandar (Chan, 2005). Md. Shahid (1996) turut menyokong bahawa melalui skim pembiayaan kredit mikro AIM, kemiskinan dalam kalangan penduduk luar bandar juga dapat dikurangkan melalui peningkatan pendapatan purata isi rumah yang menceburkan diri dalam bidang perniagaan. AIM juga telah berjaya membantu wanita miskin melalui falsafah, konsep dan pendekatan kredit mikro (Nor Aini Haji Idris, 1999).

Lembaga Zakat Negeri Kedah (LZNK) merupakan sebuah institusi zakat negeri yang memainkan peranan penting dalam hal ehwal berkaitan pungutan dan agihan zakat di negeri Kedah. Dalam memastikan matlamat dan fungsi penubuhan Lembaga Zakat Negeri Kedah (LZNK) berada pada landasan yang betul, visi dan misi LZNK menjadi panduan supaya pentadbiran kutipan dan agihan zakat terus berkembang dengan pesat sekaligus membantu asnaf di negeri Kedah ini untuk keluar daripada kepungung kemiskinan. Visi LZNK adalah untuk menjadi sebuah agensi pengurusan zakat yang unggul dan bertaraf dunia. Manakala misi LZNK adalah untuk mengurus dan meningkatkan operasi kutipan dan agihan zakat di negeri Kedah dengan berintegriti bagi pembangunan sosio ekonomi ummah (LZNK, 2020). Dengan slogan "Asnaf disantuni, pembayar diberkati" menjadi daya penarik kepada semua golongan masyarakat untuk sama-sama membantu merealisasikan visi dan misi LZNK.

Dalam kes AIM, peserta membuat pembiayaan daripada AIM melalui borang permohonan pembiayaan dan ianya terbuka kepada semua golongan miskin tanpa mengira kaum, agama dan fahaman politik (AIM, 2006). Peserta yang telah memperolehi pembiayaan dikehendaki membayar balik pembiayaan tersebut mengikut tempoh yang dipilih secara mingguan. Sekiranya mereka tidak dapat menyelesaikannya dalam tempoh tersebut, peserta lain dalam kumpulan yang sama perlu membantu menjelaskannya terlebih dahulu. Peserta juga diberi peluang untuk melanjutkan lagi tempoh bayaran balik sehinggalah kesemua bayaran balik dapat dilangsaikan. Namun begitu, perlanjutan tempoh tersebut akan menyebabkan permohonan peserta lain yang ingin membuat pembiayaan terganggu. Persoalannya, sejauhmanakah peserta AIM yang tidak mampu menjelaskan bayaran balik hutang ini boleh dikategorikan sebagai asnaf al-gharimin? Adakah terdapat mekanisme tertentu dalam agihan zakat di LZNK kepada peserta AIM tersebut? Oleh itu, kertas kerja ini cuba meneliti takrifan dan kategori asnaf al-gharimin di LZNK, punca kegagalan bayaran balik hutang dalam kalangan peserta AIM dan mekanisme agihan zakat dalam kalangan asnaf al-gharimin di LZNK.

2.0 METODOLOGI KAJIAN

Kertas kerja ini membincangkan sebahagian daripada hasil penyelidikan Geran FRGS. Memandangkan kertas kerja ini ingin melihat mekanisme agihan zakat dalam kalangan asnaf al-gharimin di LZNK, beberapa perkara penting perlu diuraikan terlebih dahulu. Pertama berkenaan takrifan dan kategori asnaf al-gharimin terutamanya di LZNK. Kedua, punca kegagalan bayaran balik hutang dalam kalangan peserta AIM. Ketiga, mekanisme agihan zakat dalam kalangan asnaf al-gharimin di LZNK. Proses temu bual dijalankan terhadap peserta AIM yang telah menerima pembiayaan untuk menjalankan perniagaan dan pelbagai aktiviti ekonomi yang mendatangkan sumber pendapatan. Cawangan AIM di Kedah yang terpilih dalam temu bual ini adalah Cawangan Kubang Pasu dan Langkawi. Soalan temu bual merangkumi soalan berkaitan maklumat latar belakang peserta, maklumat produk pembiayaan yang dipohon, isu dan masalah yang dihadapi peserta dan penyelesaian terhadap masalah yang dihadapi. Namun kertas kerja ini hanya membincangkan tentang punca kegagalan bayaran balik hutang peserta AIM. Setelah mengetahui punca kegagalan bayaran balik hutang dalam kalangan peserta AIM, pengkaji cuba meneliti mekanisme agihan zakat dalam kalangan asnaf al-gharimin di LZNK. Mekanisme agihan zakat ini meliputi kaedah dan bentuk bantuan yang boleh diberikan kepada asnaf al-gharimin. Kaedah pengumpulan maklumat berkaitan mekanisme agihan zakat tersebut diperolehi daripada laman portal rasmi LZNK dan juga temu bual bersama pihak LZNK.

Data dan maklumat yang diperolehi daripada temu bual informan dan dokumen-dokumen berkaitan daripada laman portal rasmi AIM dan LZNK dianalisis secara analisis kandungan bersesuaian dengan objektif kertas kerja ini. Informan temu bual terdiri daripada pihak pengurusan AIM, peserta AIM dan pihak pengurusan Bahagian Agihan di LZNK.

3.0 TAKRIFAN DAN KATEGORI ASNAF AL-GHARIMIN

Setiap institusi zakat negeri di Malaysia mempunyai takrifan tersendiri berkenaan asnaf al-gharimin seperti mana yang disenaraikan dalam Jadual 1.

Pusat Urus Zakat/ Lembaga Zakat/ Jabatan Zakat/ Baitulmal Negeri	Takrifan dan kategori asnaf al-gharimin
Perlis	Orang yang berhutang untuk memenuhi keperluan asas bagi kemaslahatan diri, keluarga, tanggungannya atau masyarakat Islam yang memerlukan penyelesaian segera dan dibenarkan oleh hukum syarak.
Kedah	Orang yang berhutang untuk kepentingan bukan maksiat dan tidak mampu membayarnya. Ada pun orang yang berhutang untuk memelihara persatuan umat Islam dibayar hutangnya itu dengan zakat, walaupun ia mampu membayarnya.
Pulau Pinang	Kesusahan berat/hutang, rawatan kronik/dialisis, yuran STAM/STPM, pengurusan jenazah tak berwaris, baik pulih pondok pengajian dan sumbangan kepada institusi khas (Sek. Terencat Akal/ Anak Yatim/ Buta/ Pekak).
Perak	Bantuan menyelesaikan hutang pendaftaran di pusat pengajian tinggi dalam negeri, hutang tambang tiket kapal terbang dan sebagainya serta bayaran balik pinjaman berjadual kepada Kerajaan Negeri. Pemohon hendaklah mengemukakan bukti keterhutangan dan menunjukkan ikhtiar dan usaha yang telah dibuat untuk menyelesaikannya sebelum membuat permohonan tersebut. Hutang untuk perkara yang bukan untuk kepentingan syarie atau keperluan syarie atau keperluan untuk bermewah akan ditolak.
Selangor	Hutang kerana keperluan hidup, hutang persatuan kerana permasalahan ummah, hutang rawatan mesin dialisis, hutang perubatan dan pengurusan jenazah tanpa waris.
Wilayah Persekutuan Negeri Sembilan	Orang yang menanggung hutang untuk tujuan yang bukan maksiat dan tidak mampu menyelesaikannya Golongan yang berhutang untuk memenuhi keperluan asas bagi kemaslahatan diri, keluarga, tanggungannya atau masyarakat Islam yang memerlukan penyelesaian segera dan dibenarkan oleh hukum syarak.
Melaka	Orang yang menanggung hutang yang dibenarkan oleh syarak seperti hutang untuk masalah orang ramai tetapi tidak mampu membayar hutang tersebut.
Johor	Golongan yang berhutang untuk memenuhi keperluan asas diri, keluarga, tanggungannya atau masyarakat

Pahang	dan memerlukan penyelesaian segera selaras dengan hukum syarak. Golongan yang berhutang untuk memenuhi keperluan asas diri, keluarga, tanggungannya atau masyarakat dan memerlukan penyelesaian segera yang dibenarkan syarak
Terengganu	Golongan yang berhutang untuk memenuhi keperluan asas bagi kemaslahatan diri, keluarga, tanggungannya atau masyarakat Islam yang memerlukan penyelesaian segera dan dibenarkan oleh hukum syarak.
Kelantan	Orang-orang berhutang untuk faedah awam seperti untuk menghapuskan persengketaan dua pihak dan sebagainya. Bagi individu yang berhutang untuk tujuan peribadi, mereka hanya boleh dimasukkan ke dalam asnaf ini dengan syarat beliau mestilah tidak memiliki harta dalam kadar yang mencukupi (<i>haddul kifayah</i>).
Sabah	Orang yang berhutang untuk tujuan bukan maksiat, bantuan perubatan dan rawatan, pengurusan jenazah, bantuan baik pulih surau dan masjid, bantuan kepada Sekolah Agama Rakyat, Pertubuhan Bukan Kerajaan dan Tajaan program Islamik.
Sarawak	Orang yang terpaksa berhutang disebabkan keperluan mendesak yang tidak berlebihan-lebihan bagi diri dan masyarakat Islam yang bukan kerana maksiat (<i>nafsu</i>).

Sumber: Diubah suai berdasarkan maklumat yang diakses dari laman web Pusat Zakat negeri-negeri yang berkenaan.

Berdasarkan Jadual 1, didapati takrifan asnaf al-gharimin di LZNK adalah agak umum dan tidak dipecahkan kepada kategori tertentu. Berdasarkan temu bual dengan pihak LZNK di Bahagian Agihan Zakat, mereka yang berhutang dan mempunyai masalah dalam membayar balik hutang dibenarkan memohon bantuan daripada LZNK dengan mengisi borang secara manual. Borang tersebut boleh diperolehi daripada Imam Masjid di setiap Kariah masing-masing. Pihak LZNK seterusnya akan menyelidik latar belakang pemohon terlebih dahulu dan bantuan hanya diberikan kepada pemohon yang benar-benar layak berdasarkan keperluan daruriyyah yang tidak bertentangan dengan syarak.

4.0 PUNCA KEGAGALAN BAYARAN BALIK HUTANG PESERTA AIM

Bahagian ini membincangkan masalah berkaitan perniagaan yang dihadapi oleh para peserta yang mempengaruhi proses bayaran balik hutang pembiayaan masing-masing. Berdasarkan temu bual dengan peserta AIM, hasil kajian mendapati terdapat tujuh klasifikasi masalah yang dihadapi oleh peserta AIM dalam menjalankan perniagaan masing-masing. Masalah tersebut termasuklah kekurangan sumber bekalan, masalah pelanggan, pengurusan kewangan, pengurusan pemasaran, aset niaga rosak, kenaikan harga barang dan masalah kesihatan. Masalah yang dihadapi ini menjadi punca terhadap kegagalan bayaran balik hutang peserta AIM.

4.1 Kekurangan Sumber Bekalan

Masalah kekurangan sumber bekalan di sini merujuk kepada situasi kekurangan sumber bahan mentah oleh peniaga bagi menghasilkan produk akhir perniagaan untuk dijual kepada pengguna. Bagi sesetengah produk di pasaran, sekiranya masalah ini berterusan, kekurangan bekalan bukan hanya dirasai oleh para peniaga, tetapi juga para pengguna akan turut terjejas.

4.2 Pengurusan Kewangan

Pengurusan kewangan adalah salah satu cabang ilmu yang perlu dikuasai oleh setiap usahawan mahupun peniaga kecil-kecilan untuk berjaya dalam bidang perniagaan. Secara umumnya, pengurusan kewangan meliputi pengurusan ke atas modal, belanjawan perniagaan, hasil dan keuntungan perniagaan.

4.3 Pengurusan pemasaran

Pengurusan pemasaran merupakan aktiviti bagi menyampaikan produk atau perkhidmatan dari pengeluar atau peniaga kepada pengguna akhir dalam pasaran. Fungsi pemasaran pula dilaksanakan berdasarkan 4P's dalam perniagaan. 4P's tersebut adalah produk, promosi, tempat dan harga (*product, promotion, place and price*). Berdasarkan analisis temu bual mendapati masalah pemasaran yang dihadapi oleh para peserta AIM adalah berpunca dari produk perniagaan yang kurang jelas dan promosi yang kurang berkesan.

4.4 Aset perniagaan rosak

Terdapat juga masalah perniagaan yang disebabkan peralatan atau fasiliti perniagaan rosak. Aset perniagaan tersebut merupakan perkara yang sangat penting kepada peniaga. Sekiranya aset perniagaan rosak, ia memdatangkan bebanan kos kepada pihak peniaga. Pembelian aset perniagaan yang baharu akan meningkatkan kos dan memdatangkan kesulitan kepada pihak peniaga untuk terus beroperasi.

4.5 Kenaikan harga barang mentah

Kedadaan ekonomi yang mendorong kenaikan harga barang mentah kepada penghasilan produk akhir pengguna

selalunya menjadi masalah buat peniaga kecil-kecilan seperti peserta AIM. Sasaran pasaran mereka yang kebanyakannya hanya di kawasan kampung dan terpencil sudah semestinya memerlukan mereka meletakkan harga jualan pada tahap yang sederhana.

4.6 Kesihatan

Masalah yang terakhir dalam hasil kajian ini adalah masalah yang berlaku terhadap diri peniaga itu sendiri iaitu masalah kesihatan. Lebih merumitkan lagi jika masalah kesihatan turut berlaku dalam kalangan ahli keluarga peserta itu sendiri.

4.7 Masalah Rakan Ahli Peserta

Hasil analisis mendapati tiada masalah pembayaran yang dihadapi oleh individu setiap peserta yang ditemubual, tetapi rakan ahli AIM yang mempunyai masalah dalam menjalankan tanggungjawab mereka untuk membayar hutang. Oleh itu, sebagai rakan ahli, peserta AIM yang ditemubual haruslah membayar bagi pihak rakan yang menghadapi masalah tersebut.

5.0 MEKANISME AGIHAN ZAKAT DALAM KALANGAN ASNAF AL-GHARIMIN DI LZNK

Mekanisme agihan zakat merujuk kepada kaedah tertentu yang merangkumi program pembangunan asnaf, program agihan dan bentuk bantuan zakat yang diberikan kepada asnaf zakat. Terdapat lima program pembangunan asnaf yang dilaksanakan oleh LZNK iaitu pusat kemahiran jahitan, usahawan zakat Kedah, latihan dan kemahiran untuk anak asnaf, pondok moden zakat Kedah dan *free market@zakat* Kedah. Terdapat empat program agihan iaitu Pusat Homodialisis zakat, Pusat Bimbingan dan Latihan Saudara Baru (PUSBA), program pendidikan dan program kemasyarakatan. Terdapat tujuh bentuk bantuan zakat yang disediakan oleh LZNK iaitu bantuan sara hidup, perubatan, perumahan, perniagaan/jaya diri, musibah alam, pembangunan ummah dan pendidikan.

Berdasarkan kepada temubual bersama pihak pengurusan LZNK di bahagian agihan, asnaf al-gharimin adalah layak menerima bantuan di bawah salah satu program agihan yang disediakan oleh pihak LZNK. Untuk tujuan tersebut, mereka perlu mengisi borang permohonan bantuan zakat terlebih dahulu. Setelah itu, pihak LZNK akan menyiasat latar belakang pemohon berdasarkan maklumat yang telah diisi di dalam borang permohonan tersebut. Sekiranya layak, pihak LZNK akan menghubungi para pemohon untuk memaklumkan status permohonan mereka.

Dalam kes hutang peserta AIM yang tidak mampu menjelaskan bayaran balik pembiayaan, setakat ini masih belum ada rekod berkenaan peserta AIM yang menghadapi masalah untuk membayar hutang telah memohon bantuan zakat di LZNK. Namun, terdapat permohonan bantuan zakat al-gharimin dalam kalangan peminjam-peminjam 'Ah Long'. Kategori pinjaman 'Ah Long' ini tidak termasuk dalam berhutang patuh syariah memandangkan urusan hutang piutang tersebut melibatkan unsur riba yang diharamkan dalam Islam. Justeru, pihak LZNK hanya dapat memberi bantuan kepada mereka yang mempunyai anak-anak yang masih bersekolah atau atas sebab kesihatan yang dibenarkan dalam mana-mana kategori asnaf.

Sekiranya peserta AIM mengalami kegagalan dalam perniagaan dan bermasalah dalam menyelesaikan urusan bayaran balik hutang dengan pihak AIM, mereka boleh memohon bantuan zakat di bawah asnaf al-gharimin. Setelah dinilai kelayakan pemohon oleh LZNK, mereka akan diberikan bantuan wang tunai secara sekaligus mengikut jumlah yang dipersetujui pihak LZNK. Selain itu, LZNK juga boleh memberikan bantuan perniagaan dalam bentuk pembelian mesin atau alat kelengkapan perniagaan yang bersesuaian bagi peserta AIM bagi menggantikan bantuan wang tunai.

6.0 KESIMPULAN

Secara ringkasnya, pembiayaan mikro yang dilakukan oleh peserta AIM merupakan satu bentuk hutang Islam yang wajib dijelaskan bayaran balik setelah cukup tempoh seperti mana yang dipersetujui oleh kedua-dua pihak AIM dengan peserta AIM. Kontrak pembiayaan mikro yang diaplikasikan dalam pembiayaan mikro ini merupakan satu kontrak Islamik yang dikenali sebagai *Murabahah Komoditi*. Justeru, pembayaran balik pembiayaan dalam kalangan peserta AIM juga seharusnya mematuhi kehendak syarak. Sekiranya peserta AIM mengalami masalah dalam bayaran balik pembiayaan, peserta masih boleh berbincang dengan pihak AIM untuk menjadualkan semula ansuran bayaran balik pembiayaan tersebut. Sekiranya masih gagal berbuat demikian, peserta AIM perlulah memaklumkan kepada pihak AIM dengan kadar segera. Peserta AIM yang benar-benar mengalami kesempitan wang untuk menjelaskan hutang atas sebab *daruriyyah* boleh menghubungi pihak LZNK untuk memohon bantuan zakat asnaf *al-gharimin*. Hal yang demikian sekaligus dapat meringankan beban hutang peserta AIM dan pihak AIM juga dapat

terus menawarkan pembiayaan kepada peserta AIM yang lain dalam membantu golongan tersebut meningkatkan taraf hidup melalui aktiviti perniagaan yang halal di sisi syarak. Di samping itu pihak AIM juga boleh bekerjasama dengan pihak LZNK dari aspek menyalurkan maklumat terkini mengenai peserta AIM yang mengalami masalah kritikal dalam membayar balik hutang mereka. Hal yang demikian memudahkan pihak LZNK menyiasat latar belakang peserta tersebut sama ada mereka layak atau pun tidak untuk mendapat bantuan zakat di bawah asnaf *al-gharimin*. Untuk tujuan tersebut, peserta AIM perlulah mengisi borang permohonan bantuan zakat terlebih dahulu bagi memudahkan urusan agihan zakat oleh pihak LZNK kepada golongan yang benar-benar layak menerima bantuan zakat.

PENGHARGAAN

Penulis mengucapkan setinggi-tinggi penghargaan kepada Kementerian Pendidikan Malaysia (DP KPM)-FRGS (Kod s/o: 13026) di atas penawaran Dana Geran sebanyak RM78,900 untuk penyelidikan ini yang bertajuk “Peranan zakat dalam penyelesaian hutang asnaf *al-gharimin* dalam kalangan peserta Amanah Ikhtiar Malaysia”. Kami juga mengucapkan terima kasih kepada semua pihak yang telah menyumbang kepada kejayaan menyempurnakan penyelidikan FRGS ini.

RUJUKAN

- Abdullah al-Mamun *et al.* (2011). “Empirical Investigation on Repayment Performance of Amanah Ikhtiar Malaysia’s Hardcore Poor Clients” dlm. *International Journal of Business and Management*, Vol. 6, No. 7, hal. 125-133.
- AIM (Amanah Ikhtiar Malaysia) (2006). “Dua Dekad IKHTIAR Menjunjung Amanah” dlm. *Jurnal IKHTIAR*, Edisi Khas AIM 20 Tahun, Januari-Mac 2006, hal. 1-42.
- Al-Quran, Mushaf Malaysia dan Terjemahan* (2006). Shah Alam: Yayasan Restu.
- Azlan Khalili Shamsuddin (1995). *Riba: Alternatifnya Dalam Sistem Bank Islam*. Kuala Lumpur: Dewan Bahasa dan Pustaka.
- Chan, S.H (2005). “An Explonatory Study of Using Micro-Credit to Encourage the Setting up of Small Businesses in the Rural Sector of Malaysia” dlm. *Asian Business & Management*. Vol 4. Iss. 4, hal. 455.
- Gibbons, D.S dan Sukor Kasim (1990). *Banking on The Rural Poor*. Penang: Center for Policy Research, Universiti Sains Malaysia.
- Lembaga Zakat Negeri Kedah (LZNK) (2020). “Agihan Bantuan” di akses dari laman portal rasmi LZNK (zakatkedah.com.my) pada 1 September 2020.
- Md. Shahid Hassan (1996). *The Role of Amanah Ikhtiar Malaysia in Rural Poverty Alleviation: A Study in Sabak Bernam District, Selangor*. Tesis Sarjana Ekonomi yang diserahkan kepada Fakulti Ekonomi dan Perniagaan. Universiti Kebangsaan Malaysia. Tidak diterbitkan.
- Muhammad Yunus (1984). *On Reaching The Poor*. Dhaka: Grameen Bank.
- Muhammad Yunus (2003). *Banker To The Poor: Micro Lending and The Battle Against World Poverty*. New York: Public Affairs.
- Muhammad Yunus. (2007). *Banker To The Poor : Micro-Lending and The Battle Against World Poverty*. New York: Public Affairs.
- Muhammad Yunus (2007). *Creating a World Without Poverty : Social Business and The Future of Capitalism*. New York: Public Affairs.
- Mustofa Al-Khin, Dr. Mustofa Al-Bugho & Ali Asy-Syarbaji. (2004). “Fiqh Mazhab Syafie.” *Terjemahan Ust. Solehan bin Ayub*. Shah Alam: Pustaka Salam Sdn. Bhd.
- Neuman, W.L. (2006). *Social Research Methods: Qualitative and Quantitative Approaches* (6th Edition). New York: Pearson Education Inc.
- Noraini Idris (2010). *Penyelidikan dalam Pendidikan*. Kuala Lumpur: Mc Graw Hill.
- Norhaizah Nawai & Mohd Noor Mohd Shariff (2010). “Determinants of Repayment Performance in Microcredit Programs: A Review of Literature” dlm. *International Journal of Business and Social Science*, Vol. 1. No. 2. Hal. 152-160.
- Norhaizah Nawai & Mohd Noor Mohd Shariff (2011). “The Importance of Micro Financing to the Microenterprises Development in Malaysia’s Experience” dlm. *Asian Social Science*, Vol. 7. Hal. 226-238.
- Osman Sabran (2000). *Urusniaga Al-Bai’ Bithaman Ajil Dalam Mekanisme Pembiayaan Tanpa Riba*. Skudai: Penerbit Universiti Teknologi Malaysia.
- Osman Sabran (2001). *Urusniaga al-Qard al Hasan Dalam Mekanisme Pembiayaan Tanpa Riba*. Skudai: Penerbit Universiti Teknologi Malaysia.
- Sekaran, Uma (2003). *Research Methods for Business: A Skill Building Approach*, 4th Edition. New York: John Wiley & Sons Inc.
- Sekaran, Uma dan Bougie, R. (2010). *Research Methods for Business*, Fifth Edition. United Kingdom: John Wiley & Sons Inc.
- Temu bual dengan Pihak Pengurusan AIM di Ibu Pejabat Amanah Ikhtiar Malaysia, Damansara Kuala Lumpur pada 5 Mei 2017 jam 3.00 petang.
- Temu bual dengan peserta AIM Cawangan Langkawi di Lubuk Setol, Langkawi pada 25 Mac 2016 jam 9.00 pagi.
- Temu bual dengan peserta AIM Cawangan Kubang Pasu di Pusat Internet 1Malaysia Jerlun, pada 9 Ogos 2016 jam 10.30 pagi.
- Temu bual dengan Pihak Pengurusan AIM (Pegawai AIM) di Ibu Pejabat AIM, Damansara secara atas talian pada 27 November 2017 jam 11.57 pagi.
- Temu bual dengan Pihak Lembaga Zakat Negeri Kedah (LZNK), Bahagian Agihan di Ibu Pejabat LZNK, Alor Setar Kedah secara atas talian pada 20 September 2020 jam 3.30 petang.
- Wahbah al-Zuhaili (1995). *Fiqh dan Perundangan Islam*. Terjemahan Md Akhir Haji Yaacob et al. Jilid IV. Kuala Lumpur: Dewan Bahasa dan Pustaka.
- Wahbah al-Zuhaili (1996). *Fiqh dan Perundangan Islam*. Terjemahan Md Akhir Haji Yaacob et al. Jilid IV. Kuala Lumpur: Dewan Bahasa dan Pustaka.
- Yusuf al-Qardhawi (2007). *Halal dan Haram Menurut Perspektif Islam*. Terj. Abu Jabir Muhammad Pattani: Bin Halani Press.

THE ADMINISTRATIVE CONSEQUENCES OF ARMED CONFLICT AND THEIR IMPACT ON TECHNICAL AND VOCATIONAL EDUCATION AND TRAINING (TVET) AN APPLIED STUDY IN COMMUNITY COLLEGES IN YEMEN

التداعيات الإدارية للنزاع المسلح وتأثيرها في التعليم والتدريب المهني والتقني
دراسة تطبيقية في كليات المجتمع في اليمن

Nashwan Taqiaddin^{*a}, Esmail Al-Moshiki.^b, Mohamed Battour, Muhammad Khairi

^aFirst affiliation, YEMEN

^bSecond affiliation, YEMEN

Third affiliation, Egypt

fourth affiliation, Malaysia

الملخص

في منتصف العقد الثاني من القرن الحادي والعشرين، شهد العالم نزاعات مسلحة في اليمن، والتي لا تزال مستمرة حتى الآن. سبب هذا النزاعات مأساة مؤلمة على الأرض والإنسان. تهدف هذه الدراسة إلى تحديد التداعيات الإدارية للنزاع المسلح وتأثيرها في جودة خريجي التعليم والتدريب المهني والتقني.

استخدمت هذه الدراسة المنهج المختلط (كمي-نوعي). تم أخذ عينة الدراسة الكمية بطريقة احتمالية. تتألف العينة من (615) شخصاً، من بينهم 60 مدرساً و66 موظفاً و489 طالباً.

تم إجراء تحليل البيانات الاستكشافية باستخدام SPSS. وتم استخدام برنامج التحليل الإحصائي (AMOS) لإجراء التحليل العاملي التوكيدي، وبواسطة معادلة النمذجة الهيكلية (SEM)؛ تم تحليل مسار العلاقات بين متغيرات الدراسة، والتحقق من الصدق بجميع أنواعه، ومن الموثوقية المركبة، واعتمدت الدراسة النوعية على مقابلات مع ثلاث مجموعات بؤرية من الأكاديميين والموظفين المرتبطين بالتعليم والتدريب المهني والتقني، وشملت 14 أكاديمياً وموظفاً. وخلصت الدراسة إلى النتائج التالية: إلى أن هناك عواقب سلبية مباشرة للنزاع المسلح تؤثر في جودة خريجي التعليم والتدريب المهني والتقني.

الكلمات المفتاحية: التداعيات، النزاع المسلح، جودة الخريجين، التعليم والتدريب المهني والتقني.

Abstract

In the middle of the second decade of the 21st century, the world witnesses armed conflicts in Yemen, that is incessant until now. These conflicts cause painful tragedies on the land and human. The study aims to identify the consequences of armed conflict and its impact in the quality of graduates of technical education and vocational training (TEVT).

This study used a mixed method quantitative and qualitative; the quantitative study sample was taken in a probabilistic way. The sample consists of (615) respondents, including 60 teachers, 66 employees, and 489 students. Exploratory data analysis was performed using SPSS. The Statistical Analysis Program (AMOS) was used to perform confirmatory factor analysis, and through the structural modelling equation (SEM), the path of constructing relationships between study variables, checking all kinds of validity, and compound reliability was analysed.

The qualitative study relied on interviews with three focus groups of academics and staff related to (TEVT), included 14 academics and staff. The study concluded the following results: there are Direct negative consequences of armed conflict affecting the quality of TEVT graduates

Keywords: consequences, armed conflict, graduate quality, (TEVT).

•

1. المقدمة

يعتبر التعليم مصباح إنارة دروب السير الأمن في ظلمات دروب الحياة، وبه يتمتع الإنسان بمدارك كامنة، لا يمكن معرفتها إلا إذا عبر عنها بالأفكار التي يحملها، والتي تعكس ما لديه من علوم ومدارك ناطقة، ويمثل التعليم الأسس التي ترتكز عليه تلك المدارك، وبها ينمي العنصر البشري الذي تربطه علاقة قوية بزيادة الاستثمارات الموجهة له وبالنمو الاقتصادي في أي كيان، فتنمية العنصر البشري بشقيها المادي والمعنوي وحتى العلاقات البيئية مرتكزاها الأساسي هو التعليم (عمر، وحميد، 2015؛ وKotite, 2012).

وتدور كثير من معاني التعليم حول نظام التعليم الكفؤ والمنصف، والملائم والفعال في محيط بيئته، ويتجلى تأثير التعليم في مدى توافق وانسجام العلاقة بين أهداف نظام التعليم ومنتجاته واحتياجات البيئة التي يعمل فيها، وهذا ما يطلق عليه الكفاءة والفاعلية، والتي تستند إلى العلاقة بين المخلات أو الموارد من ناحية والمنتجات أو النتائج من ناحية أخرى، وفق توزيع منصف للموارد والمنتج التعليمية (Valle, 2018). ويعتبر التعلم منذ القدم مصدرًا لكل التقدم في المجتمعات (Ancori, 2016).

ولهذا صار التعليم باباً للتقدم المعرفي والتنموي في هذا العصر الذي تتدفق فيه المعلومات بصورة هائلة عبر ثورة الاتصالات التي تخطت حواجز الزمان والمكان في شتى مجالات الحياة، ومرتکز سيادة الحضارات قديماً وحديثاً هو العلم والعمل، بل إن جل الدول التي أحرزت شوطاً كبيراً في التقدم، ما كان تقدمها إلا من بوابة التعليم (Diwakar, 2015).

ومن الكتاب من أشار إلى أن المجتمعات التي حققت تقدم في مضممار الحضارة جعلت أولويتها للمدارس قبل المصانع وللكتب قبل الآلات، لأن التعليم هو أساس تطور المعرفة ونمو سبل المعيشة الكريمة من خلال القوات التي يؤثر عبرها التعليم إيجابياً في العملية التنموية، وخاصة تأثيراته البيئية والتي تتعكس على الحالة الاقتصادية، والصحية، والاجتماعية، والإدارية، والأمنية، ونظم الحكم الديمقراطي (أبو، 2015؛ و عمر، وحميد، 2015). لقد صار التعليم في العصر الحاضر مقياس يقاس به قدرة الأمم، وتقيم على ضوءه مواردها البشرية من خلال مستوى التأهيل والتدريب النوعي المتصف بالقدرة على التكيف والتعامل مع مستجدات العصر وتقنياته بكفاءة وفاعلية (إبراهيمي، 2013).

وتتضح أهمية التعليم في الإنتاج والإبداع في شتى مجالات الحياة وعلومها، بالإضافة إلى المهارات الحياتية التي يتمتع بها أفراد المجتمع، ويقوم مدى التقدم المحرز في المجتمعات وفق أربعة أبعاد، هذه الأبعاد هي: البعد المعرفي من خلال التعلم للمعرفة، والبعد الأدائي من خلال التعلم للعمل، وبعد التكوين الذاتي من خلال تعلم لتكون، والبعد الاجتماعي من خلال تعلم العيش المشترك (اليونسكو، 2018).

والتعليم الفني هو "ذلك النوع من التعليم النظامي الذي يتضمن الإعداد التربوي وإكساب المهارات والمعرفة المهنية، الذي تقوم به مؤسسات تعليمية نظامية من أجل إعداد عمال مهرة في مختلف التخصصات الصناعية والزراعية والصحية والتجارية والخدمية (Ministry of Higher Education, 2017). لتكون لديهم القدرة على التنفيذ والإنتاج بحيث يكونون حلقة وصل مهمة بين الأطراف الفنية العالية الذين تعدهم الجامعات والعمال غير المهرة الذين لم يتلقوا أي نوع من التعليم النظامي الفني والمهني" (حليبي، 2012).

وتسهم جودة هذا النوع من التعليم في تطور مجموعة القدرات الشخصية والعلاقات الفعالة التي يمتلكها المتعلم ويتميز بها، كما يعزز هذا النوع من التعليم قدرات الأفراد على تبني ممارسات ذات قيمة اجتماعية، حتى تسهم تلك القدرات في تطوير المجتمع ورفع مجالات الاقتصاد فيه، كما يسهم أيضاً في توفير المعرفة على نطاق واسع، من خلال ضمان التفكير الإبداعي الناقد والمنتج، في العصر المعرفي الذي تهيمن عليه تكنولوجيا المعلومات والاتصالات (Hrmo, et. Al, 2015).

ولأهمية هذا النوع من التعليم فقد تبنت التجربة الألمانية استجابة علمية وعملية لواقع ما بعد الحرب العالمية الثانية، حيث تم استحداث المعاهد الفنية العالية كمؤسسات تعليمية تساهم في تطوير الصناعات الألمانية، وتعزيز قدرتها التنافسية في السوق العالمية، حيث يعدّ التعليم والتدريب المهني والتقني في ألمانيا من أرقى المستويات التعليمية على مستوى العالم، وله دور بارز في التخلص من الخراب الاقتصادي الذي خلفته الحروب، ومكن من تحقيق النمو الذي عُدّت بموجبه ألمانيا من بين أكبر عشر دول صناعية في العالم رغم افتقارها للمواد الخام، وكان من أهم العوامل التي ساعدت في تطويرها الاقتصادي المشهود، المهارات التقنية والإدارية في الصناعة، حيث هيأت الجامعات ومعاهد التعليم العالي توفير التعليم والتدريب المهني والتقني المناسبين للإنجاز الاقتصادية وفق رؤية تطويرية شاملة تيسر جنباً إلى جنب مع التطورات المعاصرة (هاتر، وبرباري لينجنز، 1988). وإن انطلاقة التجربة التنموية للدول الآسيوية الكبرى كان من زاوية الاهتمام بالتعليم والتدريب (الشافعي، 2016). وتعمل اليابان بشكل مستمر على جعل التعليم والتدريب المهني والتقني يسير جنباً إلى جنب مع التطورات المتجددة في تكنولوجيا الإنتاج والأنماط الجديدة لتحسين أداء الخدمات، مما دعم جهود التنمية المستدامة وأسهم في تكوين الكادر البشري وفق آليات أدت إلى الحد من البطالة، وأثرت بشكل كبير في متغيرات التشغيل ودخل الفرد ومستوى معيشة المواطن (عبد القادر، 2016).

لقد أصبح من ضرورات العصر أن يتناسب الاهتمام بهذا النوع من التعليم مع التطورات المتسارعة في التقنية الحديثة التي دخلت على مجالات عمل الكيانات والأفراد، وبما يؤدي إلى تقليل الفجوة الخطيرة القائمة بين مخرجات التعليم واحتياجات سوق العمل من المهارات، حيث تعدّ التدريبات العملية بمثابة قنوات لتطبيق المعارف واكتساب الخبرة في العالم الحقيقي (الزهاء، 2018).

وتعنى الجودة في التعليم مهام إدارية محددة في وظائف التخطيط، التنفيذ، الفحص والتصحيح، بهدف تحقيق التحسين المستمر في جودة خدمات مؤسسة التعليم العالي، ويطلق على هذا النوع من التحسين المستمر دائرة "ديمنج" (Valle, 2018). والشكل التالي يوضح تلك الدائرة.

شكل رقم (1) دائرة ديمنج لمهام إدارة الجودة الشاملة

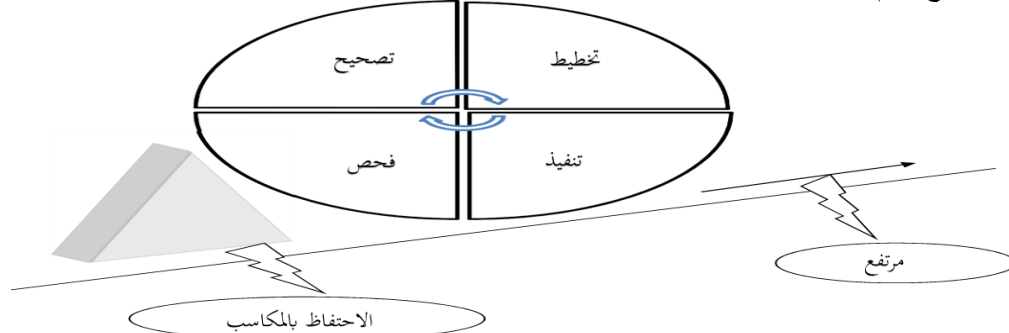

المصدر: بداري، وآخرون، 2013، بتصريف من الباحث.

ويوضح الشكل أعلاه، أن تقدم أي كيان إداري مرتبط باستمرار عمليات التحسين وبمقدار الدرجة في منحنى التحسين التي تمثلها العجلة المتصاعدة، وبدون إغفال الاحتفاظ بمكاسب التحسين (المثلث في الشكل). ومن الباحثين من أشار إلى اعتبار إدارة الجودة الشاملة في التعليم أحدث مداخل التطوير والإصلاح التربوي (أبو سمرة، وآخرون، 2008). وهناك معايير لتقييم الجودة الشاملة في التعليم ترتكز على مبادئ أساسية تؤدي إلى الاهتمام بجودة المنتج النهائي وفق سلسلة من الإجراءات التي يجب أن تتحقق في مختلف مراحل الإنتاج، والتي عادة تستند إلى مقدار الدرجة التي يتحصل عليها كيان

تعليمي في مؤشرات تقييم الجودة الشاملة وفقاً للمعايير الموصوفة لتقييم مقدار جودة مجال تعليمي ما، ومدى توفر خاصية التميز في المنتجات أو الخدمة المقدمة للعملاء (الشريف ع، 2017). ويوضح الشكل التالي هياكل التعليم الجيد الذي يتحقق فيه التميز. شكل رقم (2) هياكل التعليم الجيد الذي يحقق التميز

ثقافة الجودة

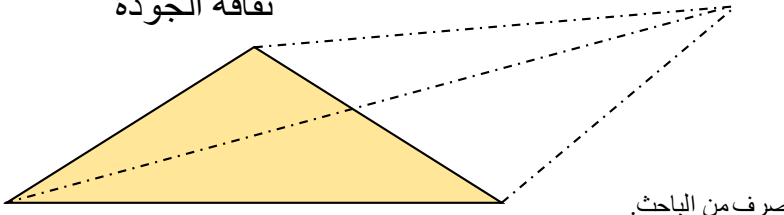

المصدر: نموذج ثاريجا (Thareja, 2017) بتصرف من الباحث.

ويبين الشكل أعلاه بأن تحقيق التميز في أي من نوع من أنواع التعليم لا يمكن أن يتحقق إلا إذا تضافرت جهود الإدارة والأشخاص العاملين في هذا الكيان لتحقيق الأهداف التي تلمح رؤية هذا الكيان الوصول إليها، ولا يمكن أن يتحقق التميز مالم تتلائم أدوار التخطيط الاستراتيجي، ونظام إدارة الجودة، والوعي بالجودة، مع استمرارية التطوير والمتابعة، حيث تركز الجودة في التعليم على الأنشطة الأساسية المرتبطة بنقل المعرفة للطلاب من خلال بيئة داعمة لانتشار ثقافة الجودة التي تعد أحد أسباب قوة التميز، وفق معايير إدارة الجودة (Thareja, 2017).

وتقاس جودة نواتج التعليم بمدى قدرة الخريجين على تلبية حاجات الأطراف المستفيدة منهم، ومستوى تحقيق رضا أصحاب العمل (نبيل، 2017). كما يمثل العائد من نواتج التعليم في مستوى الطلاقة المعرفية التي أكتسبها الطالب، حيث تُعرف الطلاقة المعرفية بأنه القدرة على فهم أنواع وطرق مختلفة من المعرفة في العلم والعمل والتنقل بينها بكل يسر (Markauskaite, 2016). ولهذا فإن النواتج التي يمكن قياسها تشمل اكتساب المعرفة والإنتاج المعرفي الذي يستدعي تحفيز الفرد على استخدام معارفه المكتسبة -ظاهرة -ضمنية، ومستوى تمتع الخريج بالكفاءة والمهارة وتنمية الذات والتمتع بثقافة التفكير المبدع (شطيبي، 2018).

وهناك العديد من الدراسات اعتمدت في قياس المخرج التعليمي على جودة أداء الكيان التعليمي، ورضا المستفيد، وجودة الخريج من الكيان التعليمي، ومن تلك الدراسات دراسة (خويكه، وآخرون، 2015؛ والظالمي، وآخرون، 2012). ومن الدراسات من قيمت مدى تحقق الجودة في المخرج التعليمي بالاستناد إلى نتائج اختبارات الطلاب الخريجين في أماكن العمل، وآراء أصحاب العمل في الخريجين، وعلى تقارير الجمعيات المهنية (احمد، 2015). والبعض الآخر من الدراسات ذهبت إلى تقييم مخرجات التعليم من خلال مهارات الأداء والاتصال والكفاءة في العمل والقدرة على الوصول إلى استخدام وإنتاج أنواع مختلفة من المعلومات والموارد لأغراض مهنية، ومنهادر اسات (Moses, 2016؛ و Florence, 2015).

والبعض الآخر من الدراسات اعتمدت في تقييم مخرجات التعليم والتدريب المهني والتقني على الربط بين المهارات العملية والنظرية، والخبرات التي اكتسبها المتدربون، وسلوكهم وطريقة تفكيرهم، ومدى قبول هذه المخرجات في سوق العمل، وجودة أداء الطلاب الذي يحقق رضا أصحاب المصلحة ومنهادر اسات كل من (Kumar, et al 2016؛ والحسيني، 2016).

وتجمع كثير من الدراسات على أن تقييم جودة مخرجات التعليم تشمل معايير يرى الباحث بأن هذه المعايير تقيم جودة المتخرج من التعليم العالي وجودة أداء الكيان التعليمي، وبعض عوامل القياس مشتركة يقيم بها الكيان التعليمي والمتخرج معاً، بالإضافة إلى تقييم رضا المستفيد، وهذه النظرة لتقييم مخرجات تعليم العالي عامة ومن الأدق والأحوط أن يقيم كل مفرد بعوامل مستقلة عن الأخرى. ويمكن أن يشملها التقييم مستوى المعرفة النوعية للخريجين، وقابلية سوق العمل للمتخرج، ومهارات الأداء وتحمل المسؤولية، والاستقلالية والإبداع، والتدريب والتطوير الذاتي.

وتعكس النزاعات على سوء الإدارة في "الدولة الهشة"، حيث أسهم غياب أو/وضعف الأداء الإداري للدولة في شلل العملية التعليمية، وتردي مستوى جودتها، نظراً لوجود علاقة إيجابية للاستقرار الوظيفي في الأداء التنظيمي بالكيانات التعليمية، وإن التعليم في حالات وجود الأمن يعزز من قيم السلام والثقة بين أطراف المجتمع، وهذه القيم تفقد في ظل النزاعات المسلحة، ويزداد التمييز (رحيمة، 2015).

ولا تنحصر التأثيرات النزاعية على الفترة المعاصرة وحسب، بل تتعدى الحاضر لتمتد تأثيراتها على رفاهية الأجيال عبر السنين، وتبرز نتائج خسران التعليم بسبب النزاع في واقع الأجيال المستقبلية المعتم والمكبد لتلك الخسائر حاضراً ومستقبلاً، وتفرض النزاعات المسلحة نتائج سلبية متنوعة في الميدان القريب والبعيد (Duarte, 2016).

وأشارت طه (2016) إلى أن أقوى الآثار السلبية للنزاع تقع على العملية التعليمية ومنشأتها، وينتج عن هذا الوضع ضعف المستوى التعليمي لدى التلاميذ، وتضعف التنشئة والتعليم للأجيال في المجتمع، وتتسبب في توقف عجلة التنمية، وهو ما يؤثر سلباً على أسس مرتكزات التنمية ومصدرها، والمتمثلة بالعنصر البشري الذي يعتبر رأس المال القيمي للمجتمع.

ومن جانب آخر فإن النزاعات المسلحة الداخلية تؤدي إلى تداعيات عدة من أبرزها الانهيار الشديد للبناء المؤسسي لأجهزة الحكومة في جميع جوانبه (الحسني، 2017). ومن أبرز جوانب الحياة المنهارة أو /المعطلة التي أفرزتها النزاعات المسلحة في اليمن هي: النظام الإداري، حيث أدي النزاع إلى إعاقة الاستقرار الإداري في كافة مؤسسات الكيان، وزاد من مستوى الفساد الإداري السابق حتى صار تألق الفساد في مؤسسات إدارة البلد بشكل عام وفي المؤسسات المعنية بالتعليم بشكل خاص (عردوم، 2017).

وقد أشار المخلافي، (2019)، إلى وجود تنظيمات غير رسمية صارت عنصراً بديناً يحول ويقف عائقاً أمام عمليات التغيير والإصلاح لأجهزة الإدارة الحكومية البنينة في ظل الوضع الحالي، بالإضافة للآثار السلبية التي أسهمت بها الانتماءات القبلية والمناطقية والحزبية على إدارة مرافق الوزارات والمصالح الحكومية. وأسهمت تداعيات النزاعات المسلحة في تردي الحالة النفسية للعاملين داخل مؤسسات العمل نتيجة لعدم الاستقرار المعيشي، مما انعكس على الأداء الإداري للفرد في مجاله الوظيفي.

وأسهمت الحالة النزاعية في اليمن إلى حد ما في ضعف البناء المؤسسي القوي والمتماسك للدولة، ناهيك عن انتشار حجم الفساد الإداري والمصرفي والتمويلي في جميع المؤسسات الاقتصادية والبيروقراطية اليمنية. كل هذا زاد من تردي الوضع الإنساني وأفقد توفر احتياجات الاستقرار الأساسية للعنصر البشري (أبوذايد، 2018).

وللتعليم في اليمن عدداً من الإستراتيجيات منها: الإستراتيجية الوطنية لتطوير التعليم الأساسي، والإستراتيجية الوطنية لتطوير التعليم الثانوي، الإستراتيجية الوطنية لتطوير الطفولة المبكرة، وإستراتيجية التدريب والتأهيل، والإستراتيجية الوطنية لمحو الأمية وتعليم الكبار، بالإضافة إلى الإستراتيجية الوطنية للتعليم العالي، والإستراتيجية الوطنية للتعليم الفني والتدريب المهني، كما يوجد خمسة مجالس عليا لإدارة التعلم. وقد وصل مستوى الإنفاق العام على التعليم اليمني 18.3% في عام 2012، والشكل رقم (2)، يبين تطور الإنفاق على التعليم خلال 10 سنوات السابقة للنزاع. وبالرغم من التقدم الذي أحرز في هذا الجانب إلى أن اليمن عجز عن تحقيق الأهداف الإنمائية للألفية 2015، ناهيك عن أن نوعية التعليم في اليمن سيئة بصفة عامة، ويتضح ذلك في نتائج التقييم الدولي للتعلم، إضافة إلى معدل البطالة العالية خاصة في جيل الشباب والفتيات (فريق البنك الدولي، 2015؛ واللجنة الوطنية للتعليم للجمع، 2014).

شكل رقم (3) الإنفاق على قطاع التعليم اليمني

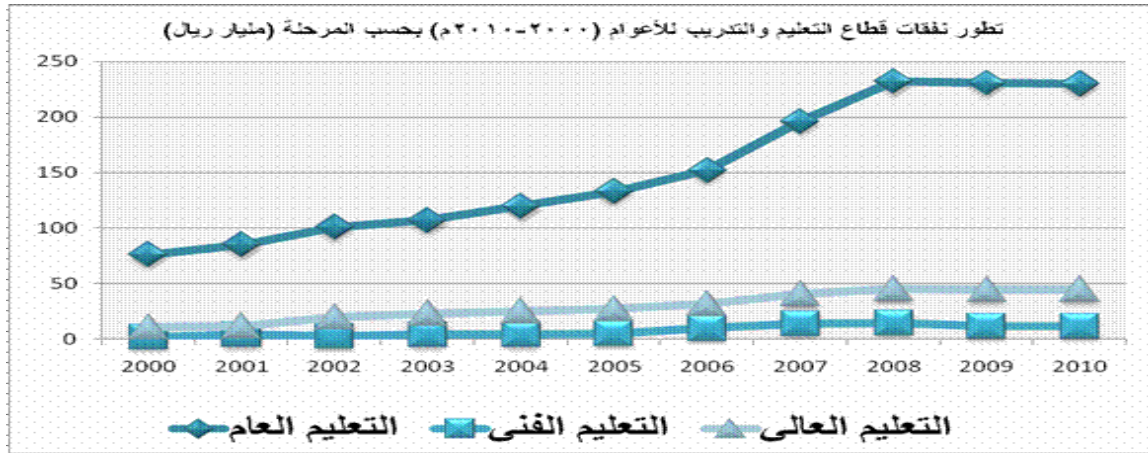

المصدر: المركز الوطني للمعلومات، 2015

ويتبين من الشكل السابق بأن مستوى الإنفاق على التعليم والتدريب المهني والتقني متدني حيث يظهر المؤشر ارتفاع طفيف في زيادة مخصصات هذا القطاع في ثلاثة أعوام ثم يتراجع ويستقر عند مستوى غير مقبول، والشكل التالي يبين سلم النظام التعليمي الحالي في اليمن.

شكل رقم (4) سلم النظام التعليمي اليمني

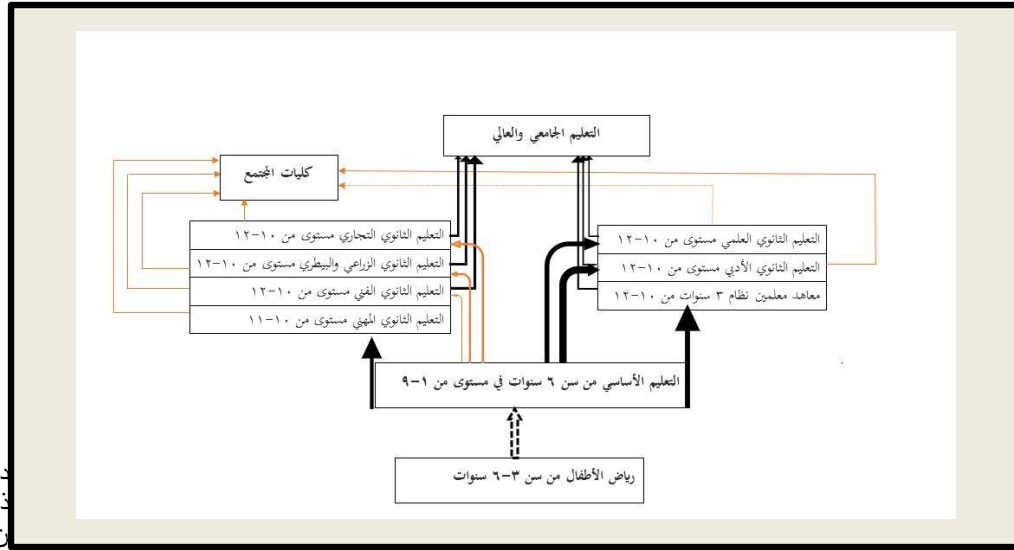

دل على ضعف ذلك أن كل هذه من التعليم لا تلي

المصدر وبالمنظرة الرؤية البشرية

الاحتياجات الفعلية للبلد، ولا سيما سوق العمل، ناهيك عما يؤدي انخفاض مستويات التحصيل العملي للطلاب؛ من فقد ثقة مؤسسات العمل بمهارات وقدرات خريجي التعليم والتدريب المهني والتقني، أضف إلى ذلك صعوبة حصول الخريجين على وظائف، وكذا ارتفاع معدلات التسرب في جميع برامج التعليم والتدريب المهني والتقني، ولا سيما بين الإناث، كما إن المناهج الدراسية بعيدة عن المهارات المطلوبة في القطاع الصناعي، وصارت التجهيزات والمعدات متهاكة وديئة ولم تعد قادرة على أن تتماشى مع متطلبات تطور سوق العمل (المشرعي، 2014).

وقد بين مؤشر المعرفة العالمي (2017) تدني مستوى التعليم والتدريب المهني والتقني في اليمن، حيث حصل هذا المؤشر على أقل من 30% من نسبة قياس هذا المحور. وبين هذا التقرير بأن حال التعليم والتدريب المهني والتقني حسب المؤشرات المرصودة غير مرضية وواقعها أليم.

2. مشكلة الدراسة

لقد أسهمت النزاعات المسلحة المتعاقبة في اليمن في تخلف مأساوي ناتج عن تفاعل ظاهره ثلاثية الأبعاد: شبح المجاعة، وتفشي الأمراض، وحرمان من التعليم. والوضع التعليمي في اليمن هو إحدى مقومات التنمية البشرية التي تضررت من جراء تداعيات النزاعات المسلحة، التي أسهمت في تعطيل الخدمات التعليمية ناهيك عن ضعف جودتها، وهذا ما بينه مركز الدراسات والإعلام التربوي (2017) حيث أشار إلى أن نسب التسرب في مختلف المنشآت التعليمية ارتفعت عما كان عليه قبل النزاع بنسبة 60%، وهناك حوالي مليوني طفل تسربوا حالياً من المدارس، ممن هم في سن التعليم، ويضاف إليه 1.6 مليون طفل خارج مؤسسات التعليم من قبل فترة النزاع، ليقتررب إجمالي الأطفال خارج التعليم من نصف عدد الأطفال الذين هم في سن المدرسة، والمقدر عددهم ب 7.3 مليون طفل، وأكثر من 3700 منشأة تعليمية مغلقة نظراً لتعرض بعضها للتدمير الكلي أو الجزئي من جراء الأعمال القتالية، واستخدم البعض منها لإيواء النازحين من مناطق القتال، فيما استخدمت مئات المنشآت التعليمية للأعمال العسكرية، وهذا ما جعل تداعيات النزاع أشد وطناً على التعليم بأنواعه المختلفة.

وأدى هذا إلى تراجع العملية التعليمية وجودة مخرجاتها كما زاد من التأثير السلبي على مستقبل الشباب، وليس وضع التعليم والتدريب المهني والتقني بأحسن حال مما ذكر آنفاً، حيث يستقطب هذا النوع من التعليم حالياً أقل من 2% من خريجي التعليم العام، والإنفاق على هذا النوع من التعليم يمثل 1.02%، من إجمالي الإنفاق الحكومي، أي ما يعادل 0.2% فقط من الناتج المحلي الإجمالي، ويضاف إلى ذلك أن الملتحقين بالتعليم الفني والمهني لا تتاح لهم فرص الالتحاق بالتعليم العالي (تقرير اللجنة الوطنية للتعليم للجميع، 2014). وبما أن الطلاب الملتحقين بهذا التعليم هم من الفئة العمرية المرغوب في استقطابهم للقتال من قبل أطراف النزاعات، فإن التداعيات حيالها كثيرة، ناهيك عن الأضرار المتعددة، ومنها تعرض أكثر من 67 منشآت التعليم والتدريب المهني والتقني الحكومية للتدمير الكلي والجزئي، وتدمير عدد 17 من المنشآت الخاصة، وعدد العاملين في التعليم والتدريب المهني والتقني 3,315 موظفاً وموظفة قبل النزاع في العام 2013/ 2014، انقطع منهم عن العمل بسبب النزاعات المسلحة ما يربو على 1928 موظفاً وموظفة يمثلوا ما نسبته 58% من مجموع الكادر البشري. وفي جانب الطلاب شهد العام الدراسي 2014/ 2015 انقطاع 9500 طالباً وطالبة عن الدراسة في

29 مؤسسة تعليمية وتدريبية، بالإضافة إلى ضعف مقدرة عدد كبير من الطلاب على مواصلة الدراسة نتيجة لنزوح عائلاتهم إلى مناطق لا يتوفر فيها هذا النوع من التعليم (الإدارة العامة للإحصاء، 2016).

وفي ظل هذا الوضع أسهمت النزاعات المسلحة في تدمير البنى التحتية للتعليم والتدريب، وانعكس ذلك بشكل كبير على المستوى التعليمي بكافة أنواعه ومستوياته، وعلى جودة خريجي التعليم والتدريب المهني والتقني بشكل خاص، حيث تعزى جودة خريجي التعليم والتدريب الفني والمهني إلى متغيرات مختلفة والتي من أهمها: اكتساب المعرفة، والتكيف مع مجتمع العمل، وتنمية الذات، واكتساب الكفاءة، ومهارات العمل ضمن فريق، والقدرة على تحمل المسؤولية وحل المشكلات المعقدة، وبالرغم من أهمية هذا إلا أن هناك قلة من الباحثين الذين سلطوا الضوء على التداعيات الإدارية التي تنتج عن النزاعات المسلحة وتؤثر في جودة مخرجات التعليم والتدريب المهني والتقني.

ومن هنا تتمحور مشكلة الدراسة حول الكشف عن العلاقة بين التداعيات الإدارية للنزاع المسلح وبين جودة خريجي التعليم والتدريب المهني والتقني، عن طريق قياس آراء الكادر البشري في كليات المجتمع الحكومية باليمن، وهذا ما دعا إلى إجراء هذه الدراسة، وقوفاً على تلك الاختلالات والآثار وتحليل أبعادها، ووضع المعالجات المناسبة لذلك من خلال ما خرجت بها هذه الدراسة. وقد أثبتت عن مشكلة الدراسة سؤال محوري هو مقدار العلاقة والتأثير بين التداعيات الإدارية للنزاع المسلح وبين جودة خريجي المجتمع الحكومية اليمنية؟

اعتمدت الدراسة على عينة احتمالية من الكادر البشري في كليات المجتمع الحكومية، وكذلك المقابلة مع عينة بؤرية من الأكاديميين والإداريين والمعلمين في إحدى هذه الكليات، وتتحدد الدراسة زمنياً: بالعام الدراسي (2019/2018). ومكانياً: بالكادر البشري من الطلاب والمعلمين والإداريين في كليات المجتمع الحكومية. وتتحدد موضوعياً: بمقدار تأثير التداعيات الإدارية للنزاعات المسلحة في جودة خريجي التعليم والتدريب المهني والتقني بالتطبيق على كليات المجتمع الحكومية اليمنية.

3. مصطلحات الدراسة

تتطرق هذه الجزئية إلى أهم المصطلحات الواردة في الدراسة وهي: -التداعيات الإدارية- النزاعات المسلحة- جودة خريجي التعليم والتدريب المهني والتقني، وعلى النحو التالي بيانه.

3.1 التأثير: هو نتاج للتفاعل بين عاملين هما: المؤثر والمتأثر، بحيث يولد رد فعل مادي أو معنوي معين نتيجة لمؤثرات جديدة لدى المتلقي، تجعله يتحرك بدافع من الحالة أو من مجموعة الأفكار والمعلومات الجديدة التي تكونت لدى المتأثر كانعكاس للمؤثر، ومن ثم تتغير سلوكيات الفرد أو مجموعة الأفراد لفترة معينة وفي اتجاه معين، والتأثير بأنه تكوين الأثر في الشيء كالجرح في الجسد بيباً ويبقى أثره (عمر، 2008).

3.2 التداعيات الإدارية: إن التداعيات في معناها اللغوي هي مصدر تداعي، ومنه أن يدعو القوم بعضهم بعضاً حتى يجتمعوا، ومنه المعنى المجازي: تداعي المبني، أي آل إلى الانهيار، وبمعنى أن أجزاءه تدعو بعضها بعضاً لتجتمع وتنتهز، وتوحي كلمة تداعيات، أن أمراً يدعو أمراً آخر، مثلما يستدعي السبب النتيجة (ابن منظور، 1994). وهذا يعني بأن التداعيات هي عواقب تستدعي عواقب أخرى، لتسهم في تعطيل أو/وانهيار مجمل مقومات حياة العنصر البشري نتيجة للأفعال الشديدة التي تجرّها على الفرد والمجتمع. فيما تعتبر الإدارة بأنها عملية تنظيم، وتنسيق للنشاطات المختلفة، وذلك من أجل تحقيق الأهداف المعينة للكيان (شوقار، 2013).

3.3 النزاعات المسلحة: هي كل إضافات أو عاقبة خلفتها المواجهة الحادة والفعل الحشن، وما تسببه حالاً ومآلاً من أذى يطال الفرد والمجتمع بطرق مباشرة وغير مباشرة، وكل عاقبة ذو صلة بمجالات الاستقرار الإداري في المجتمع. وتعرف التداعيات الإدارية للنزاعات المسلحة إجرائياً بأنها مقدار الاختلال الإداري الذي لحق بالكيان الإداري للدولة، والذي انعكس بصورة سلبية ومؤثرة على ضعف جودة الأداء الإداري لمنظومة التعليم والتدريب المهني والتقني، ويقاس ذلك بمقدار الدرجة التي حصلت عليها مفردات التداعيات الإدارية التي قيست بالفقرات من رقم 42-50.

3.4 الجودة: عملية تتكون من جهد مستمر لتحقيق تحسن معقول، ويأتي هذا الجهد من داخل النظم الذي يتطلبه (Valle, 2018). فهي ثقافة تتصف بها الكيانات المتميزة التي تسعى إلى التنافس في العمل وفق مقتضاها، وهي سلوك للإدارة المعاصرة، وتسعى الجودة في مجال التعليم إلى التحسين المستمر للمنتج التعليمي، الذي يستوعب التكنولوجيا المعاصرة ويتفاعل معها وفقاً لمواصفات محددة (الظالمي، وآخرون، 2012).

3.5 التعليم والتدريب المهني والتقني: عرفته منظمة الأمم المتحدة للتربية والعلوم والثقافة (UNESCO) بأنه "مصطلح شامل يشير إلى تلك الجوانب من عملية التعليم التي تشمل، بالإضافة إلى التعليم العام، دراسة التكنولوجيات والعلوم ذات الصلة، واكتساب المهارات العملية، والمواقف والفهم والمعرفة المتعلقة بالمهنة في مختلف قطاعات الحياة الاقتصادية والاجتماعية" (Barcucci, et, Al, 2016). وتعرف جودة خريجي التعليم والتدريب المهني والتقني إجرائياً في هذه الدراسة بأنها مقدار قياس مجموع المهارات التي يكتسبها خريج التعليم والتدريب المهني والتقني، وما يتمتع به من مهارات ذاتية وقدرات معرفية تلبي متطلبات الطالب وسوق العمل والمجتمع والجهات المنتفعة منه، وتتحدد بمقدار الدرجة التي تحصلت عليها مفردات جودة خريجي التعليم والتدريب المهني والتقني، والذي شملته المفردات من رقم 51-84، والتي تحددتها نتيجة إجابات أفراد العينة لمفردات استبانة هذه الدراسة، والمعززة بنتائج المقابلة.

4. المنهجية المتبعة في الدراسة

اعتمد في الدراسة الحالية على المنهج الوصفي التحليلي الذي يهتم بدراسة واقع الظواهر، وتحليلها وتفسيرها، من أجل الوصول إلى نتائج مفيدة وقابلة للتعميم، وفق بيانات كمية ونوعية تم تحليلها بطرق إحصائية مختلفة، حيث تم الحصول على نتائج غير منحازة يمكن تعميمها بشكل أكبر (خضر، 2013). وشمل مجتمع الدراسة هنا إجمالي الكادر البشري الملحق بكليات المجتمع الحكومية والمكون من (6473)، وهو يشمل الكادر الأكاديمي، والكادر الإداري، والطلاب في مستويات الدراسة الثلاثة. وتم تمثيل العينة للمجتمع وفقاً وحجم الكادر البشري، وحددت العينة المستهدفة في هذه الدراسة وفق معادلة روبرت ماسون 776 مستجيب كان الصالح منها للتحليل بعد معالجة البيانات 615 استبانة، تم توزيع الاستبانة بشكل مباشر عن طريق الوكلاء، وكانت بدائل الإجابات خمسة حسب نظام ليكرت (غير موافق بشدة، غير موافق، محايد، موافق، موافق بشدة). وترتيب درجات البدائل (1، 2، 3، 4، 5) على التوالي.

4.1 الإجراءات الإحصائية المتبعة في تحليل بيانات المقياس: استخدم لهذا المقياس أساليب إحصائية عدة عن طريق برنامج تحليل الحزم الإحصائية وبرنامج أموس، وبهما تم تنفيذ الطرق الإحصائية التالية:

البيانات الوصفية لعينة الدراسة: لقد صنفت الخصائص الديموغرافية لمجتمع الدراسة وفقاً لخمسة متغيرات هي (الجنس، العمر، المؤهل العلمي، العمل، المنطقة الجغرافية). حيث كان عدد المستجيبين من الذكور (352)، بنسبته 57.2%، وعدد الإناث (263) بنسبته 42.8%. وتمثل نسبة الذكور أكبر مقارنة بعدد الإناث ويعزو الباحث ذلك إلى نظرة المجتمع والثقافة السائدة فيه من حيث توظيف الإناث والتحاقهن بالتعليم والتدريب المهني والتقني. وأغلبية المستجيبين تقل أعمارهم عن (30) سنة أي ما نسبته 84.9% لعدد (522) مستجيب، ويفسر ذلك أن معظم المبحوثين من الطلاب الدارسين بكليات المجتمع بعد الثانوية العامة. بينما عدد (82) من المستجيبين بنسبة 13.3% أعمارهم تتراوح بين (31: 45) سنة، وأما من أعمارهم بين (46 إلى 55) سنة، فقد كان عددهم (10) مستجيب، ويمثل ما نسبته 1.6%، وحالة واحدة من المستوى العمري الأكبر من (55). وكان توزيع أفراد العينة حسب المؤهلات العلمية متفاوت، حيث تبين بأن (346) مستجيب من الكادر البشري بكليات المجتمع اليمنية هم من المتأهلين للدبلوم بعد الثانوية أي ما نسبته 56.3%، وبلي ذلك حملة الثانوية الذي بلغوا (137) مستجيب يمثلون نسبة 22.3%، كما إن (103) مستجيب من إجمالي أفراد العينة البالغ (615) وبنسبة 16.7% يحملون شهادات البكالوريوس، بينما الذين يحملون مؤهلات عليا (ماجستير دكتوراة) يمثلون 4.2% لعدد (26) مستجيب، وعدد (3) مستجيبين هم من الحاصلين على دبلوم قبل الثانوية.

ومثل توزيع أفراد العينة حسب الوظيفة الطلاب بنسبة 79.5% تقريباً لعدد (489) مستجيب ويمثلوا أعلى نسبة، ويعزى هذا إلى أن الطلاب هم الغالبية في الكليات وأن استجاباتهم كانت سهلة، بينما كان عدد المعلمين (60) ويمثل نسبة 9.8%، ومثل الكادر الإداري بنسبة 10.7% لعدد (66) في الكليات المبحوثة. وبالنظر إلى توزيع أفراد العينة على حسب المنطقة الجغرافية لكليات المجتمع اليمنية والتي توزعت على ثلاث مناطق، حيث تمثل كلية المجتمع سيئون محافظة حضرموت أكثر عينة الدراسة (118) مستجيب بنسبة 19.2%، يليها الكادر البشري في كلية المجتمع بالمعافر وفي شرعب محافظة تعز بنسبة 17.7% لعدد (109 و 103) مستجيب وهي من المناطق التي تتميز بكثافة سكانية، بينما اقل المستجيبين من أفراد عينة الدراسة كان في كلية المجتمع بصنعاء وبلاد الروس محافظة صنعاء لعدد (39 و 47) مستجيب بنسبة 6.3% ونسبة 7.6% على التوالي، فيما كانت عينة كلية المجتمع بمحافظة ذمار (58) مستجيب ويمثلوا نسبة 9.4%، وبلغت العينة المستجيبة من يريم محافظة إب (54) مستجيب بنسبة 8.8%.

معالجة القيم المفقودة: هناك عدد من الطرق لمعالجة البيانات المفقودة؛ منها طريقة حذف تلك البيانات أو استبدالها حسب المتوسط للإجابات، وقد أتبع الباحث في معالجته لبيانات هذه الدراسة طريقة حذف الاستبيانات التي تحتوي على أكثر من عشرة حقول لم يتم التأشير عليها وعددها 35 استبانة، كما تم حذف 59 استبانة وهي الاستبيانات التي تحوي على نسبة تطابق في الإجابات اقل من 0.05، وصار إجمالي ما تم حذفه 94 استبانة غير مستوفية شروط التحليل وفق ما أشار إليه (العناني، وآخرون، 2018).

القيم المتطرفة: إن القيم المتطرفة هس نتيجة لبعض الأخطاء مثل أخطاء إدخال البيانات، أو نتيجة بعض القيم في متغير فردي أو متغيرات فردية حيث تؤدي إلى تشويه النتائج الإجمالية (Hair et al, 2006)، وقد تم فحص البيانات المتطرفة عن طريق مقارنة نتائج Chi Square (χ^2) المتحصل عليها لكل مستجيب في كل متغير بواسطة Mahalanobis، التي ينتجها برنامج أموس، وتم مقارنة تلك النتائج مع قيمة (χ^2) الجدولية المقابلة لدرجة حرية الفقرات، وتم حذف الفقرات التي تزيد قيمتها عن القيمة الجدولية.

4.2 التحليل العاملي الاستكشافي (Exploratory Factor Analysis (EFA): إن التحليل العاملي الاستكشافي هو أسلوب إحصائي رياضي يؤدي إلى تقسيم المتغيرات إلى مجموعات يطلق على كل مجموعة عامل Factor، وهذه العوامل عادة ما تكون كاملة (غير مشاهدة)، ويجب أن يحتوي كل عامل على أكثر من فقرة على الأقل، وفي هذه الدراسة تم استخدام التحليل العاملي لتلخيص مفردات الاستبانة في عدد قليل من العوامل من أجل استخدام هذه العوامل في دراسة الفرضيات المقترحة، وتم التحليل الاستكشافي لحصر العوامل على التباينات المشتركة بين المتغيرات فقط. جدول رقم (2) نتائج التحليل العاملي الاستكشافي لمقياس النداءات الإدارية للنزاع المسلح

المتغير	التشبع	المتوسط الحسابي	الانحراف المعياري	الدلالة الإحصائية
تسهم النزاعات المسلحة في ضعف الأداء الإداري لمختلف مؤسسات الحكومة	0,837	3.27	1.595	0,000
تعيق النزاعات المسلحة المؤسسات من تطبيق القوانين والأنظمة بصورة مهنية وعادلة	0,812	3.37	1.618	0,000
في ظل النزاعات المسلحة تفقد المؤسسات قدرتها على اتخاذ قرارات إدارية سليمة	0,827	3.42	1.576	0,000
تؤثر النزاعات المسلحة في البناء المؤسسي المتين لأجهزة الحكومة	0,797	3.44	1.553	0,000
تؤدي النزاعات المسلحة إلى إعاقة الاستقرار الإداري في كافة مؤسسات الحكومة	0,826	3.44	1.574	0,000
تؤدي النزاعات المسلحة إلى ارتفاع مستوى الفساد الإداري	0,810	3.43	1.610	0,000
تؤثر النزاعات المسلحة على الحالة النفسية للعاملين داخل مؤسسات العمل	0,822	3.40	1.592	0,000
تعمق النزاعات المسلحة مستوى انخفاض الثقة بين مكونات المجتمع المختلفة	0,791	3.57	1.498	0,000
تؤدي النزاعات المسلحة إلى هجرة الكفاءات العلمية والعامة المدربة والماهرة	0,770	3.45	1.616	0,000

المصدر: من إعداد الباحث استناداً إلى مخرجات التحليل الاستكشافي بواسطة برنامج SPSS. ويشاهد في الجدول أعلاه أن النداءات الإدارية للنزاع المسلح حملت في (9) فقرات في العامل الثاني، وأكبر متوسط حسابي حصلت عليه الفقرة رقم (49) بنسبة (3.57) وانحراف معياري قدره (1.5)، وحصلت الفقرة رقم (42) على أقل متوسط حسابي، بنسبة (3.27) وانحراف معياري قدره (1.6). وكان تشييعات هذا العامل جيدة حيث كانت واقعة بين (0,837) كأعلى تشبع حصلت عليه الفقرة رقم (42)، وبين (0,770) للفقرة رقم (50). كما كانت جميع الفقرات عند مستوى معنوية أقل من 0.001؛ وتعد جميعاً ذات دلالة إحصائية.

4.3 نتائج التحليل العاملي الاستكشافي لجودة خريجي التعليم والتدريب المهني والتقني
لقد تبين من التحليل العاملي الاستكشافي لعوامل قياس جودة خريجي التعليم والتدريب المهني والتقني أن فقرات هذا المتغير حملت في أربعة عوامل يقيس العامل الأول مهارات الأداء وتحمل المسؤولية لدى الخريج، ويقاس العامل الثاني مستوى المعرفة النوعية التي يتمتع بها الخريجين، وقاس العمل الثالث التعلم الذاتي والتطوير المستمر، فيما قاس العامل الرابع الاستقلالية والإبداع لدى المتخرجين، والجدول التالي تفصل بياناتها. جدول رقم (3) نتائج التحليل العاملي الاستكشافي لمهارات الأداء وتحمل المسؤولية لدى الخريج

نص فقرة القياس	المتوسط الحسابي	الانحراف المعياري	التشبع العاملي	الدلالة الإحصائية
يكتسب الطالب القدرة على إدارة مهام العمل على المستوى الشخصي والمهني	3.32	1.284	0,739	0,000
يلتزم خريج الكلية بالقيم الأخلاقية السامية على النطاق الشخصي والاجتماعي	3.41	1.256	0,732	0,000
يتمتع الخريج بالقدرة على المشاركة مع النظراء في العمل من المتخصصين وأصحاب الكفاءات العالية	3.37	1.266	0,786	0,000
يتمتع الخريج بقدرة على تقييم وتطبيق الأدوات والاستراتيجيات البحثية المرتبطة بمجمله المعرفي والتخصصي	3.37	1.295	0,777	0,000
لدى الطالب القدرة على التقويم الذاتي وتحمل المسؤولية تجاه مجتمع وفريق العمل المنتمي له	3.42	1.291	0,766	0,000
يكتسب الخريج القدرة على تحمل مسؤولية إدارة العمل أو الإشراف على الآخرين في مجال تخصصه	3.38	1.249	0,781	0,000

0,000	0,781	1.277	3.37	يكتسب الطالب مهارات مهنية وتقنية تمكنه من المشاركة في الاداء الإداري والمهني في مختلف الظروف
0,000	0,789	1.265	3.34	لدى الطالب القدرة على تقييم وتطبيق الإجراءات الملائمة في عمليات حل المعضلات في العمل
0,000	0,701	1.332	3.36	يتزود الطالب بمهارات متقدمة ومنتطورة في تكنولوجيا الاتصالات والمعلومات تمكنه من شرح وتحليل القضايا المعقدة وغير المتوقعة
0,000	0,741	1.303	3.32	يمتلك الخريج إمكانية تحمل المسؤولية في تطوير اساليب العمل بما في ذلك المواقف غير المتوقعة
0,000	0,783	1.279	3.41	خريجو الكلية مستعدون لتحمل مسؤولية إدارة العمليات الفنية والإشرافية التي توكل اليهم في قطاعات العمل

المصدر: من إعداد الباحث استنادا إلى مخرجات التحليل العاملي الاستكشافي بواسطة برنامج SPSS. يوضح الجدول أعلى هذا الإحصاءات الوصفية (المتوسط الحسابي - الانحراف المعياري) بالإضافة إلى مقدار تشعب فقرات عامل مهارات الأداء وتحمل المسؤولية لدى خريجي التعليم والتدريب المهني والتقني تشبعت في (11) فقرة من الفقرات التي تقيس جودة خريجي التعليم والتدريب المهني والتقني والمكونة من (34) فقرة، ونجد أن أكبر متوسط حسابي حصلت عليه الفقرة رقم (74) وأقل متوسط حسابي حصلت عليه الفقرة رقم (70)، وكانت قيم المتوسط الحسابي عالية حيث وقعت بين (3.42)، وكان الانحراف المعياري واقع بين (1.332)، للفقرة رقم (78) وبين (1.249) للفقرة رقم (75). كما نجد بأن تشبعت هذا العامل كانت جيدة حيث كانت واقعة بين (0,789) كأعلى تشعب حصلت عليه الفقرة رقم (77)، وبين (0,701) للفقرة رقم (78). كما كانت جميع الفقرات عند مستوى معنوية أقل من 0.001؛ وتعد جميعاً ذات دلالة إحصائية. وفي الجدول التالي بيان لنتائج التحليل العنقلي الاستكشافي لمستوى التعلم الذاتي والتطوير المستمر لدى الخريجين.

جدول رقم (4) نتائج التحليل العاملي الاستكشافي للتعلم الذاتي والتطوير المستمر لدى الخريجين

نص فقرة القياس	المتوسط الحسابي	الانحراف المعياري	التشعب العنقلي الإحصائية	الدلالة الإحصائية
مصادر التعليم والتدريب الذاتي في الكلية تریه، وتسهم في تنمية القدرات الشخصية للطلاب	1.87	1.180	0.638	0,000
يحفز أعضاء الهيئة التدريسية الطلبة على التعليم والتدريب المهني والتقني الذاتي	2.04	1.275	0.643	0,000
تشمل مقررات الكلية مجالات محددة لتنمية التعلم الذاتي، وتطوير المهارات المهنية والتقنية للطلبة	1.90	1.161	0.719	0,000
تطور الكلية خططها للتعليم الفني والتدريب المهني الذاتي باستمرار	2.33	1.173	0.646	0,000
تتطور في الكلية قدرة الطالب على ممارسة العمل الجماعي بكفاءة عالية	2.13	1.300	0.745	0,000
يتمتع الطالب بالاستعداد لتحمل مسؤولية التعلم الذاتي والالتزام بالتطوير الشخصي والمهني	1.99	1.188	0.804	0,000
يمتلك الطالب القدرة على السعي الدؤوب لتحقيق التطور الوظيفي والتعلم المستمر	2.04	1.175	0.761	0,000

المصدر: من إعداد الباحث استنادا إلى مخرجات التحليل العاملي الاستكشافي بواسطة برنامج SPSS. يوضح الجدول أعلى هذا الإحصاءات الوصفية (المتوسط الحسابي - الانحراف المعياري) بالإضافة إلى مقدار تشعب فقرات عامل التعلم الذاتي والتطوير المستمر لدى خريجي التعليم والتدريب المهني والتقني تشبعت في (7) فقرات من فقرات مقياس المتغير التابع، ونجد أن أكبر متوسط حسابي حصلت عليه الفقرة رقم (63) بنسبة (2.33)، وأقل متوسط حسابي حصلت عليه الفقرة رقم (59)، بنسبة (1.87)، فيما وقع الانحراف المعياري بين (1.300)، للفقرة رقم (64) وبين (1.161) للفقرة رقم (61). كما نجد بأن تشبعت هذا العامل كانت جيدة حيث كانت واقعة بين (0,804) كأعلى تشعب حصلت عليه الفقرة رقم (65)، وبين (0,638) للفقرة رقم (59). كما كانت جميع الفقرات عند مستوى معنوية أقل من 0.001؛ وتعد جميعاً ذات دلالة إحصائية. وفي الجدول التالي بيان لنتائج التحليل العاملي الاستكشافي لمستوى المعرفة النوعية التي يكتسبها الخريج.

جدول رقم (5) نتائج التحليل العاملي الاستكشافي لمستوى المعرفة النوعية للخريج

نص فقرة القياس	المتوسط الحسابي	الانحراف المعياري	التشعب العنقلي	الدلالة الإحصائية
يتمتع خريجو الكلية بمهارات تقنية ومهنية تؤهلهم للعمل باتقان في ميادين العمل	1.95	1.173	0.774	0,000
يكتسب الطالب في الكلية معرفة نظرية وعملية متخصصة، وفهم لنطاق العمل او التخصص	1.93	1.213	0.819	0,000
يكتسب الطالب في الكلية معرفة كافية بالأنظمة والمعايير والقوانين المنظمة للعمل في مجال تخصصه	1.87	1.201	0.834	0,000
يتزود الطالب في الكلية بالفهم الدقيق للمعارف والمهارات المهنية المتخصصة التي يحتاجها عمله بعد التخرج	1.89	1.163	0.789	0,000
يحصل الطالب على فهم معرفي شامل، يمكنه من القدرة على تقييم الأساليب الفنية وحل المشكلات	1.92	1.138	0.754	0,000
يعرف الطالب جيدا على مصادر المعرفة الحالية والحديثة التي تمكنه من التعامل مع المستجدات التقنية	1.97	1.195	0.720	0,000
يحصل الطالب على فهم معرفي شامل من خلال البرامج/المقررات الدراسية التي ترتبط باتقان تخصصه	1.95	1.173	0.722	0,000

المصدر: من إعداد الباحث استنادا إلى مخرجات التحليل العاملي الاستكشافي بواسطة برنامج SPSS. يوضح الجدول أعلى هذا الإحصاءات الوصفية (المتوسط الحسابي - الانحراف المعياري) بالإضافة إلى مقدار تشعب فقرات عامل مستوى المعرفة النوعية لدى خريجي التعليم والتدريب المهني والتقني تشبعت في (7) فقرات من فقرات مقياس المتغير التابع، ونجد أن أكبر متوسط حسابي حصلت عليه الفقرة رقم (56) بنسبة (1.97)، وأقل متوسط حسابي حصلت عليه الفقرة رقم (53)، بنسبة (1.87)، وقيم المتوسط الحسابي هذه مقبولة، فيما وقع الانحراف

المعباري بين (1.173)، وللفقرة رقم (51) وبين (1.213) للفقرة رقم (52). كما نجد بأن تشبعات هذا العامل كانت جيدة حيث كانت واقعة بين (0,843) كأعلى تشبع حصلت عليه الفقرة رقم (53)، وبين (0,720) للفقرة رقم (52). كما كانت جميع الفقرات عند مستوى معنوية أقل من 0,001؛ وتعد جميعاً ذات دلالة إحصائية. وفي الجدول التالي بيان لنتائج التحليل العاملي الاستكشافي لمستوى الإبداع والاستقلالية التي يكتسبها خريجي التعليم والتدريب المهني والتقني.

جدول رقم (6) نتائج التحليل العاملي الاستكشافي للاستقلالية والإبداع

نص فقرة القياس	المتوسط الحسابي	الانحراف المعياري	التشبع العفلي	الدلالة الإحصائية
يتمتع الخريج بقدرة على العمل والتكيف مع الأدوار الوظيفية المساعدة باستقلالية، وبأقل توجيه	3.57	1.226	0.804	0,000
يستطيع الخريج العمل بشكل إبداعي وفعال في إدارة المواقف والأنشطة الفنية والمهنية	3.56	1.164	0.818	0,000
يمتلك الطالب المهارات الفنية الإبداعية والتحليلية الملائمة لحل المشكلات المرتبطة بمجاله المعرفي	3.53	1.197	0.750	0,000
يكتسب الطالب في الكلية القدرة على الحل الإبداعي للمشكلات، والمواقف الجديدة والغير متوقعة	3.13	1.07	0,69	0,000

المصدر: من إعداد الباحث استناداً إلى مخرجات التحليل العاملي الاستكشافي بواسطة برنامج SPSS.

يوضح الجدول أعلى هذا الإحصاءات الوصفية لعامل الاستقلالية والإبداع في عمل خريجي التعليم والتدريب المهني والتقني حيث تشبعات في هذا العمل (4) فقرات، وكان أكبر متوسط حسابي حصلت عليه الفقرة رقم (81) بنسبة (3,57)، وأقل متوسط حسابي حصلت عليه الفقرة رقم (84)، بنسبة (3,13)، فيما وقع الانحراف المعياري بين (1,226)، وللفقرة رقم (81) وبين (1,07) للفقرة رقم (84). كما نجد بأن تشبعات هذا العامل كانت جيدة حيث كانت واقعة بين (0,818) كأعلى تشبع حصلت عليه الفقرة رقم (82)، وبين (0,69) للفقرة رقم (84). وكانت جميع الفقرات عند مستوى معنوية أقل من 0,001؛ وتعد جميعاً ذات دلالة إحصائية.

ونجد فيما سبق بأن الأسئلة التي قاست جودة خريجي التعليم والتدريب المهني والتقني جيدة، حيث كشفت نتيجة اختبار (كايزر ماير أولكين واختبار بار تليت) أن الجودة الكلية لمفردات هذا الاختبار عالية، وأن العينة ملائمة للاختبار. حيث كان مقدار كيمو لجميع المتغيرات التابعة تشير إلى جودة جيدة حيث وصلت إلى 0.94 ومقدار دلالة بار تليت هي 0.000، ودرجة حرية 378، وكما يوضح النموذج في الجدول التالي.

جدول رقم (7) الجودة الكلية لمفردات المتغير التابع

مقدار جودة البيانات	مقياس الاختبار
0.94	مقياس عينات الملائمة (كيمو - KMO)
11197.019	مربع كاي التقريبي
378	اختبار بار تليت (Bartlett)
0.000	اختبار بار تليت (DF درجة الحرية) Sig. الدلالة

المصدر: من إعداد الباحث استناداً إلى مخرجات التحليل العاملي الاستكشافي بواسطة برنامج SPSS.

ويوضح جدول الجذر الكامن Eigen Value لعوامل جودة خريجي التعليم والتدريب المهني والتقني مجموع مربعات إسهامات كل المتغيرات على كل عامل من عوامل المصفوفة كلاً على حدة، ويلاحظ بأن العوامل الأولى هي التي حصلت على أكبر جذر كامن من باقي العوامل التي تليها، ويشترط لقبول العامل أن يكون جذره الكامن أكبر من واحد صحيح، وما عداه يرفض.

جدول رقم (8) الجذر الكامن لعوامل جودة خريجي التعليم والتدريب المهني والتقني

العامل	القيم الذاتية للجذر الكامن			قيم الجذر التربيعي المستخلصة			قيم الجذر التربيعي المدورة		
	المجموع	النباين%	التراكمي%	المجموع	النباين%	التراكمي%	المجموع	النباين%	التراكمي%
1	10.4	36.99	36.999	10.4	36.99	36.999	7.02	25.08	25.081
2	4.65	16.61	53.604	4.65	16.61	53.604	4.78	17.13	42.213
3	1.84	6.586	60.190	1.84	6.586	60.190	4.16	14.86	57.076
4	1.35	4.821	65.012	1.35	4.821	65.012	2.22	7.935	65.012

المصدر: من إعداد الباحث استناداً إلى مخرجات التحليل العاملي الاستكشافي بواسطة برنامج SPSS.

ونشاهد في الجدول أعلاه بأن الإجابة على فقرات الاستبانة حملت في أربعة عوامل، وهذه العوامل هي التي كانت قيم الجذر التربيعي لها أكبر من الواحد الصحيح، وكما تم الحصول على نسب تفسير التباينات من التباين الكلي لكل عامل على حدة، وتكشف الستة العوامل المبينة في الجدول ما نسبته (65,012)، وهذه النسبة جيدة. وأنه كلما زادت القيمة الذاتية للعامل كلما زاد التباين الذي يفسره هذا العامل.

4.4 التحليل العاملي التوكيدي لمقياس التدايعات الإدارية للنزاع المسلح

إن الهدف من التحليل العاملي الاستكشافي هو تحديد أبعاد العناصر التي تقيس المتغيرات، في حين يهدف التحليل العاملي التوكيدي إلى التحقق من صحة النموذج القياسي. وفي هذه الدراسة تم التحقق من صحة نتائج مؤشرات المطابقة لنموذج قياس التدايعات الإدارية للنزاع المسلح بإجراء التحليل العاملي التوكيدي لبيانات هذا المتغير، حيث تم إجراء تعديل على النموذج من خلال فحص البواقي ومؤشرات التعديل والتي يتيحها برنامج Amos، وتم الأخذ بعين الاعتبار الجانب النظري والمنطقي في التأكد من صحة التعديل، حيث يتم تحديد النموذج بشكل صحيح، وحققت أغلب البواقي الموحدة نتائج لهذا المقياس حسب ما يشترطه كتاب الإحصاء، حيث منهم من يرى ب، تكون أغلب البواقي أقل من 2 من القيم المطلقة، حتى يمكن الجزم بأن نموذج القياس محدد بشكل صحيح (Awang, et al, 2018). وتوضح نتائج التحليل العاملي التوكيدي للتدايعات الإدارية للنزاع المسلح في الشكل التالي.

شكل رقم (5) مؤشرات تطابق نموذج قياس التدايعات الإدارية للنزاعات المسلحة

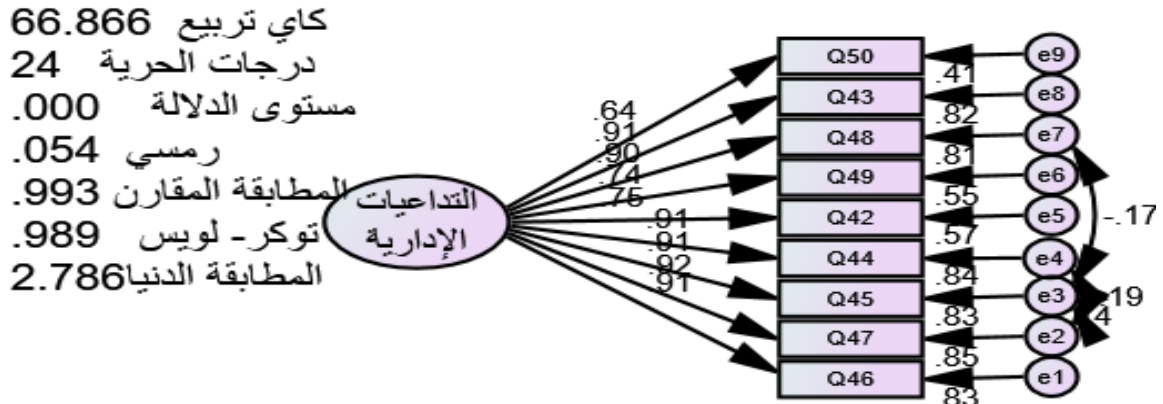

المصدر: مسار تخطيطي مستقطع من نتائج أموس محتوياً على تشبعات عوامل التدايعات الإدارية للنزاع المسلح

وتتضح مؤشرات مطابقة نموذج قياس التدايعات الإدارية للنزاعات المسلحة بأنها كانت عالية، حيث حصل مربع كاي المعياري على قيمة (66.866)، وحصل مؤشر جذر متوسط مربع الخطأ التقريبي رمسي على نسبة (0.054)، وحصل مؤشر المطابقة المقارن على نسبة (0.99)، بينما حصل مؤشر تاكر ولويس على (0.989)، وأخيراً حصل مؤشر المطابقة الدنيا على نسبة (2.786). وتدل قيم المؤشرات المذكورة أنفاً على قوة العلاقة بين عوامل هذا المقياس حيث تجاوزت قيم المحك المثالية للنموذج، مما يؤكد على أن نموذج القياس يتطابق مع النموذج النظري بشكل جيد، وبالتالي فإن النموذج مقبول للقياس.

جدول (10) أوزان الانحدار للمتغيرات المشاهدة لمقياس التدايعات الإدارية للنزاعات المسلحة

رقم الفقرة	أوزان الانحدار المعيارية				أوزان الانحدار اللا معيارية				قيمة P
	Estimate	S.E.	C.R	تربيع الارتباط (R2)	Estimate	S.E.	C.R	Loading	
Q46	1.00			0.832	3.436			0.912	0,00
Q47	1.036	0.026	39.304	0.854	3.429	0.065	52.836	0.924	0,00
Q45	0.985	0.026	37.579	0.828	3.438	0.063	54.889	0.91	0,00
Q44	1.004	0.026	38.3	0.835	3.42	0.064	53.795	0.914	0,00
Q42	0.837	0.034	24.858	0.568	3.273	0.064	50.89	0.754	0,00
Q49	0.773	0.032	24.074	0.548	3.571	0.06	59.095	0.74	0,00
Q48	1.001	0.027	36.972	0.814	3.4	0.064	52.973	0.902	0,00
Q43	1.021	0.027	37.473	0.82	3.374	0.065	51.704	0.906	0,00
Q50	0.719	0.038	18.991	0.408	3.452	0.065	52.96	0.639	0,00

المصدر: من إعداد الباحث بالاستناد إلى نتائج مخرجات القياسات المعيارية للبيانات في برنامج أموس

ونشاهد في الجدول بأن التشبع بين عامل التدايعات الإدارية للنزاع المسلح والفقرات التسع التي تمثلها كانت عالية، حيث يلزم لقبول قيم التشبع لكل فقرة ألا تقل عن 0.5 في المقاييس المطورة، وأما المقاييس المستمدة من دراسات مشابهة فيلزم أن يتجاوز تشبع الفقرات في كل عامل 0.6، ليتحقق شرط أحادية البعد (Awang, et al, 2019). ونشاهد أن نسب التشبع وقعت بين (0.639)، و(0.924)، وهذه النسب أعلى من قيم المحك. وكان ومقدار الارتباط التربيعي المتعدد لفقرات هذا العامل حيث تراوحت بين نسبة (0.408) وبين نسبة (0.854). وتراوحت قيم تي في التقديرات المعيارية بين (50.89) وبين (59.095) وهذه القيم أعلى من القيمة المعيارية للقبول.

ويطلب للتحقق من فقرات الدراسة ثلاثة أنواع من الصدق في كل نموذج قياس، ويطلق على النوع الأول الصدق التقاربي؛ الذي يتحقق في حالتين الأولى؛ أن تكون جميع الفقرات في النموذج ذات دلالة إحصائية، أي أن النسبة الفئوية P-value أقل من 0,05، وهنا نشاهد بأن جميع الفقرات دالة إحصائياً عند قيمة احتمال أقل من (0,001). والحالة الثانية عندما تكون قيمة متوسط التباين المستخرج (AVE) 0.5. وأكبر حيث تجاوزت قيمة التباين المستخلص في هذا المقياس نسبة المحك وكانت (0.723). كما يتم التأكد من الموثوقية عن طريق فحص مؤشر الموثوقية المركبة (CR Composite Reliability)، ومن خلاله نتبين الثقة والاتساق الداخلي للمتغير الكامن، ومستوى القبول المشروط لها عند 0.6 وأكبر. وقد حصل مؤشر الموثوقية المركبة لهذا المقياس على نسبة (0.959)، وهي قيمة أكبر من قيمة المحك (Awang, et al, 2016).

وأما صدق التمايز فيتحقق عندما يتم التأكد من أن نموذج قياس المتغير خالي من العناصر المتشابهة في قياس مفهوم ما، من خلال ما يعرف بمؤشرات التعديل لتحديد الفقرات المكررة، وحذف إحدى هذه الفقرات أو عمل تقييد للفقرات الواقعة في نفس العامل عن طريق تقدير المعاملات الحرة لأخطاء القياس المترابطة التي تزيد عن (15) في كل عامل حتى يتحقق الاختلاف والتمايز فيما بين العوامل. كما تم عمل تقييد لعامل القياس في الفقرة رقم (45 مع 48) ورقم (47 مع 44) ورقم (47 مع 45)؛ حتى صارت النتائج تؤكد على أن نموذج قياس التدايعات الإدارية للنزاعات المسلحة خالي من العناصر المتشابهة ويتمتع بصدق التمايز، ويمكن القول بأن نموذج القياس هنا مقبول نظراً لدلالة فقراته وتمتع بصدق المتغير والصدق التقاربي وصدق التمايز. ويعرف النوع الثالث بالصدق الكامن للمتغيرات، الذي يعتمد عليه عندما تحقق مؤشرات المطابقة للمتغير المستوى المطلوب، وهناك عدمن مؤشرات قيم المطابقة التي يجيب ان تحقق مستوى القبول والجدول التالي يبين هذه المؤشرات حدودها (باعم، 2019).

وتؤكد المؤشرات السابقة ذكرها مستوى قبول المقياس نظراً لدلالة فقراته وتمتع بصدق المتغير وبالموثوقية والصدق التقاربي وصدق التمايز. والفقرة التالية أجزت التحليل العملي التوكيدي للمتغيرات الداخلية (التابع) الذي تم قياسه عن طريق فقرات جودة خريجي التعليم والتدريب المهني والتقني.

4.5 التحليل العملي التوكيدي لمقياس جودة خريجي التعليم والتدريب المهني والتقني

لقد كشفت نتائج التحليل العملي التوكيدي لمقياس جودة خريجي التعليم والتدريب المهني والتقني عن وجود تطابق في بناء مقياس توقعات جودة خريجي التعليم والتدريب المهني والتقني، وبعد إجراء تعديل على النموذج من خلال فحص البواقي ومؤشرات التعديل والتي يتميز بها برنامج Amos، فقد تم

حذف بعض الفقرات التي لها ارتباطات متشعبة، وعمل تقييد لعدد من الفقرات الواقعة في نفس العامل، حيث كشفت نتائج تحليل هذه الخطوة بأن جميع النتائج مرضية، وأن نموذج القياس الفرضي ملائم بشكل جيد لبيانات الدراسة، ويتمتع بقيم مؤشرات عالية في المؤشرات المعيارية والاعتمادية، بالإضافة إلى أن مؤشر تطابق النموذج مع البيانات جاءت تماماً مع المعايير المحددة لتدليل على حسن المطابقة. وتم التحقق من مؤشرات حسن المطابقة بالاستناد على مؤشرين من مؤشرات كل فئة من فئات المطابقة لتقييم نموذج هذه الدراسة. ونلاحظ في الشكل أدنى هذا بأن قيم مؤشرات تطابق نموذج قياس المتغيرات الداخلية بعد التعديل بعوامله الأربعة كانت فوق مستوى القبول. شكل رقم (6) مؤشرات تطابق نموذج قياس جودة خريجي التعليم والتدريب المهني والتقني

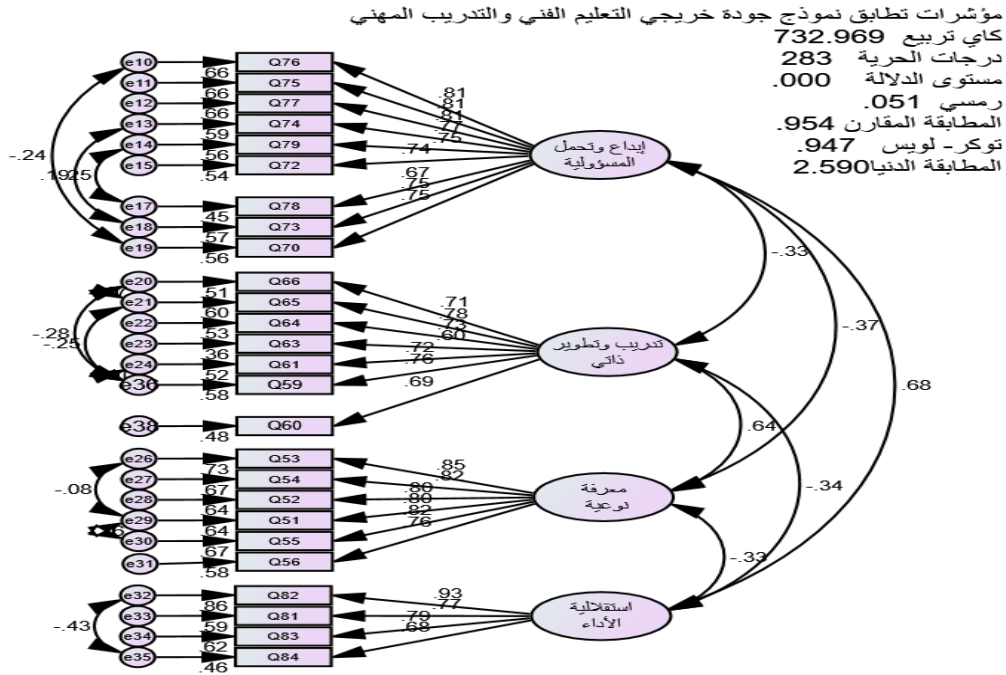

المصدر: مسار تخطيطي مستقطع من نتائج أموس محتويًا على تشيعات عوامل جودة خريجي التعليم والتدريب ويشاهد في الشكل أعلاه بأن مؤشرات مطابقة نموذج المتغير التابع لنتائج التحليل العاملي التوكيدي كانت عالية، حيث حصل مربع كاي المعياري على قيمة (732,969)، وحصل مؤشر جذر متوسط مربع الخطأ التقريبي رمسي على نسبة (0,051)، وحصل مؤشر المطابقة المقارن على نسبة (0,954)، وبينما حصل مؤشر تاكر ولويس على (0,947)، وأخيراً حصل مؤشر المطابقة الدنيا على نسبة (2,59). وتدل قيم المؤشرات المذكورة أنفاً على قوة العلاقة بين عوامل هذا المقياس حيث تجاوزت قيم المحك المثالية للنموذج، مما يؤكد على أن نموذج القياس بتطابق مع النموذج النظري بشكل جيد، وبالتالي فإن النموذج مقبول للقياس. وتفصل الجزئية التالية نتائج التحليل العاملي التوكيدي لكل متغير كامن.

التحليل العاملي التوكيدي لمقياس الأبداع وتحمل المسؤولية لدى خريجي التعليم والتدريب
تتضح نتائج التحليل العاملي التوكيدي لمقياس الأبداع وتحمل المسؤولية لدى الخريج في الجدول أدنى هذا. جدول (12) أوزان الانحدار للمتغيرات المشاهدة لمقياس جودة الأبداع وتحمل المسؤولية لدى الخريج

رقم الفقرة	أوزان الانحدار المعيارية				أوزان الانحدار اللا معيارية				قيمة P
	Estimate	S.E.	C.R	(R2)	Estimate	S.E.	C.R	Loading	
Q76	0.663	0.052	12.72	0.663	3.372	0.052	65.476	0.814	0,00
Q75	0.657	0.05	13.14	0.657	3.382	0.05	67.175	0.811	0,00
Q77	0.661	0.051	13.02	0.661	3.341	0.051	65.515	0.813	0,00
Q74	0.586	0.052	11.25	0.586	3.421	0.052	65.699	0.766	0,00
Q79	0.559	0.053	10.55	0.559	3.317	0.053	63.11	0.748	0,00
Q72	0.541	0.051	10.82	0.541	3.372	0.051	66.072	0.735	0,00
Q78	0.454	0.054	8.41	0.454	3.361	0.054	62.561	0.674	0,00
Q73	0.566	0.052	10.90	0.566	3.369	0.052	64.533	0.752	0,00
Q70	0.564	0.052	10.84	0.564	3.32	0.052	64.141	0.751	0,00

المصدر: من إعداد الباحث بالاستناد إلى نتائج مخرجات القياسات المعيارية للبيانات في برنامج أموس

ونشاهد في الجدول السابق بأن التشيع بين عامل الأبداع وتحمل المسؤولية والفقرات التسع التي تقيس هذا العامل كانت جيدة، حيث وقعت بين نسبة (0.674) كداني تشيع حصلت عليه الفقرة رقم Q78، وبين نسبة (0.814) حصلت عليه الفقرة رقم Q76 كأعلى تشيع. ويتراوح الارتباط المتعدد التربيعي لهذا المقياس بين نسبة (0.454) ونسبة (0.663). وجميع الفقرات ذات دلالة إحصائية، وقيمة تي المعيارية تراوحت بين (67.175) وبين (62.561). وبهذا يتمتع النموذج بصدق المتغير حيث استوفت جميع المؤشرات مستوى القبول. وبالنظر إلى مصفوفة صحة التمايز بين المتغيرات المبيّن لاحقاً؛ نجد بأن مؤشر الموثوقية المركبة حصل على نسبة (0.926)، وكذلك التباين المستخلص حصل على نسبة (0.583). كما تم حذف بعض الفقرات وكذا عمل تقييد للمعاملات الحرة لأخطاء القياس المترابطة للفقرات رقم (76 مع 70) ورقم (73 مع 74)، ورقم (79 مع 78)، واعتبرت أخطاء القياس المترابطة هنا وسيطات حرة، وبهذا صارت نتائج قياس جودة الأبداع وتحمل المسؤولية لدى الخريجين مقبولة نظراً لدلالة فقراته وتمتعته بصدق المتغير وبالموثوقية والصدق التقاربي وصدق التمايز.

4.6 التحليل العملي التوكيدي لمقياس التدريب والتطوير الذاتي والمستمر لخريجي التعليم الفني والتدريب
وفي الجدول أدنى هذا بيان لنتائج التحليل العملي التوكيدي لمقياس التدريب والتطوير الذاتي والمستمر للخريجين.
جدول (13) أوزان الانحدار للمتغيرات المشاهدة لمقياس جودة لتدريب والتطوير الذاتي والمستمر

رقم الفقرة	أوزان الانحدار المعيارية			أوزان الانحدار المعيارية			Loading	تثبع الفقرة	P
	C.R	S.E.	Estimate	C.R	S.E.	Estimate			
	تي الإحصائية	أخطأ القياس	مقدار التباين	تي	أخطأ القياس	مقدار التباين	تربيع الارتباط		مستوى الدلالة
Q66	43.135	0.047	2.044			1	0.511	0.715	0,00
Q65	41.437	0.048	1.985	19.3	0.057	1.097	0.601	0.775	0,00
Q64	40.547	0.052	2.125	16.364	0.069	1.128	0.532	0.729	0,00
Q63	49.31	0.047	2.332	13.726	0.061	0.839	0.361	0.601	0,00
Q61	39.335	0.048	1.872	15.959	0.063	1.009	0.516	0.719	0,00
Q59	39.717	0.051	2.041	15.009	0.077	1.154	0.579	0.761	0,00
Q60	40.618	0.047	1.901	15.592	0.061	0.954	0.477	0.691	0,00

المصدر: من إعداد الباحث بالاستناد إلى نتائج مخرجات القياسات المعيارية للبيانات في برنامج أموس

ويشاهد في الجدول السابق بأن التشبع بين عامل التدريب والتطوير الذاتي والمستمر والفرقات السبع التي تقيسه كانت جيدة، حيث وقعت بين نسبة (0.601) كأدى تشبع للفقرة رقم Q63، وبين نسبة (0.775) كأعلى تشبع حصلت عليه الفقرة رقم Q65. وتراوح الارتباط المتعدد التريبيعي للعامل بين نسبة (0.361) ونسبة (0.601). وجميع الفقرات ذات دلالة إحصائية، وقيمة تي المعيارية تراوحت بين (49.31) وبين (39.335). وعند النظر إلى مصفوفة صحة التمايز بين المتغيرات المبين لاحقاً نجد بأن مؤشر الموثوقية المركبة حصل على نسبة (0.879)، وكذلك التباين المستخلص حصل على نسبة (0.511). كما تم عمل تقييد للمعاملات الحرة لأخطاء القياس المترابطة للفرقات رقم (66مع 59) ورقم (59 مع 61)، واعتبرت أخطاء القياس المترابطة هنا وسيطات حرة. وبهذا صار عامل قياس التدريب والتطوير الذاتي والمستمر لدى الخريجين مقبول نظراً لدلالة فقراته وتمتع بصديق المتغير وبالموثوقية والصدق التقاربي وصدق التمايز.

4.7 نتائج التحليل العملي التوكيدي لمقياس المستوى المعرفي والنوعي لخريجي التعليم والتدريب
إن الجدول أدنى هذا يبين لنتائج التحليل العملي التوكيدي لمقياس المستوى المعرفي والنوعي للخريجين.
جدول (14) أوزان الانحدار للمتغيرات المشاهدة لمقياس جودة المستوى المعرفي والنوعي للخريج

رقم الفقرة	أوزان الانحدار المعيارية			أوزان الانحدار المعيارية			Loading	تثبع الفقرة	P
	C.R	S.E.	Estimate	C.R	S.E.	Estimate			
	تي الإحصائية	أخطأ القياس	مقدار التباين	تي	أخطأ القياس	مقدار التباين	تربيع الارتباط		مستوى الدلالة
Q53	39.387	0.049	1.927			1	0.725	0.852	0,00
Q54	38.718	0.048	1.875	24.806	0.038	0.952	0.671	0.819	0,00
Q52	41.139	0.047	1.946	23.985	0.038	0.91	0.642	0.801	0,00
Q51	38.045	0.053	2.013	23.076	0.044	1.019	0.644	0.802	0,00
Q55	40.231	0.047	1.886	24.502	0.038	0.92	0.668	0.817	0,00
Q56	41.912	0.046	1.924	22.308	0.038	0.841	0.583	0.764	0,00

المصدر: من إعداد الباحث بالاستناد إلى نتائج مخرجات القياسات المعيارية للبيانات في برنامج أموس
ونشاهد في الجدول أعلى هذا بأن التشبع بين عامل المستوى المعرفي والنوعي والفقرات الست التي تقيس هذا العامل كانت جيدة، حيث وقعت بين نسبة (0.764) كأدى تشبع للفقرة رقم Q56، وبين نسبة (0.852) كأعلى تشبع حصلت عليه الفقرة رقم Q53. وتراوح الارتباط المتعدد التريبيعي للعامل بين نسبة (0.583) وبين (0.725). وجميع الفقرات ذات دلالة إحصائية، وقيمة تي المعيارية تراوحت بين (41.912) وبين (38.045). وبهذا يتمتع النموذج بصدق المتغير نظر أن المؤشرات السابقة استوفت مستوى القبول. كما يتبين من جدول مصفوفة صحة التمايز بين المتغيرات المبين لاحقاً بأن مؤشر الموثوقية المركبة حصل على نسبة (0.919)، وكذلك التباين المستخلص حصل على نسبة (0.656)، بالإضافة إلى عمل تقييد للفقرة رقم (53مع 51) والفقرة رقم (51 مع 55) واعتبرت أخطاء القياس المترابطة هنا وسيطات حرة. وبهذا صار عامل قياس جودة المستوى المعرفي والنوعي للخريج مقبول نظراً لدلالة فقراته وتمتع بصديق المتغير وبالموثوقية والصدق التقاربي وصدق التمايز.

4.8 التحليل العملي التوكيدي لمقياس الاستقلالية في مهارات الأداء لخريجي التعليم الفني والتدريب
والجدول التالي أوضح نتائج التحليل العملي التوكيدي لمقياس الاستقلالية في مهارات أداء الخريجين.
جدول (15) أوزان الانحدار للمتغيرات المشاهدة لمقياس جودة الاستقلالية في مهارات الأداء

رقم الفقرة	أوزان الانحدار المعيارية			أوزان الانحدار المعيارية			Loading	تثبع الفقرة	P
	C.R	S.E.	Estimate	C.R	S.E.	Estimate			
	تي الإحصائية	أخطأ القياس	مقدار التباين	تي	أخطأ القياس	مقدار التباين	تربيع الارتباط		مستوى الدلالة
Q82	75.968	0.047	3.564			1	0.86	0.927	0,00
Q81	72.198	0.049	3.569	23.029	0.038	0.87	0.586	0.766	0,00
Q83	73.086	0.048	3.527	24.016	0.036	0.874	0.62	0.788	0,00
Q84	66.285	0.052	3.463	16.811	0.048	0.812	0.457	0.676	0,00

المصدر: من إعداد الباحث بالاستناد إلى نتائج مخرجات القياسات المعيارية للبيانات في برنامج أموس
وبمشاهدة الجدول أعلى هذا نجد بأن التشبع بين عامل الاستقلالية في مهارات الأداء والفقرات الأربع التي تقيس هذا العامل كانت جيدة، حيث وقعت بين نسبة (0.676) كأدى تشبع حصلت عليه الفقرة رقم Q84، وبين نسبة (0.927) كأعلى تشبع للفقرة رقم Q82. ويتراوح الارتباط المتعدد التريبيعي للعامل بين نسبة (0.457) ونسبة (0.86). وجميع الفقرات ذات دلالة إحصائية، وقيمة تي المعيارية تراوحت بين (75.968) وبين (66.285). وبهذا يتمتع النموذج بصدق المتغير حيث استوفت جميع مؤشرات أحادية البعد مستوى القبول. وبمراجعة مصفوفة صحة التمايز بين متغيرات نموذج القياس المبينة في الجدول أدناه نجد بأن مؤشر الموثوقية المركبة حصل على نسبة (0.871)، وكذلك التباين المستخلص حصل على نسبة (0.631)، وتم عمل

تقييد للفترة رقم (81 مع 84) واعتبر أخطاء القياس المترابط هنا وسيط حر. مما يؤكد على أن نموذج قياس جودة الاستقلالية في مهارات الأداء للخريج تمتع بمستوى القبول نظر الدلالة فقراته وتمتعه بصدق المتغير وبالوثوقية والصدق التقاربي وصدق التمايز.

5 مؤش صحة التمايز للعوامل المكونة لمقياس جودة خريجي التعليم والتدريب المهني والتقني

إن صحة التمايز للعوامل المكونة لمقياس جودة خريجي التعليم والتدريب المهني والتقني تتضح من خلال مراجعة علاقات الارتباط بين كل عاملين من العوامل ونسب التباين المشترك التي تعد دليلاً لفحص جودة مطابقة النموذج البنائي، نظراً لأن التباين المشترك محك رئيسي عند مقارنته بمتوسط التباين المستخلص، وبه يتم التأكد من صدق التمايز. والجدول التالي يبين تفاصيل التقديرات المعيارية للارتباط بين كل عاملين في نموذج القياس.

جدول (16) التقديرات المعيارية لارتباط العوامل الكامنة لمقياس جودة خريجي التعليم والتدريب المهني والتقني

R	P	C.R.	S.E.	Estimate	العامل الكامن	العامل الكامن
مقدار الارتباط	مستوى الدلالة	قيمة تي	خطأ القياس	تقديرات غير مقننة		
-0.341	0,00	7.022-	0.044	0.309-	تدريب وتطوير ذاتي	استقلالية الأداء
-0.335	0,00	7.098-	0.051	0.365-	معرفة نوعية	
-0.374	0,00	12.245	0.062	0.762	إبداع وتحمل المسؤولية	
-0.328	0,00	6.806-	0.043	0.292-	تدريب وتطوير ذاتي	إبداع وتحمل المسؤولية
0.68	0,00	7.796-	0.051	0.401-	معرفة نوعية	
0.642	0,00	10.754	0.052	0.557	معرفة نوعية	تدريب وتطوير ذاتي

المصدر: من إعداد الباحث بالاستناد إلى نتائج مخرجات بيانات المقياس بواسطة برنامج أموس

وفي الجدول أعلاه نجد أن نسب الارتباط بين العوامل داخل النموذج تراوحت بين (0.642) كأعلى نسبة ارتباط وهي بين عامل التدريب والتطوير الذاتي وبين المعرفة النوعية، بينما أقل نسبة ارتباط تحققت بين استقلالية الأداء وبين الإبداع وتحمل المسؤولية حيث كانت بنسبة (-0.374)، وهذه القيم تدل على أن العوامل اتصفت بالتمايز، حيث ابتعدت جميع العوامل في ارتباطاتها عن الانصهار التام فيما بينها والتي هي عند مستوى (0.85)، كما إن جميع العوامل ذات دلالة إحصائية أقل من (0.05). فيما تراوحت قيمة تي الإحصائية ما بين (12.245) وبين (-6.806). ويبين الجدول التالي قيم الموثوقية المركبة والتباين المستخلص والمشارك بين العوامل الكامنة التي تم بها قياس جودة خريجي التعليم والتدريب المهني والتقني.

جدول رقم (17) مصفوفة صحة التمايز بين المتغيرات لنموذج قياس جودة خريجي التعليم والتدريب

independence	Qualit know	develo pment	Creativ ity	AV E	C R	العامل الكامن
استقلالية الأداء	معرفة نوعية	تدريب وتطوير ذاتي	إبداع وتحمل المسؤولية	تباين مستخلص	موثوقية مركبة	
			0.764	0.583	0.926	إبداع وتحمل المسؤولية
		0.715	0.341-	0.511	0.879	تدريب وتطوير ذاتي
	0.81	0.328	0.335-	0.656	0.919	معرفة نوعية
0.794	0.642	0.68	0.374	0.631	0.871	استقلالية الأداء

المصدر: من إعداد الباحث بالاستناد إلى نتائج مخرجات بيانات المقياس بواسطة برنامج أموس

ونشاهد في الجدول أعلاه قيم الموثوقية المركبة والتباين المستخلص والمشارك لهذا المقياس، حيث حصل مؤشر الموثوقية المركبة أو الاتساق الداخلي للمتغير الكامن على قيم عالية تراوحت بين (0.926) كأعلى قيمة محققة في الإبداع وتحمل المسؤولية وبين (0.871)، كأقل قيمة تحققت في استقلالية الأداء، كما وقعت قيم التباين المستخلص بين نسبة (0.656) كأعلى قيمة حصل عليها عامل مستوى المعرفة النوعية وبين نسبة (0.511) كأقل قيمة حققها عامل التدريب والتطوير الذاتي. وهذه القيم التي حققها المقياس بعوامله الكامنة الأربعة كانت أعلى من قيم المحك المحددة لهذين لمؤشرين والتي سبق الإشارة إليها. كما نشاهد في الجدول بأن قيم الجذر التربيعي للتباين المستخلص والتي هي باللون الغامق أعلى من باقي القيم الموجودة في صفها وعمودها. وهذا يدل على أن جميع المتغيرات الكامنة الأربعة لمقياس جودة خريجي التعليم والتدريب المهني والتقني استوفت شروط صحة التمايز.

6 نتائج تحليل نمذجة المعادلة البنائية لفرضيات الدراسة

بعد أن تم مقارنة التحليل العاملي التوكيدي للمتغير المستقل والمتغير التابع كل على حدة كما تبين آنفاً، تم هنا إجراء التحليل المجمل للنموذج، ويتضح بأن المتغيرات الكلية المدجة سوف تزيد من درجة الحرية للنموذج. مما يستبعد وجود مشكلة في تعريف النموذج، والشكل التالي يجمع جميع المتغيرات بعد تعديل النموذج.

شكل رقم (7) تحليل نمذجة المعادلة البنائية لفرضية الدراسة

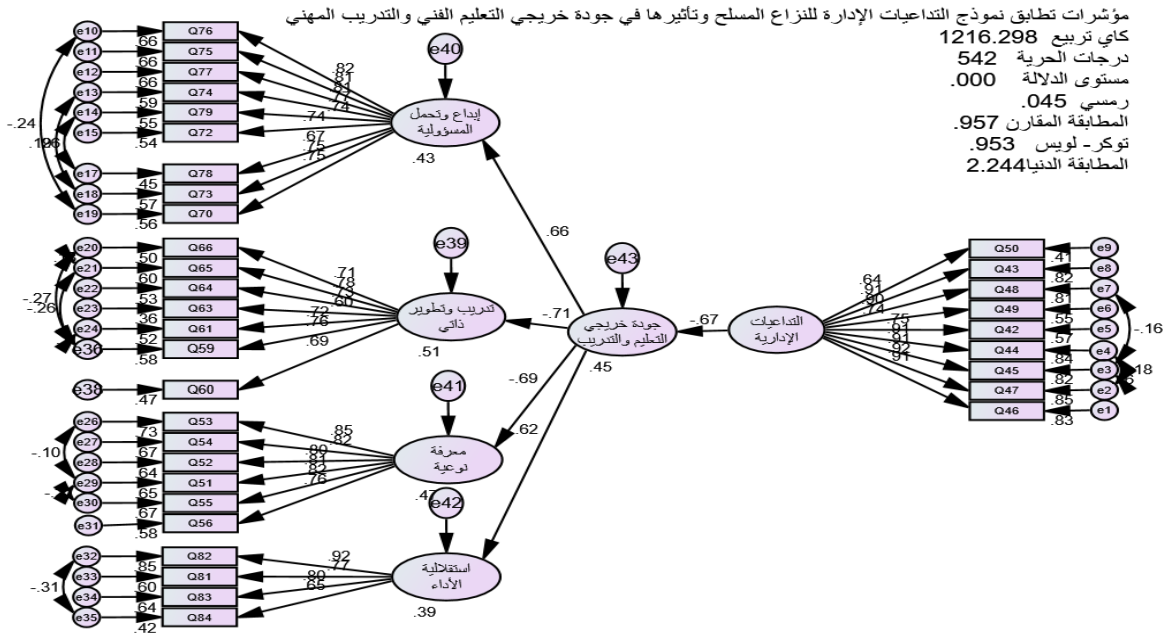

المصدر: مسار تخطيطي مستقطع من نتائج أموس محتويًا على التقديرات المعيارية لكافة عوامل متغيرات الدراسة ونشاهد في الشكل السابق بأن مؤشرات مطابقة نموذج قياس متغيرات الدراسة الكلية كانت عالية، حيث حصل مربع كاي المعياري على قيمة (1216,298)، وحصل مؤشر جذر متوسط مربع الخطأ التقريبي رمسي على نسبة (0,045)، وحصل مؤشر المطابقة المقارن على نسبة (0,957)، بينما وحصل مؤشر تاكر ولويس على (0,953)، فيما حصل مؤشر المطابقة الدنيا على نسبة (2,244). وتدلل قيم المؤشرات المذكورة أنفاً على قوة العلاقة بين عوامل هذا المقياس حيث تجاوزت قيم المحك المثالية للنموذج، مما يؤكد على أن النموذج مقبول للقياس. كما نشاهد في الرسم التخطيطي أعلاه مسار فرضيات الدراسة الرئيسية، والتي بها تم التحقق من وجود تأثيرات مباشرة للتداعيات الإدارية للنزاع المسلح على جودة خريجي التعليم والتدريب المهني والتقني بولايات المجتمع الحكومية اليمنية. ويظهر الجدول التالي مدى وجود دلالة إحصائية ومقدار التأثير لفرضيات هذه الدراسة المبينة في الشكل السابق.

جدول رقم (18) نتائج تحليل علاقة التأثير بين فرضية الدراسة

الح	P	مستوى الدلالة	ممة تي في	خطا في اس	مقدار التباين	مقدار التأثير المباشر (بيتا)	مسار التأثير	
							جود	دلة الخريجين
مقبولة بتأثير سلبي	0,00	11.802	0.0	27	0.32	0.672	جود	<

المصدر: من إعداد الباحث بالاستناد إلى نتائج مخرجات تحليل نمذجة المعادلات البنائية لنموذج الدراسة ومن الجدول أعلاه يتبين بأن فرضية الدراسة مقبولة وأنها ذات دلالة إحصائية، كما أن تأثيرها سلبي أي أن العلاقة عكسية، ويعزى هذا إلى العلاقة العكسية التي تسهم بها التداعيات الإدارية للنزاع وتأثير في جودة خريجي التعليم والتدريب المهني والتقني. ويعتبر معامل التحديد الذي يرمز له (R2) أهم مؤشر لنموذج الانحدار؛ فهو مقياساً لجودة توفيق النموذج، ونشاهد في الشكل السابق بأن معامل التحديد حصل على ما مقداره (0,45) وهذا معناه أن إسهام المتغيرات الخارجية لتداعيات النزاعات المسلحة تسهم في تقدير جودة خريج التعليم والتدريب المهني والتقني كمتغير داخلي بتفسير (45%) من التباينات الكلية التي تحدث في قيم هذا المتغير، وهذه العلاقة مقبولة، وأن الانحراف في جودة خريج التعليم والتدريب المهني والتقني (55%)؛ يرجع هذا الانحراف إلى عوامل أخرى منها الخطأ العشوائي وأخطأ القياس.

7 أدلة صدق التمايز بين جميع العوامل المكونة لمقياس نموذج الدراسة

يوضح الشكل التالي المسارات المختلفة الدالة على مؤشرات تطابق النموذج وقيم الموثوقية المركبة والتباين المستخلص والمشارك بين جميع العوامل المكونة لمقياس نموذج الدراسة.

شكل رقم (8) تحليل نمذجة المعادلة البنائية لفرضية الدراسة نتائج تحليل نمذجة المعادلة البنائية لمسار صدق التمايز بين جميع عوامل مقياس نموذج الدراسة.

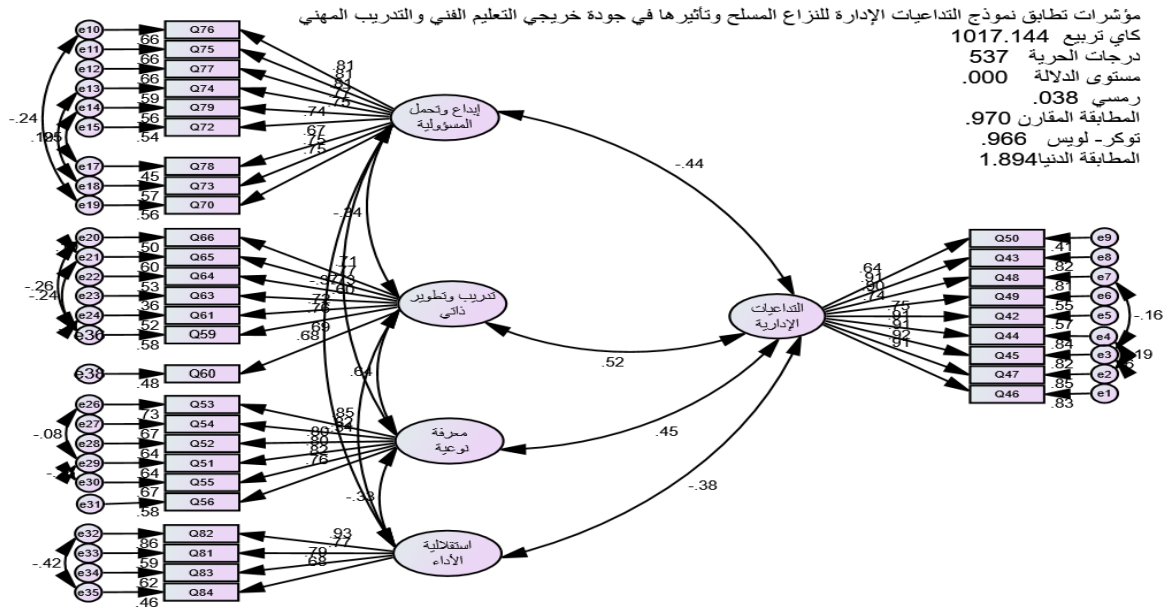

المصدر: مسار تخطيطي مستقطع من نتائج أموس محتويًا على تقديرات التباين بين متغيرات الدراسة جدول رقم (19) مصفوفة صحة التمايز بين متغيرات النموذج الكلي للدراسة

التداعي ات إدارية	استقلال ية الأداء	معرفة نوعية	تدريب وتطوير ذاتي	إبداع وتحمل المسؤولية	تباين مستخلص	مؤثوق ية مركبة	العامل الكامن
				0.76	0.58	0.926	إبداع وتحمل المسؤولية
			0.71	-	0.51	0.879	تدريب وتطوير ذاتي
		0.81	0.64	0.336	0.65	0.919	مستوى معرفة نوعي
	0.794	0.32	0.34	0.374	0.63	0.871	استقلال ية الأداء
0.850	0.381-	0.45	0.52	0.43	0.72	0.959	التداعي ات الإدارية

المصدر: من إعداد الباحث بالاستناد إلى نتائج مخرجات بيانات المقياس بواسطة برنامج أموس ونشاهد في الجدول أعلاه بأن قيم الموثوقية المركبة أعلى من قيم المحك المعياري حيث كانت بين (0.959) كأعلى نسبة حققها عامل التداعيات الإدارية للنزاع، وبين (0.871) كأدنى قيمة حصل عليها عامل استقلالية أداء المتخرج، كما إن قيم مؤشر التباين المستخلص وقعت بين (0.723) كأعلى قيمة في عامل التداعيات الإدارية للنزاع، وبين (0.51) كأدنى قيمة حصل عليها عامل التدريب والتطوير الذاتي. وتفاوتت قيم التباين المشترك بين العوامل داخل النموذج كما فصلها الجدول السابق، ونشاهد بأن القيم القطرية التي بالخط الغامق والتي هي الجذر التربيعي لمتوسط التباين المستخلص لكل متغير كانت أعلى من باقي القيم الموجودة في صفها وعمودها، وتشير هذه القيم إلى مقدار العلاقة بين المتغيرات المعنية أو ما يعرف بالتباين المشترك، وفي هذا فإن الأبعاد اتصفت بالتمايز (Discriminant Validity) حيث ابتعدت جميع الارتباطات عن الانصهار التام فيما بينها.

وتشير نتائج تحليل محتوى مقابلات المجموعات البورية إلى أن الاعتماد الكامل على النظام المركزي للدولة في التعليم والتدريب المهني والتقني شكل صعوبة وأخل بالعملية التعليمية، نظرا لحالة الضعف والاختلال الإداري البين في إدارة المؤسسات المعنية بالتعليم، وهو ما يحتم تعزيز المشاركة المجتمعية في مناطق الكليات ومشاركة رجال الأعمال وأصحاب المصلحة من المستفيدين من مخرجات التعليم والتدريب المهني والتقني، من خلال المشاركة الفعالة في تسيير وتسيير كافة سياسات وبرامج التعليم والتدريب في الكليات حتى يرتقوا جميعاً بالتعليم داخل الكليات، وبهذا يمكن القول بأننا ضمنا جودة التعليم والتدريب المهني والتقني في الكليات.

ويكاد يجمع أفراد عينة المقابلة على أن الإدارة في ظل هذه الأوضاع؛ تفقد جميعا إلى الاستقرار، وأن مركزية الإدارة وشل صلاحيات المستويات المتوسطة والأدنى في سلم إدارة التعليم زاد من تراجع جودة التعليم. وأشاروا إلى أن الكثير من الخريجين لا يحصلون على عمل بعد التخرج، والقليل منهم أتجه إلى تنفيذ مشاريع صغيرة خاص به في بعض التخصصات، ومنها على سبيل المثال؛ معامل تطوير صناعة أو إصلاح وسائل التبريد والتكييف أو ورش إصلاح السيارات، وهذا يحقق أحد أهداف كليات المجتمع، والمتمثل في ردف سوق العمل بكوادر مهنية وتقنية متميزة، وإرشاد الطالب إلى سلوك الطريق التي توصله إلى تحقيق النجاح والتميز في المجال المهني والتقني.

كما بين أغلب أفراد العينة البورية الأولى والثانية بوجود قسم في الكلية يسمى قسم التعليم المستمر، ولاكن الإقبال عليه ضعيف وقليل جدا من يعود إليه من المتخرجين، وحتى الذي يحضر إليه من العاملين في سوق العمل يكون حضوره على أساس المعرفة الشخصية بالمعلم المتمكن في تخصص ما، ولا يوجد برنامج لمتابعة حضور المتدربين من أماكن ومرافق العمل المختلفة، وقد يرجع ضعف التدريب والتطوير الذاتي والمستمر إلى الأوضاع الاجتماعية والسياسية السائدة والمؤثرة بشكل كبير. وأشاروا إلى مسالة موصلة التعليم وحصول خريجي كليات المجتمع على البكالوريوس تواجه عائق من قبل الوزارة برفض فتح بكالوريوس تطبيقي في كليات المجتمع، ولا توافق على ذلك وزارة التعليم العالي، ويرجع هذا إلى ضعف أفق الرؤية الرصينة لدى من يبدؤهم قرار إدارة العملية التعليمية، حيث وأن هذه أحد أبرز عقبات الاختلال الإداري وتناقض أهداف مؤسسات التعليم، التي تضعها الإدارة دون أن تحسب لعواقبها، فليس معيبا على الفرد أن يحصل على البكالوريوس تقني أو مهني، وماجستير تقني أو مهني، ودكتوراه تقنية أو مهنية.

ومما سبق يتبين بأن ضعف جودة خريجي كليات المجتمع ترجع إلى عدد من التحديات والصعوبات الحقيقية التي تواجه عملية ديمومة التعليم والتدريب المهني والتقني، وبالإضافة إلى ضعف الجودة في كل من المدخلات، والأداء، والموارد، ناهيك عن المعوقات الإدارية، وتقدير الإدارة العليا والمجالس المعنية بالتعليم والتدريب المهني والتقني لمدى أهمية هذا النوع من التعليم، وترجع أيضاً إلى العلاقة بين كل من التخطيط الاستراتيجي وجودة الأداء

الإداري للإدارات العليا المعنية بهذا التعليم، لأن هذه العلاقة مرتبطة بتأثيرها بقوة في الأداء التعليمي وفي جودة التعليم ومخرجاته، وأن المعوقات التنظيمية والموارد المتاحة لها علاقة بجودة التعليم وهذا ما توصلت إليه دراسات كل من (بالحمرة 2016؛ والدجني، 2011). وخلاصة القول بأن التعليم اليمني من ناحية الجودة في غيبوبة، وزاد من تلك الغيبوبة انعكاسات النزاعات المسلحة المتمثلة في: اندعام الأمن، وتدهور الوضع المعيشي، والاختلال الإداري واعتلال الإنفاق الحكومي، وتدهور البنى التحتية، والنزوح والتشرد، التي تعد ذات صلة وثيقة ومباشرة بالنزاعات المسلحة، وأن انعكاس تأثيرها على جودة العملية التعليمية برمتها أمر لا مفر منه (رحيمة، 2015).

8 الخاتمة:

لقد ارتكزت إجراءات هذه الدراسة على تثليث نتائجها كدابير لمعالجة أوجه القصور، وتجنباً للتحيز، بغية الوصول إلى نتائج شبه متكاملة تقوي الفرضيات النظرية التي ارتكز تصميم هذه الدراسة عليها. حيث صاحب نتائج البيانات التي تم الحصول عليها من المسح الميداني؛ مراجعة الأدب النظري في هذا المجال المواكب لأدبيات البحث العلمي، واستخدمت المقابلات لفحص العوامل التي تم البرهنة عليها من نتائج المسح الكمي، ويضاف إلى ذلك فحص العوامل التي قد يكون لها تأثير وتم تجاهله في الاستقصاء.

وحتى تتحقق مخرجات تعليمية نوعية ماهرة ومنتجة بجودة عالية، تسهم في تحسين فعالية الرأس المال البشري المنتج، وتدفع بعجلة التنمية الاقتصادية، للنهوض من بين برائن مخلفات النزاعات المسلحة الفذرة التي شلت قدرات الرأس المال البشري في اليمن، فإنه من الضرورة بمكان العمل على تحقيق الآتي:

أولاً: تركيز كافة الجهود في القطاع العام على إصلاح الاعوجاج في منظومة العمل الإداري وإزالة المعوقات التنظيمية في كافة المؤسسات المعنية بالتعليم والمعرفة، نظراً لوجود علاقة سلبية مؤثرة بين الأوضاع الإدارية وبين جودة خريجي التعليم والتدريب المهني والتقني، وهو ما يؤكد على قوة الاختلال في منظومة إدارة التعليم باليمن.

ثانياً: يجب أن تكون الخطط الاستراتيجية المتعددة للتعليم متناسقة وتتطلق من بوتقة واحدة، لتواكب التطور المعاصر وبما يؤدي إلى تحقيق الهدف من التعليم والتدريب المهني والتقني.

ثالثاً: إعادة النظر في تبعية كليات المجتمع، وإدراجها في هياكل الجامعات الواقعة في نطاقها، والاعتراف بمفردات مناهجها ومخرجاتها، نظراً لأن من أهداف التعليم العالي على مستوى العالم هو إعداد القوى البشرية لسوق العمل، كما أن الرؤية المبتغاة من التعليم العالي هو المستويات التعليمية بعد الثانوية.

رابعاً: توحيد كيانات التعليم المتعددة في كيان واحد ومجلس واحد، لإزالة الاختلاف والتناقض الموجود حالياً، على أن ينبثق عن ذلك قطاعات تخصصية لكل نوع من أنواع التعليم، وتعمل في إطار منظومة عمل متناسقة يسودها التكامل والانسجام في تحقيق غايات وأهداف التعليم المختلفة وفق إستراتيجية موحدة.

والله من وراء القصد،،،،،

المراجع

- إبراهيم بن محمد الشافعي. (يناير، 2016). تخطيط التدريب الفني والمهني بدول مجلس التعاون لدول الخليج العربية. (المكتب التنفيذي لمجلس وزراء دول التعاون، المحرر) المنامة، المنامة، البحرين: المكتب التنفيذي لمجلس وزراء دول التعاون.
- أبكر إبراهيم صالح شوقار. (2013). النزاع وأثره على التنمية الاجتماعية والاقتصادية بدارفور. (رسالة دكتوراه غير منشورة). الخرطوم: كلية الدراسات العليا.
- أحمد عردوم. (مارس، 2017). الصراع السعودي-الإيراني وأثره على اليمن. مجلة العلوم السياسية والقانون، العدد 2، الصفحات 270-285.
- أحمد عمر، وإليان أبوه. (2 ديسمبر، 2015). أثر النزاعات المسلحة على السلوك التوافقي للتازحين والمجتمعات المضيفة. International Journal of Innovation and Scientific Research، الصفحات 423-435.
- أحمد محمد لوبوايد. (2018). الأخوة الأعداء... مستقبل العلاقات اليمنية مع دول مجلس التعاون الخليجية (المجلد الأول). القاهرة: العربي للنشر والتوزيع.
- أحمد محمد عبد الله ناصر الحسني. (مارس، 2017). قرارات مجلس الأمن ودورها في حل الأزمة اليمنية. مجلة العلوم السياسية والقانون، العدد2، الصفحات 256-269.
- أحمد مختار عمر. (2008). معجم اللغة العربية المعاصر (المجلد 1). القاهرة: عالم الكتب.
- الإدارة العامة للإحصاء. (2016). إحصائيات كلية المجتمع الحكومية. صنعاء: وزارة التعليم والتدريب المهني والتقني اليمني.
- أسماء شطيبي. (يونيو، 2018). أثر إدارة المعرفة على العنصر البشري. مجلة العلوم السياسية والقانون. العدد 09
- إياد علي الدجني. (2011). دور التخطيط الاستراتيجي في جودة الأداء المؤسسي دراسة وصفية تحليلية في الجامعات النظامية الفلسطينية. (رسالة دكتوراه غير منشورة). دمشق: جامعة دمشق.
- جهاد محمد الغنمي، ونزار راسم اللبدي، ومحمد إبراهيم المقصص. (2008). مقارنة بين ثلاث طرائق للتغويض عن القيم المفقودة في الاختبارات العامة. الجامعة الأردنية. مجلة دراسات العلوم التربوية، المجلد 45، العدد 1. الصفحات 19-35.
- زين الدين اوانغ. (2019) نمذجة المعادلة البنائية باستخدام برنامج أموس دليل مبسط لتعلم برمجة أموس. ترجمة إبراهيم مخيمر. نيرينجلو: جامعة السلطان زين العابدين.
- حسن محمد ميهوب بالحمرة. (2016). أثر تطبيق إدارة الجودة الشاملة على جودة التعليم دراسة ميدانية على جامعة سبها الليبية. (رسالة دكتوراه غير منشورة). نيلاي: جامعة العلوم الإسلامية الماليزية.
- خليل عمر أمضر، ومرشد حميد رقية. (2015). العلاقة الجدلية بين التعليم والتنمية وتقدم المجتمع. ديالى: كلية التربية بالأصمعي.
- دريس نبيل. (مارس، 2017). أهمية إدارة الجودة في الجامعة الجزائرية. مجلة العلوم السياسية والقانون العدد الثاني، الصفحات 88-99.
- رافت مأمون عبد القادر. (2016). دور التعليم الفني والتقني في التنمية الاقتصادية. رسالة ماجستير غير منشورة. الخرطوم: جامعة الزعيم الأزهي.
- زيد مصطفى حامد خويك، ونصيف عبد اللطيف نصيف، وفريد حسين أحمد. (2015). قياس جودة وأمتلية مخرجات العملية التعليمية باستخدام أسلوب البرمجة الخطية. مجلة كلية بغداد للعلوم الاقتصادية الجامعة، الصفحات 300-332.
- سليمان بن سالم الحسيني. (2016). رفع مستوى الجودة في برامج التعليم العالي عن طريق تحقيق تكامل مخرجات التعليم العالي مع متطلبات سوق العمل. (الصفحات 26-38). المؤتمر العربي الدولي السادس لضمان جودة التعليم العالي.
- شوقي عبد الحميد عبده سيف المخلافي. (2019). أثر البيئة على التغيير التنظيمي في مؤسسات الإدارة العامة في الجمهورية اليمنية. (رسالة دكتوراه غير منشورة). السودان: جامعة النيلين.
- عائشة أبكر طه. (2016). أثر النزاعات الأهلية على التعليم بمرحلة الأساس في جنوب دارفور. (رسالة ماجستير غير منشورة). الخرطوم: جامعة السودان للعلوم والتكنولوجيا.
- عبد الرحمن محمود المشرعي. (18 يناير، 2014). التعليم الفني والمهني لا يواكب متطلبات سوق العمل. صحيفة الثورة اليمنية.
- عبد الرحمن نعمان الشريف. (2017). الفجوة بين ثقافة الجودة الشاملة وتحسين أداء النظم التعليمية في الجمهورية اليمنية.
- محمود أحمد أبو سمره، ومعزوز جابر علاونه، وعمر موسى العباسي. (2008). مؤشرات إدارة الجودة في جامعة القدس من وجهة نظر طلبتها. مجلة جامعة القدس المفتوحة. العدد 12. فبراير. الصفحات 12-46.
- عماد الدين محمد الحسن أحمد. (2015). الإجراءات التطبيقية لضمان جودة التعليم الجامعي بالسودان. المؤتمر الدولي الخامس، (الصفحات 500-518). الخرطوم.
- فريق البنك الدولي. (2015). التعليم في الدول الإتحادية: الدروس المستفادة من بلدان محددة. صنعاء: البنك الدولي.
- فضلون الزهراء. (2018). لعوامل المحددة لتصور طلبة العلوم الاجتماعية لواقع العمل بعد التخرج دراسة ميدانية بجامعة العربي بن مهيدي بأم البواقي/ الجزائر. مجلة العلوم الاجتماعية إصدارات، الصفحات 129-143.
- أحمد إبراهيم خضر. (2013). إعداد البحوث والرسائل العلمية: من الفكرة حتى الخاتمة. القاهرة: شبكة الألوكة.
- اللجنة الوطنية للتعليم للجميع. (2014). الوضع التعليمي لمختلف فئات التعليم -الاستعراض الوطني في الجمهورية اليمنية. أثنون: المنتدى العالمي للتربية.
- محسن الظالمي، وأحمد الإمارة، وأفان، وعبد علي الأسدي. (30 مايو، 2012). قياس جودة مخرجات التعليم العالي من وجهة نظر الجامعات وبعض مؤسسات سوق العمل. الإدارة والاقتصاد (90)، الصفحات 147-171.
- محمد بن سالم بن محمد باعمر. (2019). أثر ممارسات إدارة الموارد البشرية على سلوك المواطنة التنظيمية من خلال السلوك التنظيمي في مؤسسات القطاع الخاص في سلطنة عُمان. (رسالة دكتوراه غير منشورة). نيلاي: جامعة العلوم الإسلامية الماليزية.
- محمد مكرم علي ابن منظور. (1994). لسان العرب (المجلد 3). بيروت: دار صادر.
- مركز الدراسات والإعلام التربوي. (2017). تداعيات الحرب وأثارها على التعليم. تعز: وحدة الدراسات والبحوث في المركز.

- مؤشر المعرفة العالمي. (2017). نتائج مؤشر المعرفة العالمي. دبي: دار الغرير للطباعة والنشر.
- نادية إبراهيمي. (2013). دور الجامعة في تنمية رأس المال البشري لتحقيق التنمية المستدامة (دراسة حالة جامعة المسيلة). الجزائر: (رسالة دكتوراه غير منشورة).
- نغم سعدون رحيمة. (2015). تأثير النزاعات المسلحة على جودة التعليم في العراق. مجلة المستنصرية للدراسات العربية والدولية، الصفحات 220-255.
- اليونسكو. (2018). مبادرة تعليم المهارات الحياتية والمواطنة في الشرق الأوسط وشمال أفريقيا. عمان: منظمة الأمم المتحدة للتربية والثقافة والعلوم.
- Afhanorhan, A., Awang, Z., Salleh, F., Ghazali, P., & Rashid, N. (2018). The effect of product quality, medical price and staff skills on patient loyalty via cultural impact in medical tourism. *Management Science Letters*, 8(12), 1421-1424.
- Afhanorhan, A., Awang, Z., Rashid, N., Foziah, H., & Ghazali, P. (2019). Assessing the effects of service quality on customer satisfaction. *Management Science Letters*, 9(1), 13-24.
- Awang, Z., Afhanorhan, A., & Mamat, M. (2016). The Likert scale analysis using parametric based Structural Equation Modeling (SEM). *Computational Methods in Social Sciences*, 4(1), 13-21.
- Bernard Ancori. (May 2016). Scientific popularization, increasing knowledge gap, and epistemology of communication. *Nouvelles perspectives in sciences sociales* .Pp. 181-232.
- Duarte, L. C. (September 2016). Impact of Armed Education and Educational Agents: A Multifocal Review. *Educate Electronic Journal*, Pp. 1-24.
- Italy Florence. (2015). Building, Proceedings of 2015 International Conference on Interactive Collaborative Learning. September 20-24. Interactive Collaborative Learning.
- Hair, J.F., Black, W.C., Babin, B.J., Anderson, R.E. & Tatham, R.L. (2006). *Multivariate data analysis*. New Jersey: Pearson Prentice Hall.
- Lea Zanola, and Michael Axmann Valentina Barucci. (2016). VET and the transition of young women and men to the lab or market in middle-income countries: a comparative analysis based on ILO surveys in Jamaica, Jordan, Peru, Tunisia, Ukraine, Vietnam and Zambia.
- Markauskaite, L. a. (2016). *Epistemic Fluency and Professional Education: Innovation, Knowledgeable Action and Actionable Knowledge*. Springer: Dordrecht.
- Ministry of Higher Education. (2017). *Technical Education and Vocational Training (TVET) in Malaysia: Selected Works*. Citation Centre Department of Higher Education. Putrajaya: Eworks Creative Enterprise.
- Moses, K. M. (26October, 2016). Improving the Quality and Competence of Technical Vocational Education and Training Output Through Vocational School Cooperation with Industry: A Case Study of Uganda. *AIP Conference Proceedings*, (pp. 1-5). Kampala.
- Phyllis Kotite. (2012). *Education for conflict prevention and peace building: Meeting the global challenges (Vol. the 21st century)*. Paris: International Institute for Educational Planning.
- Sanath Kumar, & Matthias PilzNayana Tara. (2016). Quality of TVET in India: The case of Industrial Training Institutes. Retrieved from available at TVET@ Asia, (Pp. 1-17).
- Silvia Schmelks del Valle. (March 2018). *The concept of quality in education: its structure, dimensions and evaluation*. Mexico City: Institute National for the Evaluation of Education (Spanish). Retrieved from available at: www.inee.edu.mx
- Thareja, y. (2017). *Excellence in Technical Education: The Pathway of Quality Management*. OmniScience, Pp. 7-22.
- Vidya Diwakar. (August 2015). The Effect of Armed Conflict on Education: Evidence from Iraq. *The Journal of Development Studies* (Pp. 1702-1718).

ASSESSING THE UAE'S EXPERIENCE IN INVESTING ENDOWMENTS IN EDUCATIONAL ASPECTS

Moza Al Suwaidi

ورقة عمل بعنوان

تجربة دولة الإمارات العربية المتحدة في استثمار الأوقاف في الجوانب التعليمية

اعداد باحثة الدكتوراه: موزة راشد السويدي

2020م

تمهيد:

لم تقتصر مهمة إدارة الوقف في تجارب الدول المتقدمة والنامية على جانب واحد بل اشتملت على جوانب متعددة منها الجوانب الاجتماعية والثقافية والاقتصادية والصحية، ومن ذلك المساهمة في مجالات التعليم المختلفة، مما وفر لهم مناخاً مستقراً يشجعهم على الإنتاج العلمي وتوفير كل احتياجاتهم، ولقد قامت العديد من الدول الأجنبية والعربية بتجارب في استثمار الأوقاف لتطوير المؤسسات التعليمية والنهوض بها، حيث أن إدارة الوقف تقوم بأدوار تنموية لتحقيق الحاجات الأساسية لطبقات المجتمع المختلفة، بالإضافة إلى توفير التعليم المجاني من خلال المؤسسات التعليمية وذلك لتحقيق الرفاهية الاجتماعية لأبناء المجتمعات في الجوانب التعليمية، هذا وقد تحملت إدارة الوقف مسؤولية التعليم بكافة نواحيه حتى بناء المدارس أو توفير المنشآت المدرسية، بل قامت بتوفير احتياجات الطلاب من أوراق وأدوات (أقلام/ أحبار) وخزائن للكتب، ومكتبات وسكن وطعام. وتتلخص أهداف الدراسة في الآتي: التعرف على العلاقة بين الوقف والاستثمار، وبيان تطبيق الاستثمار في التعليم بدولة الإمارات العربية المتحدة.

أما أهم النتائج التي تم توصلت إليها الورقة هي كالآتي:

1. حرص واهتمام دولة الامارات العربية المتحدة بوقف التعليم

2. ساهم وقف التعليم في مساعدة العديد من الطلبة المعسرین في التعلم

تجربة دولة الإمارات العربية المتحدة في استثمار الأوقاف في الجوانب التعليمية

أولاً : العلاقة بين الوقف والاستثمار:

ثمة علاقة قوية بين الوقف والاستثمار ولمعرفة هذه العلاقة لابد من الوقوف على معنى المصطلحين حتى يتسنى لنا إدراك هذه العلاقة ؛ نوضح معنى المصطلحين كما هو أدناه:

وردت عدة تعاريف للوقف من السادة العلماء أبرزها تعريف السادة الحنابلة وهو: " تحبيس الأصل وتسييل المنفعة (حسن ، 2019)، أما قانون الوقف الإماراتي رقم 5 لسنة 2018 فقد عرف الوقف بأنه: " تسييل منفعة بمفردها أو تسييل منفعة مع حبس أصل العين الموقوفة والحفاظ عليها من الضياع".

أما الاستثمار فهو: " تنمية المال بسائر الطرق المشروعة، واستثمار الأوقاف: و احداث النماء والزيادة بكل سبيل مشروع من الربح والغلة والفائدة والكسب، وذلك باستغلالها في وجوه الاستثمار المتعددة " (الرحيلي، 2005)

إن لفظ الاستثمار لم يرد في كتب اللغة بمعناه الاقتصادي، ولذلك يعرف في معجم الوسيط بأنه: " استخدام الأموال في الإنتاج إما مباشرة بشراء الآلات، وإما بطريقة غير مباشرة ك شراء الاسهم والسندات" (إبراهيم مصطفى، وآخرون، 2010)

والعلاقة بين الوقف والاستثمار علاقة كبيرة، فالوقف في حقيقته استثمار، حيث إن صاحبه يريد أن يقف ماله في سبيل أن يحصد نتاجه يوم القيامة، ومن حيث الحفاظ على الأصل، ويكون الاستهلاك للنتاج والثمرة والربح والريع، فالأعيان الموقوفة إما أن تنتج منها الثمار كما هو الحال في وقف الأشجار والبساتين المثمرة، أو تنتج منها منفعة وأجرة كما هو الحال بالنسبة للأعيان المستأجرة، أو ينتج منها ربح وريع كما هو الحال بالنسبة لوقف النقود.

ومن المقاصد الأساسية للوقف تقديم المنافع للمستفيدين منه الناجمة عن غلة الأعيان أو من عوائد الأموال المستثمرة، وتطبيقاً لأساس التأييد واستمرارية المنافع، قد ترى إدارة أموال الوقف إعادة استثمار جزء من العوائد النقدية بدلاً من توزيعها كلها، بهدف تنمية الأموال بضوابط معينة، من أهمها:

1. الالتزام بحجة الوقف ما لم يحدث تغييراً يخرجها عن جدواها.
2. تحقيق التوازن بين مصالح الأجيال الحاضرة والأجيال المقبلة من المستفيدين، ولا سيما في ظل التضخم وانخفاض القيمة الاقتصادية لأموال الوقف، ففي مثل هذه الحالة يتم توزيع جزء من العوائد وإعادة استثمار الجزء الآخر.
3. الاحتياط لاستبدال الأصول المستثمرة بغيرها في ظل ارتفاع الأسعار، ففي مثل هذه الحالة يجوز تجنب جزء من العوائد في صورة احتياطات لاستبدال الأصول وذلك قياساً على ما ورد بشأن مخصص الصيانة والترميم.
4. سهولة تسهيل الاستثمار عند الحاجة إليها. (عيسى، 2014)

ثانياً : الجانب التشريعي والتطبيقي الداعم للاستثمارات الوقفية في التعليم.

اهتمت دولة الإمارات العربية المتحدة بالاستثمار في المؤسسات التعليمية التي تخضع تحت إدارة الوقف في معظم أنحاء الإمارات السبع (إمارة أبوظبي - إمارة دبي - إمارة الشارقة - إمارة عجمان - إمارة أم القيوين - إمارة رأس الخيمة - إمارة الفجيرة)، وقد أصدرت العديد من القوانين التي تقوم بتنظيم وتنسيق إدارة الوقف، وسوف نوضح ذلك من خلال الآتي:

1 - الجانب التشريعي للوقف التعليمي في دولة الإمارات العربية المتحدة

إن الوقف في دولة الإمارات العربية المتحدة ينقسم إلى نوعين رئيسيين: أوقاف اتحادية تمارس دورها على مستوى اتحاد الإمارات، وأوقاف محلية تمارس دورها على مستوى الحكومات المحلية، وداخل هذين النوعين تعددت أشكال الوقف وأنواعه " (حسن، 2019)

ولقد تمت تشريعات وقفية وقوانين منظمة لإدارة الوقف في دولة الإمارات العربية المتحدة، على خطوتين:

تمثلت الخطوة الأولى في التشريع والتقنين، وكان ذلك مع بداية عام 1983م بصدر قانون اتحادي لتنظيم الوقف، تلاه قانون الإجراءات والإثبات في الأحوال الشخصية والوقف متبوعاً بمذكرة إيضاحية تختص بمشروع قانون اتحادي عن الوقف وحدوث المراجعة لمشروع الاتحاد فيما يخص الوقف عام 1997م (الجميل، 2017).

وتمثلت الخطوة الثانية في التنظيم الوقفي داخل الدولة، والذي تم عن طريق تشريعات مالية وإدارية منها:

صدر مشروع قانون خلال عام 1984م عن قيام الهيئة العامة للأوقاف الخيرية، وخلال عام 1991م تم صدور القرار الوزاري الخاص بتحديد رواتب القائمين على إدارة الوقف، وقرار آخر خلال عام 1993م يختص بالنظام المالي والإداري للأوقاف، وكذلك تشكيل اللجنة العليا للأوقاف، وتبعها صدور قرار بتعيين ملاك للوقف، ثم قانون تنظيم إجراءات الوقف في عام 1997م، تلاه مشروع قرار الذي يختص بقيام الهيئة العامة للأوقاف مقترح في عام 1997، وفي نفس العام تم صدور قرار وزاري مقترح بنظام عمل الصناديق الوقفية (الجميل، 2017).

وفي عام 1999 تم تأسيس الهيئة العامة للشؤون الإسلامية والأوقاف بمرسوم اتحادي رقم 29 وهو يعنى بالوقف، وتسعى الهيئة إلى تنمية واستثمار موارده ضمن الأطر الشرعية الخاصة بالوقف... وقد أشارت المادة رقم 5 من القانون بجواز ضم أوقاف أي إمارة للهيئة بناء على طلب الإمارة (حسن، 2019)

وقد تشرف الشيخ "سلطان بن محمد القاسمي"، حاكم الشارقة وعضو المجلس الأعلى بإصدار القانون الذي حمل رقم (4) للعام 2011 م، وفيما يختص بإدارة الوقف داخل إمارة الشارقة، ونصت مواده التي بلغت (58) مادة تضمنت أنواع الوقف الخيري، وإجراءات حمايته، واستغلاله واستثماره، وما يشترط فيمن يتولى نظارة الوقف، والحالات التي يتم عزله فيها، بالإضافة إلى الحالات التي يتحدد منها انتهاء مدة الوقف (موقع دائرة الأوقاف بالشارقة، 2018).

وقد صدر بتاريخ 2017/4/4م إعلان الهيئة العامة للشؤون الإسلامية والأوقاف بأبوظبي لمسودة لمشروع كامل (موقع: الهيئة العامة للشؤون الإسلامية والأوقاف، 2018)، وقد وضع القانون الاتحادي رقم (5) لعام 2018م، والذي تم تفعيله في دولة الإمارات العربية المتحدة والمتضمن (40) مادة عن إدارة الوقف، وقوانين تنظيمه والاستثمار فيه ليعمل لصالح المواطنين ويلبي متطلباتهم المختلفة، كما يساهم في تقنين شؤون الوقف من الأعمال الإدارية وطرق تنمية إيراداته، والعمل على تهيئة مناخ ملائم للعمل الوقفي ودعم التعليم.

2- الجانب التطبيقي لاستثمارات الأوقاف في التعليم :

لقد أدركت الدولة أهمية الاستثمار وخاصة فيما يتعلق بالجوانب التعليمية داخل الإمارات العربية المتحدة بالمبادرة العالمية التي دعا إليها الشيخ "محمد بن راشد آل مكتوم" نائب رئيس دولة الإمارات العربية المتحدة، وحاكم إمارة دبي لمحاولة إحياء الوقف، وتشجيع مشاريع للوقف والهبات بما تقدر قيمته بخمسة مليارات درهم إماراتي، برعاية إدارة تستثمر تلك الأموال في الدعم التعليمي للمجالات المختلفة، من تعليم وعلوم ومعرفة وأبحاث مستقبلية، وتشجيع القراءة، وتشكل مثل تلك الإجراءات مساندة من المسؤولين الإماراتيين للبعد الاجتماعي للتعليم وللتدابير التي تقي بمتطلباته، بجانب الإفادة من التجارب العالمية لإنشاء وإدارة مؤسسات الوقف والهبات عبر تحديد احتياجات المجتمع الإماراتي والعمل على تطوير سياسات ملائمة لتنفيذها (الفرقاوي، 2016).

ولا شك إن دولة الإمارات العربية المتحدة تساند القطاع التعليمي؛ وتشجع مؤسسة إدارة الأوقاف وشؤون القصر عبر خدمات مصرف التعليم، باقتطاع جزء من دخله لدعم الطلاب وتوفير مستلزماتهم، ومساندة المتفوقين منهم، ولطلاب الدراسات العليا، وتقديم دعم ورعاية للمواهب العلمية والثقافية، والتشجيع على الاهتمام بالتعليم، وخدمة مجالات العلم والثقافة بتوفير مدارس مجهزة ومزودة بمعلمين مؤهلين، بجانب نشر المكتبات المجهزة بما يلزم من كتب متنوعة للمساهمة في رفع مستوى الإنسان وتطور المجتمع (مؤسسة الأوقاف وشؤون القصر، 2018).

كما يتضح الاستثمار في الجوانب التعليمية من خلال الاستثمار في رأس المال البشري حيث خصصت الهيئة العامة للشؤون الإسلامية والأوقاف مصرف خاص بالتعليم وهو مصرف العلم: " هو وقف يخصص ريعه لخدمة العلم وأهله وبناء ورعاية مراعاة وتوفير مستلزماته، ويتضمن المجالات التالية: كفالة طالب العلم، وإعداد العلماء، دعم إعداد الدراسات والأبحاث وتأليف الكتب وطباعتها، وإنشاء المدارس والعناية بها وتوفير مستلزماتها، ومن أهداف المصرف: التشجيع على طلب العلم والارتقاء به لخدمة الفرد والمجتمع، وتأهيل الطلبة علمياً ومهرياً لمواكبة التغيرات وفق ضرورات المجتمع وحاجاته، ودعم الأبحاث العلمية وفتح الآفاق أمام الاختراعات والإبداعات العلمية. (موقع الهيئة العامة للشؤون الإسلامية والأوقاف، 2020)

أما على المستوى المحلي فهناك الأوقاف الآتية:

- دائرة الأوقاف والشؤون الإسلامية في دبي بقانون رقم 6 لسنة 1994
- الأمانة العامة للأوقاف في الشارقة بمرسوم أميري رقم 2 لسنة 1996
- صندوق عجمان رقم 1 لسنة 1996 (حسن، 2019)

أما عن الوقف الخاص والذي يعود للأفراد والعائلات الإماراتية هناك؛ فنورد لكم بعض من أوقاف تجار دبي؛ فقد أوقف: " السيد جمعة الماجد الذي أسس عام 1986 من خلال مؤسساته الوقفية ذات الصبغة التعليمية؛ مركز جمعة الماجد للثقافة والتراث، وكلية الدراسات العربية والإسلامية، والمدارس الأهلية الخيرية بالشارقة وعجمان ودبي... كما أوقف الحاج سعيد لوتاه مؤسسات ووقفية تعليمية وتربوية عام 1995 ومن أبرزها جامعة لوتاه، والمدرسة الإسلامية وهي مدرسة وفاقية" (حسن، 2019)

كما أوقف معالي عبدالله الغرير ثلث ثروته للجانب التعليمي (الجميل، 2017)، كما قامت مؤسسة عيسى صالح القرقي بتقديم دعم مالي لتعليم الطب في جامعة محمد بن راشد للطب والعلوم الصحية (حسن، 2019)

وتجدر الإشارة إلى أن من خلال إحصاءات الوقف لعام 2015 إلى عام 2018 في دبي بلغ عدد المستفيدين في مجال التعليم، 11 مدرسة، وتزويدهم بـ 265 جهاز تعليمي وقد تم دعم الطلاب المعسرین على مستوى اماره دبي بمبلغ 2 مليون درهم (حسن ، 2019 : 154) أما عن صندوق عجمان، يتضح اهتمامه بمصرف العلم: " حيث خصص ثلاثة ملايين درهم مقسمة على النحو الآتي: مليون درهم للأنشطة الطلابية المتنوعة، ومليون الأجهزة التعليمية، ومليون درهم لتسييد رسوم الطلبة المحتاجين في مراحل التعليم العام والجامعي. ومن الأهمية بمكان الإشارة إلى وجود مؤسسات كان لها دور بارز وكبير تمولا واستثمارا وهي: " مركز محمد بن راشد العالمي للاستشارات والهبة بدبي، ومؤسسة الشيخ زايد بن سلطان آل نهيان للأعمال الخيرية والإنسانية في أبوظبي، والمؤسسة العربية للعلوم والتكنولوجيا الشارقة" (الجميل، 2017).

لقد سخرت دولة الإمارات العربية المتحدة جميع السبل، وهيأت جميع الفرص للوقف بجميع أنواعه ومنه وقف التعليم، فالتعليم من أهم القطاعات التي تحتاج إلى دعم، كما أنها فتحت المجال للمتبرعين من المحسنين في الدولة من خلال قنوات عديدة للمساهمة في وقف التعليم للنهوض بالحركة العلمية في الدولة، وللمساعدة المتفوقين المعوزين، وصرف رواتب المعلمين وتقديم المكافآت للطلبة وتشجيعهم، ومدهم بالمستلزمات الدراسية من الحاسبات وغيرها مما يدعم عملية التعليم ويساهم في بناء الكوادر العلمية كاستثمار في رأس المال البشري، وهذا الأمر يذكرنا بما كانت عليه الحضارة الإسلامية وقيامها بالنهضة العلمية في بلاد المسلمين: " فكان دور المال الوقفي في تهيئة جيل من الكوادر العلمية قادرا على مد الدولة بكل الاحتياجات والإمكانات، ولم يكن هذا المال خاصة بفئة دون أخرى، بل جاء لطبقات المجتمع ككل وخاصة طبقة الفقراء والمحتاجين الذين استفادوا من الأموال الوقفية خير استفادة وكونوا الحمة متينة للمجتمع". (الصلاحات، 2004)

الخاتمة

لا شك أن استثمار أموال الوقف يؤدي للحفاظ عليها حتى لا تأكلها النفقات والمصاريف، ويساهم في تحقيق أهداف الوقف الاجتماعية والاقتصادية والتعليمية، والتنمية، فالدول الإسلامية في حاجة إلى هذا الوقف لتحسين أحوالها الاجتماعية والاقتصادية؛ من خلال استثمار الأموال عن طريق التسويق والتصنيع والإنتاج.

إضافة إلى ذلك فإن الوقف الذي يراد له الاستمرار والديمومة لا يمكن أن يتحقق من خلال الاستثمارات الناجحة المدروسة بطريقة قائمة على أسس علمية، وإلا فالمصاريف والنفقات والصيانة قد تقضي على أصل الوقف مما يحرم المستفيدين من هذا الوقف، لذلك ينبغي أن تهتم إدارة الوقف (أو الناظر) بهذا الجانب اهتماماً كبيراً وتخصص جزءاً جيداً من ريع الوقف للاستثمار والتنمية.

التوصيات

- إقامة المؤتمرات التي تفسح المجال لتلاقح الأفكار والاستفادة من تجارب الدول في مجال الاستثمار الوقفي في التعليم
- اطلاق منصة عالمية تفاعلية للوقف يتم فيها الاستفادة من خبرات العلماء المتخصصين والعاملين في المجال الوقفي الاستثماري وبالذات في الجانب التربوي والتعليمي.
- اطلاق جائزة الوقف العالمية لتكريم النخبة والصفوة من العاملين في الوقف وخاصة من لهم بصمات في الوقف التعليمي.

قائمة المراجع

1. إبراهيم مصطفى، أحمد الزيات، حامد عبد القادر، محمد النجار، المعجم الوسيط، القاهرة، مجمع اللغة العربية، 2010، (1/100) مادة "ثمر".
2. ابن قدامة، المغني، عبد الله التركي، القاهرة، دار عالم الكتب، 1997، (640/5-641)
3. الجميلي، عمر عبد عباس (2017). الوقف التعليمي وأثره في التنمية، دولة الإمارات العربية المتحدة نموذجاً، دبي: دائرة الشؤون الإسلامية والعمل الخيري.
4. حسن، إسماعيل محمد (2019) الوقف المبتكر، بحث ماجستير، كلية الإمام مالك للشريعة والقانون: الإمارات العربية المتحدة
5. رضا محمد عيسى، أحكام استبدال الوقف في النظامين المصري والسعودي، الرياض، مكتبة القانون والاقتصاد، 2014، ص 45.
6. الرحيلي. محمد 2005 بعنوان " استثمار أموال الوقف " مؤتمر الشارقة للوقف الإسلامي والمجتمع الدولي
7. الصلاحات، سامي (2004). دور الوقف في تفعيل التعليم الجامعي في الجامعات الإسلامية، بحث منشور في المملكة المغربية، اتحاد الجامعات الإسلامية، ايسيكو، مجلة الجامعة
8. قانون الوقف الاتحادي رقم (5) لسنة 2018 في دولة الإمارات العربية المتحدة
9. الفرقاوي، محمد (2016). رؤية دبي العالمية للأوقاف والهيئات، دبي: مؤتمر عن إطلاق مبادرة دبي للأوقاف، 24 مارس.
10. محمد الخرشني أبو عبد الله، علي العنوي، الخرشني على مختصر سيدي خليل وبهامشه حاشية العنوي، القاهرة، المطبعة الأميرية الكبرى، 2014، (7/80)

THE ORGANIZATIONAL AND PRACTICAL FRAMEWORK FOR THE INTERNAL AUDIT FUNCTION IN THE UNITED ARAB EMIRATES

Hussain Khalil Asemsi

United Arab Emirates

عنوان الورقة البحثية: الإطار التنظيمي والتطبيقي لوظيفة التدقيق الداخلي في دولة الإمارات حسين خليل الشمسي، الإمارات العربية المتحدة

1. الملخص

لازالت الحكومات وشركات القطاع العام فضلا عن شركات القطاع الخاص، تعيش تحديات كبيرة في مواجهة قضايا الحوكمة والفساد والغش والاحتيال، ومعوقات تحول دون قيام أجهزة الرقابة الحكومية تحديدا بملعبها بالشكل المطلوب لأسباب منها غياب القوانين الكافية وضعف الالتزام بها. وتحديات أخرى منها ضعف الاهتمام بدور التدقيق الداخلي، والذي يجب العمل عليه لزيادة تقبل المؤسسات والموظفين لوجود ودور المدقق الداخلي بينهم من أجل تطوير المؤسسات وإعداد الميزانيات السليمة، والتطور الحاصل في مجال التدقيق الأخذ بالتطور سريعا إلى جانب تأثير الذكاء الاصطناعي والأنظمة الذكية والتطور التكنولوجي على هذا المجال.

ويأتي هذا البحث لتسليط الضوء على الإطار التنظيمي والتطبيقي لوظيفة التدقيق الداخلي في دولة الإمارات، وكيف اتجهت حكومة دولة الإمارات للاستفادة من التطورات الخاصة في ميادين العلم والمعرفة لتعزيز كفاءة أنشطة التدقيق الداخلي في الجهات الحكومية.

ويهدف هذا البحث إلى استعراض واقع التدقيق الداخلي في دولة الإمارات العربية المتحدة والوقوف على جوانب الكفاية أو القصور فيه، مع تعزيز دور الرقابة الحكومية على مختلف الجهات والوحدات الحكومية استنادا إلى القوانين والتعليمات واستخدام وسائل الحديثة في العمل فضلا عن تطوير أداء العاملين في أجهزة الرقابة الحكومية بما يساعد في اصلاح وتعزيز منظومة الرقابة الحكومية، وأسفر البحث عن جملة من الاستنتاجات أبرزها: مبادرة حكومة الإمارات منذ قيام الدولة على إنشاء جهاز للرقابة المالية بإنشاء ديوان المحاسبة عام 1976، وصدر الإطار العام لعمل ديوان المحاسبة في الرقابة على الجهات الاتحادية، وأن أغلب الإمارات لديها أنظمة وقوانين وتشريعات محلية ولكنها في الاجمال متوافقة مع النظام الاتحادي. كما اعتمدت الحكومة الاتحادية لدولة الإمارات سنة 2019 دليل ميثاق ومنهجية التدقيق الداخلي للحكومة الاتحادية وهذا الدليل يتوافق مع الإطار المهني الدولي للممارسة أعمال التدقيق الداخلي والمعايير والإرشادات الدولية للممارسات المهنية للتدقيق الداخلي كما هي محددة من هيئات دولية مثل معهد المدققين الداخليين. وحدد هدف هذا الميثاق لتحقيق فاعلية نشاط التدقيق الداخلي من خلال الممارسات الحديثة وهي (الاعتماد على تحديد وتقييم المخاطر الاستراتيجية، تطوير إجراءات الرقابة، إضافة القيمة عن طريق تقديم التوصيات والمقترحات اللازمة، الحرص على عدم تكرار الأخطاء وتلافيا).

2. مفهوم التدقيق الداخلي ونشأته والتطور التاريخي والأهداف

يمكن فهم التدقيق الداخلي من خلال استعراض التعريفات الواردة في الأبيات والمراجع العلمية:

التعريف رقم (1) ورد تعريف في معجم المعاني الجامع - معجم عربي عربي - معنى تدقيق داخلي بأنه "تدقيق حسابات الشركة من قبل أحد موظفيها" (المعاني، 2019)

التعريف رقم (2) تشير التعريفات القديمة للتدقيق الداخلي على أنه نشاط هادف ومستقل بذاته، يؤدي عملا استشاريا، صمم خصيصا لزيادة قيمة الشركة وتطوير عملياتها، ولمساعدها بلوغ أهدافها عن طريق إيجاد سلوكيات وأنماط تنظيمية لتقييم وتحسين فعالية إدارة المخاطر وضبط إدارة العمليات والتحقق من فعالية إجراءات الضبط الداخلي والأنظمة المتعددة (صباح، 2010)

ووفقا لقاموس المصطلحات المالية الأكثر استخداما في الأسواق المالية (اتحاد هيئات الأوراق المالية العربية. دبي . 2018)، فإن التدقيق الداخلي له تعريفان:

التعريف رقم (3): التدقيق الداخلي (المحاسبي) هو اختبار وفحص اجراءات المنشأة وعملياتها من قبل المدقق الداخلي للتحقق من امتثالها لسياسات المنشأة

التعريف رقم (4): التدقيق الداخلي (المحاسبي) هو عبارة عن آليات وإجراءات تفقيعية ينفذها المدققون الداخليون، والتي تركز على تطبيق سياسات الإدارة والتحقق من وجود أنظمة جيدة للرقابة الداخلية والكشف عن سوء استعمال الأموال.

التعريف (5) أنها عمليات التدقيق والفحص للمستندات والسجلات والدفاتر، التي تتم بصفة منتظمة ومستمرة ويقوم بها مجموعة من المدققين من داخل المنشأة معينين لهذا الغرض، بهدف اكتشاف الأخطاء والغش، وتقديم تقارير دورية عن نتائج أعمالها إلى الإدارة لتساعدها في وظائفها. (شحاته. دت).

التعريف رقم (6): أداة مستقلة تعمل من داخل المشروع والحكم والتقييم ولخدمة أهداف الإدارة في مجال الرقابة عن طريق تدقيق العمليات الحسابية والمالية، ويمثل التدقيق الداخلي أحد حلقات الرقابة الداخلية وأداة في يد الإدارة تعمل على مزايا الإدارة باستمرار بالمعلومات فيما يتعلق بالنواحي التالية:

دقة أنظمة الرقابة الداخلية، الكفاءة التي يتم بها التنفيذ الفعلي للمهام داخل كل قسم من أقسام المشروع، كيفية وكفاءة الطريقة التي يعمل بها النظام المحاسبي لكي يعكس بصدق نتائج العمليات. (نور الدين، 2015).

التعريف رقم (7): نشاط مستقل داخل المنشأة يهدف إلى التأكد من دقة وفاعلية الأنظمة والتعليمات والإجراءات المطبقة في المنشأة وتزويد الإدارة بتقارير عن أي انحرافات أو ضعف نشاط. (المؤسسة العامة للتعليم الفني. دت).

التعريف رقم (8): التدقيق الداخلي هو نشاط مستقل وموضوعي، يقدم تأكيدات وخدمات استشارية بهدف إضافة قيمة للمؤسسة وتحسين عملياتها، ويساعد هذا النشاط في تحقيق أهداف المؤسسة من خلال اتباع أسلوب منهجي منظم لتقييم وتحسين فاعلية عمليات الحوكمة وإدارة المخاطر والرقابة. وفقا لآخر

نشرة الكترونية صادرة عن معهد المدققين الداخليين الأمريكي (IIA، 2019).

والتعريف الأخير من قبل معهد المدققين الداخليين الأمريكي هو الأحدث والأكثر قبولا حاليا في أغلب الدراسات والأبحاث التي تم الاطلاع عليها.

التعريف رقم (9) - التدقيق الداخلي هو وظيفة تقييم مستقلة أنشئت داخل المنشأة لفحص وتقييم أنشطتها بهدف خدمة إدارة المنشأة، ويحدد هذا التعريف الأركان الأساسية لوظيفة المدقق الداخلي بأنها: أ - الاستقلال ب - التقييم ج - العمل داخل المنشأة د - فحص وتقييم هـ - الأنشطة و - الخدمة ز - إدارة المنشأة.

التعريف رقم (10) التندقيد الداخلي: هو التقييم المستقل لمختلف العمليات وأنظمة الرقابة داخل المنشأة وللتحقق من أن السياسات والاجراءات الموضوعية متبعة فعلا. بمعنى أن المعايير التي حددتها الادارة قد تحققت، والموارد المتاحة قد استخدمت بكفاءة وفاعلية وبدون إسراف، والخطط الموضوعية تم تنفيذها بكفاءة، وأن أهداف المنشأة قد تحققت (عبدالرزاق . د ت) .

3. إطار نظري عن دولة الإمارات العربية المتحدة

3.1 نبذة عامة عن دولة الإمارات العربية المتحدة

إن الباحث عن تاريخ دولة الإمارات العربية المتحدة ينبغي له الوقوف عند محطات مهمة في حياة هذه الدولة، لاسيما تجربتها الوجودية التي أصبحت مثالا يحتذى به بين دول العالم.

3.2 حضارة دولة الإمارات العربية المتحدة

إن الأمة التي لا تعرف ماضيها وتهمل تدوينه لن تتمكن من قيادة حاضرها ولا صياغة مستقبلها. وهو ما أكده المرحوم الشيخ زايد بن سلطان آل نهيان رئيس دولة الإمارات العربية المتحدة، حين قال: "من لا يعرف ماضيه لا يستطيع أن يعيش حاضره أو مستقبله"، ونحن في دولة الإمارات العربية المتحدة "لسنا أمة طارئة على التاريخ" كما قال صاحب السمو الشيخ محمد بن راشد آل مكتوم، نائب رئيس الدولة، رئيس مجلس الوزراء، حاكم دبي، قناريخ الإمارات ممتد لما يقرب من سبعة آلاف سنة، وفق ما أثبتته النقوش والرسوم واللقى الأثرية للبعثات العالمية منذ مطلع الخمسينيات من القرن المنصرم حتى تاريخه. (الأرشيف الوطني - قيام الاتحاد)

3.3 التهيئة لقيام دولة الإمارات العربية المتحدة

أكد المرحوم الشيخ زايد بن سلطان آل نهيان، فور توليه سدة الحكم في السادس من آب/ أغسطس عام 1966م حاكماً لإمارة أبو ظبي، مدى أهمية الاتحاد، وقال معلقاً: "نستطيع بالتعاون وبنوع من الاتحاد، اتباع نموذج الدول الأخرى النامية". وبعد إعلان البريطانيين عام 1968 عن نيتهم الانسحاب من منطقة الإمارات المتصالحة، بدأ الشيخ زايد بن سلطان آل نهيان بالتحرك سريعاً لتعزيز الروابط مع إمارات الساحل المتصالح. (نفس المصدر السابق)

3.4 تأسيس دولة الإمارات العربية المتحدة:

الإمارات العربية المتحدة دولة اتحادية تأسست في 2 ديسمبر 1971 وتتكون من سبع إمارات هي: أبو ظبي، ودبي، والشارقة، وعجمان، وأم القيوين، ورأس الخيمة، والفجيرة. وتعد الدولة واحدة من الدول الأكثر استقراراً على مستوى العالم في التاريخ الحديث، إضافة إلى ريادتها في مجالات الاقتصاد، والاستقرار الاجتماعي والأمني. (نفس المصدر السابق)

3.5 إعلان قيام دولة الإمارات العربية المتحدة

وفي 18 يوليو 1971م، قرّر حكام ست إمارات من الإمارات المتصالحة، هي: أبو ظبي، ودبي، والشارقة، وعجمان، وأم القيوين، والفجيرة، تكوين الإمارات العربية المتحدة.

وفي الثاني ديسمبر 1971م، اجتمع حكام الإمارات الست وتم الإعلان رسمياً عن تأسيس دولة مستقلة ذات سيادة. و صدر عن هذا الاجتماع البلاغ التاريخي الذي جاء فيه: "يُعرف المجلس الأعلى هذه البشري السعيدة إلى شعب الإمارات العربية المتحدة وكل الدول العربية الشقيقة، والدول الصديقة، والعالم أجمع، معلناً قيام دولة الإمارات العربية المتحدة دولة مستقلة ذات سيادة، وجزءاً من الوطن العربي الكبير."

تم الاتفاق رسمياً على وضع دستور مؤقت ضم 152 مادة، وارتكز على نسخة معدلة من نص الدستور السابق لإمارات الخليج التسع. واعتمدت أبو ظبي كعاصمة مؤقتة للاتحاد. وانتخب حاكم أبو ظبي، الشيخ زايد بن سلطان آل نهيان، من قبل الحكام ليكون أول رئيس لدولة الإمارات العربية المتحدة، وأعيد انتخابه بعد انتهاء فترة خمس سنوات. وتم انتخاب المغفور له الشيخ راشد بن سعيد آل مكتوم نائباً للرئيس، وهو منصب استمر فيه حتى وفاته عام 1990م.

وحدد الدستور خمس سلطات للدولة الاتحادية هي:

1. المجلس الأعلى للاتحاد: ويتكون من الحكام السبعة، وهو أعلى المؤسسات في الدولة، ويتخذ قراراته بالأكثرية على أن تكون كل من أبو ظبي ودبي ضمن الأكثرية
2. رئيس الدولة ونائبه
3. مجلس الوزراء
4. المجلس الوطني الاتحادي، وهو مجلس استشاري ضم في ذلك الوقت 34 عضواً، ثمانية أعضاء لكل من أبو ظبي ودبي، ستة من إمارة الشارقة، وأربعة للإمارات المتبقية. ويخصص لرأس الخيمة 6 مقاعد عند انضمامها للاتحاد ليصبح عدد الأعضاء 40 عضواً
5. السلطة التشريعية أو القضائية، وتتكون من عدد من المحاكم على رأسها المحكمة الاتحادية

3.6 اكتمال الاتحاد بين الإمارات السبع

لقد انضمت إمارة رأس الخيمة للاتحاد في وقت لاحق، حين تلقت تأكيدات من حكومة الاتحاد أن الدولة ستتابع قضية استعادة جزر ظنب الصغرى و ظنب الكبرى التابعتين للإمارة، واللتين تم احتلالهما من إيران. وتقدمت رأس الخيمة في 1971/12/23 بطلب الانضمام إلى الاتحاد، وفي 1972/2/10 تمت الموافقة على قبولها في عضوية الاتحاد بقرار صادر من المجلس الأعلى، وبذلك اكتمل كيان الاتحاد، والذي أصبح يعرف رسمياً بدولة الإمارات العربية المتحدة.

ومن العوامل التي أدت لقيام الاتحاد بين الإمارات السبع:

اللغة المشتركة، الدين، تشابه العادات والتقاليد، تكامل التضاريس وتداخلها، الموارد المتماثلة، تقاسم المصالح والطموحات. كما تتمتع دولة الإمارات العربية المتحدة بالاستقلال التام والسيادة الكاملة، وشعب كافة الإمارات واحد، ولمواطنيه جنسية واحدة وهي جنسية دولة الإمارات العربية المتحدة. وللاتحاد علمه، وشعاره، ونشيدته الوطني. (البوابة الرسمية لدولة الإمارات - تأسيس دولة الإمارات)

رفع علم تأسيس الدولة: بدأت المحادثات الوجودية بين شيوخ منطقة الخليج العربي منذ اكتشاف النفط مع بدايات 1960، وقد كان لتولي صاحب السمو المغفور له - بإذن الله تعالى - الشيخ زايد بن سلطان آل نهيان - رحمه الله - مقاليد الحكم في إمارة أبوظبي عام 1966 أثر إيجابي ودافع قوي لإتمام النوايا، فقد كان سموه - رحمه الله - مثال الرجل العربي الأصيل الذي يرى مستقبل وطنه من خلال الوحدة العربية واتفق الآراء، وتشارك المصالح والأهداف والتخطيط.

عُرِفَت الدولة الحديثة باسم دولة الإمارات وفي العام نفسه كانت شركات النفط البريطانية قد بدأت بخسارة عقودها النفطية لصالح الشركات الأمريكية؛ مما أدى إلى تقليل نفوذها في المنطقة وإضعافه؛ وهذا أعطى دافعاً جديداً؛ فتمكن شيوخ المنطقة من تأسيس ما يعرف بـ (مجلس الإمارات المتصالحة)، وتم تعيين "عدي البيطار" المستشار القانوني للمغفور له - بإذن الله تعالى - الشيخ راشد بن سعيد آل مكتوم كأمين عام ومستشار قانوني للمجلس الذي تم حله بمجرد إعلان قيام دولة الإمارات العربية المتحدة. (موسوعة الإمارات).

لقد حظيت الإمارات عامة، وأبوظبي، ودبي، والشارقة خاصة، باهتمام عالمي؛ لتقييمها - على مستوى الفرد - الفرص الاقتصادية واسعة النطاق، إضافة إلى التسهيلات الرياضية والترفيهية، والنشاطات الثقافية وتنمية الوعي لحماية البيئة والحياة البرية وتشجيع السياحة. ويمكن نجاح النظام السياسي في دولة الإمارات العربية المتحدة في أنها تمثل مزيجاً فريداً من القديم والحديث، مع التزام فطري بالإجماع والمناقشة والديموقراطية المباشرة. كُنت تضحيات ومنجزات الأباء قد ساهمت في بروز الدولة الحديثة بدلاً من الإمارات المسقلة القديمة. إن دولة الإمارات العربية المتحدة هي الدولة الاتحادية الوحيدة في العالم العربي التي لم تبق وتستمر فحسب، بل إنها قد نجحت أيضاً في تكوين واستخراج هوية قومية مميزة مع مرور الزمن. لقد صرّح الشيخ زايد رحمه الله بمناسبة الاحتفال بمرور خمس وعشرين سنة من النجاح الذي حققه الاتحاد بكل فخر واقتناع: "إن كل ما تم إنجازُه قد فاق توقعاتنا بعون من الله تعالى، ثم بعزم وإرادة قوية وصادقة، ما يؤكد أنه ليس هناك شيء لا يمكن تحقيقه لخدمة الشعب ما دام العزم ثابتاً وقوياً، وما دامت النيات صادقة". إن اتحاد الإمارات العربية المتحدة لا يزال - وسوف يستمر بإذن الله - مصدر فخر أجيال الإماراتيين الحاضرة والمستقبلية. (الأرشيف الوطني - قيام الاتحاد)

4. الإطار التشريعي للتدقيق في دولة الإمارات العربية المتحدة

4.1 التطور التاريخي للتدقيق في دولة الإمارات العربية المتحدة

اعتمد دستور دولة الإمارات العربية المتحدة الصادر في سنة 1971 وفي المادة 136 التي نصت على "تنشأ إدارة اتحادية مستقلة يرأسها مراجع عام يكون تعيينه بمرسوم، لمرجعة حسابات الاتحاد والأجهزة والهيئات التابعة له، وكذلك لمرجعة أيه حسابات أخرى يوكل إلى الإدارة المذكورة مراجعتها، طبقاً للقانون". ولذا تم إنشاء هذه الإدارة باسم ديوان المحاسبة وذلك بالقانون رقم (7) لسنة 1976 الذي كفل للديوان كل جوانب الاستقلال (العضوية والوظيفي والمالي). ويعمل الديوان على التأكد من أن الجهات الاتحادية تقوم بتحصيل المبالغ المالية بالطرق الصحيحة، وكذلك إنفاق الأموال العامة بطريقة حكيمة ورشيدة. كما يقوم الديوان كذلك بعمليات المراجعة والتدقيق للتأكد من تحقيق الهيئات الاتحادية لأهدافها المنشودة. (تاريخ ديوان المحاسبة). وبالتالي فإن ديوان المحاسبة هو الجهاز الأعلى للرقابة المالية والمحاسبة في دولة الإمارات العربية المتحدة وله شخصية اعتبارية علمية ويتمتع بالاستقلال المالي والإداري، وملحق بالمجلس الوطني الاتحادي. يتولى الديوان الرقابة على أموال الدولة وأموال الجهات الاتحادية والكشف عن الغش والفساد المالي. وبالرجوع إلى القانون الاتحادي رقم (7) لعام 1976 بإنشاء ديوان المحاسبة، نجد العديد من الجوانب الهامة في تحديد اختصاصات هذا الديوان ومنها:

مهمة ديوان المحاسبة هي الرقابة المالية على أموال الدولة، وللتحقق من سلامة ومشروعية إدارة هذه الأموال، ويقوم بعمله برقابة سابقة على الصرف خاصة للمشاريع وعقود التوريدات التي تزيد قيمتها على 500 ألف درهم. ورقابة لاحقة على الصرف (بعد الصرف) وهي التحقق من قيام الأجهزة الإدارية الحكومية بتحصيل الإيرادات، وأن النفقات صرفت بصورة ملائمة وفي حدود الموازنة، مراقبة جميع الحسابات خارج الميزانية مثل أمانات وسلف وحسابات جارية، مراقبة القروض، مراقبة استثمار الدولة، مراقبة حسابات المستودعات والمخازن، مراقبة تنفيذ المشروعات الإنمائية، فحص الحسابات الختامية للجهات الخاضعة لتدقيق ديوان المحاسبة، جرد النقود والطوابق والأوراق ذات القيمة. (القانون الاتحادي رقم 7. 1976).

وفي المادة رقم (11) من هذا القانون، يقوم الديوان في حدود اختصاصاته المنصوص عليها في هذا القانون بمهمتين رئيسيتين الأولى التي تهم بحثها هي: الكشف عن حوادث الاختلاس والإهمال والمخالفات المالية والتحقق فيها وبحثها ونواحي القصور في التشريع ونظام الرقابة الداخلية التي أدت إلى وقوعها واقتراح وسائل علاجها.

وديوان المحاسبة باعتباره إدارة اتحادية ملحقة بالمجلس الوطني الاتحادي، فإن نطاق عمله هو الوزارات والهيئات الاتحادية، من حيث التدقيق المحاسبي الخارجي، وأما الحكومات المحلية في الإمارات السبع فأغلبها لديها إدارات للتدقيق المحاسبي تحت مسميات متقاربة المعنى كإدارة الرقابة أو دائرة الرقابة،

كما صدر مؤخراً القانون الاتحادي رقم (8) لسنة 2011 _ بإعادة تنظيم ديوان المحاسبة _ ليحل محل القانون رقم (7) لسنة 1976 م المشار إليه. ويمارس الديوان عمله بناءً على هذا القانون. (ديوان المحاسبة. تاريخ ديوان المحاسبة).

في المخطط أدناه المنشور على صفحة ديوان المحاسبة، يتضح الإطار العام لعمل ديوان المحاسبة في الرقابة على الجهات الاتحادية:

الرسم البياني 1,1 : منهجية التدقيق في ديوان المحاسبة

كيف يؤدي ديوان المحاسبة مهامه الرقابية

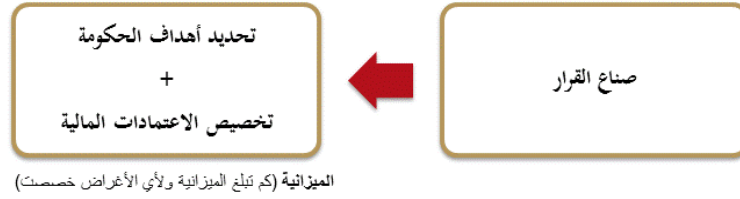

يهتم ديوان المحاسبة بالبحث في التساؤلات التالية والإجابة عليها:



منهجية ديوان المحاسبة في التدقيق

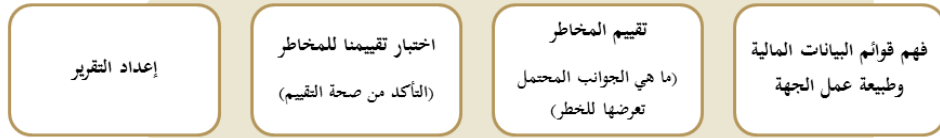

المصدر: ديوان المحاسبة: منهجية التدقيق في ديوان المحاسبة. 2019.

وبما أن كل إمارة من إمارات دولة الإمارات العربية المتحدة، لها حكومة محلية تتمتع باستقلالية في العديد من الجوانب الإدارية والمالية ولكن في ظل نظام الاتحاد. فنجد أن أغلب الإمارات لديها أنظمة وقوانين وتشريعات محلية ولكنها في الاجمال متوافقة مع النظام الاتحادي، يمكن توضيحها باختصار في الجدول التالي:

الجدول 1,1: الدوائر المختصة بالنظام المالي في الإمارات

م	الإمارة	الدوائر المختصة بالنظام المالي	الاختصاصات
1	ابوظبي	دائرة المالية	اسست دائرة المالية عام 1962، الاهداف الاستراتيجية: رفع كفاءة الإنفاق الحكومي، تنمية الإيرادات الحكومية، الحفاظ على مستويات معقولة من الدين العام، زيادة العائد على الاستثمارات العامة والحد من المخاطر المالية المتعلقة بها، تعزيز الملاءة المالية وزيادة حجم الاحتياطات المالية للحكومة.
		جهاز ابوظبي للمحاسبة	تم إنشاء "جهاز ابوظبي للمحاسبة" كهيئة مستقلة في عام 2008، واهدافها الاستراتيجية: التحقق من أن إدارة وتحصيل وصرف الأموال والموارد العامة تتم بكفاءة وفاعلية واقتصادية، التحقق من صحة التقارير المالية والتزام الجهات الخاضعة بالقوانين والأنظمة واللوائح وقواعد الحوكمة، الارتقاء بمبدأ المحاسبة والشفافية.
2	دبي	دائرة المالية	تم إنشاء دائرة المالية في حكومة دبي، وفقا للقانون رقم 5 لسنة 1995. وتتولى دائرة المالية مسؤولية الإشراف على جميع الشؤون المالية والمحاسبية لحكومة الإمارة، إضافة إلى إصدار الحسابات الختامية المجمعة لها. وتشمل مسؤوليات دائرة المالية وضع الموازنة السنوية العامة لحكومة دبي وتنفيذها بالتعاون مع جميع الجهات الحكومية المحلية، إضافة لقيامها بتقديم السيولة المالية، وتحويل الاعتمادات المالية إلى جميع الجهات الحكومية، كما

			تشرف على إعداد الموارد الحكومية واعتمادها وسبل تطويرها، بالتعاون مع الجهات الحكومية المعنية، كما تقوم دائرة المالية أيضاً بالتحقق من تحصيل الإيرادات العلمية، وتشرف على الحسابات المصرفية الخاصة بالحكومة.
	جهاز الرقابة المالية		تأسست وفقاً للقانون رقم (1) لسنة 1995، أهدافها: تعزيز وضمان المساءلة الفعالة وممارسات الإدارة السليمة، تأكيد استخدام الموارد الحكومية بكفاءة وفعالية واعتماد البنية والفطنة في القرارات الاستثمارية، خلق بيئة للرقابة وإدارة المخاطر تتميز بالشفافية والتطور، ضمان التقييم المستقل لتحقيق الأهداف الاستراتيجية لحكومة دبي.
3	دائرة المالية المركزية	الشارقة	تأسست في منتصف ستينيات القرن الماضي، مهامها إدارة الشؤون المالية والحسابات الحكومية في إمارة الشارقة باستخدام أفضل أنظمة الحسابات والموازنات الحكومية، لتعزيز كفاءة العمل الحكومي والأداء المالي في الإمارة، وتبني تجربة مميزة في مجال المالية العامة. لتحقيق الاستدامة المالية والازدهار الاقتصادي والاجتماعي، وتطوير إطار عام للسياسة المالية للإمارة لتعزيز النمو الاقتصادي المستدام، وتطوير كفاءة الإنفاق الحكومي، وتحسين مستوى الأداء المالي.
	دائرة الرقابة المالية		مرسوم أميري رقم (4) لسنة 1996 م بشأن إنشاء دائرة الرقابة المالية في إمارة الشارقة، اختصاصاتها التحقق من أن الأجهزة الإدارية قد قامت بتحصيل وتوريد الإيرادات المستحقة، التحقق من أن النفقات قد صرفت بصورة ملائمة وضمن الاعتمادات المقررة وطبقاً للقوانين واللوائح والتعليمات المنظمة، مراقبة حسابات التسوية، مراقبة الاستثمارات والتحقق من مدى سلامة أوجه الاستثمار ومدى مناسبة العائد، الكشف عن حوالت الاختلاس والإهمال والمخالفات المالية والتحقق فيها، دراسة أنظمة الرقابة الداخلية، دراسة القوانين والأنظمة واللوائح..
4	دائرة المالية	راس الخيمة	أهدافها الاستراتيجية: ضمان التميز في إدارة الموارد المالية بما يحقق استدامتها، تطوير وتعزيز نظم وسياسات مالية مبتكرة، التميز في تقديم الخدمات والارتقاء بتجربة المتعلمين، تعزيز العلاقات مع الشركاء والمجتمع، تطوير خدمات الدعم المؤسسي وتعزيز ثقافة الإبداع والابتكار المؤسسي
5	دائرة المالية	ام القيوين	تم إنشاء دائرة الشؤون المالية والإدارية بموجب مرسوم أميري رقم (5) لسنة 2005 الصادر بتاريخ 2006/8/9 والذي تم فيه تحديد الهيكل التنظيمي للدائرة وأقسامها واختصاصاتها، فهي تقوم بمهام الشؤون المالية والإدارية حيث استطاعت أن تعزز دورها في تطبيق القوانين والأنظمة المالية والإدارية واستكمال وحداتها الإدارية وإعداد النموذج والميزانيات السنوية.
	دائرة الرقابة المالية		أنشأت بالمرسوم الأميري رقم (6) لسنة 2006، لتمارس الدائرة في مجال الرقابة الاختصاصات التالية: تحصيل الإيرادات المستحقة للحكومة وتوريدها وإضافتها إلى الحسابات الخاصة بها، التحقق من النفقات، الرقابة على الأموال والموجودات المملوكة للحكومة
6	دائرة المالية	عجمان	تأسست دائرة المالية بعجمان سنة 2010م؛ بحيث تكون الدائرة هي الجهة المختصة مركزياً في حكومة الإمارة بتصريف كافة الشؤون المالية. وتتضمن اختصاصاتها إعداد مشروعات القوانين والمراسيم المحلية المتعلقة بالشؤون المالية التي ترى الدائرة ضرورة تطبيقها من قبل الدوائر الحكومية، والإشراف على تنفيذها، وإجراء المراجعة النورية لكافة التشريعات المحلية المتعلقة بالشؤون المالية المطبقة، ورفع التوصيات للجهات المعنية لتحديثها من وقت لآخر.
7	الدائرة المالية	الفجيرة	تم إنشاء الدائرة المالية وفقاً لاحتياجات العمل بحكومة الفجيرة في منتصف الستينيات، هدفها الاهتمام بكافة النواحي المالية الاقتصادية الخاصة بالإمارة، ومنها تمويل كافة المشروعات والتنمية الخاصة بحكومة الفجيرة ومتابعة كافة الاتفاقيات والعقود المختلفة والمنفذة عن طريق الدائرة

المصدر: البوابات الرسمية لحكومات الإمارات السبع 2019

ومع تعدد الأنظمة والتشريعات والقوانين في كل إمارة من الإمارات السبع في دولة الإمارات العربية المتحدة، مما يستلزم معه دراسة كافة تلك التشريعات والأنظمة والقوانين واستكشاف أوجه الاتفاق والاختلاف أو التفرّد، وبالتالي الحاجة إلى إجراء دراسة مقارنة شاملة لايسع الوقت لإنجازها، لذا سيقصر البحث المائل على دراسة العوامل المؤثرة في فاعلية التدقيق الداخلي في إمارة دبي.

4,2 ميثاق ومنهجية التدقيق الداخلي للحكومة الاتحادية لسنة 2019

اعتمدت الحكومة الاتحادية لدولة الإمارات بموجب قرار مجلس الوزراء رقم (3) لسنة 2019 دليل ميثاق ومنهجية التدقيق الداخلي للحكومة الاتحادية، على أن يعمل بهذا القرار من تاريخ صدوره والموافق 2019/01/6 ونشره في الجريدة الرسمية. وقرار مجلس الوزراء رقم (3) لسنة 2019 بشأن دليل ميثاق ومنهجية التدقيق الداخلي للحكومة الاتحادية، يوضح ميثاق التدقيق الداخلي ومهامه ورسالته وأهدافه، كما يحدد صلاحيات التدقيق الداخلي واستقلالته ونطاق عمله، بالإضافة إلى مهام ومسؤوليات وواجبات مكتب التدقيق الداخلي شاملاً لتبعيته الفنية والإدارية، وقواعد السلوك المهني اللازمة للمدققين الداخليين ومختلف القضايا المتعلقة بلجنة التدقيق والمخاطر. ويشرح القرار منهجية التدقيق الداخلي وأهدافها، وأطرها، وخطة التدقيق السنوية، ومختلف جوانب تنفيذ التدقيق الداخلي والمبادئ الأساسية للممارسة المهنية للتدقيق الداخلي. (وزارة المالية: 2019/3/5).

وأورد الميثاق تعريفاً للتدقيق الداخلي على أنه نشاط مستقل وموضوعي، يقدم تأكيدات وخدمات استشارية بهدف إضافة قيمة للجهة وتحسين عملياتها، حيث يساعد هذا النشاط في تحقيق أهداف الجهة الاتحادية من خلال اتباع أسلوب منهجي منظم لتقييم وتحسين فاعلية عمليات الحكومة وإدارة المخاطر والرقابة (دليل ميثاق ومنهجية التدقيق الداخلي. 2019)، وقد تم إعداد هذا الدليل بما يتوافق مع الإطار المهني الدولي للممارسة أعمال التدقيق الداخلي

والمعايير والإرشادات الدولية للممارسات المهنية للتحقيق الداخلي كما هي محددة من هيئات دولية مثل معهد المدققين الداخليين، مع مراعاة خصوصيات وبيئة العمل في الحكومة الاتحادية بدولة الإمارات العربية المتحدة. (المصدر السابق).

وتناول الميثاق مهمة التحقيق الداخلي وهي مماثلة لتعريف التحقيق الداخلي الوارد في الفقرات السابقة، ورسالة التحقيق الداخلي وأهدافه الرئيسية المتمثلة في تقديم تأكيدات للإدارة العليا بالجهة الاتحادية عن كفاءة وفعالية السياسات والإجراءات المتبعة لإدارة المخاطر الرئيسية، بالإضافة إلى تقييم كفاءة إدارة المخاطر، والصوابط الرقابية، وعمليات الحوكمة وتقديم التوصيات والاستشارات المستقلة لمساعدتها على الاضطلاع بواجباتها ومسؤولياتها. وأنه وفقاً للمعايير الدولية للتحقيق الداخلي معيار 1000 في شأن الأهداف، الصلاحيات والمسؤوليات فإنه يجب تحديد الهدف من التحقيق الداخلي قبل مباشرة عملية التحقيق وتماشياً مع المعيار رقم 2210 في شأن أهداف المهمة فإنه يتم تحديد الأهداف عن طريق: (1) إجراء تقييم أولي للمخاطر ذات العلاقة بالنشاط، (2) وضع احتمال وجود أخطاء جوهرية أو عمليات احتيال أو حالات عدم تقيد، (3) وجود مقاييس ملائمة لتقييم الحوكمة وإدارة المخاطر والصوابط الرقابية، ووجود مقاييس وضعتها الإدارة للتحقق من بلوغ الأهداف. (المصدر السابق).

وذكر الميثاق في فقرة استقلالية التحقيق الداخلي بأنه يتبين من خلال عدم الخضوع للضغوط والظروف التي تهدد قدرة نشاط التحقيق الداخلي أو مدير مكتب التحقيق الداخلي على القيام بمسؤولياته في التحقيق الداخلي على نحو غير متحيز، ومن خلال إمكانية الوصول المباشر إلى الإدارة العليا، ويمكن تحقيق الأمر من خلال الارتباط المزدوج بحيث تكون تبعية مكتب التحقيق الداخلي إدارياً لأعلى منصب إداري في الجهة الاتحادية "الإدارة العليا" والتبعية الفنية إلى لجنة التحقيق وذلك وفقاً للإطار الدولي للممارسات المهنية الخاصة بالتحقيق الداخلي. (المصدر السابق).

وفي شأن نطاق عمل التحقيق الداخلي، فيكون وفقاً للمعايير الدولية رقم 1000 في شأن الأهداف والصلاحيات والمسؤوليات، أن يشمل نطاق عمل التحقيق الداخلي على العديد من خدمات التأكيد، والخدمات الاستشارية، (1) أمثلة خدمات التأكيد: (أ) تنقيح الالتزام: من خلال مراجعة بعض الأنشطة المالية أو التشغيلية للجهة الاتحادية بغرض تحديد مدى توافقها مع شروط وقواعد وأنظمة محددة، وتأكيد كفاية وفعالية أنظمة الرقابة الداخلية، والتحقق من التزام الإدارات التي يتم التحقيق عليها بالمتطلبات التشريعية والقوانين ذات العلاقة. (ب) التحقيق التشغيلي "تقييم الأهداف": ويتم من خلال مراجعة منهجية الأنشطة التشغيلية لدى الجهة الاتحادية مقارنة بأهداف محددة ويعبر عنه بالتحقيق الإداري. (ج) تنقيح نظم تقنية المعلومات: وغرضه مراجعة مواطن القوة والضعف بالسياسات الحالية لهذه النظم ووسائل اخراج النتائج ويمكن الاستعانة بمتخصصين في هذا المجال عند الحاجة. (2) أمثلة خدمات الاستشارات: وهي تقديم المشورة والخدمات المتعلقة بها لإضافة قيمة لعمليات الجهة الاتحادية وتحسين إجراءات الحوكمة وإدارة المخاطر والرقابة وذلك دون أن تنطأ أي مسؤوليات إدارية أو تنفيذية بالمدقق الداخلي. (المصدر السابق).

وفي الباب الثاني تناول دليل الميثاق منهجية التحقيق الداخلي وهدفها إيجاد إطار تشغيلي موحد لأنشطة وعمليات التحقيق الداخلي في الحكومة الاتحادية من خلال توفير إرشادات للمعايير والسياسات والإجراءات التشغيلية التي يتوجب على المدققين الداخليين الالتزام بها أثناء تأديتهم وظائفهم وذلك بما يتفق مع الإطار المهني المعتمد لممارسة أعمال التحقيق الداخلي والتوجيهات والمعايير الصادرة عن معهد المدققين الداخليين. ويجدر الإشارة إلى أن الدليل يركز على القيمة المضافة من عملية التحقيق الداخلي، حيث حدد أن معيار نجاح نشاط التحقيق الداخلي في القيام بمهامه، هو مدى استفادة الإدارات الأخرى والأنشطة المدققة عليها من عملية التحقيق، وذلك عن طريق قياس القيمة التي ساهم التحقيق الداخلي في إضافتها للإدارة المدققة عليها، من خلال دراسة وفهم أسباب المشاكل والأخطاء والتركيز على كيفية العلاج الجذري لتلك المشاكل وعدم الاكتفاء برصدها. (المصدر السابق).

ويمكن تلخيص هذا الهدف الذي يمثل فاعلية نشاط التحقيق الداخلي في الشكل التالي:

الرسم البياني 1,2: فاعلية نشاط التحقيق الداخلي

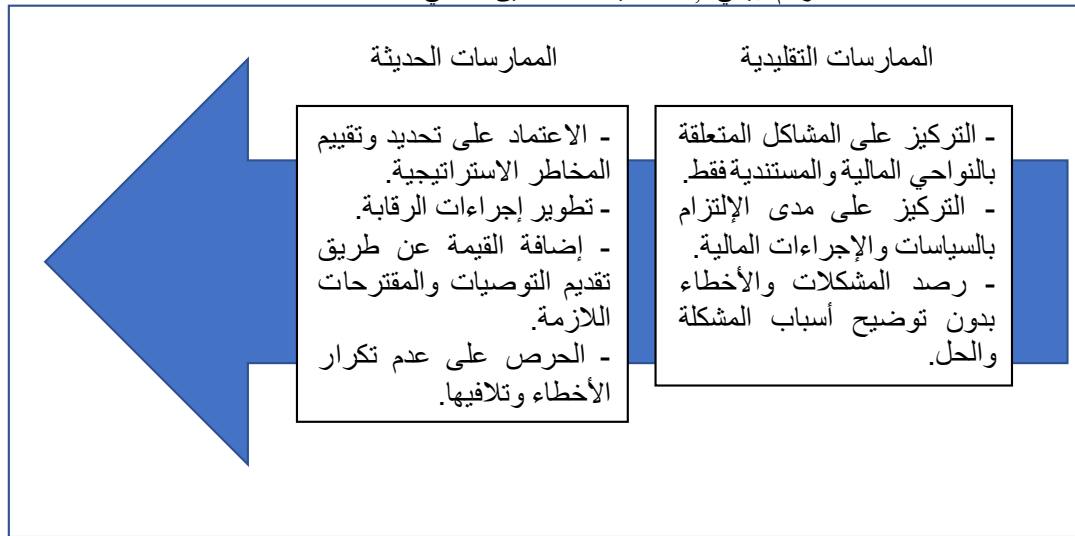

المصدر: دليل منهجية التحقيق الداخلي الحكومي 2019

وجاء في الدليل أنه وفقاً لأفضل الممارسات المهنية المتعارف عليها دولياً، فإن مهام التحقيق الداخلي يتم تنفيذها وفقاً للمراحل الموضحة أدناه:

المرحلة الأولى: التخطيط وتشمل: التحليل الاستراتيجي، تقييم المخاطر، وإعداد خطة التحقيق الاستراتيجية الشاملة.

المرحلة الثانية: التنفيذ وتشمل: تخطيط المهمة، العمل الميداني، إعداد وإصدار التقرير، والمراقبة والمتابعة

وتناول في الفقرة التالية شرحاً لجزء مهم من مرحلة تنفيذ مهام التحقيق الداخلي ألا وهي مرحلة إعداد وإصدار التقرير، حيث يتمثل الهدف الرئيس من عملية التقارير " وفقاً للمعايير الدولية للتحقيق الداخلي معيار رقم 2400 في شأن تبليغ النتائج"، "ومعيار التحقيق الداخلي رقم 2410 في شأن معايير التبليغ" في رفع نتائج التحقيق إلى المستويات الإدارية المناسبة القادرة على اتخاذ القرارات المتعلقة بمعالجة الملاحظات الناتجة عن أعمال التحقيق/ كما أنه الوسيلة المعتمدة الرئيسية لإضافة القيمة إلى الإدارات المدققة عليها، ويجب أن تكون تقارير التحقيق الداخلي موضوعية ودقيقة وواضحة ومختصرة وبناءة، وأن يتم الانتهاء منها في الوقت المناسب. (المصدر السابق).

وفي الباب الثالث من الدليل تم التركيز على موظفي التحقيق الداخلي، بدءاً من صفاتهم الشخصية التي يجب أن يتحلى بها المدقق الداخلي وهي:

- (1) الصدق والصراحة والاستقامة، واللباقة وقوة الملاحظة والتحلي بالمثابرة والتركيز على إنجاز الأعمال
- (2) المؤهل العلمي: شهادة بكالوريوس بحد أدنى
- (3) الخبرة العملية في مجال التحقيق الداخلي

(4) التدريب على التدقيق: أن يكون المدقق الداخلي قد أكمل برنامجاً تدريبياً كافياً في التدقيق الداخلي
(5) المعرفة والمهارات: ومنها أساسيات التدقيق وإجراءاته وفنونه، والمقدرة على التواصل مع الآخرين بمهنية وبكفاءة وطلاقة.
وكذلك ورد في الدليل مهام واختصاصات مدير مكتب التدقيق الداخلي، ومهام واختصاصات المنسق الداخلي الرئيسي، وكذلك المدقق الداخلي، وأبرز تلك المهام للمدققين الداخليين: المشاركة في إعداد الخطة الاستراتيجية والتشغيلية السنوية للتدقيق، وتنفيذ خطة التدقيق السنوية، تنفيذ أعمال التدقيق الداخلي والإشراف، إعداد تقارير التدقيق الداخلي، المساهمة في تطوير وتحديث سياسات وإجراءات التدقيق الداخلي، اقتراح نماذج العمل المطلوب العمل بها، توثيق العمل المنجز، توثيق وتأكيد الملاحظات التي تم اكتشافها ورد الإدارة عليها، إعداد قائمة التدقيق الداخلي الخاصة بأوجه القصور.

4.3 المبادئ الأساسية للممارسة المهنية للتدقيق الداخلي وردت في الدليل:

يجب على موظف التدقيق الداخلي العامل في الحكومة الاتحادية عند قيامه بأداء مهامه الالتزام بالمبادئ الأساسية للممارسة المهنية للتدقيق الداخلي المنصوص عليها في الإطار الدولي للممارسة المهنية لأعمال التدقيق الداخلي الصادر عن معهد التدقيق الداخلي وهي على النحو الآتي:

- أداء عمله بنزاهة.
- امتلاك الكفاءة اللازمة وبذل العناية المهنية اللازمة.
- الموضوعية والتحرر من أي تأثيرات على استقلاليتها "أي يكون مستقلاً".
- التوافق مع استراتيجيات وأهداف ومخاطر الجهة التي يعمل لديها.
- تناسب المركز الوظيفي مع المهام الموكولة له وامتلاك الموارد الكافية.
- الجودة والتحسين المستمر في أداء العمل.
- التواصل بشكل فعال باستخدام كافة قنوات التواصل المتاحة.
- تقديم تأكيد مرتكز على المخاطر.
- ذو بصيرة ومبادر، وذو نظرة مستقبلية.
- دعم تطوير وتحسين الجهة التي يعمل لديها.

5. التدقيق الداخلي في حكومة دبي

5.1 الإطار التنظيمي لوظيفة التدقيق الداخلي في الحكومة المحلية في إمارة دبي

في فترة التطور التاريخي للتدقيق في دولة الإمارات العربية المتحدة، سبق توضيح أن كل إمارة من إمارات دولة الإمارات العربية المتحدة، لها حكومة محلية تتمتع باستقلالية في العديد من الجوانب الإدارية والمالية ولكن في ظل نظام الاتحاد. ومنها إمارة دبي التي أنشأت دائرتين متخصصتين بالنظام المالي الحكومي، وهما: دائرة المالية: التي أنشأتها في عام 1995، وجهاز الرقابة المالية الذي أسسته في عام 1995 كذلك تحت اسم دائرة الرقابة المالية.

في الجانب التنظيمي لهاتين الدائرتين فقد صدر القانون رقم (7) لسنة 1995م بشأن النظام المالي للدوائر الحكومية في إمارة دبي، وصدر القانون رقم (1) لسنة 2016م بشأن النظام المالي لحكومة دبي في 7 مارس 2016 والمنشور في الجريدة الرسمية لحكومة دبي، العدد (397) – السنة (50) – 19 جمادى الآخرة 1437هـ – الموافق 28 مارس 2016، وهذا القانون حل محل القانون السابق رقم (7) لسنة 1995م بشأن النظام المالي للدوائر الحكومية في إمارة دبي.

ولغرض تسليط الضوء على أهمية هذا القانون في تنظيم العمل المالي في إمارة دبي، سيتم تناول الفقرات الواردة في القانون في حدود علاقتها المباشرة بمهام التدقيق في الجهات الحكومية.

عرف القانون رقم (1) لسنة 2016 الأموال العامة بأنها كافة الأصول المادية والمعنوية المملوكة للحكومة والجهات الحكومية، بما في ذلك الإيرادات العامة والتعويضات، ورؤوس الأموال المستثمرة في الشركات الحكومية، والأموال الحكومية المختلطة أو المسروقة أو المسددة بدون وجه حق، والنيون الحكومية المستحقة على الغير، والأموال المقدمة للحكومة كقرض أو مساعدات أو هبات أو تبرعات نقدية وعينية، وحصيلة مائتدوره الحكومة من أذونات الخزينة العامة وشهادات الاستثمار، والدعم المالي الذي تقدمه الحكومة للجهات والأفراد، وسائر الأموال الأخرى التي تنص التشريعات السلية على اعتبارها أموالاً عامة (النظام المالي للدوائر الحكومية في إمارة دبي).

وفي المادة رقم (3) جاءت أهداف القانون لتحقيق الشفافية والمساءلة والإدارة الرشيدة للمال العام، ومن خلال الإجراءات الرقابية التالية (المصدر السابق):

- الرقابة على الإيرادات العامة والنفقات العامة والأصول الحكومية والحسابات المختلفة لجميع الجهات الخاضعة لهذا القانون.
- اعتماد قواعد ومعايير الحوكمة للأداء المؤسسي السليم المستمد من أفضل الممارسات المطبقة في هذا الشأن.
- تحسين أنظمة درء وإدارة المخاطر المالية.

كما ورد في المادة رقم (6) بشأن التزامات الجهات الحكومية في إدارة الموارد الحكومية بفعالية وكفاءة واقتصاد، من خلال نظم للإدارة المالية والأداء والرقابة الداخلية المتوافقة مع القواعد والأنظمة التي تصدرها الدائرة في المسائل ذات الصلة بتطبيق هذا القانون. (المصدر السابق).

وفي شأن تنظيم عملية الرقابة في الجهات الحكومية، فقد خصص القانون المادة رقم (33) بشأن وحدات الرقابة المالية الداخلية، ونص المادة "تتشأ لدى الجهة الحكومية وحدة تنظيمية للرقابة المالية الداخلية، ترتبط مباشرة بمسؤول الجهة الحكومية، أو مجلس إدارتها حسب الأحوال، تناط بها مهمة التأكيد من صحة وسلامة تنفيذ الموازنة السنوية المعتمدة للجهة الحكومية، وتطبيق معاملاتها المالية، والتحقق من حسن إدارة المال العام، والمحافظة عليه، بما يتفق مع التشريعات السارية والقواعد المالية والمحاسبية المعتمدة من الدائرة في هذا الشأن، وإعداد التقارير اللازمة، ورفعها إلى السلطة التي ترتبط بها" (المصدر السابق).

وبالإطلاع على نص المادة رقم (33) يتبين عدة متطلبات شرعها القانون، وتتمحور حول التدقيق المحاسبي والمالي، وهي:

- إلزام الجهات الحكومية بإنشاء وحدة تنظيمية داخلية تعنى بنشاط الرقابة المالية الداخلية.
 - توفير الاستقلالية لوحدة الرقابة المالية الداخلية سواء بربطها بمسؤول الجهة الحكومية وهو أعلى سلطة تنفيذية فيها، أو مجلس إدارتها حسب كل حالة.
 - تتولى وحدة الرقابة المالية الداخلية مهام في صميم العمل المالي مثل التأكد من صحة وسلامة تنفيذ الموازنة السنوية التي اعتمدها الدائرة للجهة الحكومية، والتدقيق على المعاملات المالية، والتحقق من أن المال العام يتم إدارته بطريقة حسنة ويتم المحافظة عليه.
 - التقيد بالتشريعات والقواعد المالية والمحاسبية المعتمدة من الدائرة.
 - إعداد التقارير اللازمة ورفعها إلى السلطة التي ترتبط بها
- وقد أفرد القانون المادة رقم (43) بخصوص التقارير الدورية، وألزم الجهات الحكومية أن تقدم الدائرة تقارير مالية شهرية عن الإيرادات العامة والنقطة العامة في موعد لا يتجاوز نهاية الشهر الذي يلي الشهر المعني، وكذلك تقارير مالية ربع سنوية وفقاً للتبويب الذي تصدر به الموازنة العامة، على أن يتم اعتماد هذه التقارير من مسؤول الجهة الحكومية أو من يفوضه، ومدير التدقيق الداخلي ومدير الحسابات لديها أو من في حكمهما. (المصدر السابق).
- ويلاحظ هنا ورود صفة مدير التدقيق الداخلي باعتباره أحد المعنيين باعتماد التقارير المالية ربع السنوية، وهذه أول مرة يذكر هذا المنصب في القانون رقم (1) لسنة 2016.
- لقد جاءت المادة رقم (71) من القانون تحت بند الشفافية، لتلزم دائرة المالية في معرض تطبيقها لهذا القانون والقرارات الصادرة بموجبها، وفي إدارتها للمال العام وتنفيذ السياسة المالية للحكومة بمبادئ الشفافية، ويتحقق ذلك من خلال ما يلي (المصدر السابق).
- الإعلان عن أهداف السياسة المالية للحكومة.
 - نشر المؤشرات الرئيسية للموازنة العامة المعتمدة.
 - الإفصاح عن التغييرات في المعايير والسياسات المحاسبية المعتمدة.

5.2 الإطار التطبيقي لوظيفة التدقيق الداخلي في الحكومة المحلية في إمارة دبي

على الرغم من صدور القانون رقم (1) لسنة 2016 بشأن النظام المالي لحكومة دبي في 7 مارس 2016، إلا أن اللائحة التنفيذية له لم تصدر بعد، ولا يزال يُعمل باللائحة التنفيذية للقانون رقم (7) لسنة 1995م بشأن النظام المالي للدوائر الحكومية بإمارة دبي، والصادر بقرار رقم (37) لسنة 1996م. تأكيداً من المشرع على أهمية الدور الذي تلعبه الرقابة المالية في الجهات الحكومية، فقد خصصت المادة رقم (47) من اللائحة التنفيذية تحت عنوان " الرقابة على تنفيذ الميزانية"، حيث أخضعت جميع التصرفات ذات الأثر المالي في الدوائر الحكومية للرقابة المالية الداخلية، بهدف التأكد من مدى تطبيق الأنظمة والسياسات والتعليمات الصادرة والتأكد من مدى سلامة نظام الضبط الداخلي والإجراءات المطبقة وتحدد المهام الرقابية للمدققين الداخليين، وفقاً لما يرد في الهيكل التنظيمي والتوصيف الوظيفي وهذه اللائحة، ويراعى قيام وحدة الرقابة المالية الداخلية بالمهام الأساسية التالية: (اللائحة التنفيذية 1995):

- 1- التدقيق في الارتباطات المالية بهدف التحقق من توفر الاعتماد للنفقات المرتبطة بها.
- 2- التدقيق في مستندات الصرف قبل الأمر بصرفها وفي مستندات الفيد قبل تسجيلها في السجلات.
- 3- مراقبة الإيرادات والتحقق من قيدها في الحسابات الخاصة بها.
- 4- مراقبة حركة الأموال في المصارف والصناديق ومختلف أنواع السلف.
- 5- مراقبة المخازن وحركة المواد فيها، وإجراء الجرد المفاجئ لبعض الأصناف، ومتابعة جرد نهاية العام.
- 6- التحقيق في بيانات الحساب الختامي، والتحقق من صحة الأرقام الواردة فيه ومطابقتها لما ورد في السجلات والمستندات.
- 7- القيام بالتحقق المبني في المخالفات المالية المكتشفة من قبل الدائرة الحكومية بناء على طلب مدير عام تلك الدائرة وإحالة نتائج التحقيق إلى إدارة المراجعة المالية في ديوان سمو الحاكم.

وبالرجوع إلى المهام من 1 إلى 7، التي كُلفت بها وحدة الرقابة المالية، نجد أنه تقع في صميم العمل المحاسبي، ولم تطرق إلى أعمال التدقيق والرقابة الإدارية، بمعنى أن الأنشطة المطلوبة هي في مجال التدقيق الداخلي المحاسبي، ولكن نشاط وحدة الرقابة المالية يجب أن يتوسع ليشمل التحقق من كيفية صرف الموازنات وهل حققت الجهة الحكومية أهدافها التي بنت عليها موازنتها أساساً، حيث من المعلوم أن الجهات الحكومية تقدم موازنات البرمج والأداء وليس موازنة بنود الصرف والإيراد. ومن المؤمل أن يتم الانتباه لذلك في الإصدار الحديث من اللائحة التنفيذية.

ورد في المادة رقم (45) من اللائحة التنفيذية ما نصه "تعتبر وحدة الرقابة المالية الداخلية هي الجهة المسؤولة أمام إدارة المراجعة المالية بالتصديق مع الجهات التنفيذية الأخرى في الدوائر الحكومية، وهي التي تتابع الرد على ملاحظات إدارة المراجعة المالية وتقاريرها وتبليغها وتابعة استرداد المبالغ التي يطلب استردادها، دون إخلال بمسؤولية الموظفين المنفذين والإدارات الأخرى" (المصدر السابق).

ويلاحظ في المادة السابقة، الأهمية الكبيرة التي أولتها الحكومة المحلية لوحدة الرقابة الداخلية، ودورها حتى في مساءلتها جنباً إلى جنب مع الوحدات التنفيذية الأخرى في الجهة الحكومية، وألقى على عاتقها مسؤولية المتابعة والرد على ملاحظات إدارة المراجعة المالية "الخارجية" ومتابعة استرداد أموال الجهة الحكومية.

بتاريخ 25 يناير 2007 صدر القانون رقم (3) لسنة 2007 بإنشاء دائرة الرقابة المالية، والمنشور في الجريدة الرسمية، العدد (319) – السنة الأربعون – 2 ربيع الأول 1427هـ – الموافق 1 أبريل 2006م، وجاء في المادة رقم (3) من القانون أنه "تُشأ بموجب هذا القانون دائرة تسمى "دائرة الرقابة المالية" تتولى وفقاً للتشريعات السارية مهام الرقابة المالية على الجهات الخاضعة للرقابة من قبلها، وتلحق بالحاكم".

في المادة رقم (28) من القانون (3) لسنة 2007، تحل "دائرة الرقابة المالية" محل دائرة المراجعة المالية في كافة أعمالها واختصاصاتها.

وفي المادة رقم (7) من القانون رقم 3 لسنة 2007، أن تمارس دائرة الرقابة المالية مهام الرقابة على الجهات التالية: الدوائر الحكومية، المؤسسات والهيئات العامة التابعة للحكومة، الشركات التي تساهم الحكومة فيها بنسبة لا تقل عن 25% من رأسمالها أو التي تضمن لها الحكومة حداً أدنى من الربح، الجهات التي تقدم لها الحكومة إعانات مالية، أية جهة أخرى يعهد الحاكم أو رئيس المجلس التنفيذي إلى الدائرة بمراقبة حساباتها. (إنشاء دائرة الرقابة المالية 2007).

ونأتي على المهام التي حددها المشرع لدائرة الرقابة المالية، كما وردت في المادة رقم (8) من القانون رقم (3) لسنة 2007، وهي رقابة مالية ورقابة أداء كما يلي:

أولاً: الرقابة المالية: حيث تمارس الدائرة رقابة مالية لاحقة على العمليات المالية، بهدف التحقق من مدى مشروعية وملاءمة وصحة احتساب تلك العمليات.

ثانياً: رقابة الأداء: وذلك للتحقق من مدى الكفاءة والفعالية والاقتصاد في تنفيذ المهام والأنشطة. وفي المادة رقم (15) من القانون رقم (3) لسنة 2007، أُلزم المشرع جميع الجهات الخاضعة للرقابة والتي تقتضي طبيعة عملها وأنظمتها الداخلية تعيين مدقق حسابات خارجي، إطلاع الدائرة على طريقة تعيين هؤلاء المدققين ونطاق عملهم وتقاريرهم، والتحقق من مدى تنفيذهم لالتزاماتهم ومراعاتهم للأنظمة والقوانين النافذة والمعايير الدولية للمراجعة، ومعايير المحاسبة الدولية (المصدر السابق).

ولغرض الحفاظ على المال العام، جاءت المادة رقم (19) لتفصل الحالات والوقائع التي تعتبر مخالفات مالية تستوجب التحقيق فيها، سواء كان اكتشافها من قبل دائرة الرقابة المالية أو الجهة الخاضعة للرقابة (المصدر السابق):

- 1- مخالفة القواعد والأحكام المالية والأنظمة واللوائح المعمول بها في الجهة الخاضعة للرقابة.
- 2- مخالفة القواعد والأحكام المتعلقة بتنفيذ الموازنة العامة أو الموازنات الخصة بالجهات الخاضعة للرقابة.
- 3- مخالفة القواعد والأحكام المنظمة للعقود والاتفاقيات التي تجريها الجهات الخاضعة للرقابة ومخالفة القرارات الإدارية ذات الأثر المالي، والقواعد والأحكام المنظمة للمستودعات والتعاميم المالية والمحاسبية الصادرة عن الجهات المختصة.
- 4- كل تصرف أو إهمال أو تقصير يترتب عليه صرف مبالغ غير وجه حق من الأموال الخاضعة للرقابة أو ضياع حق من الحقوق المالية للحكومة أو إحدى الجهات الخاضعة لرقابة دائرة الرقابة المالية، أو المساس بمصلحة هذه الجهات المالية أو إلحاق الضرر بها.
- 5- اختلاس الأموال التي تشملها الرقابة، أو إساءة الائتمان أو التحايل بقصد الاختلاس أو السرقة أو الإهدار.
- 6- عدم موافاة دائرة الرقابة المالية بالحسابات والبيانات المالية الختامية والمستندات المؤيدة لها في المواعيد المحددة، أو بما تطلبه الدائرة من أوراق أو وثائق أو غيرها لازمة للقيام بأعمال الرقابة.
- 7- عدم الرد على ملاحظات الدائرة أو مراسلاتها بصفة عامة، أو التأخر في الرد عليها بغير عذر مقبول، وتعتبر عدم الإجابة على استيضاح أو ملاحظة الدائرة لمدة تجاوز ثلاثين يوماً في حكم عدم الرد.

وجدير بالذكر أن إمارة دبي سعت إلى تطوير إجراءات الرقابة المالية في الإمارة من خلال تحديث قوانينها وتشريعاتها المنظمة، ومنها إصدار القانون رقم (4) لسنة 2018 بإنشاء جهاز الرقابة المالية، وقد جاء في مادة التعريف، أن أنظمة الرقابة: هي الأنظمة المالية والمحاسبية والإدارية والتشغيلية والذكية لدى الجهات الخاضعة " للجهات التي تخضع لرقابة الجهاز وفق هذا القانون ". (إنشاء جهاز الرقابة المالية 2018).

وفي المادة رقم (46) من القانون " يخل هذا القانون محل القانون رقم (8) لسنة 2010 وتعديلاته المشار إليه. وفي المادة رقم (5) من القانون، تم بيان الهدف من إنشاء الجهاز، والتي تتلخص في (المصدر السابق: ص 2-3):

- 1- الرقابة على المال العام، من خلال التحقق من مشروعية وحسن التصرف في استخدامه وإدارته.
- 2- التحقق من أن تنفيذ المهام والأنشطة المالية والإدارية والمحاسبية والتشغيلية والذكية في الجهات الخاضعة، يتم بكفاءة وفعالية.
- 3- تعزيز وضمان المساءلة الفعالة وممارسات الإدارة السليمة لدى الجهات الخاضعة.
- 4- المساهمة في خلق بيئة محفزة للرقابة وإدارة المخاطر، تتميز بالشفافية والنزاهة.
- 5- التنبؤ من أن القرارات والإجراءات الإدارية في الجهات الخاضعة تتم وفقاً للتشريعات المعمول بها في الإمارة.
- 6- تعزيز مبدأ الشفافية والنزاهة ومكافحة الفساد المالي والإداري بشتى صورته ومظاهره وأساليبه.

تشمل أعمال الرقابة التي يمارسها الجهاز على الجهات الخاضعة، ما يلي (المصدر السابق):

- 1- الرقابة المالية والالتزام
- 2- رقابة الأداء.
- 3- الرقابة على أنظمة الرقابة.
- 4- الرقابة على كفاءة وفعالية أنظمة الرقابة.

وجاءت المادة رقم (16) لتوضح المهمة الرابعة المتمثلة في الرقابة على كفاءة وفعالية أنظمة الرقابة التي يمارسها جهاز الرقابة من خلال:

- 1- فحص مختلف أنظمة الرقابة وإجراءاتها للتحقق من مدى سلامتها، وتحديد أوجه القصور فيها، والتوصية بما يجب اتخاذه لمعالجتها.
- 2- تقييم مدى تطبيق مبادئ الحوكمة وإدارة المخاطر المؤسسية، وإدارة الأداء، ونظام الرقابة الداخلية، و وحدات التدقيق الداخلي، وغيرها لدى الجهات الخاضعة، وفقاً لأفضل الممارسات العالمية، لتحديد المعوقات التي تواجهها، وتحديد فرص التحسين والتطوير.

إجراء عملية التدقيق - المادة رقم (18) - (المصدر السابق):

1- للجهاز التدقيق في أي حسابات أو مستندات أو سجلات أو أوراق يرى أنها لازمة لقيامه بأعمال الرقابة على الوجه الأكمل، ويجوز إجراء عملية التدقيق إما في مقر الجهاز أو في مقر الجهة الخاضعة أو في مقر الجهة التي توجد لديها الحسابات والسجلات والأوراق والمستندات الخاضعة للتدقيق.

2- للجهاز طلب ربط أنظمة الرقابة المعمول بها لدى الجهات الخاضعة بالجهاز لإجراء عملية التدقيق وتحليل بيانات العمليات المالية والتشغيلية عن بُعد.

3- تُعتبر كافة المعلومات والبيانات والوثائق التي يطلع عليها موظفوا الجهاز أثناء قيامهم بعملية التدقيق سرية، سواء تم الاطلاع عليها في مقر الجهاز أو في مقر الجهة الخاضعة أو في مقر الجهة التي توجد لديها الحسابات والسجلات والأوراق والمستندات الخاضعة للتدقيق.

وبشأن وحدات التدقيق الداخلي فقد قررت المادة رقم (22)، أن للجهاز حق الاطلاع على خطط وسير عمليات وحدات التدقيق الداخلي في الجهات الخاضعة، وخطط وسير عمليات المدققين الخارجيين، وعلى التقارير الصادرة عنها وابداء الرأي فيها، والتحقق من مدى تنفيذ الجهات الخاضعة للتوصيات الواردة فيها.

وتعرضت المادة رقم (26) إلى واجبات الجهات الخاضعة، وما الذي يجب عليها الالتزام به وأهمها:

- السماح لموظفي الجهاز بفحص وتقييم أنظمة الرقابة وفقاً لأحكام هذا القانون والتشريعات السارية.
- إخطار الجهاز بأي مخالفة مالية وإدارية تُرتكب فيها.
- إنشاء وحدات تنظيمية للرقابة الداخلية.

6. النتائج والتوصيات

6,1 توصيل البحث إلى نتائج أهمها ما يلي:

1. بادرت حكومة دولة الإمارات الاتحادية والحكومات المحلية إلى تشريع قوانين للرقابة والتدقيق الداخلي للجهات والوحدات الحكومية من وقت مبكر من قيام الدولة الاتحادية.
2. تم إنشاء عدة أجهزة ودوائر للرقابة المالية والإدارية في دولة الإمارات، أهمها ديوان المحاسبة الاتحادية عام 1976، جهاز أبوظبي للمحاسبة، جهاز الرقابة المالية دبي، دائرة المالية المركزية الشارقة، دائرة المالية رأس الخيمة، دائرة الرقابة المالية أم القيوين، دائرة المالية عجمان، الدائرة المالية الفجيرة.
3. إن أغلب الإمارات لديها أنظمة وقوانين وتشريعات محلية ولكنها في الاجمال متوافقة مع النظام الاتحادي
4. اعتمدت الحكومة الاتحادية لدولة الإمارات سنة 2019 دليل ميثاق ومنهجية التدقيق الداخلي للحكومة الاتحادية وهذا الدليل يتوافق مع الإطار المهني الدولي للممارسة أعمال التدقيق الداخلي والمعايير والإرشادات الدولية للممارسات المهنية للتدقيق الداخلي كما هي محددة من هيئات دولية مثل معهد المدققين الداخليين.

6,2 يوصي البحث بما يلي:

1. أن تحذوا الإمارات الباقية حذوا حكومة أبوظبي وحكومة دبي في إنشاء جهاز للرقابة المالية، تكون من بين مهامه الإشراف على مهام وحدات التدقيق الداخلي في الجهات الحكومية وشبه الحكومية.
2. الاستمرار في متابعة المعايير والإرشادات الدولية للممارسات المهنية للتدقيق الداخلي وموائمتها مع التشريعات الاتحادية والمحلية.
3. العمل على تعزيز استقلالية وحدات التدقيق الداخلي في الجهات الحكومية، لتعزيز فاعلية أنشطة وتقارير التدقيق الداخلي.
4. الاعتماد على أساليب متطورة وحديثة في تنفيذ أنشطة وحدات التدقيق الداخلي، وإن أمكن الاستفادة من التطورات الحاصلة في الذكاء الاصطناعي.

7. مصادر ومراجع البحث

7,1 قائمة المصادر

1. الإمارات . 1971 . دستور دولة الإمارات العربية المتحدة . "بشأن إنشاء ادارة اتحادية مستقلة لمراجعة حسابات الاتحاد والاجهزة والهيئات التابعة له" . الجريدة الرسمية . المادة 136
2. الإمارات . ابوظبي . 1976 . مرسوم بقانون إتحادي رقم (7) لسنة 1976 . "في شأن إنشاء ديوان المحاسبة" . صادر عن قصر الرئاسة . الجريدة الرسمية . 1976/11/6
3. الإمارات . 2011 . مرسوم بقانون إتحادي رقم (8) لسنة 2011 . "في شأن إعادة تنظيم ديوان المحاسبة" . الجريدة الرسمية
4. الإمارات . 2019 . قرار مجلس الوزراء رقم 3 لسنة 2019 . "بشأن اعتماد دليل ميثاق ومنهجية التدقيق الداخلي للحكومة الاتحادية" . الجريدة الرسمية
5. الإمارات . دبي . 1995 . القانون رقم (7) لسنة 1995 م . "بشأن النظام المالي للوحدات الحكومية في إمارة دبي" . الجريدة الرسمية <https://www.mof.gov.ae/ar/lawsAndPolitics/>
6. الإمارات . دبي . 2016 . القانون رقم (1) لسنة 2016 . "بشأن النظام المالي لحكومة دبي" . الجريدة الرسمية . العدد (397) . السنة (50) . 19 جمادى الآخرة 1437 هـ . الموافق 28 مارس 2016
7. الإمارات . دبي . 2007 . القانون رقم (3) لسنة 2007 . "بشأن دائرة الرقابة المالية" . الجريدة الرسمية . العدد (319) . السنة الأربعون . 2 ربيع الأول 1427 هـ . 1 أبريل 2006م .
8. الإمارات . دبي . 2018 . "قانون رقم 4 لسنة 2018 . "بشأن جهاز الرقابة المالية" . الفصل الثالث: أهداف الجهاز . الجريدة الرسمية . العدد 431 . المادة 5
9. الإمارات . دبي . 2009 . "قانون رقم 24 لسنة 2009 بشأن إنشاء صندوق دبي لدعم المالي . الجريدة الرسمية . العدد 343 . المادة 5 .
10. حكومة دبي . البوابة الرسمية . 2018 . الجهات الحكومية <http://www.dubai.ae/ar/government/pages/default.aspx?category=Government>
11. معهد المدققين الداخليين . 2017 . المعايير الدولية للممارسة المهنية للتدقيق الداخلي .

7,2 قائمة المراجع:

1. الأرشيف الوطني - تيمم الاتحاد . 4/3/2019 . <https://www.na.ae/ar/archives/historicalperiods/union.aspx>
2. الأمانة العامة للمجلس التنفيذي . حكومة أبوظبي . الجهات الحكومية . . <https://www.ecouncil.ae/ar/ADGovernment/Pages/GovernmentEntities.aspx> . 43/2019
3. البوابة الرسمية لحكومة الفجيرة . دوائر حكومية الخيمة . الجهات الحكومية . 4/3/2019 . <http://www.fujairah.ae/ar/Pages/default.aspx>
4. البوابة الرسمية لحكومة دبي . الجهات الحكومية . 4/3/2019 . <http://www.dubai.ae/ar/Pages/default.aspx>
5. البوابة الرسمية لحكومة رأس . الدوائر الحكومية . 4/3/2019 . <https://www.rak.ae/wps/portal/rak/government-entities/>
6. البوابة الرسمية لدولة الإمارات - تأسيس دولة الإمارات . 4/3/2019 . <https://www.government.ae/ar-AE/more/history-of-the-uae>
7. المؤسسة العامة للتعليم الفني والتدريب المهني . د.ت . مراجعة ومراقبة داخلية . المملكة العربية السعودية
8. بوابة حكومة الشارقة الإلكترونية . دوائر حكومة الشارقة . 4/3/2019 . https://www.sharjah.ae/index_ar.aspx
9. بوابة حكومة أم القيوين . الدوائر الحكومية . 4/3/2019 . <https://www.uaq.ae/ar/home.html>
10. حكومة عجمان . الجهات الحكومية . 4/3/2019 . <https://www.ajman.ae/>
11. ديوان المحاسبة . تاريخ ديوان المحاسبة . 4/3/2019 . <http://www.sai.gov.ae/ar/>
12. شحته . حسين حسين . د.ت . أصول المراجعة والرقابة مع إطلالة إسلامية . كلية التجارة جامعة الأزهر
13. موسوعة الامارات . 4/3/2019 . <http://uaepedia.ae/index.php>
14. نور الدين . أحمد فايد . 2015 . التدقيق المحاسبي وفقاً للمعايير الدولية . دار الجنان للنشر والتوزيع . الطبعة الأولى . الأردن . سينسر . 2010 . كتاب التدقيق الداخلي . مطبعة أنطوني روي . المملكة المتحدة .

USING THE ZAKAT FUND IN STRUCTURING ISLAMIC MICRO TAKAFUL MODEL AS AN ALTERNATIVE FOR THE EXISTING MODELS

توظيف صندوق الزكاة في هيكلة التأمين التكافلي المصغر بديلا عن الهياكل الموجودة

Habeebullah Zakariyah^a & Ahmad Abdulla O M Al-Own^b

^aIUM Institute of Islamic Banking and Finance International Islamic University Malaysia

^bQatar University -Qatar

ملخص البحث:

يعد التأمين التكافلي (التكافل) أحد المنتجات المصرفية الإسلامية الرائدة في الأونة الأخيرة، حيث لقي هذا المنتج قبولا واسعا في المؤسسات الإسلامية. يسعى هذا البحث إلى مناقشة الإشكاليات الموجهة ضد التأمين التكافلي الإسلامي؛ ذهب العلماء المعاصرون إلى تكييف التأمين التكافلي على أنه من عقود التبرعات، وبناء على هذا التكييف الفقهي فقد وجهت ضده إشكاليات شرعية، منها: أولا: الائتزام بالتعويض من قبل الصندوق: الشرط المنصوص عليه في العقد، بدفع العوض حالة الضرر، الأمر الذي يجعل العقد يأخذ صفة "التزام بالتبرع مقابل التزام بالعوض"، وبذلك يصبح العقد معاوضة، يجري فيه ما يجري في عقود المعاوضات من الغرر وغيره. وثانيا: الفائض التأميني الذي يصرف على المؤمنين "حملة الوثائق" دون غيرهم، بموجب عقد الوكالة بالاستثمار، فإذا كان العقد من عقود التبرع، لماذا يصرف الفائض التأميني لمصلحة حملة الوثائق. وهاتان الإشكاليتان تجعلان التأمين التكافلي الإسلامي أقرب إلى التأمين التقليدي من الإسلامي، وبناء على ما سبق، حاول البحث تقديم مقترح جديد يختص بالتأمين التكافلي المصغر، لمواجهة التحديات السالفة، يتم إنشاء هذا الصندوق التكافلي من أموال الزكاة، ويمكن الأخذ من مصرف الفقراء والمساكين والغارمين وفي سبيل الله، خروجاً من قضية اشتراط التملك في بعض مصارف الزكاة، بحيث يتم تغطية المخاطر والأضرار الواقعة على حملة الوثائق. وتتبنى هذه الدراسة على مبدئين شرعيين: الأول: مبدأ التكافل وجواز منح الفقراء والمساكين من الزكاة، الثاني: إمكانية الأخذ من صندوق الزكاة لإنشاء صندوق التكافل. وانتهجت هذه الدراسة المنهج الاستقرائي والمنهج التحليلي النقدي وذلك في تتبع هياكل التأمين التكافلي، ومدى إمكانية الاستفادة من صندوق الزكاة لبناء هيكل التكافل. وخلصت الدراسة إلى أنه لا مانع شرعا من استخدام صندوق الزكاة للتأمين التكافلي، وخروجاً من مشكلة التملك، يمكن الصيرورة إلى التملك الجماعي دون الفردي؛ وذلك بقطع الملكية من المزكي. ويوصي البحث الهيئات والمؤسسات المختصة بوضع إطار يمكن من خلاله تطبيق هذا الهيكل في الوقع المعاصر.

الكلمات المفتاحية: التأمين التكافلي- الزكاة- هياكل التكافل.

Abstract

Takaful is considered as one of the leading sector in Islamic financial institution in the recent times as it has received wide acceptance among Islamic financial institutions. This paper addresses the *shariah* issues related to Takaful industry. Muslim jurists argue that Takaful is under *Tabaru`* contract, this pave the way for many *shariah* issues in the contract. First: Obligation to compensate from takaful fund: The condition stipulated in the contract to pay a compensation due in case of damage or hazard, which causes the contract to have the characteristic of "an obligation to donate in exchange for an obligation to compensate". Hence, the contract becomes bilateral (*mu`awadhah*). Second: The insurance surplus, which is returned to the policy holders only. These two issues draw Takaful closer to the conventional insurance than the Islamic one. This paper attempt to introduce a new model for micro-takaful, in order to circumvent the above challenges. This model is based on a portion of zakat fund allocated for takaful which can also be taken from the portion of Asnaf such as: poor and needy, *Fisabilillah* as a departure from the issue of ownership requirement in some of the Zakat disbursements "*Tamluk*". This study adopts two legal principles, the first of which is the principle of Takaful and the permissibility of giving the poor and needy from zakat fund. The second: the possibility of taking from the Zakat Fund to establish the Takaful fund. This study adopted both the inductive approach and the critical analytical approach in tracking takaful models, and the extent to which the Zakat Fund can be used to create takaful fund. The study concluded that there is no legal objection to the use of the Zakat Fund for Takaful and that it can become public ownership rather than individual. The research recommends the relevant authorities and institutions to set a framework within which this structure can be applied in contemporary reality.

Keyword: Takaful-Zakat-Takaful models

التعريف بالتأمين التكافلي

للتأمين الإسلامي مسميات كثيرة حسب المناطق والأماكن، فيسمى بـ "التأمين التكافلي" في بعض الدول الإسلامية " كما يسمى بالتأمين التبادلي، ويصلح عليه بعض الباحثين بأنه "التأمين الإسلامي"، ويطلق على التأمين الإسلامي "التكافل" في بعض الدول مثل ماليزيا وغيرها. وقد عرّف هذا النوع من التأمين بتعريفات كثيرة، وإن كان بعضها متقاربة من حيث المضمون والمحتوى. ويمكن أن نلخص هذه التعريفات في الآتي:

عرفه الغفيلي (نوازل الزكاة، 2008، ص: 258) بقوله "اكتتاب مجموعة من الأشخاص يتهدهم خطر واحد بمبالغ نقدية على سبيل الاشتراك، يعطى منها تعويض لكل من يتعرض للضرر من هؤلاء" وذهب محمد التويجري إلى التأمين الإسلامي (موسوعة الفقه الإسلامي، ج3، ص 446) هو: "أن تتفق مجموعة من الأقارب، أو الأصدقاء، أو الزملاء على أن يدفع كل منهم اشتراكاً معيناً، لتعويض الأضرار التي قد تصيب أحدهم إذا تعرض لخطر معين من مرض، أو خسارة، أو احتراق"، ويقاربه تعريف الزحيلي (الفقه الإسلامي وأدلته للزحيلي، ج5، ص3415) إذ يرى أن التأمين الإسلامي هو "أن يتفق عدة أشخاص على أن يدفع كل منهم اشتراكاً معيناً، لتعويض الأضرار التي قد تصيب أحدهم إذا تحقق خطر معين". وعرّفه القرّة داغي بأنه " اتفاق بين شركة التأمين الإسلامي باعتبارها ممثلة لهيئة المشتركين (حساب التأمين أو صندوق التأمين) وبين الراغبين في التأمين (شخص طبيعي أو قانوني) على قبوله عضواً في هيئة المشتركين والتزامه بدفع مبلغ معلوم (القسط) على سبيل التبرع به وبعودته لصالح حساب التأمين على أن يدفع له عند وقوع الخطر- تعويضاً- طبقاً لوثيقة التأمين والأسس الفنية والنظام الأساس للشركة" (القرّة داغي، 2006، التأمين الإسلامي، ص 203).

و عرف القانون الماليزي التكافل (الفصل الأول، 2013م، ص 48) بأنه "اتفاقية تقوم على المساعدة المشتركة، يوافق بموجبها المشاركون في التكافل على المساهمة في صندوق مشترك لتقديم منافع مالية مشتركة تنفع للمشاركين في التكافل أو المستفيدين منه عند وقوع أحداث متفق عليها مسبقاً" في حين نجد هيئة المحاسبة والمراجعة للمؤسسات المالية الإسلامية يعرف التأمين الإسلامي بأنه: "اتفاق أشخاص يتعرضون لأخطار معينة على تلافي الأضرار الناشئة عن هذه الأخطار، وذلك بدفع اشتراكات على أساس الالتزام بالتبرع" (هيئة المحاسبة والمراجعة للمؤسسات المالية الإسلامية، المعايير الشرعية، 2017م، ص686).

ويتفق أكثر مضمون ما سبق من التعريفات مع ما ذهب إليه مجمع الفقه الإسلامي الدولي في المادة الأولى حيث وضع الأحكام والضوابط الشرعية لأسس التأمين التعاوني، فعرف التأمين الإسلامي (قرار بشأن الأحكام والضوابط الشرعية لأسس 1435 هـ، الموافق / 2013م) بأنه: "التأمين التعاوني: هو اشتراك مجموعة أشخاص يتعرضون لخطر أو أخطار معينة على أن يدفع كل منهم مبلغاً معيناً على سبيل التعاون لصندوق غير هادف للربح؛ لتعويض الأضرار التي قد تصيب أيّاً منهم إذا تحقق الخطر المعين، وفقاً للعقود المبرمة والتشريعات المنظمة".

إلا أن اللافت للنظر أن قرار المجمع لم يذكر مصطلح "الالتزام بالتبرع" و سنوضح الإشكالية الواردة في هذا المصطلح عند الحديث عن الإشكاليات الواردة على الهياكل المستخدمة في صناعة التكافل.

الحكم الشرعي للتأمين التكافلي:

اختلف الفقهاء المعاصرون في الحكم على التأمين التعاوني الإسلامي قبولاً ورفضاً، وذلك طبقاً للتكييف أو البناء الفقهي لكل من هؤلاء الفقهاء له، فذهب بعضهم أن التأمين التعاوني لا يختلف عن التأمين التجاري المحرم (سليمان الثنيان، 1993م). التأمين وأحكامه، ص 284؛ أبو عمرو ديبان بن محمد الديباني، (1423هـ). المعاملات المالية معاصرة وأصالة، ج4، ص 160)، لأن تسمية هذا العقد تعاونياً لا يخرج منه كونه شبيهاً للتأمين التقليدي التجاري المحرم، بل إن سبب تحريم التأمين التجاري موجود في التأمين التكافلي أيضاً، بما في ذلك الغرر لأن العقد الذي بني عليه التأمين التكافلي عقد معاوضة وليس التبرع كما زعم المؤيدون للتأمين التكافلي.

هذا ونجد أن غالبية العلماء والفقهاء المعاصرين ذهبوا إلى جواز ه بدليل أن العقد مبني على التبرع لا المعاوضة، وبهذا فلا يضر فيه الغرر الذي يفسد العقد (الضريبر، 1990 الغرر وأثره في العقود، ص 653)، وانظر (عيسى زكي شقره، 2016، قصد الاسترباح في عقود التأمين التكافلي، المجلد: 31 العدد: 104، ص 542) سنتدين إلى أن الهدف منه التقليل من حدة المخاطر والخسائر التي تصيب أحد الأعضاء المشاركين بخلاف التأمين التجاري الذي يسعى إلى تحقيق أكبر قدر من الربح. يضاف إلى ذلك أن حاجة الناس إلى التأمين ماسة، ومع كثرة مطالب الحياة ومتاعبها، وكثرة الحوادث والمخاطر التي يتكبدها الفرد يومياً يجعل حاجة الناس إلى التأمين أو النظام الذي يضمن للفرد الأمن والطمأنينة أمس في وقتنا الحاضر.

وقد نادى الضريبر (الضريبر، 1990 الغرر وأثره في العقود، ص 663) إلى "أن تتولى الحكومات في البلاد الإسلامية أمر التأمين بكافة أنواعه، فتجعل له منظمة خاصة تشرف عليه، على أن يكون المعنى التعاوني بارزاً فيه بروجاً واضحاً، وذلك بالنص صراحة في عقد التأمين، على أن المبالغ التي يدفعها المشترك تكون تبرعاً مئة للشركة، بعان منها من يحتاج إلى المعونة من المشتركين حسب النظام المتفق عليه".

2: التكييف الفقهي للتأمين التعاوني/ التكافلي:

هناك عدة تكيفات فقهية للتأمين الإسلامي، وهذا نتيجة تحريم التأمين التجاري التقليدي، بسبب ما فيه من الغرر من جانب، بالإضافة إلى دخوله في المحاذير الشرعية.

وقد تم التكيف الفقهي للتأمين الإسلامي على مبدأ الالتزام بالتبرع من المشاركين أو المساهمين عند كثير من الباحثين المعاصرين (مجلس الخدمات المالية الإسلامية، معيار المبادئ الإرشادية لضوابط التأمين التكافلي، 2009م، ص2)، وانظر: (هيئة المحاسبة والمراجعة للمؤسسات المالية الإسلامية، المعايير الشرعية، 2017م، ص686). بحيث ترجع هذه المساهمة لمصلحة وحماية من وقع في الضرر من هؤلاء المشتركين، ويكون هؤلاء المشتركين صندوقاً يسمى بـ "صندوق التأمين" ويكون لهذا الصندوق شخصية اعتبارية. وبعد ذلك يختار هذا الصندوق شخصاً سواء كان من المشتركين أو شخصية اعتبارية أخرى مرخصة له بأن يدير هذا الصندوق نيابة عن المشتركين على أساس الوكالة بالأجرة أو على أساس المضارب. ويقوم هذا الأخير بموجب العقد بينه وبين الصندوق باستثمار الأموال لمصلحة المشتركين.

وجدير بالذكر أن الشركة أو الشخصية الاعتبارية المخولة بالاستثمار تتحمل كل المصروفات الخاصة بهذه المهمة، في حين يتحمل الصندوق أجرة الوكالة لصالح الوكيل "الشخصية الاعتبارية" أما إذا كان العقد بين الصندوق وبين من يدير الصندوق عقد مضاربة، فإن المضارب في هذه الحالة يأخذ نسبة من الربح حسب الاتفاق، وفي حالة الخسارة فإن رب المال "الصندوق" هو الذي يتحمل الخسارة على ما هو معلوم في عقد المضاربة. (المعيار الشرعي، (13)، هيئة المحاسبة والمراجعة، ص369).

ويلاحظ أن التأمين الإسلامي المبني على أساس التبرع، ولن يعتريه الغرر في تطبيقه إلا أن هذا النوع من الغرر معتبر فيه. لأنه يعتق في التبرعات ما لا يعتق في المعاوضات. (القره داغي، 2006؛ والضربير، 1990م).

وعليه يمكن القول بأن التأمين الإسلامي مبني على التعاون بين المشتركين، وهو مبدأ شرعي حيث ندب الشرع إلى التعاون على البر والتقوى كما جاء في قوله تعالى: { وَتَعَاوَنُوا عَلَى الْبِرِّ وَالتَّقْوَىٰ وَلَا تَعَاوَنُوا عَلَى الْإِثْمِ وَالْعُدْوَانِ } (المائدة:2). وجاء في صحيح مسلم أن النبي صلى الله عليه وسلم قال: "مثل المؤمنين في توادهم وتراحمهم وتعاطفهم كمثل الجسد الواحد إذا اشتكى منه عضو تداعى له سائر الجسد بالسهر والحمى". (صحيح مسلم، باب: تراحم المؤمنين وتعاطفهم، حديث رقم 2585). وهذا موافق لما نص عليه قرار مجمع الفقه الإسلامي بجدة (قرار بشأن التأمين وإعادة التأمين 1985م) "العقد البديل الذي يحترم أصول التعامل الإسلامي هو عقد التأمين التعاوني القائم على أسس التبرع والتعاون".

وتجدر الإشارة إلى أنه يجب الفصل بين صندوق المشتركين وبين صندوق الشركة المخولة باستثمار أموال الصندوق إما عن طريق المضاربة أو الوكالة بالاستثمار (Ali, M. M., Hassan, R., & Hasan, S. M. (2015) وذلك تقديراً للخلافة بين الصندوق، والفصل مهم في التأمين الإسلامي خلافاً للتأمين التقليدي المبني على عقد المعاوضة، وقد نص على هذا الشرط قانون الخدمات المالية الإسلامية في القسم السادس في المادة 91 (IFSA 2013). وانظر أيضاً: مجلس الخدمات المالية الإسلامية، معيار متطلبات الملاءة للتأمين التكافلي، 2010م، ص5).

الغرض من التأمين التعاوني:

يرى المجيزون للتأمين الإسلامي أن الهدف من التأمين ليس استرباحاً كما هو الحال في التأمين التجاري المحرم، وإنما القصد منه التعاون والتضامن بين المساهمين على الحوادث والنكبات وتفتت المخاطر. (محمد صالح العثيمين، فتاوى إسلامية، جمع وترتيب: محمد مسند، ج3، ص6)، وانظر "مجلس الخدمات المالية الإسلامية، المبادئ الإرشادية لضوابط التأمين التكافلي، 2009م، ص2). إلا أن بعض المعاصرين يرون أن هذا الهدف لم يعد قائماً في شركات التأمين الإسلامي في العصر الراهن، (عيسى زكي شقره، 2016، قصد الاسترباح في عقود التأمين التكافلي، المجلد: 31 العدد: 104، ص542) ويرى الباحث أن هذا الأمر الذي أشار إليه بعض المعاصرين من عدم التزام شركات التكافل بهذا المبدأ ليس وليدة العصر، وإنما بدأ في وقت الشيخ عبد العزيز بن باز رحمه الله، (مجلة البحوث الإسلامية العدد (50) عام 1418 هـ) وذلك بعد صدور "بيان من اللجنة الدائمة للبحوث العلمية والإفتاء حول التأمين التجاري، والتأمين التعاوني. فإنه سبق أن صدر من هيئة كبار العلماء قرار بتحريم التأمين التجاري بجميع أنواعه... كما صدر قرار من هيئة كبار العلماء بجواز التأمين التعاوني، وهو الذي يتكون من تبرعات من المحسنين، ويقصد به مساعدة المحتاج والمنكوب، ولا يعود منه شيء للمشتريين، لا رؤوس أموال، ولا أرباح، ولا أي عائد استثماري؛ لأن قصد المشترك ثواب الله سبحانه الله وتعالى بمساعدة المحتاج، ولم يقصد عائداً دنيوياً... ولكن ظهر في الآونة الأخيرة من بعض المؤسسات والشركات تلبس على الناس، وقلب للحقائق حيث سماوا التأمين التجاري المحرم تأميناً تعاونياً، ونسبوا القول بإباحته إلى هيئة كبار العلماء من أجل التبرير بالناس والدعاية لشركاتهم، وهيئة كبار العلماء بريئة من هذا العمل كل البراءة؛ لأن قرارها واضح في التفريق بين التأمين التجاري والتأمين التعاوني، وتغيير الاسم لا يغير الحقيقة، ولأجل البيان للناس، وكشف التلبس، ودحض الكذب والافتراء صدر هذا البيان". (المعاملات المالية أصالة ومعاصرة ج4، ص225).

هياكل التأمين التعاوني والإشكاليات الموجهة لها:

يتضح من قراءة واستقراء آراء المجيزين للتأمين التعاوني الإسلامي أنهم يفرقون بينه وبين التأمين التقليدي بجامع أن التأمين التعاوني مبني على التبرع بخلاف التأمين التقليدي، بالإضافة إلى أن التأمين التجاري يهدف إلى الاسترباح، بخلاف التأمين الإسلامي الذي يبنى على النهج، والتعاون وهذا العنصران يمثلان مرتبطاً الفرس بين النظامين إسلامياً وتقليدياً. وقيل الخوض في الحديث عن الإشكالات الموجهة نحو التأمين الإسلامي (التعاوني/التبالي) يجدر بنا الإشارة إلى هياكل التأمين التعاوني، ومدى وجود العنصرين المذكورين سلفاً التعاون والتبرع.

هناك جملة من الهياكل المستخدمة في التأمين التعاوني في كثير من الدول العربية والإسلامية، (Bouheraoua, S., & Ali Jinnah Ahmad, (2015). M.) ومن الهياكل المستخدمة: هيكل المضاربة والوكالة والوقف والوديعة والجعالة وغيرها من الهياكل. وبما أن ماليزيا من أكبر الدول التي تعتنى بصناعة التأمين الإسلامي (التكافل)، فإن هذه الدراسة تركز على الهياكل المستخدمة في ماليزيا مع الرجوع إلى الهيئات والمؤسسات المعنية بإصدار اللوائح والأنظمة لمؤسسات المالية الإسلامية.

هيكل المضاربة (Mudharabah model):

هيكل المضاربة: من العقود الجائزة شرعا عقد المضاربة، وهي عقد مشاركة بحيث يقدم أحد الطرفين رأس المال ويسمى رب المال ويقدم الآخر عملا ويسمى "المضارب"، ويكون الربح بين رب المال وبين المضارب على حسب الاتفاق، أما في حالة الخسارة فيتحملها رب المال وحده.

النموذج 1



في هذا النموذج، تكون العلاقة بين المساهمين بعضهم بعضا علاقة التبرع، أي كل من المساهمين يتبرع لإنشاء الصندوق التكافلي، ومن ثم يعين هؤلاء المساهمون واحدا منهم أو غيرهم لإدارة الصندوق "مشغل التكافل" وتكون العلاقة بينهم وبين هذا المشغل علاقة عقد مضاربة بحيث يقوم هذا الأخير بإدارة الصندوق المتمثلة في دفع التعويضات لحملة الوثائق "المساهمين" في حالة حدوث خطر، وكذلك استثمار الأموال، وفي حالة وجود الأرباح يتم تقاسم الربح بين المساهمين "رب المال" وبين المضارب "مشغل التكافل" على حسب النسبة المتفق عليها، والفائض التأميني يرجع إلى الصندوق.

ويجدر الانتباه إلى أن هيكل المضاربة هو أول هيكل استثماري لشركات التكافل في ماليزيا، (Ali, M. M. 2016، ص 6) وبما أن هذا الهيكل يقوم على التقاسم في الأرباح، ففي حالة عدم وجود الأرباح فإن بعض شركات التكافل في ماليزيا تقوم بتعديل هيكل المضاربة بحيث لا يتم تقاسم الربح بين المساهمين وبين مشغل التكافل، وإنما يتم تقاسم الفائض التأميني وهي من الإشكاليات الشرعية الواردة في تطبيقات هذا الهيكل في صناعة التكافل. (Engku Ali, R.A. & Odierno, H.S. P. (2008))

هيكل الوكالة: (Wakalah model)

هيكل الوكالة

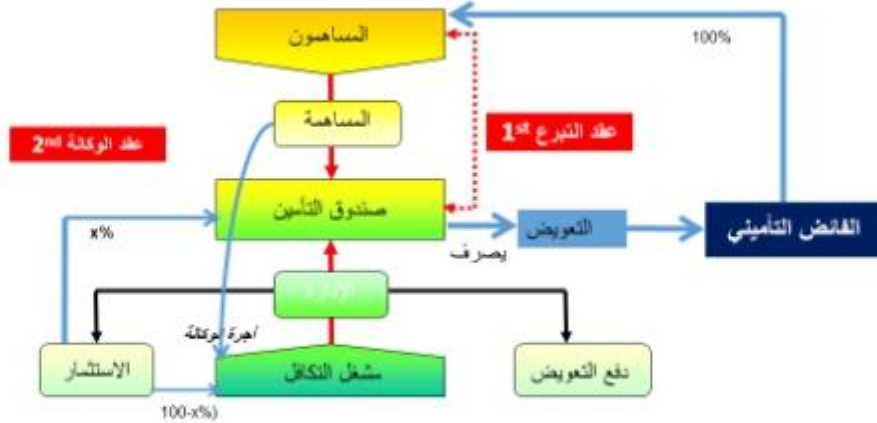

من الهياكل المنتشرة في شركات التكافل هيكل الوكالة، ويقوم المساهمون باشتراكات لإنشاء الصندوق على أساس التبرع، وتكون العلاقة بينهم علاقة عقد التبرع، وللصندوق في هذه الحالة شخصية اعتبارية، ثم يقوم الصندوق بتوكيل شخص ويسمى "مشتغل التكافل" وتكون العلاقة بين الصندوق وبين مشتغل التكافل علاقة عقد المعاوضة "الوكالة بأجرة/ الوكالة بالاستثمار" بحيث يقوم مشتغل التكافل باستثمار الأموال ويأخذ الأجرة على الوكالة، كما يؤكل أيضا بالاكنتاب ودفع التعويضات، ونفقات التشغيل كرسوم إعادة التشغيل. وفي هذا الهيكل يعود الفائض التأميني إلى الصندوق مرة أخرى.

ويجدر التنبيه إلى أن الفرق بين الهيكل الأول والثاني من حيث التطبيق أن هيكل المضاربة يسمح للمضارب أن يتقاسم في الربح بخلاف هيكل الوكالة، في حين أن هيكل الوكالة يمكن الوكيل من أخذ الأجرة قبل البدء في العمل بخلاف هيكل المضاربة؛ فلا يجوز للمضارب أن يأخذ شيئاً إلا في حالة تحقيق الأرباح.

ونلاحظ أن معيار هيئة المحاسبة والمراجعة بالبحرين اعتمد هذين الهيكلين المعايير الشرعية لهيئة المحاسبة والمراجعة، (المعيار الشرعي رقم 26) - في التأمين، الفقرة (3) حيث ذكر أن التأمين الإسلامي بقوله: "يقوم على أساس الالتزام بالتبرع من المشتركين لمصلحتهم، وحماية مجموعهم بدفع اشتراكات يتكون منها صندوق التأمين الذي تديره هيئة مختارة من حملة الوثائق، أو تديره الشركة المساهمة المرخص لها بممارسة خدمات التأمين، على أساس الوكالة بأجر، وتقوم الهيئة المختارة من حملة الوثائق أو الشركة باستثمار موجودات التأمين على أساس المضاربة أو الوكالة بالاستثمار".

الإشكالات الواردة على هياكل التكافل

ذهب بعض المعاصرين إلى التطبيقات المعاصرة للتأمين الإسلامي لا يخرج عن التطبيقات للتأمين التجاري المحرم، وذلك أن اشتراط التبرع مقابل التبرع من قبيل المعاوضة وليس تبرعاً محضاً، وقد أشار رفيق المصري (الخطر والتأمين، ص 99): أنه "مما يؤخذ على رأي المجيزين للتأمين التعاوني، والمانعين للتأمين التجاري: أنهم رأوا أن التعاونيات كالتبرعات يغتفر فيها من الغرر ما لا يغتفر في المعاوضات، وهذا فيه نظر؛ لأن (أنتبرع لك على أن تتبرع لي) ليس من التبرعات، بل هو من المعاوضات"، ويؤكد ذلك عبد الله بن منيع (عبد الله بن منيع، التأمين بين الحلال والحرام، ص 16) حيث نص على أن "التأمين التعاوني في واقعه شركة تأمين مكونة من المشتركين أعضاء فيها. فكل مشترك يحمل في الشركة صفتين: صفة المؤمن، باعتباره باشتراكه فيها عضواً له حق في الفائض بقدر نسبة اشتراكه، وعليه الالتزام بالمشاركة في سداد عجز صندوق الشركة عن الالتزام بالتعويضات بنسبة مشاركته، وله صفة المؤمن له، باعتباره باشتراكه أحد عملاء الشركة، ملتزماً بدفع القسط التأميني، وتلتزم الشركة له بدفع تعويضه عما يلحقه من ضرر مغطى بموجب تعاقده مع الشركة، وبهذا ينتفي وجه التفريق بين التأمين التعاوني والتأمين التجاري، فكلاهما شركة تأمين، تتفق إحداها مع الأخرى في جميع خصائص التأمين من حيث عناصره، ومن حيث الإلزام والالتزام، والصفة القانونية لكل القسمين. فشركة التأمين التجارية شركة قائمة على الإلزام والالتزام والحقوق والواجبات، وكذلك الأمر بالنسبة لشركة التأمين التعاونية، فهي شركة قائمة على الإلزام والالتزام والحقوق والواجبات...".

بالإضافة إلى ما سبق نلاحظ أن المشترك هو نفسه المستفيد يعني ذلك، أن المشترك "الملتزم بالتبرع" المؤمن "وعندما يأخذ التعويض يصير المؤمن" فيكون المتبرع هو نفسه المستفيد من التبرع، وهذا يخل بمبدأ التبرع. ثم إن الالتزام بالتبرع فيه شبهة المعاوضة، والذي يقابله التزام الصندوق بالتبرع له المتمثل في دفع التعويضات حالة الخسارة أو الحوادث، وإذا استسلمنا أن هذا الهيكل انتقل من كونه تبرعاً إلى معاوضة فإن الغرر الذي حرم على أساسه التأمين التجاري يقع في هذا الهيكل أيضاً، وقد نص معيار الأيوبي (المعيار الشرعي رقم 26) في التأمين الإسلامي، الفقرة (4/ج) على هذه العلاقة في قوله: "العلاقة بين حملة الوثائق وبين الصندوق عند الاشتراك هي علاقة التزام بالتبرع، والعلاقة بين المستفيد وبين

الصندوق عن التعويض هي علاقة التزام الصندوق بتغطية الضرر حسب الوثائق والوثائق. وهذا الص يفيده بأن العلاقة بين حملة الوثائق "المساهمين" وبين الصندوق علاقة الالتزام بالتبرع، وهذا الذي جعل بعض المعاصرين أن هذه العلاقة لا تخرج عن علاقة معاوضة. (عبد العظيم أبوزيد، 2011، ص 7).

وقد يقال إنه وإن كانت العلاقة بين الطرفين مبنية على الالتزام بالتبرع، إلا أن الالتزام بالتبرع عند المشترك ناجز بحيث يساهم في إنشاء الصندوق، في حين أن الالتزام بالتعويض من قبل الصندوق محتمل؛ قد يقع وقد لا يقع، وهذه بخرجه من دائرة المعاوضة. أضف إلى ذلك أن التعويض قد يكون أكثر مما تبرع به المشترك، وقد يكون أقل، وهذا يدعم إبقاء العلاقة بين الصندوق وبين المشترك علاقة التبرع وليست المعاوضة.

ومع هذا فإن التزام التبرع من المشترك هو عين الإشكال في هذه القضية ولا يضر كون التبرع من المشترك أقل أو أكثر من التعويض، ويعني ذلك أن العقد عقد معاوضة وليس تبرعاً، ويضاف إلى ذلك أن الالتزام بالتبرع من قبل الصندوق لا يخرج في دائرة المعاوضات. (عبد العظيم أبوزيد، 2011م، ص 7).

الفائض التأميني:

الفائض التأميني هو ما يبقى بعد دفع التعويضات والنفقات التشغيلية وغيرها، ففي هيكل المضاربة فليست للشركة أن يأخذ من الفائض التأميني بدليل أن العقد بينها وبين المشتركين عقد المضاربة، ولا يجوز للمضارب أن يأخذ من الفائض بناء على هذا الهيكل، وإنما يجوز له النسبة من الربح، والفرق بين الربح وبين الفائض التأميني أن هذا الأخير ما زاد على رأس المال بخلاف الفائض التأميني. لذلك نجد أن بعض شركات التأمين تلجأ إلى تعديل هيكل المضاربة، وهذا في حد ذاته مخالف للبناء الشرعي للعقد. ويضاف إلى ما سبق، أن بعض الشركات ترجع الفائض التأميني إلى المشتركين وهذا قد يناقض أصل التبرع الذي بُني العقد عليه.

ويقسم الفائض التأميني في بعض الشركات بين المشتركين وبين الشركة "مشغل التكافل، بعض الشركة يبني هذا التقسيم على عقد الجعالة، وكأنه حوافز للشركة، في حين أن المشتركين يأخذون الفائض التأميني بناء على هذا المال لهم، وبعض الشركات ترجع الفائض التأميني إلى الصندوق نفسه، ولا شك أن الإشكال الشرعي الموجه لهذا التطبيق ما يزال قائماً بدليل أن المتبرع لا يرجع إليه ما تبرع به، لأن ملكية المال قد انتقلت منه، وكيف ترجع إليه أيضاً. ويضاف إلى ذلك أن التزام الصندوق بالتعويض لا ينفك عن التزام الشركة نفسها، فكان الشركة هي التي تقرر الأخذ من الفائض التأميني وهي نفسها. (Elshefat, M. R 2017)

وهذا التقسيم مخالف لما نص عليه قرار (ندوة البركة الثانية عشرة للاقتصاد الإسلامي، قرارات وتوصيات ندوات البركة للاقتصاد الإسلامي ص212) حيث نص على أن الشركة المخولة بالمضاربة تقوم بفصل حساب الصندوق إلى "حسابين منفصلين، أحدهما لاستثمار رأس المال، والآخر لحسابات أموال التأمين ويكون الفائض التأميني حقاً خالصاً للمشاركين".

توظيف صندوق الزكاة للتأمين التعاوني:

الزكاة في اللغة يطلق ويراد بها النماء والتطهير والبركة والصلاح وغيرها، وفي الاصطلاح الشرعي، هناك تعريفات كثيرة حسب المذاهب الفقهية ولكننا يمكن أن نعرف الزكاة بأنها: "حق واجب في مال مخصوص في وقت مخصوص لتحقيق رضى الرب تعالى. وتركبة النفس والمال والمجتمع"، فالزكاة ركن من أركان الإسلام ودعائمه الأساسية. فقد وردت الآيات القرآنية لبيان المستحقين للزكاة، وذلك في قوله تعالى: ﴿ إِنَّمَا الصَّدَقَاتُ لِلْفُقَرَاءِ وَالْمَسْكِينِ وَالْعَامِلِينَ عَلَيْهَا وَالْمُؤَلَّفَةِ قُلُوبُهُمْ وَفِي الرِّقَابِ وَالْغَارِمِينَ وَفِي سَبِيلِ اللَّهِ وَابْنِ السَّبِيلِ مَقْرَضَةً مِّنَ اللَّهِ وَاللَّهُ عَلِيمٌ حَكِيمٌ ۝۶۰﴾. (التوبة: 60).

أما الأهداف والمقاصد التي تتغياها الزكاة فكثيرة جداً، منها ما يتعلق بالفرد ومنها ما يتعلق بالمجتمع، ومن أهداف الزكاة الاجتماعية، أن فيها إقامة المصالح العامة للمسلمين، والتي قد ترجع إلى حفظ الدين كما في مصرف "وفي سبيل الله" ومواساة الفقير والمسكين كما في مصرف "الفقراء والمسكين" وكذلك تشجيع المصلحين بين أفراد المجتمع كما في مصرف "والغارمين".

ويرى القرضاوي (يوسف القرضاوي، 2001م. دور الزكاة في علاج المشكلات الاقتصادية، ص44) أن الزكاة يمكن أن تكون وسيلة مهمة بحيث يكون الأساس للتكافل الاجتماعي عند المسلمين، وهذا بدوره يقدر أن يكون بديلاً أو مكملاً لصندوق التأمين التعاوني في الوقت الحاضر، مؤكداً أن الزكاة يمكن أن "تقوم بنوع فريد من التأمين الاجتماعي ضد الكوارث، ومفاجآت الحياة، وسبق كل ما عرفه العالم بعد- من أنواع التأمين، وفضلاً عن السبق الزمني لهذا التأمين الذي حققه الإسلام لأبنائه بنظام الزكاة، نراه أسمى وأكمل وأشمل من التأمين الذي عرفه الغرب في العصر الحديث بمراحل ومرحل، فالتأمين على الطريقة الغربية لا يعوض إلا من اشتراك بالفعل في دفع أقساط محددة لشركة التأمين، وعند إعطاء التعويض يعطى الشخص المنكوب على أساس المبلغ الذي أمن به، لا على أساس خسائره وحاجته، فمن كان قد أمن بمبلغ أكبر أعطى تعويضاً أكبر، ومن كان مبلغه أقل كان نصيبه أقل، مهما عظمت مصيبتة، وكثرت حاجته، وذوو الدخل المحدود يؤمنون عادة بمبالغ أقل، فيكون حظهم إذا أصابتهم الكوارث أدنى، وذلك أن أساس التأمين الغربي التجارة، والكسب من وراء الأشخاص المؤمن لهم، أما التأمين في الإسلام فلا يقوم على اشتراط دفع أقساط سابقة، ولا يعطى المصاب بالجائحة إلا أساس حاجته، وبمقدار ما يجبر كسره، ويفرج ضائقته".

وهيكل التأمين التكافلي المعاصر على أساس الزكاة يحقق كثيراً من المقاصد الشرعية في تشريع الزكاة، وذلك نظراً لاحتياجات الناس إلى التأمين التكافلي في هذا العصر.

وإذا نظرنا إلى ماليزيا كأحدى الدول الرائدة في صناعة التكافل الإسلامي عالمياً إلا أن نشاط التكافل المصغر ضئيل نوعاً ما (Ahmed MH 2016)، وعلى الرغم من قلة الاهتمام بهذا الجانب إلا أن الباحث يرى أن ثمة تطبيقات لهذا النوع من التأمين التكافل المصغر، ففي عام 2007 تم تأسيس شركة التأمين التكافلي المصغر بالتعاون بين شركة إخلاص للتأمين التكافلي واتحاد المزارعين الماليزيين، وقد استفادت هذه التجربة بتوقيع اتفاقية بين الشركة وبين مركز الزكاة الذي يضم 10 وكالات لجباية أموال الزكاة بغية تكوين صندوق التكافل بحيث يوظف هذا الصندوق لدفع أقساط نيابة عن الفقراء ويدفع الفوائد في حالة الوفاة والعجز والأمراض المزمنة وتكاليف الدفن وتكاليف المستشفيات (Ahmed MH 2016). واقترحت (Noor Ashikin Mohd Rom و Zuriah Abdul Rahman 2012) تدخل الحكومة الماليزية في دعم التكافل المصغر في ماليزيا، وذلك إما بإيجاد خطة تساعد هؤلاء الفقراء أو يكون من الزكاة. لأن حاجة الناس إلى التأمين التكافلي في هذا العصر لا يقل أهمية عن حاجتهم إلى الطعام والشراب.

كيفية هيكلية التأمين بصندوق الزكاة:

خروجاً من الإشكاليات الموجهة ضد الهياكل المستخدمة في التأمين التكافلي في الصناعة التكافلية المعاصرة، وبحثاً عن بديل مناسب للعصر الحديث، وموافقاً لمقاصد الشريعة عامة، ومقاصد الزكاة خاصة، فإن الصيرورة إلى هيكلية التأمين التكافلي على الزكاة قد يكون بديلاً مناسباً للتأمين المبني على الأقساط والاشتراكات من المساهمين "حملة الوثائق"، لأن الزكاة لها ارتباط وثيق جداً بالتأمين. (يوسف كمال، الزكاة وترشيد التأمين المعاصر، 1986م ص 130).

ويضاف إلى أن التأمين التكافلي الإسلامي يهدف بشكل عام على تغطية كافة المجتمع الإسلامي من الحاجة والعوز، كما يقوم على حماية المسلمين جميعاً ضد الكوارث والحوادث، وهذا ما نجده في هيكلية التأمين الإسلامي على الزكاة وغيرها من الأدوات. (محمد بلتاجي، عقود التأمين من وجهة الفقه الإسلامي، 2008م، ص 168).

يقوم هذا الهيكل بتوظيف صندوق الزكاة للتأمين التكافلي، بحيث لا يفرض على المستفيدين قسطاً مالياً كما هو المطبق حالياً، وإنما يؤخذ من الأموال الزكوية "صندوق الزكاة" لإنشاء الصندوق التكافلي "التأمين الإسلامي"، ومن ثم تعيين شخص يقوم بإدارة هذا الصندوق، إما بوصفه وكيلاً بأجرة، أو مضارباً؛ فيستثمر هذه الأموال لصالح المستفيدين من التأمين، على أنه يجوز لمؤسسة الزكاة أن تكون شركة التأمين التي تعمل على استثمار الأموال الزكوية.

ويلاحظ أن هذا النموذج يحقق مبدأ التبرع دون أن ينتظر المشترك مقابلاً لما دفعه من الأقساط التأمينية، وهي خاصية لا توجد في الهياكل التكافلية الموجودة. كما يلاحظ أن العوض مقابل الاشتراك بحيث يكون الصندوق ملزماً بالتعويض، وإنما يرجع الأمر إلى الجهة التي تنظر في مدى احتياج الفرد للتأمين.

والهدف من استثمار هذه الأموال ليس فقط للاسترباح كما هو الحال في شركات التأمين، وإنما للحفاظ على الأموال الزكوية المجتمعة، وهذا مبني على القول بجواز استثمار أموال الزكاة.

ومن يمكن الاستئناس بما ورد في (الإمام الطبري، تفسير الطبري، ج10، ص 164) عن مجاهد في تفسير قوله تعالى: "الغارمين" فذكر مانصه: "من احترق بيته، أو يصيبه سيل، فيذهب متاعه، ويدان على عياله، فهذا من الغارمين".

الفصل بين الصناديق:

يعمل هذا النموذج على الفصل بين الصندوقين: الأول: صندوق الاستثمار والثاني: صندوق الإدخار والمخاطر، فصندوق الاستثمار يستخدم لاستثمار أموال الزكاة وتنميتها؛ وذلك لضمان استمرارية وكفاءة الصندوق لتغطية التعويضات للمستحقين متقبلاً. أما صندوق المخاطر فيستخدم لدفع التعويضات للمستحقين من الأضرار.

على أنه يمكن للجهة المخولة وضع ضوابط وشروط للاستحقاق بناء على حاجة المجتمع ومتطلباته، كما يجوز للجهة المخولة أن تجعل الصندوق التأميني خاصاً لنوع من أنواع التأمين، أو خاصاً لنوع من المخاطر، الصحة مثلاً، بحيث يخدم الأضرار المعنوية بالزكاة، مع مراعاة القوانين واللوائح التنظيمية لكل بلد.

الإشكاليات الشرعية الواردة على الهيكل:

اشتراط التملك لمصارف الزكاة:

والتملك من ثلاثي "م ل ك" والملك يعني احتواه الشيء والقدرة على الاستبداد به، وفي الاصطلاح الشرعي (ابن نجيم، الأشباه والنظائر، ص 246) "قدرة يثبتها الشارع ابتداء على التصرف إلا لمانع" فهو بهذا المعنى هو وضع المال في حوزة الفقير أو المسكين وغيرهما من أصناف الزكاة بحيث يقدر على التصرف في المال بنفسه أو بالنيابة عنه. ومن هنا اختلف الفقهاء في اعتبار التملك في الزكاة على أقوال:

فذهب الحنفية (السرخسي، المبسوط، 1993م، ج2، ص 202، وانظر: علاء الدين الحصكفي، الدر المختار شرح تنوير الأبصار وجامع البحار، 2002م، ص126) والشافعية (الشريني، 1958م. مغني المحتاج، ج3، ص 106) والحنابلة (المرداوي، 1995م. الإنصاف في معرفة الراجح من الخلاف، ج7، ص246) إلى اشتراط التملك في كافة أصناف الزكاة.

في حين ذهب ابن تيمية (مجموع الفتاوى، 1995م، ج ٢٥، ص ٨٠)، إلى اشتراط التملك في أربعة أصناف الأولى فقط، وأضاف المالكية ابن السبيل (الونشريسي، 1981م. المعيار العربي، بيروت: دار الغرب الإسلامي، ج ١ ص ٣١٩).

وذهب إلى عدم الاشتراط الشوكاني الشوكاني، (الشوكاني، 1425هـ/2004م). السيل الجرار المتفق على حدائق الأزهري، دار ابن حزم، ص 264)، وذهب بعض المعاصرين إلى هذا القول أمثال: أبو الأعلى المودودي وأبو زهرة (أبو الأعلى المودودي، 1985م. فتاوى الزكاة. ط 1. جدة: المركز العالمي لأبحاث الاقتصاد الإسلامي. ص55).

ويلاحظ أن القول الأول والثاني يتفقان في اشتراط التملك في الأصناف الأربعة الأولى، واختلفا في إدخال مصرف "ابن السبيل". بخلاف القول الثالث الذي ذهب إلى عدم اشتراط التملك رأساً.

سبب الخلاف:

ولعل سبب الخلاف راجع إلى اللام الواردة في آية الزكاة (إِنَّمَا الصَّدَقَاتُ لِلْفُقَرَاءِ وَالْمَسْكِينِ وَالْعَامِلِينَ عَلَيْهَا وَالْمُؤَلَّفَةَ قُلُوبُهُمْ وَفِي الرِّقَابِ وَالْغَارِمِينَ وَفِي سَبِيلِ اللَّهِ وَابْنِ السَّبِيلِ قَرِيبَةً مِّنَ اللَّهِ وَاللَّهُ عَلِيمٌ حَكِيمٌ). (التوبة: 60). حيث يرى أصحاب القول الأول أن "اللام" في الآية للتملك ولا يتصور التملك إلا بفتح الزكاة إلى المستحق نفسه أو إلى وكيله، ولأن اللام الموجودة في الآية أضيفت لمن يصح منه الملك من الأصناف، فدل ذلك على اشتراط التملك، وبقيّة الأصناف معطوفة على الفقراء والمساكين. في حين يرى من لم يشترط التملك أن اللام في الآية ليست للتملك؛ وإنما لبيان المصرف والمستحقين، ويؤيد ذلك أن أداة حصر المتمثلة في "إنما" موجودة قبل اللام للدلالة على أن الآية لبيان أن الزكاة تصرف لهؤلاء الأصناف لا غير، ويضاف إلى ذلك أن الخبر في الآية محذوفة، ولا بد من تقدير، فهل نقره ب"مملوكة" فيقال: "إنما الصدقات مملوكة للفقراء"؟ فإذا سلم هذا التقدير في الأصناف الأربعة الأولى فلا يستقيم المعنى فيما عداهم، فالتقدير المناسب في هذه الحالة هو وضع "مصرف" فنقول "إنما الصدقات مصرفة للفقراء..." ويستقيم بهذا التقدير المعنى.

حل إشكالية اشتراط التملك:

سبق أن تناول البحث إشكالية التملك الواردة في هيكله صندوق التأمين التكافلي المصغر على الزكاة، وذكرنا اتجاهات العلماء في اعتباره وعدم اعتباره.

ويرى الباحث أن قول من لم يشترط التملك يحقق مقاصد الزكاة من جانب، ويتماشى مع متطلبات العصر وحاجات الناس في هذا الوقت، ويؤيد القول بعدم اشتراط التملك ما ورد عن عباس رضي الله عنهما أنه يقول: "يعتق من زكاة ماله، ويعطي في الحج"، فإذا جاز ذلك فلا عبرة لأشراط التملك في الأصناف كلها، وهذا يتفق مع مذهب الفقهاء في جواز تحرير الأسير من مصرف "وفي الرقاب" دون تملكه هذا المال وإنما يكفي عتقه من المال، ويضاف إلى ذلك جواز العلماء الصرف من مصرف "وفي سبيل الله" لإعداد الغزاة دون تملكهم المال أنفسهم.

ويلاحظ أن اللام في الآية قد يحتمل "التملك" في لغة العرب، وقد يحتمل معنى العاقبة، كما يحتمل معنى الاختصاص، (أبو حيان، 1420هـ. البحر المحيط في التفسير، تحقيق: صدقي محمد جميل، بيروت: دار الفكر، ج5، ص 442)، وعليه فإن حمله على التملك دون غيره من الاحتمالات الأخرى يجب أن يستند إلى دليل آخر؛ فإذا ورد الاحتمال بطل الاستدلال. يمكن القول بأن الآية ليست دليلاً على من قال بالاشتراط في جميع الأصناف، وليست دليلاً لمن لم يشترط التملك، وهذا يتطلب إيجاد دليل يفصل القول بين الرأيين السابقين، وإذا سلمنا جدلاً أن اللام للتملك، فإن الجزء الثاني في الآية لم يرد باللام، وإنما ورد ب"في" الظرفية. (محيي الدين بن أحمد مصطفى درويش، 1415هـ، إعراب القرآن وبيانه، دار اليمامة - بيروت، ج4، ص118).

ويمكن حل هذه الإشكالية بأن التملك خاص بالأصناف الأربعة الأولى، وبأصناف لا يشترط، كما يمكن القول باشتراط التملك الجماعي كما ذكره بعض المعاصرين؛ لأن الهدف الأساسي في هذا الأمر هو قطع الملكية من المعطي والمزكي، وبما أنه وصل إلى الهيئة المسؤولة لجباية الزكاة، وتم تملك الهيئة فإن للهيئة التصرف في المال بناء على مصالح المستحقين. وهذا يمكن أن يكون حلاً وسطاً بين من يشترط التملك كلياً وبين من لم يشترط ذلك، وهذا يشبه ما ذهب إليه المودودي وأبو زهرة في صرف أموال الزكاة لإنشاء المؤسسات ذات العلاقة بمصارف الزكاة؛ لأن ذلك يرجع إليهم بالمصلحة. (أبو الأعلى المودودي 1985م. فتاوى الزكاة، ص55).

وهناك تطبيقات كثيرة مفادها عدم اشتراط التملك في كل الأصناف، أن المالكية (الذخيرة، القرافي: 521/2-522؛ مواهب الجليل، الحطاب: 232/3-233؛ الخرشني: 527/2)، والحنابلة (الشرح الكبير، ابن قدامة، ج1، ص 718، المرادوي، الإنصاف، ج3، ص 234)، إلى جواز قضاء دين المدين من مال الزكاة، ودفعها مباشرة للغير دون علم أو إذن المدين.

ويمكن الاستئناس بقرار مجمع الفقه الإسلامي (1986م) في جواز استثمار أموال الزكاة، حيث إن ذلك يعود إلى تملك المستحقين مآلاً، وقد نص القرار بأنه: "يجوز من حيث المبدأ توظيف أموال الزكاة في مشاريع استثمارية تنتهي بتملك أصحاب الاستحقاق للزكاة، أو تكون تابعة للجهة

الشرعية المسؤولة عن جمع الزكاة وتوزيعها، على أن تكون بعد تلبية الحاجة الماسة الفورية للمستحقين وتوافر الضمانات الكافية للبعد عن الخسائر، والله أعلم".

ويفيد كلام عمر بن عبد العزيز عدم اشتراط التملك لهؤلاء الأصناف (البخاري، كتاب (24) استعمال إيل الصدقة وألبانها لأبناء السبيل، حديث رقم 1501) و (مسلم كتاب (28) حكم المحاربين والمرتدين، حديث رقم 1077) حيث قال: " هذه منازل الصدقات ومواضعها إن شاء الله وهي ثمانية أسهم.. منها سهم ابن السبيل، يقسم ذلك لكل طريق على قدر من يسلكها، ويمر بها الناس، لكل رجلٍ راحلٍ من ابن السبيل ليس له مأوى، ولا أهل يأوي إليهم، فيقطع حتى يجد منزلاً أو يقضي حاجته، ويُجعل في منازل معلومة على أيدي أمناء، لا يمر بهم ابن سبيل له حاجة إلا أووه، وأطعموه، وعلفوا دابته؛ حتى ينفذ ما بأيديهم إن شاء الله".

إشكالية ضياع حق المستحقين:

من الإشكالية الواردة في هذا النموذج ضياع حق المستحقين، وهذه الإشكالية قد ينصب في صالح من يشترط التملك. على أن هناك صندوقين في صناعة التكافل: صندوق الاستثمار وصندوق المخاطر ((Ali, M. M., Hassan, R., & Hasan, S. M. (2015))، وهذا يجعل صناعة التكافل الإسلامي في تطبيقه المعاصر يأخذ طابع تجاري، والذي يتمثل في استخدام هياكل استثمارية مثل "الوكالة والمضاربة أو هياكل هجينة.

وعلى الرغم مما سبق فإن التخوف ليس في محله؛ وذلك أن صرف هذه الأموال إلى هيكل التأمين التكافلي المصغر يخدم مقاصد الزكاة في سد حاجة الفقراء والمساكين ومن في حكمهم؛ لأن المقصود من تشريع الزكاة هو سد حاجات المستحقين الأصلية: من طعام، ومسكن، وعلاج، وقضاء دين، وسائر مالا بدّ لهم منه. وإنشاء المؤسسات يحقق للمستحقين ذلك المقصود، فلا يكون صرفها في إنشاء المؤسسات ضياعاً لها".

ويرى الباحث أن هيكل التأمين التكافلي بشكل عام، والتأمين الصحي بشكل خاص يحقق الأهداف الاجتماعية التكافلية للمجتمع، والمتمثلة في مؤازرة الفقراء والمساكين ومن في حكمهم ممن لهم الحاجة الماسة إلى التأمين الإسلامي.

الخاتمة:

وبعد عرض النموذج المقترح الهادف إلى هيكل التأمين التكافلي الإسلامي على أسس الزكاة، يخلص البحث إلى القول بجواز بناء التأمين التكافلي على الزكاة، وأن الإشكالية الواردة في هذا المقترح من حيث اشتراط تملك الزكاة للمستحقين فهو قول لبعض الفقهاء، ويرى البحث عدم اشتراط ذلك في جميع الأصناف، استناداً لاختيار ابن تيمية وهو قول لبعض المعاصرين الذين أجازوا إنشاء المؤسسات من أموال الزكاة.

ويرى البحث إنشاء صندوقين في هذا النموذج: فالأول لنفع التعويضات للمستحقين، والثاني: لاستثمار الأموال الموجودة، شريطة أن يكون الاستثمار في أوجه مباحة شرعاً، وألا تكون المعاوضة والاسترباح هو الهدف الأساسي من هذا الاستثمار. وهذا لهدف استدامة الصندوق، والأرباح الناتجة من هذا الاستثمار ترجع إلى صندوق الأول، بحيث يكون رأس المال ملاءماً للمخاطر التي يغطيها الصندوق.

على أن هذا الهيكل يمكن أن يكون خاصاً لنوع من الأخطار مثل الصحة أو غيرها، مع الوضع في الحسبان اللوائح والأنظمة القانونية لكل بلد.

المراجع والمصادر:

- ابن تيمية، أحمد بن عبد الحلیم. 1995م. مجموعة الفتاوى، تحقيق: عبد الرحمن بن محمد بن قاسم. المملكة العربية السعودية: مجمع الملك فهد لطباعة المصحف الشريف، المدينة النبوية. أبو حيان، محمد بن يوسف. 1420 هـ. البحر المحيط في التفسير، تحقيق: صديقي محمد جميل، بيروت: دار الفكر.
- أبو زيد. عبد العظيم. 2011. البناء الشرعي للإسلام للتأمين الإسلامي (تكافل) المؤتمر العلمي الثامن للاقتصاد الإسلامي والتمويل، النوحة - قطر من 25 - 27 ديسمبر 2011م. الثنائين، سليمان إبراهيم (1993م). التأمين وأحكامه، ص 284؛ دار العواصم المتحدة. بيروت.
- الحصكفي، محمد بن علي بن محمد الحصني. 2002م. الدر المختار شرح تنوير الأبصار وجامع البحار، تحقيق: عبد المنعم خليل إبراهيم، بيروت: دار الكتب العلمية.
- الديباني، أبو عمرو بن محمد. (1432 هـ). المعاملات المالية معاصرة وأصلها. الرياض: مكتبة الملك فهد الوطنية.
- درويش، محيي الدين بن أحمد مصطفى 1415 هـ، إعراب القرآن وبيته، بيروت: دار اليمامة.
- السرخسي، محمد بن أحمد بن أبي سهل. 1993م. المبسوط، بيروت: دار المعرفة.
- الشربيني، محمد. 1958م. مغني المحتاج، القاهرة: مطبعة مصطفى البابي الحلبي، القاهرة.
- الشوكاني، محمد بن علي بن محمد بن عبد الله (1425 هـ/ 2004م). السبل الجرار المتدفق على حدائق الأزهار، دار ابن حزم. ط1.
- الضريير، الصديق محمد الأمين. (1990م). الغرر واثره في العقود في الفقه الإسلامي. بيروت: دار الجيل.
- العثمان. محمد أحمد (2012). شرط التملك في الزكاة ومدى تأثيره في عمل الجمعيات الخيرية الإسلامية. مجلة جامعة دمشق للعلوم الاقتصادية والقانونية، المجلد 28 - العدد الأول.
- الغفيلي، عبد الله بن منصور (2008). نوازل الزكاة «دراسة فقهية لتصيلية لمستجدات الزكاة» الرياض: دار الميمان للنشر والتوزيع.
- القرضوي، يوسف 2001م. دور الزكاة في علاج المشكلات الاقتصادية. دار الشروق

- كمال يوسف (1986م). الزكاة وترشيد التأمين المعاصر، مصر: دار الوفاء للطباعة والنشر والتوزيع. مجلس الخدمات المالية الإسلامية، (2009م) معيار المبادئ الإرشادية لضوابط التأمين التكافلي.
- مجمع الفقه الإسلامي بجدة . (1985م). قرار بشأن التأمين وإعادة التأمين 1985م، جدة: المملكة العربية السعودية.
- المرداوي، علاء الدين، 1995م. الإنصاف في معرفة الراجح من الخلاف، بيروت: دار إحياء التراث العربي
- المعهد الإسلامي للبحوث والتدريب، (2013م) قانون الخدمات المالية الإسلامية 2013م.
- المودودي، أبو الأعلى 1985م. فتاوى الزكاة ترجمة: رضوان أحمد الفلاح، مراجعة: رفيق المصري. المركز العالمي لأبحاث الاقتصاد الإسلامي.
- الونشريسي، 1981م. المعيار المعرب، بيروت: دار الغرب الإسلامي.
- الونشريسي، أحمد بن يحيى. 1981م. المعيار المعرب، بيروت: دار الغرب الإسلامي.
- المراجع باللغة الإنجليزية
- Ahmed MH (2016) Micro Takaful Insurance as a Tool to Guaranteeing Financing and Protecting Micro Enterprises. J Bus Fin Aff 5: 228. doi: 10.4172/2167-0234.1000228
- Ali, M. M. (2016). Takaful models: their evolution and future direction. *Islam and Civilisational Renewal (ICR)*, 7(4).
- Ali, M. M., Hassan, R., & Hasan, S. M. (2015). An Exploratory Study of Shari'ah Issues in the Application of Tabarru'for Takaful. *Global Review of Islamic Economics and Business*, 1(3), 164-174.
- al-Qaradaghi, A. M. Al-T a' mīn al-Islāmī (Beirut: Dār al-Basha'ir al-Islamiyyah, 2006), 311.
- Bouheraoua, S., & Ali Jinnah Ahmad, M. (2015). Takaaful Operation: Appraisal of the Existing Models and Exploration of a Possible Alternative, the Wadi'ah Model.
- Elshelhat, M. R. (2017). الإشكالات الفقهية حول الفاضل التأميني بشركات التكافل. *Journal of Fatwa Management and Research*, Vol 10, No 1.
- Engku Ali, R.A. & Odierno, H.S. P. (2008). Essentials Guide to Takaful (Islamic Insurance). Kuala Lumpur: CERT, p. 46
- Government of Malaysia, (2013). Law of Malaysia Act 759 Islamic Financial Services Act 2013, p. 36.
- Mikail, S. A., Ahmad, M. A. J., & Adekunle, S. S. (2017). Utilisation of zakāh and waqf fund in micro-takāful models in Malaysia: an exploratory study. *ISRA International Journal of Islamic Finance*.
- Rom, N. A. M., & Abdul Rahman, Z. (2012). Financial Protection for the Poor in Malaysia: Role of Zakah and Micro-Takaful = الحملة المالية للفقراء في ماليزيا: دور الزكاة و التكافل المصغر. *Journal of King Abdulaziz University: Islamic Economics*, 362(3330), 1-23.

TAKE ADVANTAGE OF THE PRINCIPLES OF STRATEGIC PLANNING IN ISLAMIC THOUGHT TO ACTIVATE JOB PERFORMANCE

Aadel Mohammed Alshehhi

المخلص

الاستفادة من مبادئ التخطيط الاستراتيجي في الفكر الإسلامي لتفعيل الأداء الوظيفي

أوضحت الإدارة والتخطيط الاستراتيجي من أهم السمات الأساسية في نجاح أي مؤسسة أو مشروع أو أعمال، فالتخطيط الاستراتيجي يساعد على تطور السلوك والمهارات طرق التفكير، ويلتقي التخطيط الاستراتيجي مع عدد من المبادئ العامة في الفكر الإسلامي والسنة المشرفة؛ حيث يزخر القرآن الكريم بالكثير من الآيات التي تشير إلى التخطيط الاستراتيجي، للوصول إلى الهدف المنشود، ومن نماذج التخطيط الاستراتيجي في القرآن الكريم في الجانب الاجتماعي قصة يوسف عليه السلام مع إخوته، وفي الجانب الإداري تخطيط يوسف عليه السلام لإدارة أموال البلاد، وفي الجانب التربوي قصة الخضر مع سيدنا موسى عليه السلام، وفي الجانب العسكري قصة يوم حنين، فقد أحكم الخالق سبحانه وتعالى ذلك التخطيط، على علم وبصيرة، واستفاد منه البشر في الحياة العملية والعلمية، فكان لزاماً على المخطط الإداري أن يكون على علم وبصيرة بالأمر الذي يخطط له، وأن تكون الرؤية من تخطيطه واضحة، والهدف منه محدد، وتلك أبرز خطوات التخطيط الاستراتيجي الجيد.

ويُعدُّ التخطيط الاستراتيجي في وقتنا الراهن مطلباً أساسياً لإنجاز الأعمال والمشاريع في شتى المجالات، ويحتاج أي عمل إلى تخطيط مقنن قبل البدء فيه؛ لإظهار الجوانب الجوهرية التي توضح طريقة العمل والتنبؤ بالنتائج المتوقعة، فالكمل يخطط بأسلوبه وطريقته.

ويختلف التخطيط الاستراتيجي عن التخطيط التقليدي؛ لقدرته على تحديد ما ينبغي أن يكون، من خلال التنبؤ بالنتائج، ووضع البدائل المناسبة، واحتمالات نسبة نجاح العمل المتوقعة، لذا كان للتخطيط الاستراتيجي الإداري دور كبير في الوصول إلى نتائج ذات جودة عالية، فهو يُعدُّ من أكثر الخطوات أهمية لإنجاز الأعمال، سواء كانت إدارية أو مؤسسية، فردية أو جماعية؛ كونه يبرز نقاط القوة والضعف منذ البدء في العمل، ويضع البدائل المناسبة، ويساعد على اتخاذ القرارات الصائبة لتحقيق الأهداف المنشودة، فهو بذلك يستخدم الأسلوب الوقائي عند وضع الاحتمالات التي قد تواجه العمل المُخطط له؛ وبالتالي فإن التخطيط الاستراتيجي لا بد أن تكون له أصول راسخة، حددت خطواته، ورسمت إجراءاته، فاستفاد منها البشر في تخطيط شؤون حياتهم من جميع جوانبها ومنها الجانب الإداري.

Abstract

Management and strategic planning have become one of the most essential features in the success of any institution, project or business. Strategic planning helps develop behavior, skills and ways of thinking, and strategic planning meets a number of general principles in Islamic thought and the honorable year; As the Holy Qur'an abounds in many verses that refer to strategic planning, to reach the desired goal, and examples of strategic planning in the Holy Qur'an on the social side are the story of Joseph, peace be upon him with his brothers, and on the administrative side, the planning of Joseph, peace be upon him, to manage the country's money, and on the educational side a story The vegetables with our master Moses, peace be upon him, and on the military side the story of the day of Nostalgia, the Almighty and the Almighty have tightened that planning, with knowledge and insight, and humans benefited from it in practical and scientific life. The vision from its planning is clear, and the goal is specific, and these are the most important steps of good strategic planning. Today, strategic planning is a prerequisite for the completion of works and projects in various fields, and any work needs to be codified planning before starting it. To show the essential aspects that clarify the way to work and predict the expected results, everyone plans his style and method. Strategic planning differs from traditional planning; Its ability to define what should be, through predicting the results, and developing appropriate alternatives, and the prospects for the expected success of the work, so strategic planning has a major role in achieving high-quality results, as it is considered one of the most important steps to accomplish business, whether it is administrative Or institutional, individual or collective; Since it highlights the strengths and weaknesses from the start of work, develops appropriate alternatives, and helps to make the right decisions to achieve the desired goals, so it uses the preventive method when setting up the possibilities that may face the planned work; Thus, strategic planning must have solid origins, defined its steps, and charted its procedures, so humans benefited from it in planning their affairs in all its aspects, including the administrative side.

مقدمة

يشهد عصرنا متغيرات متسارعة ومركبة في مختلف مناحي الحياة على جميع المستويات نتيجة تأثير العوامل والتطورات الكبيرة والمستمرة على المستوى العلمي والتقني، الأمر الذي حتم على المنظمات الحكومية والخاصة على حد سواء العمل على تغيير الاستراتيجيات والسياسات بشكل

دائم لكي تستطيع التكيف مع هذه التطورات إضافة إلى التغييرات البيئية (السياسية، الاقتصادية، التقنية، الاجتماعية...)، لذلك برزت الحاجة لوجود لادة جديدة متمثلة بالتخطيط الاستراتيجي كأحد أهم الأدوات الإدارية المتميزة بوصفه منهجاً ييسر بالمنظمة لتحقيق ماتصبو إليه بكفاءة و فاعلية⁽¹⁾.

لقد بدأ نظام التخطيط بالتركيز أولاً على التخطيط المالي ووضع الموازنات، والتخطيط قصير المدى، ثم عزز لاحقاً مع تطور الأعمال والظروف المحيطة إلى التخطيط متوسط المدى وطويل المدى، وتعدت العملية التخطيطية في المؤسسات والشركات الكبيرة ذات الأعمال والأقسام المتعددة لتظهر عمليات التخطيط الشامل (حمدان، وإريس، 2007: 6).

ومع ممارسة تلك المؤسسات للتخطيط الشامل وتوجيه اهتمامها نحو المنافسة والعولمة بدأت تلك المؤسسات والمنظمات الاهتمام بتحليل البيئة المحيطة فيما عرف بالتخطيط الاستراتيجي، الذي يركز على وضع المؤسسة الحالي من خلال تحليل البيئة الداخلية والخارجية، وتعرف نقاط القوة والضعف، والفرص والتهديدات التي تواجهها والأهداف التي تسهم في تفعيل أدائها⁽²⁾.

المبحث الأول

أسس التخطيط الاستراتيجي في الكتاب والسنة

يبرز الاهتمام المستحق بالتنمية البشرية باعتبارها أهم محاور التنمية والتفاعل مع المستقبل، وتحقيق التنمية الشاملة والمتواصلة والمؤدية إلى تجديد قوى المجتمع وتفعيل حراكها من خلال تنمية البشر وتحسين مستويات معيشتهم والتي هي غاية و طاقة محرقة للتقدم الحضاري والثقفي والعمراني، والاستفادة الواعية المثلى من منجزات الحضارات الإنسانية، حاضراً ومستقبلاً، وهذا يمكن أن يثقل عليه نظام تقييم الكفاءة⁽¹⁾.

يكتسب نظام تقييم الكفاءة أهمية كبيرة في مجال الوظيفة العامة، وذلك باعتبارها أحد الوسائل الهامة التي تكفل الكشف عن مدى صلاحية الموظفين وقدرتهم على القيام بواجبات الوظيفة وأعبائها ودورهم في تحقيق أهداف الجهة الإدارية في إدارة المرفق العام وتحقيق المصلحة العامة. ويسعى نظام تقييم الكفاءة إلى تحقيق العديد من الأهداف؛ لعل من أهمها النهوض بمستوى الخدمة التي يقدمها المرفق العام، وتقويم برامج واساليب تعيين الموظفين وتدريبهم، والكشف عن عيوب الإدارة ومشاكلها، وتحسين كفاءة الموظفين وإشعارهم بمسؤولياتهم المنوطة بهم⁽²⁾.

المطلب الأول

مبادئ رعاية الكفاءات في القرآن الكريم لتعزيز التخطيط الاستراتيجي

تعرف الإدارة في الإسلام على أنها: الولاية، أو الرعية، أو المتابعة، أو الأمانة؛ فكل منها يحمل معنى المسؤولية والالتزام بأداء الواجبات، والإحاطة بالأمر، والحفاظ على الأمانة، وبهذا المفهوم ينادي الإسلام بإسناد الولاية والرعية إلى الفرد من أفراد الجماعة، وبذلك يرى أن القيادة من ضروريات الجماعة؛ وذلك حرصاً على اجتماعات العمل والحياة مع الناس.

والكفاءة في القرآن الكريم يمكن توضيحها عن طريق إلقاء الضوء على مبادئ التنظيم الإداري، والتي تتمثل في الآتي:

أولاً: مبدأ وحدة الأمر:

من مبادئ التنظيم المهمة مبدأ وحدة الأمر، والذي يقصد به ألا يتلقى المرء وس أو امر إلا من رئيس واحد فقط، كما يقول المثل العامي: "المركب التي بها رئيسان تغرق"، ويؤكد على سلامة هذا المبدأ وجوده بشكل فطري في خلية النحل، فلا نجد لخلية النحل أكثر من ملكة، وإن كان هناك أكثر من ملكة مرشحة فإنه يتم سباق تنافسي بينهما؛ لتقضي إحداهما على الأخرى أو تطردها، وتظل الرئاسة لواحدة فقط، فإن كان لا بد من وجود ملكة قوية أخرى فإنها حينئذٍ يمكن أن تقود سرباً جديداً من النحل الصغير الناشئ، وتتطلب به لبناء خلية جديدة، وهكذا.

ثانياً: مبدأ تكافؤ السلطة والمسئولية:

وهو الذي ينطلق من قاعدة شرعية عريضة، مؤداها: أن يكون التكليف على قدر الوسع (لَا يَكْلَفُ اللَّهُ نَفْسًا إِلَّا وُسْعَهَا لَهَا مَا كَسَبَتْ وَعَلَيْهَا مَا اكْتَسَبَتْ رَبَّنَا لَا تُؤَاخِذْنَا إِنْ نَسِينَا أَوْ أَخْطَأْنَا رَبَّنَا وَلَا تَحْمِلْ عَلَيْنَا إصْرًا كَمَا حَمَلْتَهُ عَلَى الَّذِينَ مِنْ قَبْلِنَا رَبَّنَا وَلَا تُحَمِّلْنَا مَا لَا طَاقَةَ لَنَا بِهِ وَاعْفُ عَنَّا وَانصُرْنَا وَأَرْحَمْنَا أَنْتَ مَوْلَانَا فَانصُرْنَا عَلَى الْقَوْمِ الْكَافِرِينَ)⁽¹⁾؛ وذلك بالألا يتم تحميل أحد الأفراد مسؤولية، دون منحه سلطة متكافئة تمكنه من أدائها.

ولعل ما نلاحظه من السعي لكل شيء في الحياة، والحركة لتهدئة المهام المنوطة على خير وجه ينم عن توافر قدر كبير من السلطة، والصلاحية المكافئة والمنوطة للأشياء.

ثالثاً: مبدأ تفويض السلطة:

ومؤاده بإيجاز: أن السلطة تفوض والمسئولية لا تفوض، ومنه تنشأ سلسلة مستمرة ومتدرجة من تفويض السلطة، دون أن يفقد أي مستوى.

(1) هلال، فراس عصمت (2015-2016). تأثير التخطيط الاستراتيجي في أداء المنظمات "حالة وزارة التعليم العالي نموذجاً"، رسالة ماجستير في إدارة الأعمال، الجامعة الافتراضية السورية، دمشق.

(2) الدجني، إباد علي (2010-2011). دور التخطيط الاستراتيجي في جودة الأداء المؤسسي "دراسة وصفية تحليلية في الجامعات النظامية الفلسطينية"، رسالة دكتوراه في التربية، جامعة دمشق، ص 4.

(1) عمار، حامد: مواجهة العولمة في التعليم والثقافة، الهيئة المصرية العامة للكتاب، مكتبة الأسرة، 2006م، ص 35.

(2) المطيري، تركي سلطان: تقييم كفاءة الموظف العام في قانون الخدمة المدنية الكويتي، مجلة الشريعة والقانون، السنة السابعة والعشرون، العدد الثالث والخمسون، جامعة الإمارات العربية المتحدة، العين، 2013م، ص 397.

(1) سورة البقرة، الآية 286.

رابعاً: مبدأ تبادل المشورة:

لقد حظيت الشورى بمكانة عظيمة في التشريع الإسلامي، وأصبحت من المبادئ التي يقوم عليها نظام الحكم والإدارة في الدولة الإسلامية في مختلف العصور، ومما يؤكد ذلك: أن الله تعالى أوجب الرجوع إلى الأمة والجماعة عند اتخاذ القرارات المهمة، قال تعالى: (فَبِمَا رَحْمَةٍ مِنَ اللَّهِ لِنْتَ لَهُمْ وَلَوْ كُنْتَ فَظًا غَلِيظَ الْقَلْبِ لَانفَضُّوا مِنْ حَوْلِكَ فَاعْفُ عَنْهُمْ وَاسْتَغْفِرْ لَهُمْ وَشَاوِرْهُمْ فِي الْأَمْرِ فَإِذَا عَزَمْتَ فَتَوَكَّلْ عَلَى اللَّهِ إِنَّ اللَّهَ يُحِبُّ الْمُتَوَكِّلِينَ)(1).

وقد أمر الله جلا شانته المؤمنين أثناء ممارستهم لكل شئون الحياة الدنيا بتبادل المشورة في أمورهم، قال تعالى: (وَالَّذِينَ اسْتَجَابُوا لِرَبِّهِمْ وَأَقْلَمُوا الصَّلَاةَ وَأَمْرُهُمْ شُورَى بَيْنَهُمْ وَمِمَّا رَزَقْنَاهُمْ يُنْفِقُونَ)(2).

خامساً: مبدأ المساواة:

حيث جاء الإسلام بمبدأ المساواة، وكان بذلك أسبق في هذا المقام- مما يعرف من التشريعات في العصر الحديث، وفي الآيات القرآنية التي تدعو إلى المساواة قوله تعالى: (إِنَّمَا الْمُؤْمِنُونَ إِخْوَةٌ فَأَصْلِحُوا بَيْنَ أَخَوَيْكُمْ وَاتَّقُوا اللَّهَ لَعَلَّكُمْ تُرْحَمُونَ)(3).

سادساً: مبدأ العدالة:

تقوم الإدارة في الإسلام على مبدأ قاعدة العدالة بين الجميع، دون مراعاة للفروق الاقتصادية أو اللونية أو الجنسية، والتميز يقوم على أساس التقوى والعلم، والعمل الصالح وأداء الواجب الشرعي، يقول تعالى: (يَا أَيُّهَا النَّاسُ إِنَّا خَلَقْنَاكُمْ مِنْ ذَكَرٍ وَأُنْثَى وَجَعَلْنَاكُمْ شُعُوبًا وَقَبَائِلَ لِتَعَارَفُوا إِنَّ أَكْرَمَكُمْ عِنْدَ اللَّهِ أَتْقَاكُمْ إِنَّ اللَّهَ عَلِيمٌ خَبِيرٌ)(1). والآيات القرآنية التي وردت في الحث على العدالة كثيرة جداً، ومنها قوله تعالى: (إِنَّ اللَّهَ يَأْمُرُكُمْ أَنْ تُؤَدُّوا الْأَمَانَاتِ إِلَىٰ أَهْلِهَا وَإِذَا حَكَمْتُمْ بَيْنَ النَّاسِ أَنْ تَحْكُمُوا بِالْعَدْلِ إِنَّ اللَّهَ نِعِمَّا يَعِظُكُمْ بِهِ إِنَّ اللَّهَ كَانَ سَمِيعًا بَصِيرًا)(2).

المطلب الثاني**خصائص أصحاب الكفاءات الإدارية في القرآن الكريم****خاصية الجدارة:**

لقد طبقت الإدارة في الإسلام مبدأ الكفاءة، والجدارة، والأمانة، والقدرة على الأداء والعمل، وتولية الوظائف العامة قيل أن تأخذ به النظم الإدارية الحديثة، ومعنى ذلك: أن الإدارة الإسلامية ربطت بين السلوك التنظيمي وبين الإنتاج في العمل، وقد التزمت الإدارة الإسلامية بما جاء في القرآن الكريم والسنة النبوية الشريفة، فقد قال تعالى: (قَالَتْ إِحْدَاهُمَا يَا أَبَتِ اسْتَأْجِرْهُ إِنَّ خَيْرَ مَنِ اسْتَأْجَرْتَ الْقَوِيُّ الْأَمِينُ)(3).

خاصية الرقابة:

وتعني الرقابة في الإدارة الإسلامية: الإشراف والمتابعة من سلطة أعلى؛ بقصد معرفة كيفية سير الأمور والأعمال، والتأكد من أن المورد المتاحة تستخدم وفقاً للخطة الموضوعه، وكل ذلك وفق مبادئ الشريعة الإسلامية، ونجد في كتاب الله وسنة رسوله صلى الله عليه وسلم ما يوجب الرقابة، فالقرآن الكريم يقول: (وَلَا تُطِيعُوا أَمْرَ الْمُشْرِكِينَ . الَّذِينَ يُفْسِدُونَ فِي الْأَرْضِ وَلَا يُصْلِحُونَ)(4).

خاصية الالتزام بالمسئولية:

تعني المسئولية في الإسلام: التزام الشخص بأن ينتهز بالأعباء الموكلة إليه، وتحمل التزاماته واختياراته أمام الله تعالى، ثم تأتي مسؤولية التنفيذ التي تقوم على مبدأ الالتزام الشخصي والإعلام والبيان، فيقول تعالى: (هَذَا بَيَانٌ لِلنَّاسِ وَهُدًى وَمَوْعِظَةٌ لِّلْمُتَّقِينَ)(1).

ويستنتج الباحث أن الإدارة التربوية الإسلامية تستند على التعاون والمشورة الصادقة المخلصة، وعلى العدل والمساواة، وعمادها الشعور بالمسئولية لدى كل فرد في حدود مسؤولياته، وميزتها عن غيرها أنها لا تسعى لتحقيق الأهداف النبوية فحسب؛ بل تسعى لتحقيق الفلاح في الآخرة كذلك.

المطلب الثالث**أسس رعاية الكفاءات في مجال التخطيط الاستراتيجي في السنة المطهرة**

كان رسول الله - صلى الله عليه وسلم - أصفى الناس بصيرة، فاستخرج مكونات وذخائر أصحابه، كل على قدر طاقته واستعداده وميوله، قبي عهد الرسول - صلى الله عليه وسلم شجعت الكفاءات، فهذا عبد الله بن رواحة شاعر من شعراء الدعوة، قال له النبي صلى الله عليه وسلم: " عليك بالمشركين"(2).

لقد شجع الرسول أكفاء شعراء الدعوة فنافحوا عنه بأشعارهم وسيوفهم وأقلامهم وعلى رأسهم حسان بن ثابت فرضي الله عنهم أجمعين، وقد سار على ذلك خلفاؤه وأصحابه واتباعه وسارت الأجيال في القرون المفضلة مستهدية بهدي رسول الله صلى الله عليه وسلم، حيث "عني المسلمون في

(1) سورة آل عمران، الآية 159.

(2) سورة الشورى، الآية 38.

(3) سورة الحجرات، الآية 10.

(1) سورة الحجرات، الآية 13.

(2) سورة النساء، الآية 58.

(3) سورة القصص، الآية 26.

(4) سورة الشعراء، الآيات: 151-152.

(1) سورة آل عمران، الآية 138.

(2) الزهراني: مسفر: إستراتيجيات الكشف عن الموهوبين والمبدعين ورعايتهم بين الاصله المعاصرة، دار طيبة، مكة المكرمة، 1424 هـ، ص 41.

مختلف العصور بالكشف عن أصحاب الكفاءات والناهبين والتميزين بسرعة الحفظ وسلامة التفكير وقوة الملاحظة وإحاطهم بمجالس العلماء، والحقاء بهم وإكرامهم من قبل الحكام⁽³⁾.

في هذه الأمثلة وغيرها ظهر الإبداع في مجتمعات المسلمين الخيرة في كافة الميادين، وكان إنصاف المجتمع الإسلامي كقبلاص بتقدير الكفاءات المختلفة، وذلك في القرون التالية للقرون الأولى المفضلة، وعبر العصور الإسلامية المتعاقبة ازدهرت فنون عديدة، كالعمارة الإسلامية التي تجلت في المساجد والخانات والقلاع والأسوار والقصور، والتي تظهر كفاءة المسلمين وتقف شاهداً على الإبداع والكفاءة⁽¹⁾.

قال ابن تيمية: "يجب على ولي الأمر أن يولي على كل عمل من أعمال المسلمين أصح من يجده لذلك العمل، قال النبي - صلى الله عليه وسلم - : "من ولي من أمر المسلمين شيئاً فولى رجلاً وهو يجد من هو أصح للمسلمين منه فقد خان الله ورسوله". وفي رواية: "من ولي رجلاً على عصبية وهو يجد في تلك العصابة من هو أَرْضَى الله منه فقد خان الله ورسوله وخان المؤمنين"⁽²⁾.

وقال عمر بن الخطاب رضي الله عنه: "من ولي من أمر المسلمين شيئاً فولى رجلاً لمودة أو قرابة بينهما فقد خان الله ورسوله والمسلمين". وهذا واجب عليه فيجب عليه البحث عن المستحقين للولايات من نوابه على الأمصار؛ من الأمراء الذين هم نواب ذي السلطان والقضاة ونحوهم، ومن أمراء الأجناد ومقدمي العساكر الصغار والكبار وولاة الأموال: من الوزراء والكتاب والشادين والسعاة على الخراج والصدقات وغير ذلك من الأموال التي للمسلمين. وعلى كل واحد من هؤلاء أن يستتيب ويستعمل أصح من يجده؛ وينتهي ذلك إلى أئمة الصلاة والمؤذنين والمقرئين وأمراء الحاج والبريد والعيون الذين هم القصاد وخزان الأموال وحراس الحصون والحدادين الذين هم البوابون على الحصون والمدائن ونقباء العساكر الكبار والصغار وعرفاء القبائل والأسواق ورؤساء القرى الذين هم "الدهاقين". فيجب على كل من ولي شيئاً من أمر المسلمين من هؤلاء وغيرهم أن يستعمل فيما تحت يده في كل موضع أصح من يقدر عليه⁽³⁾.

وعن يزيد بن أبي سفيان قال قال أبو بكر حين بعثني إلى الشام: "يا يزيد إن لك قرابة عسيت أن تؤثرهم بالإمارة وذلك أكثر ما أخاف عليك فإن رسول الله صلى الله عليه وسلم قال: "من ولي من أمر المسلمين شيئاً فأمر عليهم أحداً مُحَابَاةً فعليه لعنة الله لا يقبل الله منه صرفاً ولا عدلاً حتى يدخله جهنم ومن أعطى أحداً حمى الله فقد انتهك في حمى الله شيئاً بغير حقه فعليه لعنة الله أو قال تبرأت منه ذمة الله"⁽¹⁾.

ويختلف عدد معاونين بحسب اتساع العمل، فقد يختار فرداً أو فردين أو ثلاثة، وقد يختار فريقاً كاملاً للعمل. والاستعانة قد تكون في تنفيذ العمل فقط، فيكون معاون قائماً على التنفيذ، وقد يكون بالإدلاء بالرأي، فيكون معاون في هذه الحالة مشيراً أو مستشاراً، وينبغي أن يكون المدير ذا طبيعة تسمح لمن يعملون تحت إدارته بالمبادرة بعرض ما يرونه في صالح العمل، ولا ينتظرون حتى يطلب منهم الاستشارة، وقد كان رسول الله صلى الله عليه وسلم في النروة العليا من استشارة أصحابه حتى يقول أبو هريرة: "مارأيت أحداً قط كان أكثر مشورة لأصحابه من رسول الله صلى الله عليه وسلم"⁽²⁾.

وقال ابن خلدون: "كان صلى الله عليه وسلم يشاور أصحابه ويفاوضهم في مهماته العامة والخاصة ويخص مع ذلك أبا بكر بخصوصيات أخرى حتى كان العرب الذين عرفوا الدول واحوالها في كسرى وقيصر والنجاشي بسمون أبا بكر وزيره ... وكذا عمر مع أبي بكر، وعلي وعثمان مع عمر"⁽³⁾.

والاستشارة ينبغي أن تكون في أهلها، قال ابن عباس رضي الله عنهما: "وكان القراء أصحاب مجلس عمر ومشاورته، كهولاً كانوا أو شباناً"⁽⁴⁾. والقراء: العلماء والعباد.

وقال سفيان الثوري: "ولیکن أهل مشورتك أهل التقوى وأهل الأمانة ومن يخشى الله عز وجل"⁽¹⁾، وقال البخاري: "وكانت الأئمة بعد النبي صلى الله عليه وسلم يستشيرون الأئمة من أهل العلم في الأمور المباحة ليأخذوا بأسهلها، فإذا وضح الكتاب أو السنة لم يتعدوه إلى غيره، اقتداءً بالنبي صلى الله عليه وسلم"⁽²⁾؛ لأن غير المؤتمن والجاهل الذي لا يعلم وكذلك من لا يتقي الله لا يستشار ولا يلتفت إلى قوله.

وقد بينت سنة الرسول صلى الله عليه وسلم - كما مر - أن على الوالي أو مدير العمل أن يختار الأصح فيمن يسند إليهم العمل وألا يختار أحداً وفي المسلمين من هو أولى منه بذلك⁽³⁾.

قال ابن تيمية: "فالواجب في كل ولاية الأصلح بحسبها. فإذا تعين رجلان أحدهما أعظم أمانة والآخر أعظم قوة؛ قدم أنفعهما لتلك الولاية. وأقلهما ضرراً أفيها؛ فيقدم في إمارة الحروب الرجل القوي الشجاع - وإن كان فيه فجور - على الرجل الضعيف العاجز وإن كان أميناً؛ كما سئل الإمام أحمد: عن الرجلين يكونان أميرين في الغزو واحد قوي فاجر والآخر صالح ضعيف مع أيهما يغزى؟ فقال: أما الفاجر القوي ففوته للمسلمين وفجوره على نفسه؛ وأما الصالح الضعيف فصلاحه لنفسه وضعفه على المسلمين فيغزى مع القوي الفاجر. وقد قال النبي صلى الله عليه وسلم: "إن الله يؤيد هذا الدين بالرجل الفاجر"⁽⁴⁾. وروي: "بأقوام لا خلاق لهم"⁽⁵⁾. وإن لم يكن فاجر أكان أولى بإمارة الحرب ممن هو أصح منه في الدين إذا لم يسد مسده.

(3) القريظي، عبد المطلب: الموهوبون والمتفوقون خصائصهم واكتشافهم ورعايتهم، ط1، دار الفكر العربي، ط1، 2005م، ص14.

(1) القريظي: عبد المطلب، المرجع السابق، ص15.

(2) رواه الحاكم في صحيحه. أخرجه الحاكم برقم 7023، وقال: صحيح الإسناد، وسقط الحديث من الذهبي في التلخيص وضعفه الألباني.

(3) ابن تيمية: مجموع الفتاوى، الجزء 28، ص246-247.

(1) أخرجه أحمد في المسند برقم 21.

(2) أخرجه الترمذي في سننه، حديث رقم 1714.

(3) تاريخ ابن خلدون، ص295.

(4) البخاري، حديث رقم 4642.

(1) الشريف، محمد بن شاکر: موسوعة فقه السياسة الشرعية، مرجع سابق، ص31.

(2) صحيح البخاري، كتاب الاعتصام، باب قول الله تعالى (وأمرهم شورى بينهم) "الشورى: 38".

(3) الشريف، محمد بن شاکر: موسوعة فقه السياسة الشرعية، مرجع سابق، ص32.

(4) أخرجه البخاري، حديث رقم 3062، ومسلم حديث رقم 178.

(5) أخرجه أحمد، حديث رقم 20454.

ولهذا كان النبي صلى الله عليه وسلم يستعمل خالد بن الوليد على الحرب منذ أسلم وقال: "إن خالداً سيف سله الله على المشركين" (6). مع أنه أحياناً قد كان يعمل ما ينكره النبي صلى الله عليه وسلم.. ومع هذا فما زال يقدمه في إمارة الحرب؛ لأنه كان أصلح في هذا الباب من غيره (1).

وإذا كانت الحاجة في الولاية إلى الأمانة أشدّ من الأمانة، مثل حفظ الأموال ونحوها؛ فأما استخراجها وحفظها فلا بد فيه من قوة وأمانة فيؤلى عليها شاد قوي يستخرجها بقوته وكتاب أمين يحفظها بخبرته وأمانته. وكذلك في إمارة الحرب إذا أمر الأمير بمشاوره أهل العلم والدين جمع بين المصلحتين؛ وهكذا في سائر الولايات إذا لم تتم المصلحة برجل واحد جمع بين عدو؛ فلا بد من ترجيح الأصلح أو تعدد المولى إذا لم تقع الكفاية بواحد تام. ويقدم في ولاية القضاء: الأعم الأورع الأكفأ؛ فإن كان أحدهما أعلم والأخر أروع؛ قدم – فيما قد يظهر حكمه ويخاف فيه الهوى – الأورع؛ وفيما يدق حكمه ويخاف فيه الاشتباه الأعم، ويقدمان على الأكفأ إن كان القاضي مؤيداً تأييداً تاماً من جهة والي الحرب أو العامة. ويقدم الأكفأ إن كان القضاء يحتاج إلى قوة وإعانة للقاضي أكثر من حاجته إلى مزيد العلم والورع؛ فإن القاضي المطلق يحتاج أن يكون عالماً عادلاً قادراً. بل كذلك كل وال للمسلمين في صفة من هذه الصفات نقصت ظهر الخلل بسببها (2).

والكفاءة إما بقهر ورهبة وإما بإحسان ورغبة، وفي الحقيقة فلا بد منهما. وسئل بعض العلماء: إذا لم يوجد من يولى القضاء؛ إلا عالم فاسق أو جاهل دين؛ فأيهما يقدم؟ فقال: إن كانت الحاجة إلى الدين أكثر لغلبة الفساد قدم الدين. وإن كانت الحاجة إلى العلم أكثر لخفاء الحكومات قدم العالم. وأكثر العلماء يقدمون ذا الدين؛ فإن الأئمة متفقون على أنه لا بد في المتولي من أن يكون عدلاً أهلاً للشهادة؛ واختلفوا في اشتراط العلم؛ هل يجب أن يكون مجتهداً أو يجوز أن يكون مقلداً أو الواجب تولية الأئمة فالأئمة كيفما تيسر؟ على ثلاثة أقوال ... ومع أنه يجوز تولية غير الأهل للضرورة إذا كان أصلح الموجود فيجب مع ذلك السعي في إصلاح الأحوال حقاً يكمل في الناس ما لا بد لهم منه من أمور الولايات والإمارات ونحوها؛ كما يجب على المعسر السعي في وفاء دينه وإن كان في الحال لا يطلب منه إلا ما يقدر عليه، وكما يجب الاستعداد للجهاد بإعداد القوة ورباط الخيل في وقت سقوطه للعجز فإن ما لا يتم الواجب إلا به فهو واجب وأهم ما في هذا الباب معرفة الأصلح، وذلك إنما يتم بمعرفة مقصود الولاية، ومعرفة طريق المقصود؛ فإذا عرفت المقاصد والوسائل تم الأمر (1).

ولعل عمل كفاءة تناسبه قال عمر رضي الله عنه لسليط بن عمرو الانصاري رضي الله عنه: "لولا عجلة فيك لوليتك، ولكن الحرب زبون لا يصلح لها إلا الرجل المكث" (2). فإمكانات سليط الحربية توهله أن يتولى أمرها لكنه رضي الله عنه كانت به – كما يقول صلى الله عليه وسلم – عجلة، والحرب لا يناسبها العجلة وإنما تحتاج إلى القائد المكث أي الرزين غير العجول لما يترتب على العجلة في الحروب من مخاطر (3).

ولا يدخل السن أو المال في مفردات الكفاءة، فقد يكون الكفاء فقيراً ليس غنياً وهذا ظاهر، لكن الذي قد لا يتصور كثير من الناس حصوله وجود الكفاءة مع حداثة السن والثابت من كثير من الوقائع أنه تلازم بين الكفاءة وكبر السن، فقد ولي رسول الله صلى الله عليه وسلم شباباً حديثي السن ولايات كبيرة وكان تحتهم أشياخ كبار كما ولي أسامة بن زيد رضي الله عنهما وهو شاب حديث السن لا يتجاوز العشرين إمرة جيش كان فيه أمثال أبي بكر الصديق رضي الله عنه، وقد أمر عثمان بن أبي العاص على تنقيف، وكان أصغرهم، لما رأى من حرصه على الإسلام والتفقه في الدين، قال يوسف بن الماجشون: "قال لنا ابن شهاب أنا وابن أخي وابن عم لي ونحن غلمان أحداث نسأل عن الحديث: "لا تحقروا أنفسكم لحداثة أسنانكم فإن عمر بن الخطاب رضي الله عنه كان إذا نزل به الأمر المعضل دعا الفتيان فاستشارهم بيئغي حدة عقولهم" (4).

ولا شك أن التطور الهائل الذي يشهده العالم حالياً، وما تترتب عليه من تغيرات في مختلف مجالات وميادين الحياة، قد استوجب حدوث تغير شامل في العلوم والمعارف الطبيعية والإنسانية، وبما أن علم الإدارة يُعدُّ أحد العلوم الإنسانية، فكان لا بد أن يحظى بقدر كبير وكافٍ من التطور. وفي ظل استمرار التطور في علم الإدارة، فإن الدراسات والأدبيات تؤكد على أن العنصر البشري سيظل هو العنصر الحيوي لأداء كافة الوظائف، فإن كفاءة وفعالية أداء أية منظمة يرتبط ارتباطاً وثيقاً بفعاليتها وكفاءة العنصر البشري، مما يتطلب الرقي بقدراته وتوفير الرعاية اللازمة له، وتوفير المناخ الملائم الذي يتحقق معه الرضا الوظيفي والولاء الدائم للمنظمة التي تحضنه وينتمي إليها (1).

الكفاءة عند علماء التربية:

يرى علماء التربية أن الحضارة هي مجموعة قيم تتنامى وتنتشر في المجتمعات وتشكل المخزون الثقافي والفكري والعلمي لهذه المجتمعات، وهي حالة تغير ديناميكي ومستمر. فإن معضلة الشعوب هي في تخريج أجيال فعالة منجزة حضارياً وقادرة على مواجهة تحديات عصرها سواء مادياً أو معنوياً أو تحديات سياسية وثقافية وعسكرية، ومعظم الأهل يسعون لأن يكون ولدهم فعالاً منتجاً أو حافظاً لكرامته، متعلماً منتجاً، وباختصار أن يقدموا له خلاصة خبراتهم في الحياة وأقصى أمانيتهم في كفاءته وفعاليتته وبخاصة في حياته. واليوم ونحن ندخل عصر المعلوماتية والمعرفة وتحدياته الكبيرة، وهذا العصر يتطلب مرونة تعليم دائمة ومستمرة، ويتطلب حرية في الخيار وفي تكوين الشخصية الذاتية، ويتطلب توازناً في النفسية في عصر ضاغط اقتصادياً ومتنوع استهلاكياً ومتنوع في أساليبه مع الأطفال في طفولتهم (1).

إن تقارير الأداء الوظيفي توفر معلومات غزيرة عن الموظفين من ناحية كفاءتهم وعلاقتهم وسلوكهم لكي يساعد إدارة الموارد البشرية على إيجاد مركز للمعلومات، وذلك لتحقيق أهداف المنظمة من خلال تحسين الأداء الكلي للمنظمة عن طريق تطوير قدرات ومهارات الموظفين (2). وتتمثل أهداف تقييم الأداء فيما يلي:

- (6) أخرجه أحمد، حديث رقم 43 ليس فيه حرف التوكيد "إن".
- (1) الشريف، محمد بن شاكر: موسوعة فقه السياسة الشرعية، مرجع سابق، ص 32.
- (2) الشريف، محمد بن شاكر: موسوعة فقه السياسة الشرعية، مرجع سابق، ص 32-33.
- (1) ابن تيمية: مجموع الفتاوى، الجزء 28، ص 354-359.
- (2) البلاذري، أحمد بن يحيى: فتوح البلدان، الجزء الأول، ص 247.
- (3) الشريف، محمد بن شاكر: موسوعة فقه السياسة الشرعية، مرجع سابق، ص 34.
- (4) السنن الكبرى للبيهقي، الجزء العاشر ص 193.
- (1) عيسى، حمد علي عبد الله: تأثير المناخ التنظيمي على الأداء الوظيفي للعاملين "دراسة ميدانية على إدارة المنافذ بشؤون الجنسية والجوازات"، رسالة ماجستير، كلية العلوم الإدارية، جامعة العلوم التطبيقية، مملكة البحرين، 2014م، ص 17.
- (1) النداء، مروان سليمان سالم: فعالية برنامج مقترح لزيادة الكفاءة الاجتماعية للطلاب الخجولين في مرحلة التعليم الأساسي، رسالة ماجستير في علم النفس، كلية التربية، الجامعة الإسلامية، غزة، يناير 2008م، ص 3.
- (2) ضرار، قاسم: تنمية المهارات الإشرافية على المستوى التنفيذي الأول، دراسة وصفية تحليلية لمهام وتحديات الإشراف في المنظمات الإدارية، معهد

1- الأهداف الإدارية:

إن من أول أهداف تقييم الكفاءات هو توفير معلومات أساسية وضرورية لبعض القرارات المتصلة بالعمل كالتقنيات، التعيين، النقل، الفصل، المكافآت، أو في اتخاذ القرارات المناسبة بتجديد العقود أو إنهاؤها، وأيضاً تمكن الإدارة من تحديد مستويات كفاءة وأداء الموظفين وسلوكهم، وعلى ضوءها يتم اتخاذ القرارات الإدارية المناسبة.

2- أهداف البحوث والدراسات:

إن استخدام البيانات والمعلومات المتجمعة عن تقييم كفاءات للموظفين، حيث أن نتائج هذه المعلومات تساعد في تقييم برامج الحوافز القائمة وقياس مستوى الرضا والدافعية للعمل، وكذلك التأكد من مدى صحة إجراءات التقييم.

3- أهداف التوجيه والتطوير:

إن تقييم الكفاءات يساعد على تحسين وتطوير وسائل الاتصال بين الرؤساء والمرؤوسين، وما ينتج من مقابلات تقييم الكفاءات الدورية بخلق مناخ ملائم للعلاقة بين الرؤساء والمرؤوسين، مما يساعد بشكل ملحوظ على تطوير وتحسين مستوى الأداء والدافعية للعمل، وكذلك التخطيط بالشكل السليم للتطوير الوظيفي(1).

4- تحديد الاحتياجات التدريبية:

يكون ذلك من خلال نتائج الدراسة التحليلية لتقييم كفاءات الموظفين، فإنه يتم وضع الخطط والبرامج التدريبية التي تساهم في تنمية مهارات الموظفين والتي تساعد في معالجة مشاكل العمل التي تواجههم، وتطوير أساليب العمل لديهم، وكذلك يمكن الحكم على مدى كفاءة وفعالية برامج التدريب القائمة(2).

5- تحقيق استمرارية الرقابة والإشراف على أداء الموظفين:

كي تتحقق استمرارية الرقابة والإشراف على كفاءات الموظفين، فإن تقييم الأداء يجب أن يكون بشكل دوري، وتوضع هذه التقديرات الدورية من قبل الرؤساء والمشرفين عن أداء مرؤوسيه، وبالمرقبة المستمرة والإشراف تكون التقديرات عادلة وواقعية.

6- كشف القدرات والطاقات الكامنة لدى الموظفين:

هناك طاقات وقدرات للموظفين غير المستغلة في عملهم الحالي، ولاكتشاف تلك القدرات الكامنة لديهم يتم إجراء تقييم للأداء الوظيفي، وبناء على نتائجها تتبين قدراتهم واستعدادهم ومهاراتهم، وعلى أساسه يتم إيجاد الحلول الملائمة للموظفين، لتقسيم العمل والمسؤوليات والأدوار بينهم على حسب تلك القدرات والطاقات.

7- كشف جوانب الضعف والقصور في كفاءة الموظفين:

إن ما يمكن المشرفين من معرفة جوانب الضعف والقصور في كفاءة وأداء الموظفين هي ما تظهره تقارير تقييم الأداء الوظيفي، ويتم معالجة ذلك القصور في الأداء، وتقوية الضعف بالتدريب وتنمية المهارات وتحديد التوجيه اللازم لتقييم وجانب الضعف، وتمكن تقارير الأداء الوظيفي للموظفين ذوي المستوى المتدني في الأداء معرفة نقاط الضعف والقصور لديهم لكي يتمكنوا من تقييم ومعالجة أدائهم بجهودهم الذاتية(1).

8- كشف المشكلات الإدارية:

إذا أظهرت نتائج تقييم الأداء في أحد الأقسام أن غالبية الموظفين غير متعاونين مع الرئيس المباشر، وقد تكون هذه الظاهرة بسبب وجود صراع بين الموظفين ورئيسهم أو بسبب كراهيتهم له، فإن الحل لمثل هذه المشكلات الإدارية وعلاجها يتم بالكشف عنها، ومن ثم تشخيصها عن طريق نظام تقييم الأداء، إن الإدارة العليا هي الجهة المعنية بالتدخل والعمل على توجيه المشرف إلى السلوك الإداري الصحيح أو نقله إلى قي آخر وحل جميع المشاكل، ولتحسين وتقادي أي ميول أو نزاعات شخصية كالترقية والنقل والتحفيز وغيرها، فإن نظام تقييم الأداء يوفر الأساس الموضوعي والعاقل لكثير من أنشطة ومجالات الموارد البشرية(2).

المبحث الثاني

الإدارة العامة، الرياض، 1999م، ص113.
(1) علاقي، مني عبد القادر: إدارة الموارد البشرية "المنهج الحديث في إدارة الافراد"، مكتبة دار زهران للنشر والتوزيع، جدة، 1993م، ص295-296.

(2) هاشم، زكي محمود: إدارة الموارد البشرية، مرجع سابق، ص297.

(1) المرجع السابق، ص22.

(2) هاشم، زكي محمود: إدارة الموارد البشرية، مرجع سابق، ص296.

تفعيل الأداء الوظيفي عند علماء الإدارة

يفهم عدد من علماء الإدارة مدلول الكفاءة على أنه الفاعلية، ويشير إلى أداء الأشياء الصحيحة (لكونها تتصل بالأهداف)، أما الكفاءة فهي أداء الأشياء بطريقة صحيحة (فهي أكثر اتصالاً بكيفية أداء الأعمال)، حيث يعبر الأداء عما يتمتع به العاملون في المنظمات الإدارية بصفة عامة والمنظمات الأمنية بصفة خاصة من مهارات وقدرات وإمكانات اتصالية، فإذا كان الأداء مناسباً للعمل المطلوب إنجاز، فإنه يحقق الغرض منه، أما إذا كان الأداء لا يرقى إلى المستوى المطلوب لإنجاز العمل، فإن ذلك يتطلب تطوير وسائل الاتصالات المستخدمة لرفع كفاءة العاملين وتحسين أدائهم بهدف الوصول إلى المستوى المطلوب من الأداء. حيث تؤثر الاتصالات بشكل فعال على الأداء، لأن الاتصالات هي التي يتم من خلالها نقل التعليمات والأوامر، وكذا استفسارات العاملين سواء من الرؤساء في المستويات الإدارية العليا، أو من الزملاء في نفس المستويات الإدارية عن كيفية أداء بعض الأعمال والمهام، أو مواجهة بعض المشكلات التي تعترض أدائهم (1).

المطلب الأول

تعريف الأداء الوظيفي

والأداء بصفة عامة هو تحويل المدخلات التنظيمية كالمواد الأولية والمواد نصف المصنعة إلى مخرجات تتكون من سلع وخدمات بمواصفات فنية ومعدلات محددة (2).

يعرف الأداء بأنه: "سلوك وظيفي هادف لا يظهر نتيجة قوى أو ضغوط نابعة من داخل الفرد فقط، ولكنه نتيجة تفاعل وتوافق بين القوى الداخلية للفرد والقوى الخارجية المحيطة به" (1).

وقد اعتبر البعض الأداء سلوك يهدف إلى تحقيق نتيجة، فعرفه بأنه: "سلوك يحدث نتيجة"، وهو ما يقوم به الفرد استجابة لمهمة معينة سواء قام بها بذاته أو فرضها عليها الآخرون (2).

ويتجه كثير من الباحثين إلى التمييز بين السلوك والإنجاز والأداء، ويرون أن السلوك: "هو ما يقوم به الأفراد من أعمال في المنظمات التي يعملون بها، أما الإنجاز: هو ما يبقى من أثر أو نتائج بعد أن يتوقف الأفراد عن العمل، في حين أن الأداء: هو التفاعل بين السلوك والإنجاز أي أنه يعبر عن مجموع الأعمال والنتائج معاً" (3).

وتشير مجموعة المفاهيم السابقة إلى أن الأداء هو سلوك وظيفي هادف يقوم به العاملون لإنجاز الأعمال المكلفين بها، أو بمعنى أدق مستوى قيامهم بالعمل، فبناءً على هذا المستوى يتحدد الأداء إذا كان متميزاً أو جيداً أو متوسطاً أو متدنياً، وهذا يتوقف على عدة عوامل خارجية وداخلية، فالعوامل الخارجية تتضمن: مؤثرات البيئة الخارجية كمناخ العمل والعلاقة بالزملاء والرؤساء والتجهيزات المكتبية، ومدى ملاءمة مكان العمل ومستوى ضغوط العمل، أما العوامل الداخلية فتتضمن: قدرات ومهارات العاملين واستعداداتهم واتجاهاتهم نحو العمل ورضاهم الوظيفي، وهذه ترتبط إلى حد كبير بالعوامل الوراثية والعوامل البيئية والوسط الثقافي المحيط ونوع التعليم والخبرات المكتسبة (4).

ويستنتج الباحث مما، أن الكفاءة عند علماء الإدارة عبارة عن:

- 1- جهد يهدف إلى تحويل المدخلات الخاصة بالتنظيم إلى عدد من المخرجات (منتجات) ذات مواصفات محددة بأقل تكلفة ممكنة.
- 2- جهد يسعى إلى تحقيق أهداف الوظيفة، ومن ثم أهداف المنظمة ككل.
- 3- سلوك وظيفي هادف يظهر نتيجة تفاعل وتوافق بين القوى الداخلية للفرد والقوى الخارجية المحيطة به.
- 4- سلوك يهدف إلى تحقيق نتيجة.
- 5- اتجاهاً تتكون من أفعال وردود أفعال.
- 6- محصلة تفاعل بين ثلاثة محددات رئيسية هي: الدافعية الفردية، ومناخ وبيئة العمل والقدرة على إنجاز العمل.
- 7- يرتبط الأداء بعوامل خارجية تتضمن مناخ العمل والعلاقة بالزملاء والرؤساء والتجهيزات المكتبية ومدى ملاءمة مكان العمل ومستوى ضغوط العمل.
- 8- يرتبط الأداء بعوامل داخلية تتضمن قدرات ومهارات الفرد واستعداداته واتجاهاته نحو العمل ورضاه الوظيفي.

المطلب الثاني

معايير الأداء وفوائده للمنظمات

- (1) المانع، محمد بن علي: تقنيات الاتصال ودور هافي تحسين الأداء "دراسة تطبيقية على الضباط العاملين بالأمن العام"، مرجع سابق، ص 70-71.
- (2) الخزامي، عبد الحكيم أحمد: تكنولوجيا الأداء من التقييم إلى التحسين "تقييم الأداء"، الجزء الثاني، مكتبة ابن سينا، القاهرة، 1999م، ص 19.
- (1) هلال، محمد عبد الغني حسن: مهارة إدارة الأداء، ط2، مركز تطوير الأداء والتنمية، القاهرة، 1999م، ص 19-20.
- (2) الخزامي، عبد الحكيم أحمد: تكنولوجيا الأداء من التقييم إلى التحسين "تقييم الأداء"، مرجع سابق، ص 19.
- (3) درة، عبد الباري إبراهيم: تكنولوجيا الأداء البشري، مهارة أساسية من مهارات القيادات في المؤسسات الشريفة العربية، ورقة عمل مقدمة إلى الحلقة العلمية للمهارات الإدارية العليا المنعقدة بالطائف، جامعة نايف العربية للعلوم الأمنية، الرياض، 1998م، ص 3-4.
- (1) هلال، محمد عبد الغني حسن: مهارة إدارة الأداء، مرجع سابق، ص 2.

لقد بدأ الاهتمام بعملية قياس الأداء في الآونة الأخيرة يأخذ اهتماماً كبيراً نظراً لما يمثله ذلك من قدرة المنظمة من تقييم الممارسات الحالية ومدى ارتباطها بتحقيق الأهداف الموضوعية⁽¹⁾.

أما مفهوم الأداء الجيد في الأجهزة الأمنية، فهو يتمثل في "مدى المهارة في استغلال الموارد الأمنية من أفراد وأدوات ومركبات وأجهزة متنوعة، وذلك لتحقيق مستوى مرغوب من الامن من خلال الأداء في التوقيت المناسب وبالطريقة المناسبة، وبأقل التكاليف الممكنة في العنصر البشري والمادي"⁽²⁾.

ويُعد تقييم أداء العاملين ضرورة من ضرورات الإدارة الحديثة المتطورة، وذلك باعتبارها الوسيلة المثلى لتحقيق العدالة المهنية والوظيفية بين العاملين⁽³⁾.

إن معيار الأداء عبارة عن بيان مختصر يصف النتيجة النهائية التي يتوقع أن يصل إليها الموظف الذي يؤدي عمل معين، حيث يُعدُّ معيار الأداء الدستور أو القانون الداخلي المتفق عليه بين الرؤساء والمُؤوسين لتحديد الكيفية التي يتوصلوا بها إلى أفضل مستوى أداء⁽⁴⁾، وتتحصر أهم معايير الأداء في الأجهزة الحكومية فيما يلي:

أولاً: الجودة:

الجودة تحمل معاني كثيرة ومتعددة، فهي ذات معنى واقعي، ومعنى حسي، فالمعنى الواقعي يعني التزام المنظمات باستخدام مؤشرات حقيقية كمعدل الإنتاج، ونسبة الفاقد والهدر، ومن ثم استخدام معايير والتزام الأجهزة الأمنية بالموصفات والمقاييس المتعارف عليها، أما المعنى الحسي للجودة فإنه يركز على مشاعر وأحاسيس متلقي الخدمة والمستفيد منها (كمراجعي المرور والشرطة والدوريات الأمنية... الخ). بمعنى اقتناعهم ورضاهم عن الخدمات التي يقدمها جهاز الامن العام المتمثل في الإدارات المشار إليها آنفاً وغيرها من الإدارات الأخرى ذات العلاقة بالجمهور، وهل نجح العاملون في تقديم هذه الخدمات بمستوى جودة يناسب توقعاتهم ويلبي احتياجاتهم⁽¹⁾.

ثانياً: الكمية:

يُقصد بالكمية حجم العمل المنجز، وهذا يجب أن لا يتعدى قدرات وإمكانات الأفراد وفي الوقت نفسه لا يقل عن قدراتهم وإمكاناتهم، لأن ذلك يعني بطء الأداء، مما يصيب العاملين بالتراخي، وقد يؤدي إلى مشكلة في المستقبل تتمثل في عدم القدرة على زيادة معدلات الأداء. لذلك يفضل الاتفاق على حجم وكمية العمل المنجز كدافع لتحقيق معدل مقبول من النمو في معدل الأداء بما يتناسب مع ما يكتسبه الفرد من خبرات وتدريب وتسهيلات⁽²⁾.

ثالثاً: الوقت:

ترجع أهمية الوقت إلى كونه من الموارد غير القابلة للتجديد أو التعويض، فهو رأسمال وليس دخلاً، مما يحتم استغلاله الاستغلال الصحيح في كل لحظة من حياتنا، لأنه يتضاءل على الدوام ويمضي إلى غير رجعة، فالوقت أغلى من الذهب لأنه لا يُقدر بثمن، ويُعدُّ أحد خمس موارد أساسية في مجال إدارة الأعمال، وهي: الموارد، المعلومات، الأفراد، والموارد المالية بالإضافة إلى الوقت الذي يُعدُّ أكثر أهمية⁽¹⁾.

رابعاً: الإجراءات:

هي الخطوات التي يسير فيها أداء العمل، أو بمعنى آخر بيان توقعي للخطوات والإجراءات الضرورية الواجب إتباعها لتنفيذ مهام. لذلك يجب الاتفاق على الطرق والأساليب المسموح بها والمصرح باستخدامها لتحقيق الأهداف. وهذا لا يعني قتل عمليات الابتكار والإبداع لدى العاملين، ولكن الاتفاق والتفاهم على ما يريد المرؤوس تنفيذه مع رئيسه قبل اعتماده كأسلوب مفضل في إنجاز العمل ولضمان اتقاؤه وعدم مخالفته للنظم والتعليمات واللوائح والقوانين⁽²⁾.

وتتحصر أهم فوائد تقييم الأداء في الأجهزة الأمنية في رفع الروح المعنوية، وإشعار العاملين بمسؤولياتهم، والرقابة على الرؤساء، وتقييم سياسات الاختيار والتدريب⁽³⁾.

-
- (1) د. عصام فاعور ملكاوي: التخطيط الاستراتيجي كمؤشر لقياس الأداء الأمني، مرجع سابق، ص13.
(2) د. أحمد سيد مصطفى: قياس كفاءة تنفيذ العمليات الشرطية، مجلة الفكر الشرطي، العدد (1)، شرطة الشارقة، الشارقة، 1992م، ص123.
(3) عبد العزيز بن سعد القحطاني: فاعلية الحوافز المادية والمعنوية في تحسين أداء العاملين في سجون المنطقة الشرقية، رسالة ماجستير، جامعة نايف العربية للعلوم الأمنية، الرياض، 2009م، ص45.
(4) د. محمد عبد الغني حسن هلال: مهارة إدارة الأداء، مرجع سابق، ص95.
(1) المرجع السابق، ص5.
(2) المرجع السابق، ص100-101.
(1) د. عبد الرحمن بن محمد الجريسي: إدارة الوقت من منظور إسلامي، مكتبة العبيكان، الرياض، 2000م، ص9.
(2) د. محمد عبد الغني حسن هلال: مهارة إدارة الأداء، مرجع سابق، ص102.
(3) د. مهدي حسن زويلف: إدارة الأفراد "منظور كلي مقارن"، دار مجدلاوي للنشر والتوزيع، عمان، 1994م، ص289-291.

المطلب الثالث

محددات تقييم الأداء

ينطلب تحديد مستوى الأداء الفردي معرفة العوامل التي تحدد هذا المستوى والتفاعل بينها، ونظراً لتعدد هذه العوامل، وصعوبة درجة تأثير كل منها على الأداء، فإن الباحثين يواجهون عدة صعوبات في تحديد العوامل المؤثرة على الأداء ومدى التفاعل بينها. وضع "بورتر" و"الولر" نموذجاً نظرياً يقوم على مجموعة من الفروض حول محددات الأداء الوظيفي، تتكون من ثلاثة عوامل رئيسية، هي:

- 1- الجهد المبذول والذي يعكس درجة حماس الفرد لأداء العمل ودرجة دافعيته.
- 2- قدرات الفرد وخبراته السابقة التي تحدد درجة فاعلية الجهد المبذول ويشمل ذلك التعليم والتدريب والخبرات.
- 3- إدراك الفرد لدوره الوظيفي، ويشمل تصورات و انطباعاته عن السلوك والأنشطة التي يتكون منها، وعن الكيفية التي يمارس بها عمله في الجهاز الأمني⁽¹⁾.

ويرى البعض أن الأداء يتأثر بعوامل كثيرة بعضها يخضع للموظف وبعضها الآخر يعزى إلى الوظيفة، وبعضها يتأثر بالموقف. فالموظف وما يمتلكه من معرفة ومهارة ورغبة واهتمام وقيم ودوافع يُعدُّ محدداتاً رئيساً في تحديد مستوى الأداء. والوظيفة بما تتطلبه من مهام وواجبات وما تفرضه من تحديات، وما تقدمه من فرص للنمو الوظيفي تعد أيضاً محدداتاً رئيساً في تحديد مستوى الأداء. والموقف بما يتضمنه من بيئة تنظيمية وما توفره من موارد مادية وهيكل تنظيمي مرن أو جامد، وأساليب الوقاية وأنماط القيادة يُعدُّ محدداتاً رئيساً في تحديد مستوى الأداء⁽²⁾.

ويحدد آخرون العوامل المؤثرة في الأداء في متغيرين، هما: القدرة والدوافع المتوافرة لدى العامل، فأحياناً يمتلك العامل أفضل القدرات والمهارات ولكنها دون جدوى دون توافر الدافعية للعمل، والعكس صحيح، فقد يتوافر لدى العامل الدافع القوي للعمل، ولكن دون قدرة على العمل سوف ينعدم توافر العلاقة بين الدافع والقدرة والأداء⁽¹⁾.

ونظراً لصعوبة اتفاق علماء الإدارة على محددات الأداء، فإنهم يحذرون من تعميم النتائج التي تصل إليها بعض الدراسات التالية:

- 1- إن أداء فئة معينة من العاملين ليست هي محددات أداء فئة أخرى.
- 2- أن محددات أداء الأفراد العاملين في منظمة ليست بالضرورة نفسها محددات أداء الأفراد العاملين في منظمة أخرى.
- 3- إن العوامل البيئية الخارجية لها أثر في تحديد محددات الأداء.

إن عملية تقييم الأداء شأنها شأن أي عمل إداري آخر، تقوم على معايير تعرف سلفاً، ويحدد فيها مستوى أداء الموارد البشرية المطلوب، والواجب توافره في العمل الذي تقوم به هذه الموارد البشرية داخل المنظمات، وعلى أساس هذه المعايير تستطيع إدارة الموارد البشرية بالتعاون مع الإدارات الأخرى داخل المنظمة تحديد ما إذا كان أداء الموارد البشرية محل التقييم مطابقاً للمعايير السابق وضعها أو مغايراً لها.

وعملية تقييم الإدارة هي عملية إدارية للحكم على مدى تقدم هذا الموظف أو ذاك قياساً إلى واجباته وسلوكياته، في فترة زمنية معينة لا تزيد عن سنة، ويصدر عن هذه العملية تقريراً في شكل نموذج معين يوضع في ملف العامل أو الموظف، وينتج آثاره الإدارية والقانونية⁽²⁾.

الخاتمة

تناولنا في هذا البحث الاستفادة من مبادئ التخطيط الاستراتيجي في الفكر الإسلامي لتفعيل الأداء الوظيفي، وقد اتضح لنا أن عصرنا الحالي يشهد متغيرات متسارعة ومركبة في مختلف مناحي الحياة على جميع المستويات نتيجة تأثير العولمة والتطورات الكبيرة والمستمرة على المستوى العلمي والتقني، الأمر الذي حتم على المنظمات الحكومية والخاصة على حد سواء العمل على تغيير الاستراتيجيات والسياسات بشكل دائم لكي تستطيع التكيف مع هذه التطورات، لذلك برزت الحاجة لوجود أداة جديدة متمثلة بالتخطيط الاستراتيجي كأحد أهم الأدوات الإدارية المتميزة بوصفه منهجاً يسهل بالمنظمة لتحقيق ما تصبو إليه بكفاءة وفاعلية، وقد ارتبط مفهوم التخطيط الاستراتيجي في الإسلام بمفهوم الكفاءة، فمن مبادئ التنظيم المهمة مبدأ وحدة الأمر، والذي يقصد به ألا يتلقى المرءوس أو امر إلا من رئيس واحد فقط. كما تطرقنا إلى مبدأ تكافؤ السلطة والمسئولية وهو الذي ينطلق من قاعدة شرعية عربية، مؤداها: أن يكون التكليف على قدر الوسع (لا يُكَلِّفُ اللَّهُ نَفْسًا إِلَّا وُسْعَهَا لَهَا مَا كَسَبَتْ وَعَلَيْهَا مَا اكْتَسَبَتْ رَبَّنَا لَا تُؤَاخِذْنَا إِنْ نَسِينَا أَوْ أَخْطَأْنَا رَبَّنَا وَلَا تَحْمِلْ عَلَيْنَا إصْرًا كَمَا حَمَلْتَهُ عَلَى الَّذِينَ مِنْ قَبْلِنَا رَبَّنَا وَلَا تُحَمِّلْنَا مَا لَا طَاقَةَ لَنَا بِهِ وَاعْفُ عَنَّا وَارْحَمْنَا أَنْتَ مَوْلَانَا فَانصُرْنَا

(1) د. عبد الرحمن بن محمد الجريسي: إدارة الوقت من منظور إسلامي، مرجع سابق، ص 121.

(2) د. محمود مرسي ود. زهير الصباغ: إدارة الأداء، معهد الإدارة العامة، الرياض، 1988م، ص 28.

(1) د. سعيد يسن عامر، ود. خالد يوسف الخلف: الإنتاجية القياسية "معايير الأداء الوظيفي - قياس الأداء الوظيفي"، دار المريخ، الرياض، 1983م، ص 63.

(2) د. عبد الحكيم أحمد الخزامي: تكنولوجيا الأداء من التقييم إلى التحسين "تقييم الأداء"، مرجع سابق، ص 21.

على القوم الكافرين) ؛ وذلك بالأ يتم تحميل أحد الأفراد مسئولية، دون منحه سلطة متكافئة تمكنه من أدائها. ولعل ما نلاحظه من السعي لكل شيء في الحياة، والحركة لتهدئة المهام المنوطة على خير وجه -ينم عن توافر قدر كبير من السلطة، والصلاحية المكافئة والممنوحة للأشياء.

وقد حظى مبدأ المشورة بمكانة عظيمة في التشريع الإسلامي، وأصبحت من المبادئ التي يقوم عليها نظام الحكم والإدارة في الدولة الإسلامية في مختلف العصور، ومما يؤكد ذلك: أن الله تعالى أوجب الرجوع إلى الأمة والجماعة عند اتخاذ القرارات المهمة، قال تعالى: (فَبِمَا رَحْمَةٍ مِنَ اللَّهِ لِنْتَ لَهُمْ وَلَوْ كُنْتَ فَظًا غَلِيظَ الْقَلْبِ لَانفَضُّوا مِنْ حَوْلِكَ فَاعْفُ عَنْهُمْ وَاسْتَغْفِرْ لَهُمْ وَشَاوِرْهُمْ فِي الْأَمْرِ فَإِذَا عَزَمْتَ فَتَوَكَّلْ عَلَى اللَّهِ إِنَّ اللَّهَ يُحِبُّ الْمُتَوَكِّلِينَ).

كما حيث جاء الإسلام بمبدأ المساواة، وكان بذلك أسبق -في هذا المقام- مما يعرف من التشريعات في العصر الحديث، وفي الآيات القرآنية التي تدعو إلى المساواة قوله تعالى: (إِنَّمَا الْمُؤْمِنُونَ إِخْوَةٌ فَأَصْلِحُوا بَيْنَ أَخَوَيْكُمْ وَاتَّقُوا اللَّهَ لَعَلَّكُمْ تُرْحَمُونَ).

ولقد طبقت الإدارة في الإسلام مبدأ الكفاءة، والجدارة، والأمانة، والقدرة على الأداء والعمل، وتولية الوظائف العامة قبل أن تأخذ به النظم الإدارية الحديثة، ومعنى ذلك: أن الإدارة الإسلامية ربطت بين السلوك التنظيمي وبين الإنتاج في العمل، وقد التزمت الإدارة الإسلامية بما جاء في القرآن الكريم والسنة النبوية الشريفة، فقد قال تعالى: (قَالَتْ إِحْدَاهُمَا يَا أَبَتِ اسْتَأْجِرْهُ إِنَّ خَيْرَ مَنِ اسْتَأْجَرْتَ الْقَوِيُّ الْأَمِينُ).

وقد اوضح لنا ان الإدارة التربوية الإسلامية تستند على التعاون والمشورة الصادقة المخلصة، وعلى العدل والمساواة، وعمادها الشعور بالمسؤولية لدى كل فرد في حدود مسؤولياته، وميزتها عن غيرها أنها لا تسعى لتحقيق الأهداف الدنيوية فحسب؛ بل تسعى لتحقيق الفلاح في الآخرة كذلك.

يفهم عدد من علماء الإدارة مدلول الكفاءة على أنه الفاعلية، ويشير إلى أداء الأشياء الصحيحة (لكونها تتصل بالاهداف)، أما الكفاءة فهي أداء الأشياء بطريقة صحيحة (فهي أكثر اتصالاً بكيفية أداء الأعمال)، حيث يعبر الأداء عما يتمتع به العاملون في المنظمات الإدارية بصفة عامة والمنظمات الأمنية بصفة خاصة من مهارات وقدرات وإمكانات اتصالية، فإذا كان الأداء مناسباً للعمل المطلوب إنجاز، فإنه يحقق الغرض منه، أما إذا كان الأداء لا يرقى إلى المستوى المطلوب لإنجاز العمل، فإن ذلك يتطلب تطوير وسائل الاتصالات المستخدمة لرفع كفاءة العاملين وتحسين أدائهم بهدف الوصول إلى المستوى المطلوب من الأداء. حيث تؤثر الاتصالات بشكل فعال على الأداء، لأن الاتصالات هي التي يتم من خلالها نقل التعليمات والأوامر، وكذا استفسارات العاملين سواء من الرؤساء في المستويات الإدارية العليا، أو من الزملاء في نفس المستويات الإدارية عن كيفية أداء بعض الأعمال والمهام، أو مواجهة بعض المشكلات التي تعترض أدائهم.

قائمة المصادر والمراجع

- (1) أحمد سيد مصطفى: قياس كفاءة تنفيذ العمليات الشرطية، مجلة الفكر الشرطي، العدد (1)، شرطة الشارقة، الشارقة، 1992م.
- (2) البلازي، أحمد بن يحيى: فتوح البلدان، الجزء الأول.
- (3) الخزامي، عبد الحكيم أحمد: تكنولوجيا الأداء من التقييم إلى التحسين "تقييم الأداء"، الجزء الثاني، مكتبة ابن سينا، القاهرة، 1999م.
- (4) الدجني، إياد علي (2010-2011). دور التخطيط الاستراتيجي في جودة الأداء المؤسسي "دراسة وصفية تحليلية في الجامعات النظامية الفلسطينية"، رسالة دكتوراه في التربية، جامعة دمشق.
- (5) الددا، مروان سليمان سالم: فعالية برنامج مقترح لزيادة الكفاءة الاجتماعية للطلاب الخجولين في مرحلة التعليم الأساسي، رسالة ماجستير في علم النفس، كلية التربية، الجامعة الإسلامية، غزة، يناير 2008م.
- (6) درة، عبد الباري إبراهيم: تكنولوجيا الأداء البشري، مهارة أساسية من مهارات القيادات في المؤسسات الشرطية العربية، ورقة عمل مقدمة إلى الحلقة العلمية للمهارات الإدارية العليا المنعقدة بالطائف، جامعة نايف العربية للعلوم الأمنية، الرياض، 1998م.
- (7) الزهراني: مسفر: إستراتيجيات الكشف عن الموهوبين والمبدعين ورعايتهم بين الاصلالة المعاصرة، دار طيبة، مكة المكرمة، 1424 هـ.
- (8) سعيد يسن عامر، ود. خالد يوسف الخلف: الإنتاجية القياسية "معايير الأداء الوظيفي - قياس الأداء الوظيفي"، دار المريخ، الرياض، 1983م.
- (9) ضرار، قاسم: تنمية المهارات الإشرافية على المستوى التنفيذي الأول، دراسة وصفية تحليلية لمهام وتحديات الإشراف في المنظمات الإدارية، معهد الإدارة العامة، الرياض، 1999م.
- (10) عبد الرحمن بن محمد الجريسي: إدارة الوقت من منظور إسلامي، مكتبة العبيكان، الرياض، 2000م.
- (11) عبد العزيز بن سعد القحطاني: فاعلية الحوافز المادية والمعنوية في تحسين أداء العاملين في سجون المنطقة الشرقية، رسالة ماجستير، جامعة نايف العربية للعلوم الأمنية، الرياض، 2009م.
- (12) علاقي، مدني عبد القادر: إدارة الموارد البشرية "المنهج الحديث في إدارة الافراد"، مكتبة دار زهران للنشر والتوزيع، جدة، 1993م.

- (13) عمار، حامد: مواجهة العولمة في التعليم والثقافة، الهيئة المصرية العامة للكتاب، مكتبة الأسرة، 2006م.
- (14) عيسى، حمد علي عبد الله: تأثير المناخ التنظيمي على الأداء الوظيفي للعاملين "دراسة ميدانية على إدارة المنافذ بشؤون الجنسية والجوازات"، رسالة ماجستير، كلية العلوم الإدارية، جامعة العلوم التطبيقية، مملكة البحرين، 2014م.
- (15) القريطي، عبد المطالب: الموهوبون والمتفوقون خصائصهم واكتشافهم ورعايتهم، ط1، دار الفكر العربي، ط1، 2005م.
- (16) محمود مرسي وزهير الصباغ: إدارة الأداء، معهد الإدارة العامة، الرياض، 1988م.
- (17) المطيري، تركي سلطان: تقييم كفاءة الموظف العام في قانون الخدمة المدنية الكويتي، مجلة الشريعة والقانون، السنة السابعة والعشرون، العدد الثالث والخمسون، جامعة الإمارات العربية المتحدة، العين، 2013م.
- (18) مهدي حسن زويلف: إدارة الأفراد "منظور كلي مقارن"، دار مجدلاوي للنشر والتوزيع، عمان، 1994م.
- (19) هلال، فراس عصمت (2015-2016). تأثير التخطيط الاستراتيجي في أداء المنظمات "حالة وزارة التعليم العالي نموذجاً"، رسالة ماجستير في إدارة الأعمال، الجامعة الافتراضية السورية، دمشق.
- (20) هلال، محمد عبد الغني حسن: مهارة إدارة الأداء، ط2، مركز تطوير الأداء والتنمية، القاهرة، 1999م.

THE CONCEPT OF INNOVATION IN ISLAM AND THE METHODOLOGY OF ITS ADMINISTRATION IN CONTEMPORARY INSTITUTIONS

Badr Alhosani

المخلص

مفهوم الابتكار في الإسلام ومنهجية إدارته في المؤسسات المعاصرة

إن الإسلام شرع للإبتكار من خلال الاجتهاد والإبداع الفكري، وأنه يمنع من الجمود والتقليد الأعمى غير المبني على الحجج والبراهين، قد شرع الإسلام للاجتهد والابتكار لمواكبة مستجدات الحياة المعاصرة باعتبارها صالحاً لكل زمان ومكان من خلال الموازنة بين ثبات النصوص الشرعية وقيمتها، وبين الحاجة إلى الابتكار والتجديد لتلبية الاحتياجات المتنوعة في كل الأزمنة والعصور.

وقد أثبتت الدراسات المتخصصة أن الاجتهاد والابتكار الفكري من أصول الدين، وأن علماء الإسلام في الأزمنة المعاصرة قادرين على تقديم الحلول العلمية لمشكلات العالم المعاصر استناداً إلى منهج أسلافهم، إذا استوعبوا تاريخهم وسلوكوا طريقهم، كما أثبتت الفضل الكبير للحضرة الإسلامية على حضارة العالم شرقاً وغرباً ابتداءً من القيم والأخلاق، ومروراً باللغة والأدب، وانتهاءً بالعلوم التطبيقية والاختراعات المعاصرة.

إن للإبتكار مجالات شتى في جميع مرافق الحياة، فكما يكون في البرمجيات والميكانيكا والاتصال والفضاء والنفاه؛ يكون كذلك في النظم الإدارية وإسعاد الناس وإخراجهم من الأساليب العقيمة المعقدة التي لا معنى لها إلا ضياع الوقت والجهد، والتي يؤسف أنها لاتزال في بعض المؤسسات الحكومية.

إن الإمارات لديها قيادة حكيمة تؤمن بأن الابتكار هو رأس مال المستقبل وبأن بناء الإنسان يأتي قبل رفع البنيان، ولذلك فهي تؤمن بأن العلم والمعرفة هي أهم أصولها وبأن إبداع الإنسان هو سر حضارتها وبأن الانفتاح على جميع حضارات العالم هو مفتاح قوتها. وقد جعلت دولة الإمارات جعلت من الابتكار قيمة مضافة لها وزنها في الاقتصاد الوطني وفي المجتمع ككل، حيث أن الابتكار لم يعد خياراً، وإنما هو ضرورة للول والمجتمعات والشعوب الساعية لتعزيز موقعها على خريطة العالم الاقتصادية وتقوية تنافسيتها. ولذلك فإن الإمارات وضعت الابتكار أحد المحاور الأساسية لرؤيتها 2021. إن الميزانية الضخمة التي أعلن عنها صاحب السمو الشيخ محمد بن راشد للإبتكار، تؤكد عبقرية هذا القائد في جعل الابتكار نمط حياة، فلم يبق عنراً لما كان يتردد من عدم وجود ميزانية كافية للبحث العلمي مقارنة بما تبذله الدول المتقدمة في هذا المجال، فهذا هي الميزة الوفيرة، والتوجه السياسي الرسمي، والتفاعل الكبير من كل المؤسسات الحكومية والخاصة، فلم يبق إلا الجهد الذاتي من الناس على اختلاف تخصصاتهم، فعلى كل واحد أن لا يستقل نفسه، فلعله يوجد بفكرة تكون سبباً لنفع كبير.

Abstract

Islam has legalized innovation through intellectual diligence and creativity, and it prevents rigidity and blind imitation that is not based on arguments and proofs. Islam has legalized for ijtihad and innovation to keep pace with the developments of contemporary life as it is good for every time and place by balancing the stability and sanctity of legal texts, and the need for innovation and renewal to meet the diverse needs of all times and ages. Specialized studies have proven that diligence and intellectual innovation are the origins of religion, and that the scholars of Islam in contemporary times are able to provide scientific solutions to the problems of the contemporary world based on the approach of their predecessors, if they absorbed their history and followed their path, as it proved the great merit of Islamic civilization over the civilization of the world east and west starting from values and ethics, passing through language and literature, and ending with applied science and contemporary inventions. Innovation has various fields in all facilities of life, as it is in software, mechanics, communication, space and defense; It is the same in administrative systems, making people happy, and removing them from sterile, complex methods that have no meaning except waste of time and effort, which is unfortunately still in some governmental institutions. The Emirates has a wise leadership that believes that innovation is the capital of the future and that building the human comes before lifting the structure, and therefore it believes that science and knowledge are the most important assets and that human creativity is the secret of their civilization and that openness to all civilizations of the world is the key to its strength. The UAE has made innovation an added value that has its weight in the national economy and in society as a whole, as innovation is no longer an option, but rather a necessity for countries, societies and peoples seeking to enhance their position on the world economic map and strengthen their competitiveness. Therefore, the UAE has put innovation as one of the main axes of its vision 2021. The huge budget announced by His Highness Sheikh Mohammed bin Rashid for innovation confirms the genius of this leader in making innovation a life style, so he did not remain an excuse for what was rumored of not having a sufficient budget for scientific research compared to what the developed countries exert it in this field, as it is the abundant budget, the official political orientation, and the great interaction of all governmental and private institutions, so only the self-effort of people of different specialties remains, so that each one does not resign himself, so perhaps he finds an idea that is a reason for great benefit.

مقدمة

يُعدُّ الابتكار الإداري من أهم القدرات التي يجب أن تحظى بالاهتمام والعناية والرعاية، وفي الوقت الراهن أصبح الاهتمام بالابتكار بوجه عام والابتكار الاقتصادي بوجه خاص ضرورة تحتمها طبيعة العصر الحديث كونه يدخل ضمن كافة مجالات الحياة.

ويُعدُّ الابتكار الاقتصادي وسيلة لتوظيف المعرفة والمهارة للإتيان بما هو جديد، لأننا نعيش في عصر اقتصاديات المعرفة المعتمدة على الابتكار الذي يدفع الإنسان ويحفزه للتنفيذ النابع من سلوك إنساني والعمل الجاد.

إن الابتكار هو تحول الفكرة من مشروع نظري إلى منتج أو خدمة تؤدي منفعة اجتماعية أو مادية، وتتضمن هذه العملية تحويل بذرة الفكرة إلى فكرة نافعة ومن ثم إلى مشروع، وبناءً على هذا المبدأ، دشّن صاحب السمو الشيخ محمد بن راشد آل مكتوم، نائب رئيس الدولة رئيس مجلس الوزراء لدولة الإمارات العربية المتحدة الاستراتيجية الوطنية للابتكار بمخطّط زمني يمتد لسبعة أعوام يبدأ من عام 2014م حتى عام 2021م، والتي تهدف إلى جعل دولة الإمارات في مقدمة الدول الأكثر ابتكاراً في العالم.

إن النجاح في مجال الأعمال في يومنا هذا يتطلب الابتكار الاقتصادي، فالمؤسسات التي تبتكر تجني كل المزايا وذلك بالفعل التنافسي، فيكون الابتكار الاقتصادي مصدراً أساسياً لتنمية الإيرادات وللنجاح في البيئة التنافسية الحالية، وذلك من خلال تأثيره على الإنسان، وجعله يكتسب معرف جديدة تمكنه من التحكم في بيئته، وتجعله يتأثر ويؤثر فيها. ومن بين هذه الابتكارات نجد الابتكار الاقتصادي الذي أصبح يمثل في العصر الحالي أحد أهم العوامل التي يتوقف عليها نجاح المؤسسات في تنمية إيراداتها، والذي يأخذ شكل منتجات جديدة وطرق إنتاجية جديدة، وتطبيق الابتكار الاقتصادي في المؤسسات مهما كان حجمها يؤدي إلى رصد وجمع الأفكار والمعارف المتاحة، واستغلالها في تطوير المجال الإنتاجي للمؤسسة، وكسب مزايا تنافسية مستمرة وكذا التأقلم والتكيف مع متغيرات البيئة.

ويعتبر الابتكار الاقتصادي منظومة متكاملة يشترك فيها أفراد المنظمات من مدراء ماليين وموظفين، وكذلك بيئة المنظمة، وتعتبر الإدارة بما فيها من موظفين العنصر الأساسي في العملية الابتكارية.

كما يُعدُّ الابتكار الاقتصادي من المواضيع المهمة والحديثة في العلوم الإدارية، وقد غدا من أهم مقومات التنمية والتطوير للأفراد والمؤسسات على السواء، إذ له دور هام في بقاء المؤسسة وتطورها، حيث أن المؤسسة التي لا تبتكر ولا تتطور يكون مصيرها التراجع والاضمحلال بل قد يكون الزوال.

يساعد الابتكار الاقتصادي المؤسسات على تنمية الإيرادات من خلال التكيف مع التغيرات المتلاحقة ويساعدها على مواجهة التحديات المتعددة والمختلفة، وبالتالي تحقيق الميزة التنافسية التي تسعى المؤسسة إلى تحقيقها، فالابتكار الاقتصادي يقود إلى التجديد، والتجديد يجعلنا نتقدم على غيرنا.

وبالنظر إلى الموضوع الذي سيتم معالجته وطبيعة المعلومات المتوفرة عنه، وطريقة تحليلها يفرض استخدام منهجية معين لمثل هذه الدراسة يمكننا من بيان مفهوم الابتكار في المؤسسات المعاصرة، وكذلك الابتكار من الإسلام، عن طريق اعتماد المنهج الوصفي وبناءً عليه نستخلص التوصيات، هذا المنهج يتناسب وطبيعة موضوع البحث، إذ يعتمد عادةً في دراسة الظواهر الإنسانية لوصف خصائصها بدقة، وقد تم اعتماده في الجانب النظري لإبراز التعريف والمفاهيم المرتبطة بهذا الجانب، وذلك من خلال تقسيم البحث على النحو التالي:

المبحث الأول

مفهوم الابتكار في المؤسسات المعاصرة

تمهيد وتقسيم:

الابتكار الاقتصادي هو المقدر على تطوير فكرة أو عمل أو تصميم أو أسلوب أو أي شيء آخر وبطريقة أفضل وأيسر وأكثر استخداماً وجدياً، وهناك ليس كبير بين الابتكار والإختراع عند عموم الناس (هندي، 2003م، ص 631)؛ فالابتكار هو ما أشرنا له سابقاً أما الإختراع فهو إيجاد الفكرة أو التصميم أو الأسلوب من العدم، بحيث أنه لم يكن له مثيل من قبل وليس شرطاً أن يكون الإختراع قابلاً للتنفيذ، فإذا ما عدل عليها وأضيف لها تحسينات تسمى هذه الإضافات بالابتكار (الحناوي، العبد، ص 369).

ويرى الباحث أن الابتكار الاقتصادي يمكن الاستفادة منه في زيادة إيرادات المؤسسة، حيث تقوم المؤسسة بابتكار فكرة، يتم تحويل هذه الفكرة إلى نظام عمل أو سلعة أو اختراع، ومن ثم فإن احتكار هذه الفكرة وما ينتج عنها من إنجازات مادية يعود بلا شك بالنفع على المؤسسة متمثلاً في زيادة الإيرادات.

وللتعرف على مفهوم الابتكار الاقتصادي، سيتم تقسيم هذا المبحث إلى ثلاثة مطالب، وذلك على النحو التالي:

- المطلب الأول: تعريف الابتكار الاقتصادي.
- المطلب الثاني: خصائص الابتكار الاقتصادي وعناصره.
- المطلب الثالث: طرق اللجوء إلى الابتكار الاقتصادي.

المطلب الأول

تعريف الابتكار الاقتصادي

يعرف الابتكار بوجه عام في قاموس (1) Good على أنه: "تفكير المبتكر الذي يكشف حالات جديدة أو الوصول إلى حلول للمشكلات القيمة، وتؤدي إلى أفكار أصيلة متزامنة مع الفكر" (التنقيتات، 2006م، ص 20).

ويرى الباحث أن هذا التعريف يُحمد له أنه اعتبر الابتكار فكر جديد يتم الاعتماد عليه في حل المشكلات، ولكنه لم يوضح كيفية الاستفادة من هذه الفكرة لتحويلها إلى خدمات أو سلع ملموسة يمكن أن تستفيد منها المؤسسة المبتكرة على المستوى المالي.

والابتكار الاقتصادي هو الإتيان بالجديد في المجال المالي. ولأن الإدارة المالية نشاط واعي هادف (R. A. Gorman, 2004, p.140)، فإن هذا الجديد بوجهه نحو تحقيق: الاستجابة الأفضل لخدمات ومنتجات المنظمة وحاجات عملائها الداخليين والخارجيين، وزيادة الأداء بشكل جذري أو

(1) good هو قاموس أمريكي مشهور مختص في التعريفات العلمية ويتميز باختصاره للتعريفات، ويحتوي على أكثر من 125 ألف كلمة وعبارة.

تدريجياً كما في مفاهيم إعادة الهندسة والتحسين المستمر (حنفي، 1995م، ص357)، وتحسين طرق العمل (كما في دراسة العمل والحركة)، وتحسين علاقات العمل في المنظمة داخلياً (كما في مفاهيم العمل الجماعي والفرق المُدارة ذاتياً)، وتعزيز علاقات المنظمة مع بيئتها الخارجية (كما في مفاهيم المسؤولية الاجتماعية وأخلاقيات الإدارة)، ومراجعة أفضل لمطالب مصالح أصحاب المصلحة والصالح العام (مجلس التجارة والتنمية، 2013م، ص36).

ويرى الباحث أن هذا التعريف على الرغم من تفصيله وتوضيحه لمفهوم الجديد في عالم الابتكار الاقتصادي، وخاصة فيما يتعلق بتفعيل أداء المؤسسة، ولكنه لم يوضح مدى انعكاس هذا الفكر الجديد على الجانب المالي للمؤسسة صاحبة الابتكار.

ومن جهة أخرى، يرى بعض الباحثين أن الابتكار يفهم من خلال التغيير، بمعنى آخر، الابتكار الاقتصادي يعني التغيير، لأن إدارة التغيير تعرف بالإدارة التي تجري تعديلاً واضحاً أو أجزاء مختلفة من واقعها الحالي. إذن الإبداع يعتبر مدخلاً للابتكار المالي والتطبيق العملي له (Joan Pynes, 2004, p.58) ونخلص إلى التمييز بدقة متناهية بين الإبداع والابتكار الاقتصادي؛ الإبداع يتعلق بتأليف الأفكار وتوليدها، والابتكار الاقتصادي يتعلق بتطبيق الأفكار وتحويلها إلى واقع عملي ملموس (الحسنية، 2009م، ص5).

ويرى الباحث أن هذا المفهوم لا يقدم جديداً في مجال الابتكار الاقتصادي، لأنه اعتبر الابتكار الاقتصادي هو التغيير في حد ذاته، ونحن بدورنا نرى أن هذا التغيير قد يكون تغييراً إيجابياً أو سلبياً، فإن كان التغيير سلبياً فإن هذا لا يُعد ابتكاراً مالياً بالمعنى المقصود.

ويمكن توضيح مفهوم الابتكار الاقتصادي وتمييزه عن الإبداع عن طريق الشكل رقم (1) التالي:

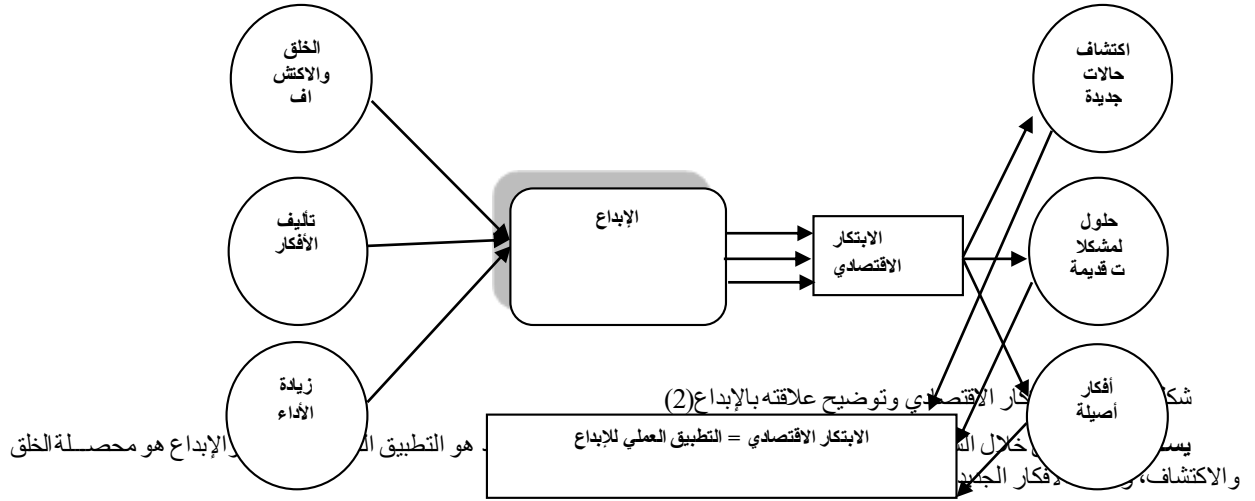

وقد أبدى بعض الباحثين فروقات بين الإبداع والابتكار الاقتصادي، فالإبداع يركز على درجة الخلق والاكتشاف للمدخلات، واعتبار هذه المدخلات جديدة من منظور مبدعها أو جمهور ناظرها، في حين يعد الابتكار الاقتصادي عملية التمسك بفكرة مبدعة وتحويلها إلى سلعة أو خدمة نافعة أو إلى طريقة عمل مفيدة، أي هو التطبيق العملي للإبداع، بمعنى المؤسسة المبتكرة مالياً هي المؤسسة التي تحول الأفكار المبدعة إلى مخرجات نافعة (بلوط، 2005م، ص358-359).

ونظراً لأهمية هذا التعريف، سيعتمد عليه الباحث كتعريف إجرائي للابتكار المالي في هذا البحث، حيث يتضح لنا من خلال هذا التعريف أنه اعتبر الابتكار هو التحول من فكرة معنوية إلى سلعة مادية أو خدمة نافعة، يمكن أن تدر وأردات للمؤسسة صاحبة الفكرة.

المطلب الثاني

خصائص الابتكار الاقتصادي وعناصره

يؤدي الابتكار الاقتصادي إلى منتج جديد ليس مجرد وهم، وجديد لا يعني أنه اكتشاف، ولكن تكميل على من بدأ، أو تعديل في شيء، أو تغيير في أسلوب الأداء فهو (الترام) (Al-Jalal Ibrahim & Kurdi, Manal Mohamed, 2000, p.46)، وهو ليس اختراعاً، فعندما يقوم أحد الباحثين بابتكار فكرة، ويتم استغلال هذه الفكرة من قبل المؤسسة التي يعمل بها، وتستطيع المؤسسة تحويل هذه الفكرة إلى منتج جيد أو خدمة متميزة، فإن ذلك يُعد من قبيل الاكتشاف وليس اختراعاً. وعندما سُئل أحد النحاتين: كيف يبدع هذه النماذج المنقطة؟ قال: إنني لا أخلق من عدم، ولكنني أكتشف ما هو موجود أصلاً (الباز، 2003م، ص35-36).

فالابتكار الاقتصادي ليس خلقاً، وإنما اكتشاف منتج جديد. إذن، الابتكار الاقتصادي عملية عقلية، وأساسها الإحساس بالمشكلة (K. Murphy, 2005, p.67).

(2) الشكل من اجتهاد الباحث.

وفي هذا السياق فإن الابتكار الاقتصادي هو التوصل إلى المفاهيم الجديدة القابلة للتحويل إلى سياسات وتنظيمات وطرق جديدة تساهم في تطوير الأداء المالي في المنظمة. بل إن بعض هذه المفاهيم يتعلق بتطوير عملية الابتكار الاقتصادي وتنظيمها، وإجراءات نقل الأفكار الجديدة إلى منتجات جديدة، والتميز والتفرد فيها (Borins, S., 1995, p.218).

فالهدف النهائي لهذا الابتكار يتمثل في تحويل الفكرة إلى واقع ملموس سواء في إنتاج سلعة جديدة، أو خدمة مميزة. وهذا ما يمكن أن نجمله بالتأكيد على أن الابتكار الاقتصادي هو في هدفه الأخير ونتاجه الحقيقي الأكثر أهمية يتمثل في ابتكار الإنتاجية أي: الابتكار الاقتصادي = ابتكار الإنتاجية (جودة، 2008م، ص99).

أولاً: خصائص الابتكار الاقتصادي:

نظراً للمكانة التي يبرزها الابتكار الاقتصادي، خاصة في تحقيق الميزة التنافسية، نجد أنه يتمتع بمجموعة من الخصائص، وفيما يلي نستعرض أهمها على النحو التالي:

1. هو عبارة عن عملية إنتاج، حيث تظهر العملية الابتكارية من خلال القدرات التفكيرية لدى الأفراد، أما الإنتاج الابتكاري فيظهر من خلال الأفكار أو السلوكيات أو الأشياء المادية (M. Howlett and J. Rayner, 2006, p.260)، ويرى الباحث من أمثلة ذلك عندما يقوم أحد الباحثين العاملين في مؤسسة تعمل في مجال صناعة وإنتاج الأدوية، باكتشاف فكرة جديدة، ويقوم باختبار هذه الفكرة ويثبت بالتجربة العلمية مدى نجاحها، فإن الشركة ستقوم بتصنيع دواء جديد، ويتم طرحه في الأسواق، مما يدر المزيد من الدخل لهذه الشركة، وبذلك تكون قد تحوَّبت الفكرة إلى منتج ملموس هو الدواء.
2. إن العملية الابتكارية لا تحدث فجأة، وإنما تمر بعدة مراحل (الحبيشي، 2008م، ص58)، ويرى الباحث أن العملية الابتكارية تحتاج إلى تجارب عملية ودراسات مستفيضة لكي يتم الاقتناع من جدوى الفكرة، ومدى الاستفادة منها في حالة تحولها إلى منتج ملموس أو خدمة متميزة.
3. إن الابتكار الاقتصادي هو قدرة عقلية من الممكن أن تظهر على مستوى الفرد، والجماعة أو المنظمة، حيث تمثل هذه القدرات المحاور الأساسية للابتكار المالي (حريم، 2013م، ص14)، وهنا يرى الباحث أن هذه الفكرة التي تُعدُّ محور الابتكار وبذرتة الأولى قد تكون من إنتاج أو اكتشاف فرد واحد في المؤسسة، وقد تكون من اكتشاف فريق عمل مثل مجموعة من الباحثين أو الإداريين أو المديرين الذين يسعون إلى تطوير المؤسسة التي يعملون بها.
4. إن الابتكار الاقتصادي ظاهرة إنسانية عامة وليست ظاهرة خاصة، فالابتكار الاقتصادي ليس حكراً على العلماء والخبراء، بل هو متاح لكل إنسان عاقل سواء كان مبتكراً أم لا (R. A. Gorman, 2004, p.129)، ويرى الباحث أن الابتكار الاقتصادي ليس حكراً على أشخاص معينين أو على جنسيات محددة أو دول، ولكن الابتكار الاقتصادي متاح لكل بني البشر، وهو من القدرات التي أودعها الإنسان في عقل الإنسان، ويمكن عن طريقها بناء الحضارات والمساهمة في تطوير الثقافات، والهدف النهائي في إسعاد البشر وجعل الحياة أكثر سهولة وأكثر تقدماً.
5. يعتمد الابتكار الاقتصادي على التفكير المتعمق الشمولي الذي يبحث المشكلة من جميع جوانبها، ويوجد عدة حلول مكافئة لها (محمد، 2016م، ص3)، ويرى الباحث أن هذا التفكير الشمولي لا بد أن يراعي كافة جوانب المؤسسة المبتكرة، بما فيها من موارد بشرية وموارد مادية، ولا بد أن يجيب عن عدد من التساؤلات المطروحة ويثبت نجاحه في مرحلة التجربة، حتى يمكن الاستفادة من هذا الابتكار الاقتصادي على أرض الواقع.
6. يتضمن الابتكار الاقتصادي النظر إلى الأمور من زوايا مختلفة قد لا يراها سوى المبتكرون (M. Howlett and J. Rayner, 2006, p.58)، ويرى الباحث أن النظر إلى الأمور من زوايا مختلفة تعني التفكير خارج الصندوق، أي التفكير بشكل حديث بعيداً عن التفكير التقليدي، ومن ثم سوف يكون الناتج أيضاً مختلفاً.
7. الابتكارات المالية الفعالة تبدأ دائماً صغيرة، ثم يتطور الأمر حالياً وفقاً لنتائج التقويم والتجريب (حسن، 1998م، ص90)، ويرى الباحث أن هذه الخاصية قد تكون هي الخاصية المميزة لكافة أنواع الفكر، فالفكر الذي يؤدي إلى الابتكار الاقتصادي هو فكر إنساني، يكون قابلاً للتراكمية، فقد تكون فكرة بسيطة، ويقدم لها آخرون أفكاراً أخرى تدعمها، حتى تصبح فكرة ذات شأن كبير، ويمكن تطبيقها في الواقع العملي، وتحويلها إلى سلعة مميزة أو خدمة مستحدثة، تزيد من إيرادات المؤسسة.
8. لا يفكر المبتكر مالياً في حل جديد فحسب، بل يدرك وجود مشكلات جديدة وينظر إلى المألوف والشائع من خلال منظور جديد (G. Handl, 2005, p.44)، ويرى الباحث أن النظر إلى المشكلة من منظور جديد هو الإجراء الذي من شأنه اكتشاف حلول جديدة لم يكن متعارف عليها من قبل، ومن ثم فإن الحلول التي سيتم التوصل إليها ستكون حلولاً مبتكرة ويمكن الاستفادة منها مالياً في المؤسسة صاحبة الفكرة.
9. الابتكار الاقتصادي علم نظري تجريبي قابل للتغيير والتبديل باختلاف الزمان والمكان، فبعض ما هو صواب اليوم قد يلغى غداً والعكس صحيح (مليك، برجم، 2010م، ص21-22)، وهنا يرى الباحث أن الابتكار الذي يصلح لمكان ما قد لا يصلح لمكان آخر، وكذلك فإن الابتكار الاقتصادي الصالح لزمان ما قد لا يكون بالضرورة صالحاً لزمان آخر، ومن ثم لا بد أن تتسم الأفكار الابتكارية في المجال المالي بالجدية والحدأة.

ثانياً: عناصر الابتكار الاقتصادي:

هناك منهج يعتبر كمدخل مهم في دراسة الابتكار الاقتصادي، ويتمثل في دراسة عنصره الأساسيين، وهما: القدرة على التفكير الإستراتيجي، والقدرة على بناء ثقافة في المنظمة (سلطان، 2002م، ص46)، ويمكن شرحهما على النحو التالي:

1- التفكير الإستراتيجي:

يرتبط أساساً بقدرة المنظمة على وضع الخطط المستقبلية للتطوير والتغيير والتأقلم، وترتكز في ذلك على برامج التنبؤ التي تعتمد على تقنيات متطورة، وكذا الإحصاء (Paul J. Fortier, Howard Edgar Michel, 2003, p.89).

إن التفكير الإستراتيجي ينبع من الرؤية الواضحة والمشاركة، وكذا وعي الأفراد برسالة المنظمة ودورها وأهدافها الرئيسية، بالإضافة إلى ذلك فهو يهتم بإيجاد قيم وأهداف مشتركة بين العاملين، وهو أمر ليس بالسهل، وقليل ما يوجد مثله في الدول النامية ومنظمتها، حيث يلاحظ أن جهود العاملين مبعثرة نتيجة لانعدام المناخ التنظيمي الصحي، كما توجد فكرة لدى بعض المنظمات العربية، تعتبر أن استمرار المدير في منصبه موهون بوجود النزاع والتنافس غير النزيه، وكل هذا بسبب نقص الوعي التنظيمي وعدم وجود التوافق والانسجام والتعاون بين أعضائها (عبوي، 2006م، ص53).

ويرى البعض أن هذا أحد أسباب عجز المنظمات في الدول النامية عموماً والعربية خصوصاً، ويرى أن مشكلة التخلف الإداري لا تكمن فقط في تقادم التشريعات والهياكل التنظيمية، بل تكمن في تشتت الجهود وغياب الانتماء للمؤسسة، وكل هذا سببه ضعف التفكير الإستراتيجي الذي يجعل العاملين يعطون اهتماماً بتحقيق أهداف المنظمة وإستراتيجياتها (A. Van Vaerenbergh, 2005, p.70).

ويُعدُّ الانتماء من العوامل المساندة للنقطتين السابقتين؛ الكفاءة والجماعة. والثقة هنا تعتمد على مدى استعداد العاملين في المؤسسة للوقوف خلف أهداف المؤسسة وغاياتها. والانتماء لأهداف المؤسسة وغاياتها لن يتحقق دون رؤية مشتركة لأهمية هذه الأهداف من وجهة نظر العاملين، والمشكلة أن كثيراً من المؤسسات تعاني وتندمر فيها الإدارات من عدم ولاء المرؤوسين وانتمائهم. والمشكلة التي تقع فيها الإدارات أنها تتجاهل عدم فهم واستيعاب وقناعة العاملين بأهداف أو غايات المؤسسة ببساطه، لأن هذه الأهداف والغايات من وجهة نظر العاملين هي فقط تخدم المديرين أو المساهمين على حساب العاملين، فلا تتحقق الرؤية المشتركة التي تعدُّ مطلباً أساسياً لانتماء العاملين ووقوفهم خلف غايات المؤسسة مدافعين عنها (سليمان، و هب، 2011م، ص101).

إن الانتماء المشترك لغايات وأهداف المؤسسة ورسلتها ينسجم ويتماشى مع وجود أفراد بموصفات الريادة ومؤسسات بأشكال منبسطة أفقية في هيكلها التنظيمي ومديرين يشرّفون على عدد أكبر من ذي قبل، بسبب توافر الموظف والعامل صاحب المعرفة والخبرة، وتوفير برامج التمكين التي تؤدي إلى تحقيق نتائج عالية في مستويات الأداء المالي (Anat Arkin, 1992, p.80).

ومن هذا المطلق كان الاهتمام بالجوانب السلوكية أمراً لا بد منه من أجل خلق وتكوين ثقافة تنظيمية مشتركة لتحقيق الاستقرار والنمو، وبالتالي تحضير قاعدة صلبة للتفكير الإستراتيجي المحترف في المجال المالي (أبو شقمة، ياسين، 2010م، ص80).

2- بناء ثقافة المنظمة:

ثقافة المنظمة هي مجموعة من القيم والمعتقدات والأحاسيس الموجودة داخل المنظمة، والتي تسود بين العاملين مثل طريقة تعامل الأفراد مع بعضهم، وتوقعات كل فرد من الآخر ومن المنظمة (Lynda Gratton, 1999, p.63)، وكيفية تفسيرهم لتصرفات الآخرين، ويتطلب التمكين الإداري في أية منظمة أن تكون القيم الثقافية السائدة ملائمة وتشجع وتحت على العمل بروح الفريق وتبادل الأفكار ومساعدة الآخرين، والقدرة والمثل الأعلى للقيادة الفعالة التي تعني بالتمكين والعوامل التي تساعد وتحفز على تبني مفهوم التمكين (الطجم، السواط، 2010م، ص11).

وتُعدُّ الثقافة التنظيمية الداعمة للتمكين أحد ركائز ومقومات التمكين، حيث أن الثقافة التنظيمية السائدة تؤثر في كافة أنشطة المنظمة، وتحت على العاملين التكيف مع هذه الثقافة، فكلما كانت الثقافة التنظيمية مرنة ومشجعة على جعل العاملين يتخذون القرارات المتعلقة بأعمالهم (B. Dalle, 2006, p.94)، كلما كان العاملون أقرب إلى التمكين يعكس الثقافة التنظيمية الجامدة التي لا تشجع على الابتكار الاقتصادي والمبادأة وتحمل العليين للمسؤولية، مما يؤدي إلى الجمود والتطبيق الحرفي للأنظمة والأداء المالي، وبالتالي وأد الإبداع في مهده، وعدم تمكين المنظمة من خلق قيادات إدارية لديها القدرة على الابتكار الاقتصادي (الطراونة، 2012م، ص66).

ثقافة المنظمة تهتم أساساً بإيجاد قيم مشتركة بين العاملين، من خلال التركيز على احتياجاتهم، واعتبارهم شركاء حقيقيين يجب الاهتمام بهم واحترامهم وتدريبهم، وإتاحة المجال لهم لصناعة مستقبل المنظمة، والعمل على ترسيخ معايير أداء متميزة، مبنية على الابتكار الاقتصادي والتنظيمي (J. H. H. Weiler and I. Motoc, 2003, p.187).

إن هذا النوع من الثقافة هو ما يميز الإدارة اليابانية التي استطاعت أن تصبح قوة اقتصادية عالمية، حيث أنها تعتبر المنظمة كأسرة واحدة متكاملة، ويمكن للمسؤول مثلاً أن يكلف العاملين بالعمل الإضافي من دون الحصول على أجر، وهذا بسبب روح الإنتماء، ولهذا تعتبر أقل الدول من ناحية الإضرابات العمالية (G. Handl, 2005, p.129).

إن التنظيم في المؤسسة يمكن أن يشمل إتباع نظام الإدارة بالأهداف، أو اساليب التطوير التنظيمية، والعمل على إدارة المشاريع بطريقة مرنة، بالإضافة إلى توفر دائرة لمراقبة النوعية والجودة (القيوتي، 2000م، ص99).

وتنقسم الثقافة التنظيمية إلى نوعين، هما (عكاشة، 2008م، ص73):

- **النوع الأول: الثقافة التنظيمية المرنة:** فالقادة المالبين الذين ينتهجون الثقافات المرنة يكتسبون القدرة على طرح تغييرات على نظم تشغيل المنظمة، بما في ذلك التغييرات في إستراتيجيات المنظمة وهيكلها، مما يمكن المنظمة من التكيف مع المتغيرات التي تحدث في البيئة الخارجية، ومن ثم تتيح الثقافة المرنة للفرصة للمنظمات التي تنتهجها أن تبقى وتستمر في البيئات المتغيرة اعتماداً على أدائها المالي الذي يتطور باستمرار نتيجة الدور الفاعل لهذه الثقافة في تمكين العاملين (Mohammed S. Obaidat, 2010, p.286)، ويرى الباحث أن الثقافة التنظيمية المرنة، سوف تساهم في خلق الأجواء المناسبة لتوليد الأفكار الابتكارية، وبالتالي فإن المنظمة التي تتمتع بالثقافة التنظيمية المرنة، تمنح العاملين فيها وخاصة القادة والمديرين إمكانية التوصل إلى أفكار متميزة، يمكن التعويل عليها لتحويلها إلى أفكار ابتكارية، تدر المزيد من الإيرادات للمنظمة.

- **النوع الثاني: الثقافة التنظيمية الجامدة:** حيث تعاني المنظمات التي تنتهج الأنماط الثقافية الجامدة العديد من المشكلات التي من أهمها عجز قيادة المنظمة عن تمكين العاملين أو تطوير الأداء المالي؛ نظراً لإمكانية تغير البيئة، ووجود منافسين جُدد أو تقنية جديدة تتطلب مثل هذا التغيير (فضالة، 1996م، ص46). كما أنه لا يترتب عليها تطوير الهياكل التنظيمية حسب احتياجات الإدارات والأقسام المختلفة، حيث يعتاد القادة بعد الانتهاء من تشكيل هياكلهم التنظيمية على استخدام الطرق التقليدية في إدارة العمل المالي، ونادراً ما يتصرفون على تأثير الهياكل العامة على القواعد السلوكية والقيم الثقافية، حيث إن الهيكل التنظيمي للمنظمة قد يعزز القصور الذاتي (B. Dalle, 2006, p.87)، ويرى الباحث أن الثقافة التنظيمية الجامدة تُعدُّ من أهم معوقات الابتكار الاقتصادي، حيث تكون بمثابة الصخرة التي تقف في طريق الأفكار الابتكارية، ومن ثم تقويض قدرات القادة والمديرين، وتقليل فرص الابتكار الاقتصادي إلى أبعد حد ممكن.

ويرى البعض أنه يجب إرساء ثقافة تنظيمية تقوم على احترام الإنسان الفرد وتثقيف العاملين وتشعرهم بأهمية دورهم في المشاركة والمبادرة، وثقافة التمكين هذه تدعو إلى إحلال الثقة محل الشك، وإحلال الالتزام محل الرقابة، وإحلال الفريق محل الفرد، وإحلال القائد محل المدير والتعامل مع التدريب كاستثمار وليس تكلفة (شليبي، 2000م، ص138).

ويشير البعض الآخر إلى أنه لا بد من إدراك حقيقة أن أفضل الثقافات التنظيمية هي تلك الثقافة التي تتوافق مع التغيرات الهيكلية والتنظيمية من أجل تحقيق التمكين في المنظمة، وأن مسؤولية المديرين الماليين هو تكييف الثقافة عندما لا تتوافق مع إستراتيجية المنظمة الجديدة، ويشير "شير هورن" (Schermehrom, 2001) أن على المديرين امتلاك ثقافة تجعلهم يقرروا ما العمل الذي يجب أن يعملوه بأنفسهم، وما العمل الذي يجب أن يتركوه للآخرين (إبراهيم وآخرون، 2004م، ص85).

3- توفر مبادئ الابتكار الاقتصادي:

لقد وضع الكثير من مدراء الشركات والمنظمات العالمية مجموعة من الآراء الرائدة في مجال الابتكار الاقتصادي، وحتى تكون مؤسستنا نامية، وأساليبنا مبتكرة وخالقة، ينبغي مراعاة بعض المبادئ الأساسية فيها (M. Savino, 2005, p.99)، سواء كنا مدراء أو أصحاب قرار، وهذه المبادئ تتمثل فيما يلي:

1. إفساح المجال لأي فكرة أن تولد وتنمو وتكبر، ما دامت في الاتجاه الصحيح، وما دما لم تقطع بعد بخطئها أو فشلها، فكثير من المحتملات تبدلت إلى حقائق، وتحولت احتمالات النجاح فيها إلى موقفية (الشماع، عبد الله، 2006م، ص57).
2. إن الأفراد مصدر قوتنا، والاعتناء بتنميتهم ورعايتهم يجعلنا الأكبر والأفضل والأكثر ابتكاراً وروحاً، ولتكن المكافأة على أساس الجدارة واللياقة (Gordon, Judith R. & Gordon, Steven R., 1999, p.77).
3. احترام الأفراد وتشجيعهم وتنميتهم بآتاحة الفرص لهم للمشاركة في القرار وتحقيق النجاحات للمؤسسة، فإن ذلك كفيل بأن يبذلوا قصارى جهدهم لفعل الأشياء على الوجه الأكمل (Christopher, M., 1992, p.331).
4. التخلي عن الروتين والاعتماد على اللامركزية في التعامل، لأنها تنمي القدرة الابتكارية، وهي تساوي ثبات القدم في سبيل التقدم والنجاح (الحدر، الشنطي، 2017م، ص63).
5. التجديد المستمر للنفس والفكر والطموحات، وهذا لا يتحقق إلا إذا شعر الفرد بأنه متكامل في عمله، وإن العمل ليس وظيفة فقط، بل يبني نفسه وشخصيته أيضاً، فإن هذا الشعور الحقيقي يدفعه لتفجير الطاقة الابتكارية الكامنة بداخله، وتوظيفها في خدمة تحقيق المنظمة (عناية، 2006م، ص44).
6. محاولة القيام بكل ممتع لا وظيفة فحسب، ويكون كذلك إذا حولنا النشاط إلى مسؤولية، والمسؤولية إلى طموح (Paul J. Fortier, Howard Edgar Michel, 2003, p.205).
7. التطلع إلى الأعلى دائماً من شأنه أن يحرك حوافز الأفراد إلى العمل وبذل المزيد للسعي إلى تحقيق الأهداف الأبعد باستمرار، وكما تحقق هدف ننظر إلى الهدف الأبعد، حتى نضمن مسيرة فاعلة وحيوية ومستمرة ومتكاملة (صديقي، الرزاز، ب. ت، ص20).
8. ليس الابتكار أن تكون نسخة ثانية أو مكررة في البلد، بل الابتكار أن تكون النسخة الرائدة والفريدة، لذلك ينبغي ملاحظة تجارب الآخرين وتقويمها أيضاً، وأخذ الجيد وترك الرديء لتكون أعمالنا مجموعة من الإيجابيات (Al-Jalal Ibrahim & Kurdi, Manal Mohamed, 2000, p.70).
9. يجب إعطاء التعلم عن طريق العمل أهمية بالغة؛ لأنه الطريق الأفضل لتطوير الكفاءات وتوسيع النشاطات ودمج الأفراد بالمهام والوظائف (خير الله، 2008م، ص137-139).

ويمكن توضيح عناصر الابتكار الاقتصادي من خلال الشكل رقم (2) التالي:

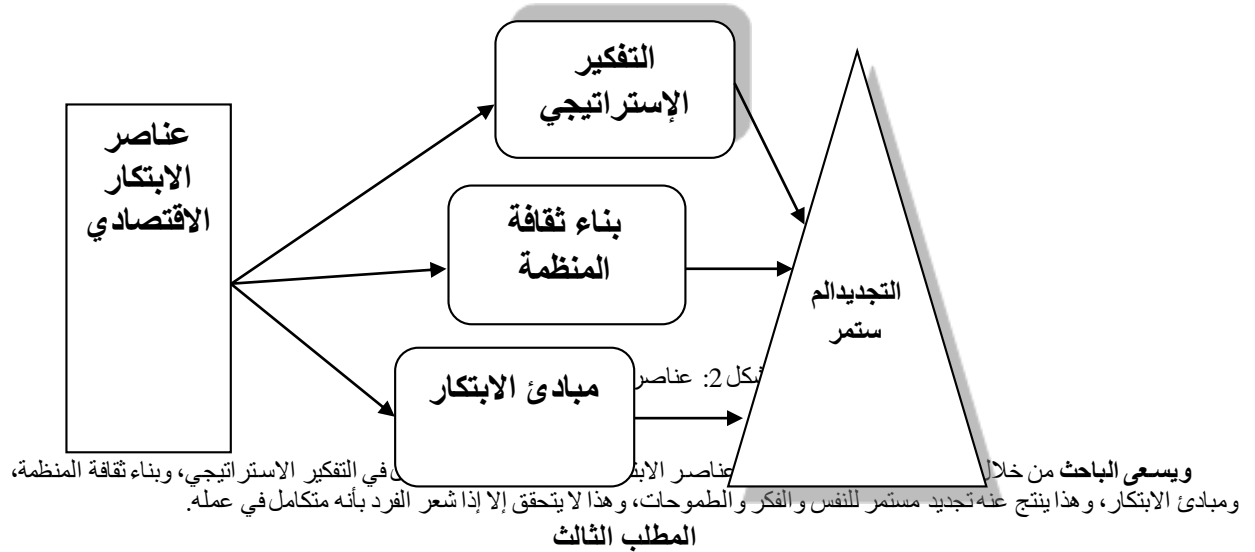

طرق اللجوء إلى الابتكار الاقتصادي

تعتبر الممارسة الداخلية لنشاطات البحث والتطوير، على مستوى المؤسسة، الوسيلة الوحيدة لإحداث الابتكار الاقتصادي، بالإضافة إلى هذه المصادر الداخلية، هناك مصادر خارجية عديدة وقابلة للاستغلال بتكاليف ومخاطر متفاوتة، تزودنا بابتكارات مالية وأفكار جديدة ونيرة، كمرآة للبحث العامة، والخاصة والجامعات، والنوادي العلمية والثقافية، إضافة إلى المؤسسات الاقتصادية الأخرى (النعمي، التميمي، 2006م، ص175).

وعلاً بمبدأ ترشيد الموارد المتاحة للمؤسسة يتطلب المفاضلة في اختيار أحسن البدائل قصد إحداث الابتكارات المالية، ويتم ذلك إما بالممارسة الفعلية والكاملة أو الجزئية لنشاطات البحث والتطوير، وإما باقتناء وشراء الأفكار والأبحاث والابتكارات المالية (Christopher, M., 1992, p.110)، ويمكن حصر مختلف طرائق اللجوء لإنتاج الابتكار الاقتصادي فيما يلي:

أولاً: إدماج نشاطات البحث والتطوير:

يعطي إدماج نشاطات البحث والتطوير المؤسسة استقلالية كبيرة لوضع وتسيير سياسة ابتكارية مالية تحقق من خلالها مكاسب معتبرة في حالة النجاح، كما يضمن لها جانباً هاماً من السرية والثقة لنشاطاتها (علوطي، 2008م، ص37)، ويحد من التطلعات المتاحة للمقلد في الحصول على الأفكار الجديدة والابتكارات المالية قيد الإنجاز، فحسب أدبيات اقتصاد وتسيير البحث والتطوير "للمؤسسة الفضل على الأقل في نصف الابتكارات المالية المستعملة من قبلها (النشاطات الداخلية للبحث والتطوير)، وهذا مما يجعل المنافسين يستغرقون فترة ما بين سنتين إلى ثلاثة سنوات لتقليد فكرة الابتكار الاقتصادي (Gordon, Judith R. & Gordon, Steven R., 1999, p.41).

وكما يقود الإدماج الفعلي والكامل لنشاطات البحث والتطوير لنتائج جيدة ومعتبرة وموضع حماية عادلة وفعالة عن طريق شكل من أشكال الحماية القانونية للأفكار والابتكارات المالية والاختراعات (براءات الاختراعات والعلامات والنماذج) (الجعوني، 1974م، ص91)، وبالمقابل تعتبر الممارسة الفعلية والكلية لهذه النشاطات على مستوى المؤسسة الوسيلة الأطول من ناحية الزمن والأكثر تكلفة في توفير وتخصيص الموارد، والأعلى مجازفة وخطر، فعلى سبيل المثال (ابتكار دواء جديد يتطلب جهوداً مضمّنية في نشاطات البحث والتطوير، وفترة زمنية تمتد إلى غاية 10 سنوات ومبلغ معتبر من المال) (J. H. H. Weiler and I. Motoc, 2003, p.106).

هذا بالإضافة إلى عدة اعتبارات تأخذها المؤسسة بعين الاعتبار عند قيامها بالممارسة الداخلية لنشاطات البحث والتطوير (حميد، 2005م، ص88)، التي تتمثل في:

1. الإلمام بالمعلومات والأفكار والمعارف العلمية المتاحة داخلياً، على مستوى مختلف وظائفها، وخارجياً، والأفكار المتداولة على مستوى المنظمات الأخرى والسوق، أي الرصد والإصغاء للوسط الداخلي والخارجي (Joan Pynes, 2004, p.82).
2. وفي تجنيد الطاقات والإمكانات المتاحة لديها، التي تشكل كلها أسس نجاح مشاريع البحث والتطوير أو البحث التطبيقي، مع الأخذ بعين الاعتبار الأهداف الإستراتيجية للمؤسسة، والتقيّد بالخطط والسياسات والموازنات المحددة من قبلها، مع نوع الاستقلالية والتسيير الديناميكي (الفعال) لمستخدميها لاكتشاف الأفكار الجديدة والنيرة وتطويرها وتكييفها مع متطلبات السوق (ناصر، 1988م، ص11).
3. كما يتوقف نجاح المشاريع الداخلية للبحث والتطوير على توافر الشروط الأساسية الآتية:
 - أ. اقتراحات وابتكارات مالية صادرة من مبتكر قادر على استغلال الأفكار الجديدة والنيرة والمعارف العلمية، وجعلها متكيفة مع المؤسسة (K. Murphy, 2005, p.187).
 - ب. وسط مشجع ومدعم للتجديد والابتكار الاقتصادي.
 - ج. التعاون والتنسيق الداخلي، خاصة بين وظائف البحث والتطوير والإنتاج والتسويق (ماجد، 2016م، ص5).

ومن خصائص المبتكر المالي الذي يحتل هرم هياكل البحث والتطوير، الإلمام بشؤون التسيير في التخطيط والتنظيم والتنسيق والتوجيه والمراقبة، مع العمل على ضمان وتحقيق أهداف المؤسسة والمتابعة والمراقبة الدقيقة لنشاطات البحث والتطوير، وكذا الإدراك التام بأن الإتيان بالأفكار الجديدة والمعارف يخضع لمعطيات تخص الفرد والمحيط الدائر به، إلى جانب الإشراف اللين والعناية مع الحزم فيما يخص جو العمل (بن ندير، منصور، 2006م، ص19).

ثانياً: عقود واتفاقيات التعاون:

يفع النقص في القدرات والإمكانات المتاحة لدى المؤسسة، والاحتياج للمعارف العلمية والتكنولوجية والارتفاع في تكاليف نشاطات والتطوير المؤسسة للقيام بعقود مصادق عليها أو إبرام اتفاقيات تعاون بينها وبين مؤسسات أخرى أو مثلية لها في نفس القطاع، أو في قطاعات اقتصادية أخرى، تهدف إلى إنشاء جملة من العلاقات والارتباطات في مجال البحث التطبيقي، وفعاليتها محددة بجدية الأطراف المعنية وديناميكية المديرين الماليين (Borins, S., 1995, p.144).

إن أساس قيام وإنشاء العلاقات والارتباطات في مجال البحث والتطوير، يمثل في استغلال المعلومات والمعارف المكتسبة لكل طرف، وتوحيد الجهود الرامية لإحداث الابتكارات المالية، واختصار في مدة إنجاز مشاريع البحث والتطوير وتحمل مشترك للتكاليف والأخطار (عبد الوهاب، 2011م-2012م، ص36)، ومن وجهة نظر أن الطاقات والإمكانات والمعارف لا تتواجد دائماً وكلياً في مجال ومكان معينين، فهذه الارتباطات والعلاقات تشكل محكاً حقيقياً للاستفادة بين المؤسسات، وتوحيداً للطاقات والإمكانات والقدرات خاصة في مجال البحث والتطوير، ومثال ذلك: ما حدث من التحالف بين مؤسستي IBM و Apple في يولييه عام 1991، الهدف إلى تكوين نظام استغلال قادر على منافسة منتجات مؤسسة Microsoft (Windows, Ms-Dos) (A. Van Vaerenbergh, 2005, p.112).

ويشكل هذا التعاون فضاءً ومجالاً واسعاً لكل المؤسسات مهما كان حجمها، وخاصة المؤسسات الصغيرة والمتوسطة التي تكتسب قدرات وإمكانات محدودة، فالتعاون فيما يتعلق بينها يعتبر وسيلة للتكفل بنشاطات البحث والتطوير. وفكرة الارتباطين تنطلق من المنظور النظامي، فالعلاقات بين أجزاء أو مكونات النظام أمر ضروري، والارتباطين فيما بينها تثبت وتدعم وجود النظام (حميد، 2005م، ص28)، ويمكن تحديد أهم أنواع الارتباطات فيما يلي:

1. الارتباطات المباشرة والرسمية.
2. الارتباطات عن طريق التبادلات المادية.
3. الارتباطات بواسطة تبادلات غير مادية (الحرب، الشنطي، 2017م، ص129).

فهما كانت الارتباطات بين المؤسسات، فالأهم هو استغلال العلاقات الناشئة بكيفية تسمح بالتكفل الفعلي والفعال لنشاطات البحث والتطوير أو البحث التطبيقي، وذلك باستغلال المعارف والأفكار المكتسبة والمتاحة، وتحمل مشترك للتكاليف والأخطار وتقليص في مدة إنجاز مشاريع البحث التطبيقي، أي العمل على دعم عمليات الإبداع التكنولوجي والإسهام في تحقيق ميزات في الإنتاج والمنتجات تعزز مكانة المؤسسة في السوق (Joel le baris, 1993, p.148•Broustail et frederic frey).

ثالثاً: المقالة الباطنية:

يعني الحصول على الإبداعات التكنولوجية عبر المقالة الباطنية، قيام المؤسسة بعملية اللجوء إلى مؤسسات أخرى، طالبة منها تنفيذ جزئي أو كلي لنشاطات البحث والتطوير، أي إبرام اتفاقيات مع منظمات خارجية. ونجد ضمن هذه المنظمات مثلاً: مكاتب الدراسات، ومراكز البحث العلمية والخاصة، والجامعات والمؤسسات الصناعية المتخصصة والجمعيات والنوادي العلمية وغيرها (حصون، 1996م، ص32)، ويتم اللجوء لهذا الشكل قصد الحصول على الابتكارات التكنولوجية بسبب نقص الإمكانيات المالية والقدرات البشرية المؤهلة لدى المؤسسة المعنية، وهذا الشكل "يوجد بكثرة في أهم البلدان الصناعية، خاصة الولايات المتحدة الأمريكية، حيث عدد كثير من المؤسسات يتعامل مع الباحثين الجامعيين" (Michael Armstrong, 2003, p.116).

فالمقالة الباطنية في مجال البحث والتطوير وسيلة مهمة للمؤسسة لإنشاء علاقات مع الخبراء والمختصين ذوي مستوى عالي (طاقات وموارد بشرية مؤهلة) في مجال الابتكار الاقتصادي، فنشاط الجامعات يتمثل في التدريس والبحث العلمي بنوعيه (سلام، الساقبي، موسى، النعيمي، 2017م، ص19). البحث العلمي الأساسي ويتناول التوسع في مجال المعرفة العلمية، والبحث العلمي التطبيقي الذي يحول المعارف العلمية إلى حلول فنية. أما مراكز البحث العامة والخاصة تقوم بتحويل المعلومات العلمية إلى تكنولوجيا، وإلى حلول تقنية للمشاكل والصعوبات الفنية المجابهة للمؤسسات الاقتصادية وإنتاج الابتكارات المالية بصفة عامة، فإبرام اتفاقيات للإنجاز الجزئي أو الكلي لنشاطات البحث والتطوير مع المنظمات المتخصصة في إنجاز الابتكارات المالية والمعارف العلمية البحتة، تعتبر من الإجراءات التسييرية الفعالة، وتمكن المؤسسات من تخفيض التكاليف وترشيد الموارد المتاحة لديها (الحجازي، الزبيدي، 2017م، ص80).

رابعاً: اقتناء الرخصة:

إن اقتناء رخصة الابتكار التكنولوجي، تعتبر الوسيلة المباشرة للحصول على الابتكار الاقتصادي، وهي عبارة عن شراء ابتكار معين من طرف خارجي، كما تعتبر الأكثر فاعلية لكون المؤسسة على علم بما تشتري، والأسرع من ناحية الاستغلال والنقل المباشر للمعارف والمعلومات عن موضوع الابتكار الاقتصادي في حالة التعاقد، والأقل تكلفة بناءً على العدد الكبير من طالبي الاقتناء (Michael Armstrong, 2003, p.53).

فبانتشار خبر حول ابتكار مالي معين، تتقدم المؤسسات الصناعية المعنية لمصدر الابتكار الاقتصادي الأصلي – صاحب الابتكار الاقتصادي – بطلب لشراء أو الحصول على حق الاستعمال والاستغلال بواسطة رخصة يصادق عليها الطرفان بصفة إرادية، ومباشرة يتم الكشف ونقل المعلومات والمعارف عن المنتج أو الطريقة الفنية للإنتاج (فوزي، 1996م، ص63)، ويضم العقد بنوداً وشروطاً معينة منها خاصة:

1. موضوع العقد.
2. مدة العقد.
3. مجال الاستغلال.
4. المكافأة المالية (مبلغ معين أو نسبة مئوية).
5. شروط الإشعار بالتحسينات التي قد يقوم بها الحاصل على الرخصة، وكذا كيفية حل النزاعات في حالة وقوعها (الحجازي، 2001م، ص29).
6. شروط أخرى تخص مثلاً العلامات التجارية للطرفين (دراز، 1984م، ص18).

ويمكن توضيح طرق اللجوء إلى الابتكار الاقتصادي من خلال الشكل رقم (3)، وذلك على النحو التالي:

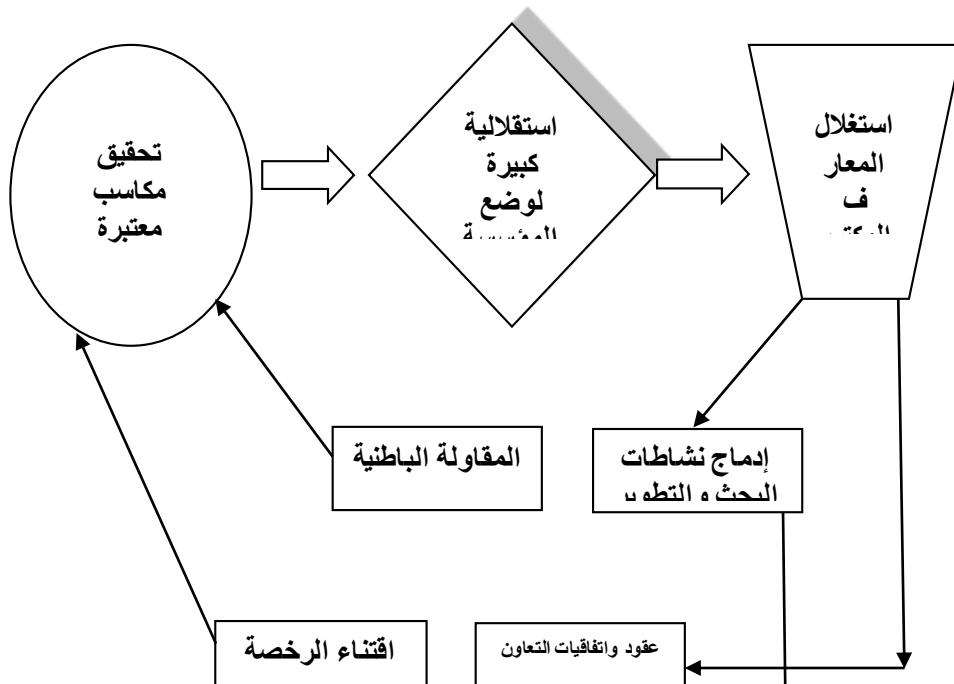

شكل 3: طرق اللجوء إلى الابتكار الاقتصادي(1)

ويسعى الباحث من خلال هذا الشكل إلى توضيح أن طرق اللجوء إلى الابتكار الاقتصادي تتمثل في إدماج نشاطات البحث والتطوير، وغود و اتفاقيات التعاون، والمقاوله الباطنية، واقتناء الرخصة، وهذا بدوره يؤدي إلى تحقيق مكاسب معتبرة للمؤسسة، ويساهم في استغلال المعرف المكتسبة من قبل الجهات التي يتم التعاون معها.

المبحث الأول

مفهوم الابتكار في الإسلام

تمهيد وتقسيم:

اتضح لنا من خلال المبحث السابق أن الابتكار عُرف بتعريفات كثيرة، لعل من أفضلها القول بأنه "الطرق أو الأساليب الجديدة المختلفة الخرجة أو البعيدة عن التقليد التي تستخدم في عمل أو تطوير الأشياء والأفكار. وهو عملية عقلية تعبر عن التغييرات الكمية والجذرية أو الجوهرية في التفكير، وفي الإنتاج أو المنتجات، وفي العمليات أو طرق وأساليب الأداء، وفي التنظيمات والهياكل" (محمد، 2016: 6).

وسيقصر حديثنا في هذا المبحث عن الابتكار في الفكر الإسلامي، ويُقصد به: الابتكار في المؤسسات الإدارية، من حيث قدرة المؤسسات المالية والاقتصادية على تحقيق رغبات زبائنها والمستثمرين فيها بشكل سريع وفعال مع الأخذ بالاعتبار التغييرات التي تطرأ على السوق ومواكبتها بشكل دائم، وذلك وفق النظم والأطر الإسلامية الشرعية التي تميز وسائل الابتكار و غاياته وأدواته وطرق تطبيقه، بخلاف الأنظمة الوضعية الأخرى (محمود، 2017).

والابتكار المقصود ليس مجرد الاختلاف عن السائد، بل لابد أن يكون هذا الاختلاف متميزا إلى درجة تحقيقه لمستوى أفضل من الكفاءة والمثالية، ولذا فلا بد أن تكون الأدوات والمنتجات الاقتصادية المبتكرة تحقق ما لا تستطيع الأدوات والمنتجات السائدة أن تحققه (سويلم، 2004: 5).

ويمكن أن نحدد مجالات الابتكار في الإسلام في ما يلي:

1. **المنتج:** هو الابتكار الذي يأتي بالمنتجات الجديدة التي تقدم من أجل الإيفاء بالحاجات الحالية للعملاء بكفاءة أعلى وخصائص أفضل.
2. **العملية:** هو الابتكار الذي يأتي بطريقة جديدة أو تكنولوجيا جديدة تغير طريقة العمل أو الإنتاج بما يحقق إنتاجية أعلى، أو استخدام مواد أقل، أو تحسن خصائص المنتجات المادية أو الوظيفية أو الجمالية.
3. **الخدمة:** كما يكون الابتكار في المنتجات الجديدة يكون كذلك في الخدمات الجديدة. فتقديم خدمة جديدة عادة ما تمثل ابتكاراً جديداً.
4. **نموذج الأعمال:** لكل اقتصاد نماذج المتميزة، فنموذج الأعمال هو التصميم الإستراتيجي لكيفية سعي الشركة أو المؤسسة لتحقيق الربح من إستراتيجيتها وعملياتها ونشاطاتها (محمد، 2016: 10-12).

وللتعرف على مفهوم الابتكار في الإسلام، سيتم تقسيم هذا المبحث إلى ثلاثة مطالب، وذلك على النحو التالي:

- **المطلب الأول:** الحاجة للابتكارات الاقتصادية.
- **المطلب الثاني:** نماذج من شواهد الابتكارات الإسلامية.
- **المطلب الثالث:** الآفاق المستقبلية وفق معطيات الواقع والمتوقع للاقتصاد الإسلامي المبتكر في نمط الحياة الإسلامي، وتأثيره على حياة الناس.

المطلب الأول

الحاجة للابتكارات الاقتصادية

هذا المبحث يعالج فكرة ارتباط الابتكار بالاقتصاد الإسلامي، فهل بالفعل وجدت ابتكارات اقتصادية إسلامية في مختلف مراحل تطور الدولة الإسلامية وأنظمتها؟ وإذا كان هناك ما يشهد بهذا حقا فما الدافع الذي كان وراء فكرة الابتكار والتطوير الاقتصادي المستمر خلال العصور الإسلامية السابقة؟

أولاً: أهمية الابتكارات الاقتصادية بشكل عام وفي الاقتصاد الإسلامي بشكل خاص:

إن من البدهي القول بأن المعاملات المالية والاقتصادية للناس تتغير بتغير الأزمان وتطور ظروف الحياة، وتبعاً للتغيرات الديموغرافية (الهوراني، 2020) للسكان في الأقاليم، وتطور الحياة على كافة الأصعدة العلمية والصناعية وغيرها، وتبعاً لتطور وتغير طرق المواصلات ووسائل الاتصالات، فمن الطبيعي أن كل هذه العوامل تلعب دوراً هاماً في تجدد الحاجات الاقتصادية للناس، خاصة في أنماط حياتهم اليومية من مسكن ومليس وغذاء وصحة وغير ذلك، ولا شك أنه عندما اتسعت رقعة الدولة الإسلامية بسبب الفتوحات، وبدأت الثقافات المختلفة بالاندماج مع المجتمع المسلم،

(1) الشكل من اجتهاد الباحث.

برزت الحاجة إلى إجراءات تنظيمية منسجمة مع حجم التطورات المتحققة ومع تعاليم الدين الإسلامي الحنيف. وقد صاحب ذلك تطور واتساع في الأفكار الاقتصادية لدى علماء المسلمين، انعكست في كثير مما وصل إلينا من التراث العلمي الذي دون وشهد بهذا التطور (الحواراني، 2000).

ثانياً: أهم أسباب الحاجة للابتكارات الاقتصادية الإسلامية:

إن الفقه الإسلامي غني بالصور الفقهية التي تمثل سياسات بديلة لكيفية ممارسة المعاملة، وفي ظل ظروف وافتراضات متعددة، بعضها جاء بعد استقرار الواقع، والآخر جاء استشرافاً للمستقبل، وهذا ما يفيد الفكر الاقتصادي في متابعته لدراسة المستجدات، ويستطيع من خلاله أن يقوم بعملية الابتكار للمنتجات أو النظم، أو الحلول الاقتصادية (عمر، 2020).

والمشكلة الاقتصادية الأساسية التي يعمل الفكر الاقتصادي على حلها هي كيفية التوفيق بين الموارد المحدودة والحاجات المتعددة، والرسالة خلصت إلى أن الآلية التي تحقق ذلك هي أسعار السوق، فالأفراد أحرار في تحديد ما ينتجون كما ونوعاً لتحقيق أقصى ربح ممكن في ضوء ما تسمح به أسعار السوق، وأحرار فيما يستهلكون كما ونوعاً في حدود ما تسمح به قدراتهم على حساب أسعار السوق. والشيو عية بدلت آلية السوق بتدخل الدولة لتحديد ماذا ينتج؟ وبأى كمية وبأى سعر ولمن ينتج؟

كلا النظامين أدى إلى مشكلات كثيرة، الأمر الذي يتطلب إدخال آلية أخرى لضمان الاستفادة المثلى من الموارد المتاحة في المجتمع وبأن تؤدي هذه الآلية إلى ترشيح السلوك الاقتصادي للناس بالمحافظة على الموارد وتوجيهها للإشباع المفيد للمجتمع في عدالة وتوازن، وهذه الآلية لا يمكن أن تستمد من سلوك الناس الواقعي كما يعبر عنه جهاز الأسعار في السوق من حيث العرض والطلب،

بل لابد من آلية تبدأ من ترشيح رغبات الناس غير المحدودة وقصرها على ما يفيد الإنسان والكون وفي حدود الاعتدال والقوامة، ثم آلية لا تسمح باستخدام الموارد في المظاهر والترف أو تبديدها، وآلية أخرى لحسن توزيع الموارد على أبناء المجتمع وهنا لابد من قيم ومثل أخلاقية تضبط سلوك الناس تجاه الموارد وكما يقول بعض المؤرخين بعد دراستهم الواسعة والمتعمقة لمختلف الحضارات أنه «لا يوجد مثال يعتد به في التاريخ السابق لعصرنا لمجتمع نجح في المحافظة على الحياة الأخلاقية بدون مساعدة الدين». وهكذا يظهر أنه لابد للاقتصاد المبتكر الذي نطمح له أن ينضبط بضوابط تحجزه عن التيه والانحراف، الأمر الذي يؤكد ضرورة الابتكار الاقتصادي ضمن الفكر الإسلامي (عمر، 2020: 275).

إن الإبداع والابتكار قد أصبحا حلاً جوهرياً من أجل البقاء في عالم متسارع متغير، ولأن بقاء المنظمة أو المؤسسة الاقتصادية هدف رئيسي، فالمنظمة التي لا تمتلك القدرة على الإبداع والابتكار في مجال عملها ستواجه – بالتأكيد – تحديات كبيرة وصعبة، وذلك لأن منافسيها يقومون بالابتكار والتحسين المستمر لمنتجاتهم وخدماتهم وعملياتهم (محمد، 2016: 12).

فالدور الفعال الذي يلعبه الابتكار باعتباره واحداً من محركات النمو الاقتصادي وتحسين الإنتاجية، وترسيخ خطوات التحول نحو اقتصاد المعرفة، إضافة إلى دوره في مواجهة التحديات التي تواجه الحكومات والشركات، هو الذي يجعله حلاً ضرورياً وليس خياراً في منظومة الاقتصاد الإسلامي (محمد، 2016: 3).

الابتكار سمة لهذا الدين الذي يحب التميز ولا يحب التقليد والمتابعة للأنظمة الأخرى على غير هدى، وينعكس في المجال الاقتصادي على عدم اتباع سياسة القطيع في السوق باتباع سلوك الشركات القائدة.

فمن عبد الله بن مسعود، أنه كان يقول: اغد عالماً أو متعلماً ولا تغدون إمعاً فيما بين ذلك. والإمعة هو الأحمق الذي لا يثبت على رأي. ويعزاً جزء كبير من الأزمات المالية إلى تقليد الآخرين عن غير علم ولا هدى. لذلك لابد لكل مستثمر في السوق من تفقه وتعلم أسوة بقول عمر – رضي الله عنه -: لا يبيع في سوقنا إلا من يفقهه وإلا أكل الربا شاء أم أبى، ويلاحظ أن الأمر موجه إلى البائع لأنه أساس السوق فإن انتظم عمله انضبط السوق بمن فعه. وهكذا فعلى الخبراء البحث دوماً عن سبل جديدة مبتكرة تميز الاقتصاد الإسلامي عن غيره من النظم الوضعية، ولا تلجئ المسلمين لتعاملات محرمة، أو مثار حولها الشبهات.

فيلاحظ مثلاً أن الهندسة المالية الإسلامية المنبثقة عن الربويين الملتحقين بركبتها تسعى إلى ابتكار أدوات مالية تعتمد على التوسع بالتورق المصرفي المحظور من أغلب فقهاء العصر. إضافة إلى التوسع في تطبيق صيغة المرابحة للأمر بالشراء وهي بالأصل رخصة وتركوا العمل بالعزيمة وهي بالمشاركة والمضاربة والسلم والاستصناع وغيرها من الصيغ الفاعلة في الاقتصاد.

والسبب في ذلك سهولة الهندسة المالية التقليدية من جهة، وحاجة الهندسة المالية الإسلامية إلى عمق في علوم الشريعة من جهة ثانية، وهذا مما لا يجذبونه، خاصة في المدى القصير نظراً لبحثهم عن أساليب مربحة بسرعة.

إن هذه الصيغ المتبعة تؤدي إلى التوسع في الدين ومصيرها ومآلها هو مصر الصيغ التقليدية من حيث الأثر السببي والمآل المخزي. فإذا كان العالم يرتقب الخلاص بالاقتصاد الإسلامي ومؤسساته ومنها المصارف الإسلامية فعلى المصرفيين والاقتصاديين المسلمين أن يوجدوا حلولاً مبتكرة منبثقة عن الفكر الاقتصادي الإسلامي الصحيح (قنطقي، وسامر، 2005: 100).

المطلب الثاني

نماذج من شواهد الابتكارات الإسلامية

أولاً: بعض نماذج الابتكارات الاقتصادية الإسلامية الأولى:

1- زكاة المال، والحكمة من بعض مصارفها:

وهي آلية مبتكرة لمحاربة الاكتناز (عماري، 2010: 80) وضمان سريان الدورة الاقتصادية في مسارها الطبيعي دون احتكار للسيولة المالية، فقد أوجب الإسلام على المال زكاة سنوية مقدارها 2.5% من المال النامي تنفع من ملاكه إلى الفقراء كمساهمة اجتماعية.

فالزكاة لا تدفع صاحب المال إلى استثماره فحسب، بل تدعوه إلى استثمار ذات ربحية عالية ومعقولة، لأنه سيخرج نسبة 2.5%، فلا بدّ من معدل ربح يزيد عن هذه النسبة حتى يضمن عدم تآكل المال ونقصانه، وحتى تتم التنمية الاقتصادية الشاملة في المجتمع يجب توفير التمويل الداخلي، ويقصد به تمويل وسائل إشباع الحاجات الأساسية المادية لفئة المحتاجين، وتوفير هذه الاحتياجات عادةً ما يكون مكلفاً للدولة، فتأتي الزكاة وتسد هذه الاحتياجات، مما يجعل الدولة تنفّغ لتمويل المشاريع الاقتصادية الكبرى. وبذلك نرى أن الزكاة تؤدي إلى زيادة الاستثمار الفردي، والكلّي للدولة، وأن هذا الاستثمار يؤدي بدوره إلى زيادة المال، ومن ثمّ زيادة الزكاة التي ستخرج من هذا المال، فيؤثر كل منها على الآخر بصورة إيجابية، تتعكس على المجتمع (عماري، 2010: 82).

فمن مصارف الزكاة الهامة جداً هي إغناء الفقراء والمساكين خاصة إذا كانوا قادرين على العمل، وفي هذا محاربة للبطالة وتشجيع للاستثمار. فهذا التوجيه للزكاة يدخل مستثمرون جدد إلى السوق مسددون للزكاة ومساهمون في العام التالي في حل مشكلة البطالة. وهذا الاتجاه - في إغناء الفقراء من مال الزكاة حتى يخرجوا من دائرة الفقر والحاجة - فهمه الصحابة غاية من غايات الزكاة السامية، وممن طبقه بجلاء عمر رضي الله، حيث كان يوجه عماله وولائه قائلاً: (إذا أعطيتهم فأغنوا) (ابن حزم، ب، ت، 155).

ومن مصارفها أيضاً سهم الغارمين أي المدينين، وهم مدينون غرقوا في ديون عجزوا عن سدادها قنطججي، وسامر، 2005: 131)، وهؤلاء أيضاً يدفع الزكاة لهم، ينتقلون من كونهم عالة على المجتمع، ليدعوا لغيرهم ويتفوق.

فالإقتصاد الإسلامي أوجد بسهم الغارمين حلاً مستداماً لتمويل خطر الائتمان العام، منعاً لأي أزمة ائتمانية تؤدي لسقوطه، أما الإقتصاد التقليدي فارتأى الحلّ كاستئثار عند وقوع الأزمات. لذلك ينتهج الإقتصاد الإسلامي حلاً دائماً طويل الأمد، بينما ينتهج الإقتصاد التقليدي حلاً عاجلاً استثنائياً وكأنه يتعلم بالممارسة (قنطججي، 2005).

إن الإقتصاد الإسلامي يسعى بحلولة البدء من الأسفل إلى الأعلى، أي من الضعيف للأقوى، مثل مساعدة المدين الأصلي مباشرة وهو الطرف الضعيف لسداد دينه تجاه دائته، أما الإقتصاد التقليدي فقد قدم مساعداته للقوي الذي ارتكب الخطأ أي انتهج حلاً يتجه من الأعلى إلى الأسفل، فأفاد القوي مرتين؛ الأولى عندما تركه يعبث إفساداً بالربا والثانية بضح الأموال له كي لا يقع مفلساً، بل وألحقه بقانون خاص للإفلاس لحمايته.

والميل للضعيف هي فلسفة يقوم عليها الإقتصاد الإسلامي في أغلب الحالات. لذلك فإن ضحك الأموال في السوق يجب أن يوجه للمدينين الأخيرين للوفاء بديونهم أسوة بفعل الخليفة العادل، لأن عمر بن عبد العزيز فكان لا يبيع خادم الرجل ولا مسكنه في الدين (قنطججي، 2005: 95).

2- نظام بيت مال المسلمين (المالودي، ب، ت):

وهو نموذج على ابتكار المؤسسات الاقتصادية والمالية الفعالة، وقد جمع بين اختصاصات وزارة المالية والبنك المركزي في عصرنا الحاضر، وباستقرار الأحكام المنظمة لعمل بيت المال يتضح أن مؤسسة بيت المال تتكون من ستة عناصر في مجموعها تكون المؤسسة، تتنوع بين مادية وبشرية وقانونية، هذه العناصر الستة في مجموعها تكون المؤسسة وهي: الخزانة العامة وفروعها - الجهاز الإداري - الإيرادات - النفقات - الموارد الاقتصادية العامة - حزمة التشريعات (إسماعيل، 2011).

3- الخراج نموذج الابتكار في تطوير مصادر الدخل المالية للدولة:

الخراج اصطلاحاً هو: شيء يخرج القوم في السنة من الماهم بقدر معلوم، وهو أيضاً ما يوضع من ضرائب على الأرض أو على محصولاتها مقابل استغلال الرّزاع لها، أما في الفقه الإسلامي فقد ربط مفهوم الخراج مع الأراضي التي فتحت عنوة، والذي أصبح أهم إيرادات بيت المال فيما بعد (عمر، 2016).

4- بعض صور الابتكار في القطاع الاقتصادي المعاصر:

تعتبر السياسات الفعالة لتطوير وتحديث أدوات المالية الإسلامية أهم ركيزة لبقاء المنظومة المالية الإسلامية وزيادة فعاليتها ونجاحها في السوق المالية، وقد شهدت هذه المنظومة ابتكارات جديدة زادت من القوة التنافسية وحقت أرباحاً كبيرة وقبولاً في السوق المالية العالمية، «فعلى مستوى الابتكارات للأساليب المالية والاقتصادية التي ليس لها نظير في الإقتصاد التقليدي، والذي استطاع الفكر الإقتصادي الإسلامي إنجازها اعتماداً على ما ورد في الفقه الإسلامي من عقود المعاملات،

ومن أمثلتها ما يلي:

1. كيفية التطبيق المعاصر لعقود السلم والاستصناع والمرابحة في النظام المصرفي الإسلامي المعاصر.
2. الاستناد إلى عقد المضاربة في تنظيم العلاقة بين البنك والمودعين وفي تنظيم وثائق صناديق الاستثمار.
3. ابتكار أدوات مالية إسلامية مثل سندات المقارضة و صكوك الإجارة.
4. وثائق التأمين مع المشاركة في الأرباح.
5. إصدار هيئة المحاسبة والمراجعة للمؤسسات المالية الإسلامية للعديد من معايير المحاسبة الإسلامية.
6. سندات أو صكوك الوقف (عمر، 2016).
7. صندوق التقاعد الإسلامي الذي أطلقه بنك HSBC في ماليزيا، ثم ظهور السوق المالية الإسلامية (محمود، 2017).

المطلب الثالث

الآفاق المستقبلية وفق معطيات الواقع والمتوقع للإقتصاد الإسلامي المبتكر في نمط الحياة الإسلامي، وتأثيره على حياة الناس

أولاً: التحديات التي تواجه الابتكارات الاقتصادية الإسلامية:

إن من أهم التحديات التي تواجه الابتكار الإسلامي، هو محاكاته الفكر الإقتصادي التقليدي في بناء التحليل الإقتصادي على مفاهيم مستمدة من النظرة الدنيوية الغربية للحياة والأناية المفرطة وإبعاد الأخلاق والدين عن الإقتصاد، ومن أهم هذه المفاهيم مفهوم الإنسان الإقتصادي الذي يسعى لتحقيق مصلحته دون نظر إلى أثر ذلك على الآخرين، ومفهوم التناسق المزعم الذي يحققه السوق بين المصالح الخاصة والعامة من خلال اليد الخفية،

ومفهوم السعادة الإنسانية المبنية على اللذة الحسية، والوضعية التي تعنى ضرورة استقلال الاقتصاد عن الأحكام القيمة المستمدة من الدين والأخلاق إلى جانب قصر الهدف النظري للفكر الاقتصادي على وصف وتفسير الواقع من أجل إمكانية التنبؤ بما يحدث في المستقبل. ولقد «ثبت بالتحليل المنطقي والواقع الفعلي خطأ هذه النظرة الغربية للحياة وبالتالي التشكك في المفاهيم الأساسية والتي يقوم عليها الاقتصاد الغربي التقليدي، فكيف للفكر الاقتصادي الإسلامي أن تكون له شخصيته المتميزة وهو يقوم على نفس منطق النظام الذي يسعى للحلول محله (عمر، ...).

إن إيجاد أكبر عدد ممكن من أدوات المالية الإسلامية لتلبية الاحتياجات المختلفة للمستثمرين والمقترضين على حد سواء يشكل تحدياً كبيراً للمنظومة المالية الإسلامية الجديدة.

وعلى الرغم من المستوى الذي وصلت إليه الابتكارات في أدوات المالية الإسلامية إلا أن هذه الابتكارات تواجه مجموعة من الصعوبات والعوائق منها ما يتعلق بالموافقة مع الشريعة الإسلامية نتيجة اختلاف التأويلات حسب المدارس الفقهية ومنها ما يتعلق بصعوبة التطبيق على أرض الواقع.

البنوك الإسلامية تواجه تنافساً كبيراً مع البنوك التقليدية، وبالتالي فإن العمل على دعم الابتكارات التكنولوجية وتطويرها لتحقيق المزيد من سهولة الخدمات البنكية للمتعاملين يعتبر خياراً ضرورياً، والعمل من أجل تصميم هذه الابتكارات لتوائم شروط ومتطلبات المالية الإسلامية يعتبر تحدياً حقيقياً، «فمن أجل المنافسة والاستمرارية تحتاج البنوك والمؤسسات المالية الإسلامية إلى تقديم مزيد من الدعم والاهتمام بالابتكارات سواء تلك المتعلقة بأدوات المالية الإسلامية أو تلك المتعلقة بالتسويق أو بالابتكارات التكنولوجية (الأسراج، مجلة الاقتصاد الإسلامي، 2020).

ومن أكثر التحديات التي يواجهها النظام الرقمي في دول الخليج، هو نقص عدد المبتكرين الخليجيين في هذا المجال، فمن بين أكثر من 450 مليون متحدث باللغة العربية، أي 7% من مجموع سكان العالم، لا يشكل المحتوى العربي على شبكة الإنترنت سوى 2% من المحتوى العالمي على الشبكة (محمد، 2016: 23).

إن رأس المال البشري هو حجر الزاوية للاقتصاد القائم على المعرفة، ويمكن القول إنه إذا لم يكن للشباب العربي بشكل عام والخليجي بشكل خاص حضور في التكنولوجيا، فإن أفكارهم وهمومهم والتصاميم التي يرعون فيها في نمط حياتهم لن تشمل عليها السيارات، والبنية التحتية، والطب، والاتصالات وغيرها في المستقبل القريب.

ثانياً: الحلول من أجل ابتكارات اقتصادية فعالة، تدفع بعجلة التطور الاقتصادي، وتضمن الاستقرار العالمي:

من خلال ماتم عرضه من تحديات تواجه القطاع الاقتصادي في عالم جرب الكثير من النظم والاتجاهات الغربية والشرقية التي حاولت أن تكون ملاذاً آمناً للمالية العالمية، والتي لم يدخل نظام منها من إخفاق وخلل، انعكس سلباً على اقتصاد المجتمعات والدول، فظهرت الأزمات المالية العالمية، وظهر الكساد، والفقر والتخلف وغيرها كانعكاسات سلبية لتلك الاتجاهات، كان لزاماً البحث عن الحلول الناجمة لتلك الإخفاقات، ومن تلك الحلول المطروحة:

1. الاهتمام بتفعيل المراكز الأساسية للإسلام في الابتكارات الاقتصادية المأمولة، وهي شعب ثلاث: العقيدة والشريعة والأخلاق، وبالتالي يجب على مبدعي ومطوري الاقتصاد الإسلامي أن تركز ابتكاراتهم على هذه الشعب الثلاث سواء في التحليل الاقتصادي أو وضع النظام الاقتصادي الأمثل.

ومن الجدير بالذكر هنا أن بعض الآليات الاقتصادية التي أثبتت نجاحها كفرصة الزكاة عندما تولت إدارتها الدولة، أثبتت قدرتها على حل مشكلات المجتمع الاقتصادية بجدارة وكفاءة ليس لها نظير، فحري أن يعاد النظر في التمهيدي لعودة دور الدولة في إدارة الزكاة وعودتها أداة اقتصادية فعالة. وكذلك سائر النظم والمراكز الإسلامية للاقتصاد.

2. ليس المطلوب من دراسة الابتكار الاقتصادي هو مجرد التوقف عند حد دراسة ما هو كائن بوصف وتفسير السلوك الاقتصادي الواقعي، بل يجب أن يكون الهدف من الابتكار في الاقتصاد الإسلامي هو تحقيق الرفاهية الإنسانية المطلوبة شرعاً في التوسعة على الناس وجعل الحياة مناخاً مناسباً لهم للاستثمار للأخرة، ولا يكون ذلك في ظل حياة الشظف والعوز والحاجة للأساسيات فقط، ويجب ربط تحقيق هذا الهدف بمقاصد الشريعة الإسلامية، وبالنظر للحاجات المادية والروحية وبالتوازن بين المصلحة الخاصة والمصلحة العامة. ولا عجب أن الحضارات لم تزددهر إلا بوجود مقومات أساسية من أهمها القوة الاقتصادية الفعالة.

3. زيادة الاهتمام بالاستثمار في البحث والتطوير والتعليم، لأن البحث والتطوير يعد أهم عنصر من عناصر الإستراتيجية الوطنية للابتكار، وذلك من خلال زيادة الاستثمارات في كل قطاعات التكنولوجيا المتقدمة الرئيسية. والتعليم قادر على توفير كل الإمكانيات والفرص من أجل ابتكار أفكار وحلول اقتصادية مناسبة لظروف الدول ومواردها، بشكل مبني على البحث العلمي المنهجي.

وإن الأمل معقود على المبتكرين الذين يبتكرون الحلول، ويهندسون الخطط ويصوغون القرارات، ويرسمون خرائط المستقبل في ضوء الحاجات والضرورات والملحاحات، بل الصعوبات والإشكالات والتحديات، لوطن يسر بخطى ثابتة وواقفة نحو مستقبل مشرق، مُستشرفة تحدياته، ومتأهبة ومُستعدة عقول أبنائه لمواجهة مفاجآته. إن التسلح بالمهارات الابتكارية ليس فطرياً، بل هو مكتسب، ومن هنا فإن الاستثمار الحقيقي يكمن في استثمار العقول البشرية المبدعة، والتي تستطيع طي قرون من التأخر الزمني من خلال «الابتكار».

4. ضبط عمليتنا الإنتاج والاستهلاك، ضبطاً ممنهجاً بالآلات مبتكرة، تضمن الوصول بالأسواق لحركة منتعشة نشطة من خال التركيز على توفير السلع الأساسية للبشر والتي لا غنى عنها مثل: الغذاء، والدواء، والمسكن، وخدمات التعليم، والمواصلات، والاتصالات بما سيؤثر على عجلة الإنتاج إلى دورتها الطبيعية، بحيث تكون قادرة على إيجاد الوظائف واستيعاب العاطلين عن العمل.

والابتكار في أساليب الإنتاج للوصول إلى أفضل المنتجات بجودة عالية بأفضل التكاليف الممكنة يجب أن يوازيه توجيه الاستهلاك نحو الانضباط الذي يحمي المجتمعات من الأزمات المالية والبيئية، ويؤذن باستخدامه وأمن اقتصادي بعيد المدى.

5. ضرورة عقد الراكات الدولية لمواجهة التحديات الاقتصادية، خاصة بين دول العالم الإسلامي. فكما أن الشراكة الجوهرية التي تجمع القطاعات الخاصة والعامة في حدود الدول ذاتها من شأنها تعزيز مسارات التنمية البشرية والاقتصادية؛ فإن العالم الإسلامي بما يحويه من مقومات النمو الاقتصادي يمكن أن يحقق مفتاحاً لمزيد من الاستقرار والتنمية في عالمنا إذا نجح في بناء الشراكات بين

دوله من جهة ودول العالم من جهة أخرى، وذلك بالإفادة من اختلاف مواردها وتطوير أنظمة التعاون بينها، مع الاستمرار في تطوير خدمات إسلامية تتناسب مع التنمية في العصر الراهن.

6. إنشاء "مراصد الاستشراف الاقتصادي" التي تقوم بتتبع المتغيرات والتي تستطيع أن تقدم رؤى مستقبلية (باستعمال وسائل الاستشراف وعلم المستقبلات) والتي تمكن من اتخاذ القرارات السليمة التي توصل إلى المستقبل المرغوب والمستدام، على غرار دور "يوسف" عليه السلام الذي رسم السيناريوهات المحتملة للوقوع، واليوم الدول العربية -خاصة المصدرة للبترول منها (الاقتصاديات الربعية) - هي أحوج لدراسة استشرافية من النمط الإسلامي «المذكور في قصة يوسف عليه السلام» تحلل تاريخها، وتنبئ حاضرها وترسم (أو تصنع) مستقبلها خصوصاً ما يعرف: «سيناريوهات ما بعد البترول» (السنوات العجاف) (المرزوقي، 2018: 22).

الخاتمة

تناولنا في هذا البحث مفهوم الابتكار في الإسلام ومنهجية إدارته في المؤسسات المعاصرة، وقد اتضح لنا أن الابتكار يُعدُّ من أهم القدرات التي يجب أن تحظى بالاهتمام والعناية والرعاية، وفي الوقت الراهن أصبح الاهتمام بالابتكار بوجه عام والابتكار الاقتصادي بوجه خاص ضرورة تحتمها طبيعة العصر الحديث كونه يدخل ضمن كافة مجالات الحياة، أما الابتكار الاقتصادي فهو المقدر على تطوير فكرة أو عمل أو تصميم أو أسلوب أو أي شيء آخر وبطريقة أفضل وأيسر وأكثر استخداماً وجدوى، وهناك ليس كبير بين الابتكار والإختراع عند عموم الناس، ويؤدي الابتكار الاقتصادي إلى منتج جديد ليس مجرد وهم، وجديد لا يعني أنه اكتشاف، ولكن تكميل على من بدأ، أو تعديل في شيء، أو تغيير في أسلوب الأداء فهو (التراكم) وهو ليس اختراعاً، فعندما يقوم أحد الباحثين بالابتكار فكرة، ويتم استغلال هذه الفكرة من قبل المؤسسة التي يعمل بها، وتستطيع المؤسسة تحويل هذه الفكرة إلى منتج جيد أو خدمة متميزة، فإن ذلك يُعدُّ من قبيل الاكتشاف وليس اختراعاً. وعندما سُئل أحد النحاتين: كيف يبدع هذه النماذج المنقطة؟ قال: إنني لا أخلق من عدم، ولكني أكتشف ما هو موجود أصلاً.

والابتكار في الفكر الإسلامي يُقصد به: الابتكار في المؤسسات الإدارية، من حيث قدرة المؤسسات المالية والاقتصادية على تحقيق رغبات زيناتها والمستثمرين فيها بشكل سريع وفعال مع الأخذ بالأخذ بالاعتبار التغيرات التي تطرأ على السوق ومواكبتها بشكل دائم، وذلك وفق النظم والأطر الإسلامية الشرعية التي تميز وسائل الابتكار وغاياته وأدواته وطرق تطبيقه، بخلاف الأنظمة الوضعية الأخرى، والفقه الإسلامي غني بالصور الفقهية التي تمثل سياسات بديلة لكيفية ممارسة المعاملة، وفي ظل ظروف وافتراضات متعددة، بعضها جاء بعد استقراء الواقع، والآخر جاء استشرافاً للمستقبل، وهذا ما يفيد المفكر الاقتصادي في متابعته لدراسة المستجدات، ويستطيع من خلاله أن يقوم بعملية الابتكار للمنتجات أو النظم، أو الحلول الاقتصادية، والمشكلة الاقتصادية الأساسية التي يعمل الفكر الاقتصادي على حلها هي كيفية التوفيق بين الموارد المحدودة والحاجات المتعددة، والرأسالية خلصت إلى أن الآلية التي تحقق ذلك هي أسعار السوق، فالأفراد أحرار في تحديد ما ينتجون كما ونوعاً لتحقيق أقصى ربح ممكن في ضوء ما تسمح به أسعار السوق.

إن الابتكار سمة الدين الإسلامي الذي يحب التميز ولا يحب التقليد والمتابعة للأنظمة الأخرى على غير هدى، وينعكس في المجال الاقتصادي على عدم إتباع سياسة القطيع في السوق باتباع سلوك الشركات القائدة.

قائمة المصادر والمراجع

أولاً: قائمة المصادر والمراجع العربية:

- ثانياً: قائمة المصادر والمراجع الأجنبية:
- (1) A. Van Vaerenbergh, Regulatory Features and Administrative Law Dimensions of the Olympic Movement's Anti-Doping Regime, IILJ Working Papers 2005/11, New York University Law School, spec.
 - (2) Al-Jalal Ibrahim & Kurdi, Manal Mohamed, "Introduction to Management Information Systems: Theory tools applications" Press, University House, Alexandria, in 2000.
 - (3) Anat Arkin, Personnel Management in Germany, At Work in the Powerhouse of Europe, Personnel Management 24, no. 2, February 1992.
 - (4) B. Dalle, The Global Aspirations of the Aarhus Convention and the Case of the World Bank, paper presented to the Second Global Administrative Law seminaer, Viterbo, 9-10 June 2006.
 - (5) Borins, S.: The new public management is here to stay. Canadian public Administration, 1995.
 - (6) G. Handl, International "Lawmaking" by Conferences of the Parties and Other Politically Mandated Bodies, in R. Wolfum-V. Röben (eds.), Developments of International Law in Treaty Making, Springer, Berlin, 2005.
 - (7) 2004. „Joan Pynes: Human resources management for public and nonprofit organizations
 - (8) K. Murphy, Regulating More Effectively: The Relationship between Procedural Justice, Legitimacy, and Tax Non-compliance, in Journal of Law and Society, vol. 32, n. 4, December 2005.
 - (9) Lynda Gratton :Strategic Human Resource Management: Corporate Rhetoric and Human Reality, 1999.
 - (10) M. Howlett and J. Rayner, Globalization and Governance Capacity: Explaining Divergence in National Forest Programs as Instances of "Next-Generation" Regulation in Canada and Europe, in Governance, vol. 19, n. 2, April 2006.
 - (11) Paul J. Fortier, Howard Edgar Michel: Computer Systems Performance Evaluation and Prediction, Enterprise computing series, Digital Press, 2003.
 - (12) R. A. Gorman, The Development of International Employment Law: my Experience on International Administrative Tribunals at the World Bank and the Asian Development Bank, in Comp. Labor Law and Pol'y Journal, 25, 2004.
 - (21) ابن حزم، ب.ت). رواه ابن حزم بسنده إلى عمر بن الخطاب رضي الله عنه، المحلى، لابن حزم.
 - (22) أبو شقمة، عزة، ياسين، رزان سعيري الشيخ (2010). أثر التنمية الإدارية على الأداء الوظيفي بالوزارات الحكومية العاملة في محافظة نابلس، رسالة ماجستير، كلية الاقتصاد والعلوم الإدارية، جامعة النجاح الوطنية، نابلس.
 - (23) الأسرج، حسن عبد المطلب (2020). مستقبل المصارف الإسلامية في ظل التقدم التكنولوجي، حسن عبد المطلب الأسرج، مجلة الاقتصاد الإسلامي العالمية، <https://giem.kantakji.com/article/details/ID/555>.
 - (24) إسماعيل، محمد إسماعيل محمد (2011). الخراج في عهد الخليفة عمر بن الخطاب، دراسة تحليلية في الجذور والتطور، رسالة ماجستير.

- (25) البياز، هبة محمود الطنطاوي (2003). التطورات العالمية وتأثيرها على العمل المصرفي وإستراتيجية عمل البنوك في مواجهتها مع إشارة خاصة لمصر، رسالة ماجستير في الاقتصاد، كلية التجارة، جامعة عين شمس، القاهرة.
- (26) بلوط حسن إبراهيم (2005). الاتجاهات الحديثة في إدارة المؤسسات، دار النهضة العربية، بيروت.
- (27) بن عاشور، الطاهر (2004-2005). أصول النظام الاجتماعي في الإسلام، الطاهر بن عاشور، الشركة التونسية للتوزيع، تونس، ط(2).
- (28) الجرجاني، علي بن محمد بن علي (1405هـ). التعريفات، تحقيق: إبراهيم الأبياري، دار الكتاب العربي - بيروت، ط(1)، 1405هـ.
- (29) جودة، محفوظ أحمد (2008). تطبيق نظام قياس الأداء المتوازن وأثره في الالتزام المؤسسي للعاملين في شركة الألوينيوم الأردنية، المجلة الأردنية للعلوم التطبيقية، المجلد 11، العدد 2، عمان.
- (30) الحبيشي، سمير عبد الله قسم (2008). الدوران الداخلي للموظفين وأثره على أدائهم، دراسة ميدانية في شركة ناككو المحدودة، رسالة ماجستير، جامعة العلوم والتكنولوجيا، صنعاء.
- (31) حريم، حسين محمود (2013). إدارة الموارد البشرية، دار الحامد للنشر والتوزيع، عمان.
- (32) الحسن، خليفة بلبكر (2016). ضوابط الاستهلاك وحماية المستهلك في الشريعة الإسلامية، صحيفة الاقتصاد الإسلامي <http://www.aliqitadalisalami.net>
- (33) حسن، روية (1998). السلوك التنظيمي المعاصر، الطبعة الأولى، دار الجامعية للطباعة والنشر، الإسكندرية.
- (34) الحسينية، سليم إبراهيم (2009). الإدارة والإبداع، المنظمة العربية للتنمية الإدارية، دمشق.
- (35) الحنوي، محمد صالح، العبد، جلال إبراهيم (2005). بورصة الأوراق المالية بين النظرية والتطبيق، دار الجامعية، الإسكندرية.
- (36) الحنبلي، عبد الرحمن بن أحمد بن رجب (1405هـ). الاستخراج لأحكام الخراج، دار الكتب العلمية - بيروت، ط(1).
- (37) حنفي، عبد الغفار (1995). البورصات "أسهم، سندات، صناديق الاستثمار"، المكتب العربي الحديث، الإسكندرية.
- (38) الحوراني، ياسر عبد الكريم (2000). في مصادر التراث الاقتصادي الإسلامي، ياسر عبد الكريم الحوراني، (171)، مجلة: إسلامية المعرفة، العدد (20).
- (39) سلطان، محمد سعيد (2002). السلوك الإنساني في المنظمات، دار الجامعة الجديدة، الإسكندرية.
- (40) سليمان، محمد أحمد، وهب، سوسن عبد الفتاح (2011). الرضا والولاء الوظيفي "قيم وأخلاقيات العمل"، زمزم للنشر، عمان.
- (41) سويلم، سامي (2004). صناعة الهندسة المالية نظرات في المنهج الإسلامي، د. سامي سويلم، مركز البحوث، شركة الراجحي المصرفية للاستثمار، رمضان 1425 هـ ديسمبر.
- (42) الطمخ، عبد الله، السواط طلق (2010). السلوك التنظيمي، دار حافظ للنشر والطباعة، جدة.
- (43) الطراونة، تحسين أحمد (2012). الفلسفة الأخلاقية وعلم القيادة وتطبيقاتها في قيادة فرق العمل الأمنية، جامعة نايف العربية للعلوم الأمنية، الرياض.
- (44) عوي، زيد منير (2006). إدارة الإبداع والابتكار، دار كنوز المعرفة، عمان، الطبعة الأولى.
- (45) عموي، ختام عارف حسن (2010). دور الزكاة في التنمية الاقتصادية، ختام عارف حسن عموي، رسالة ماجستير.
- (46) عمر، محمد عبد الحليم (ب.ت). التجديد في الفكر الاقتصادي الإسلامي، مؤتمر المجلس الأعلى للشؤون الإسلامية، الدورة (13)، مصر <http://webcache.googleusercontent.com>
- (47) عمر، محمد عبد الحليم (ب.ت). التجديد في الفكر الاقتصادي الإسلامي، جامعة الأزهر، القاهرة.
- (48) قططجي، سامر (2005). ضوابط الاقتصاد الإسلامي في معالجة الأزمات المالية العالمية.
- (49) قططجي، سامر (2005). مشكلة البطالة وعلاجها في الإسلام، مؤسسة الرسالة.
- (50) الموردي (ب.ت). الأحكام السلطانية، بيروت
- (51) مجلس التجارة والتنمية (2013). الاستثمار والابتكار والتكنولوجيا من أجل التنمية، لجنة الاستثمار والمشاريع والتنمية، مؤتمر الأمم المتحدة للتجارة والتنمية، الدورة الخامسة، جنيف، في الفترة من 29 أبريل - 3 مايو.
- (52) محمد، نيفين حسن (2016). دور الابتكار والإبداع المستمر في ضمان المركز التنافسي للمؤسسات الاقتصادية والدول، «دراسة حالة دولة الإمارات»، نيفين حسن محمد، وزارة الاقتصاد، إدارة التخطيط ودعم القرار.
- (53) محمد، نيفين حسن (2016). دور الابتكار والإبداع المستمر في ضمان المركز التنافسي للمؤسسات الاقتصادية والدول، «دراسة حالة دولة الإمارات»، نيفين حسن محمد، وزارة الاقتصاد، إدارة التخطيط ودعم القرار، أبوظبي.
- (54) محمود، محمد (2017). مقال: تطوير الابتكارات في المالية الإسلامية، الإمام محمد محمود، <https://islamonline.net>
- (55) المرزوقي، محمد (2018). الابتكار في الاقتصاد الإسلامي روح التطور الاقتصادي، وضمة الاستقرار العالمي. بحث في كتاب بحوث منتدى فقه الاقتصاد الإسلامي الرابع، دائرة الشؤون الإسلامية والعمل الخيري ببني.
- (56) مليك، سارة، بزرجم، لمياء (2010). تمويل الإبداع في المؤسسات الصغيرة والمتوسطة، مذكرة ليلس في العلوم الاقتصادية، جامعة قاصد مرياح ورقلة، الجزائر.
- (57) النتيقات، محمد بن عامر (2006). المتغيرات التنظيمية وعلاقتها بمستوى الإبداع الإداري في الأجهزة الأمنية، رسالة ماجستير في العلوم الإدارية، جامعة نايف العربية للعلوم الأمنية، الرياض.
- (58) هندي، منير إبراهيم (2003). الفكر الحديث في إدارة المخاطر "الهندسة المالية باستخدام التوريق والمشنتات المالية"، الجزء الثاني، منشأة المعارف، الإسكندرية.

تأثير الانماط القيادية على التنمية المستدامة في قطاع الصناعات الكيماوية بسلطنة عمان

خالد سعيد عوض فاضل

جامعة العلوم الاسلامية الماليزية

ماليزيا

ملخص: ان اداء اي مؤسسة يعتمد الى حد كبير على اداء قادتها. ذلك ان القيادة الفعالة تترجم إلى صياغة وتنفيذ سياسة مؤسسية حكيمة. مازال القطاع الصناعي العماني يفتقر الى خطة صناعية شاملة، التي تواكب النمو الاقتصادي من خلال تنوع الصناعات المحلية، بدلا من تركيزها في صناعات معينة ومحدودة. تهدف هذه الدراسة الى قياس اثر الانماط القيادية على التنمية المستدامة في قطاع الشركات الكيماوية بسلطنة عمان. اتبعت الدراسة المنهج الوصفي التحليلي لقياس اثر ثلاثة انماط قيادية ممثلة في القيادة التحويلية والرسمية والتبادلية على عامل التنمية الاقتصادية في ظل مفهوم التنمية المستدامة. شملت عينة الدراسة 285 موظفا من قطاع الشركات الكيماوية بسلطنة عمان. أظهرت النتائج وجود اثر ايجابي ذو دلالة احصائية لكل من القيادة التحويلية والتبادلية، كما اكدت على عدم وجود اي اثر ذو دلالة احصائية للنمط القيادي الرسمي على التنمية الاقتصادية في ظل مفهوم التنمية المستدامة. توصي الدراسة بتبني النمط القيادي التحويلي نظرا لاعتمادة على الرؤى في المدى الطويل، الذي يتناسب مع اهداف التنمية المستدامة المقررة من حكومة السلطنة.

الكلمات المفتاحية: القيادة التحويلية، القيادة التبادلية، القيادة الرسمية، التنمية الاقتصادية، التنمية المستدامة.

1. المقدمة

ان اداء اي مؤسسة يعتمد الى حد كبير على اداء قادتها. ذلك ان القيادة الفعالة تترجم إلى صياغة وتنفيذ سياسة مؤسسية حكيمة ، وكذلك تقديم خدمات تلامس تطلعات جمهورها. كما يجب ان يكون سقف هذا الاداء بما يضمن عدم ضرر اصحاب المصلحة في العموم، فتغليب مصلحة المنظمة على مصلحة المجتمع الذي يعد جزء منه، قد يعود بالضرر على المنظمة ذات نفسها في الاجل الطويل. اشار (Di Fabio, 2017) الى ان المنظمات التي باتت تولي عناية خاصة بالمجتمع من حولها اصبحت اكثر قدرة على الاستمرار والنمو مقارنة بغيرها من المنظمات التي لم تترك ذلك. يقودنا هذا الى التساؤل عن اهم الركائز التي تقوم عليها مصلحة المجتمع. اجمعت دول العالم في مؤتمر الأرض عام 1992 على تعريف هذا المفهوم من خلال التنمية المستدامة والذي عرف بأنه "ضرورة تحقيق التنمية على النحو الذي يشبع الحاجات التنموية والبيئية للأجيال الحاضرة والأجيال المستقبلية أيضا". وقد بزغ هذا المفهوم بوصفه فلسفة تنموية جديدة قائمة على مبدأ الاستدامة، فالهدف منها هو القضاء على الانماط الانتاجية والاستهلاكية الحالية سواء في الدول المتقدمة أو الدول النامية والاحذة في النمو والاستعاضة عنها بأنماط إنتاجية واستهلاكية تحافظ على البيئة وعلى موارد هادون استنزاف ودون إهدار، والمحافظة على حقوق الأجيال القادمة في الاستفادة من تلك الموارد أيضا. حيث قدمت اللجنة العالمية للبيئة والتنمية تعريف للتنمية المستدامة "بأنها هي تلك التنمية التي ، تحقق وتلبي الحاجات الأساسية للجميع وإتاحة الفرص أمامهم لتحقيق طموحاتهم في حياة أفضل، مع نشر وتشجيع أنماط إنتاجية واستهلاكية ضمن الحدود وإمكانيات البيئية التي يتطلع المجتمع الى تحقيقها بشكل معقول".

2. مشكلة الدراسة

واكبت سلطنة عمان ببقية دول العالم باللاحق بركاب تحقيق التنمية المستدامة. في هذا الصدد حدد المجلس الأعلى للتخطيط في السلطنة في عام 2015م 17 هدفا في سبيل تحقيق الأهداف الاممية للتنمية المستدامة بحلول العام 2030م (الالكترونية، 2019). وفقا للتقرير الوطني الأول للسلطنة تمكنت سلطنة عمان من تحقيق 14 هدفا حتى العام 2018م، وتندرج الاهداف المتبقية التي لم يتم تحقيقها، بتلك القضايا المرتبطة بالتنمية البيئية، التي ترتبط ارتباطا وثيقا بالتزامات القطاع الصناعي العماني تجاه هذه الاهداف (Harrower & Nathan, 2018). وقد نجحت السلطنة في تحقيق الأهداف 14 التي تم تحديدها ضمن أهداف التنمية المستدامة للأمم المتحدة 2030 في كل من القضاء على الفقر والقضاء التام على الجوع والصحة الجيدة والرفاه والتعليم الجيد والمساواة بين الجنسين والمياه النظيفة والصحية وطاقة نظيفة وبأسعار معقولة والصناعة والابتكار والهيكل الأساسية وعمل مدن ومجتمعات محلية مستدامة والعمل المناخي والحياة تحت الماء، وعقد الشراكات لتحقيق الأهداف.

حرصت السلطنة منذ العام 2015م على إدماج أبعاد وأهداف التنمية المستدامة في خطط واستراتيجيات التنمية في عُمان وفي مقدمتها الخطة الخمسية التاسعة (2016 – 2020) ورؤية عُمان 2040، وقد اعتمدت السلطنة في سبيل تحقيق هذه الاهداف اشراك العديد من القطاعات كشركاء لتحقيق التنمية المستدامة، مثل قطاع الصناعة في السلطنة الذي يعد من اهم هذه القطاعات، ذلك نظرا لارتباطه الوثيق بتحقيق هذه الاهداف باعتباره من اهم القطاعات مشاركة على المستوى الاقتصادي والبيئي. حيث بلغت مشاركة هذا القطاع الى الناتج المحلي الاجمالي للسلطنة الى 12% في العام 2018 وفقا لتقارير الصادرة من المركز الوطني للاحصاء، ويعد ثاني اكبر قطاع مساهمة بعد قطاع النفط، تستهدف السلطنة رفع حصة مشاركة القطاع الصناعي الى 15% بحلول العام 2020م. إلا ان مدى التزام القطاع الصناعي العماني تجاه اهداف التنمية المستدامة لم يلقى الاهتمام الكامل من القطاع، يعود ذلك الى تضارب بعض المصالح الخاصة بالقطاع مع اهداف التنمية المستدامة، حيث يعد الالتزام بحجم الانبعاثات الكربونية من قطاع الانتاج الصناعي احد اهم الامثلة على هذا التضارب في المصالح.

فيما يتعلق بالهدف الثامن من اهداف التنمية المستدامة الخاص بالعمل اللائق ونمو الاقتصاد، مازال القطاع الصناعي العماني يفتقر الى خطة صناعية شاملة، التي تواكب النمو الاقتصادي من خلال تنوع الصناعات المحلية، بدلا من تركيزها في صناعات معينة ومحدودة، كالاستثمار في الطاقة المتجددة (Maksood & Achuthan, 2017)، البناء الاخضر (Nasrollahi, Hashemi, Bameri, & Taghvaei, 2018)، وتبني مفهوم الثور الصناعية الرابعة (Shamsuzzoha, Al-Kindi, & Summad).

نظراً لأن بيئة العمل تتغير بسرعة وتصبح تنافسية شديدة، فقد أصبح من الضرورة الاعتماد على قادة قادرين على تحسين الاداء وتطويره للبقاء وكذلك للنمو المستدام. وبالتالي، يواجه قطاع الصناعة في سلطنة عمان تحديا هاما يتمثل في ايجاد قادة قادرين على الموازنة بين تحقيق الاداء عالي ونمو مستدام (Nguyen, Tanner, & Pham, 2019). أكدت عزة المسكري واخرون (Al-Maskari et al, 2019). على أن تكوين أنظمة صناعية

متوازنة إيكولوجياً في سلطنة عمان أمر حاسم بالنسبة للمدن الصناعية ، مما يشكل تهديداً خطيراً لمبادرات التنمية المستدامة المحلية والعالمية. إن غالبية التحديات المدرجة من قبل الشركات الصناعية في سلطنة عمان تشمل المشاكل المتعلقة بالالتزام البيئي، ذلك نتيجة للتكلفة العالية التي تتحملها هذه الشركات في سبيل تحقيق أهداف الاحتياجات البيئية (Safinia et al., 2017). أن تحقيق أهداف التنمية المستدامة مرتبط بالقيادة القائمة على فهم الممارسات الثقافية للقطاع الصناعي وتخصيصها وتحولها ، من خلال العمل على إعادة النظر في الثقافة التنظيمية المتصلة بأهداف التنمية المستدامة. أكد جالبين (Galpin, 2017) الدور الهام الذي يتولاه قادة المنظمات نحو تحقيق التنمية المستدامة من خلال بناء القيم والسلوكيات التي تتناسب مع تحقيق استراتيجية التنمية المستدامة، والعمل على أن تكون من ضمن الأهداف الرئيسية للمنظمات الربحية الصناعية. بالرغم من كل محاولات سلطنة عمان و العاملين في السلطنة في مجال الشركات الصناعية على تحقيق التنمية المستدامة، إلا أن السلطنة لم تستطع تحقيق التنمية المستدامة على أتم أشكالها. تكمن مشكلة الدراسة الحالية في إيجاد معرفة ماقد يحقق التنمية المستدامة في السلطنة في المجال الصناعي. عليه، يسعى الباحث من خلال الدراسة الحالية إلى معرفة مدى تأثير الأنماط القيادية على التنمية المستدامة.

3. أهداف الدراسة

تهدف الدراسة الحالية إلى تحقيق الأهداف التالية:

- 1.0 معرفة مدى تأثير القيادة التحويلية على التنمية المستدامة في قطاع الشركات الكيماوية بسلطنة عمان.
- 2.0 معرفة مدى تأثير القيادة التبادلية على التنمية المستدامة في قطاع الشركات الكيماوية بسلطنة عمان.
- 3.0 معرفة مدى تأثير القيادة الرسمية على التنمية المستدامة في قطاع الشركات الكيماوية بسلطنة عمان.

4. الاطار البحثي

تقدم الدراسة الحالية الاطار البحثي التالي:

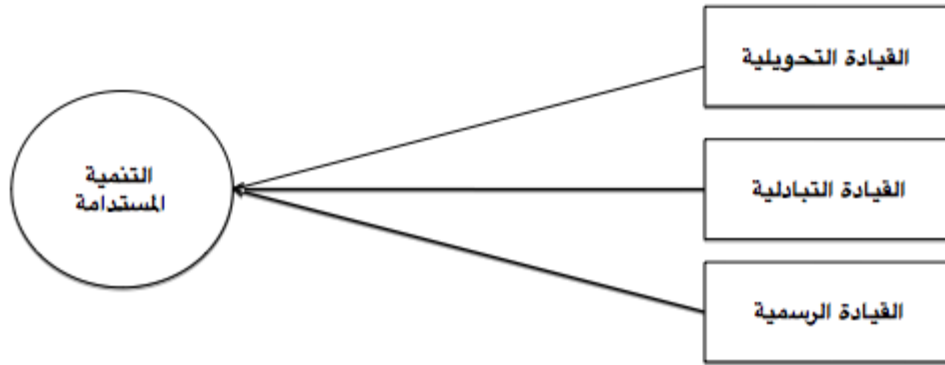

5. مراجعة الأدبيات

إن القيادة لا يمكن أن تزدهر في الفراغ ، مما أكدت جميع نظريات القيادة الحديثة أن القيادة الفعالة هي إنتاج التفاعل مع القائد المرتبط بالقائد تحت دوراً رئيسياً في مسؤولية الإنتاج الأفراد الذين يعملون معه.

وبالتالي ، نجد أن القائد هو مسؤولية تحقيق الأداء الفعال والفعالية بأقصى طاقة ممكنة وأقل تكلفة. وبالتالي ، يمكننا التأكيد على أهمية دراسة أنماط القيادة ، حيث تشكل الطريقة والطريقة التي تتعامل بها مع رؤوسه ، حيث يكون القائد هو نوع القيادة العامل الرئيسي في نجاح أو فشل المؤسسات في المؤسسات العامة والتعليمية ، على وجه الخصوص ، لم يكن ذلك قائداً لدور حاسم في سلوك المعلمين في توفير جو علمي فعال في المدرسة (لبيدة، 2016).

يجب أن يكون القائد مدرراً تماماً أن الممارسات التي يقوم بها الفكر هي الأفضل ، والتي تحقق ما هو أفضل للطلاب ، وتلك التي ينبغي أن تخلق نموذجاً للتأكيد على أهمية العلاقات القائمة على العدالة والرعاية ، ويجب فهمها القائد أن هذه الإجراءات لها عواقب على النظام بأكمله ، وفهم هذه الأشياء سيمنح الفرصة لأي قائد للتعاون مع جميع المشاركين في التعليم السلكي ، وهذا يؤكد أن المدرسة ستعكس أهداف المجتمع في الانتشار ، ومساعدة الشباب في المجتمع ، لتحقيق إمكاناتهم ويصبحوا الشباب هنا يبركون تماماً. لقد ارتبطوا بالآخرين داخل شبكة العلاقات المعقدة. تشير الدراسات إلى أن تكوين الرؤية هو أهم عناصر القيادة التحويلية. تسليم الرؤية للمتابعين. ما هي قيمة الرؤية مهما كانت رائعة ومرغوبة إن لم يكن ما يصل إلى أتباع مفهوم واضح والإيمان بها؟ القائد الفعال قادر على تقديم رؤية للطريقة التي يتبعها المقنعون العاطفيون ويوضحونهم ويؤمنون بها ويحمسون لها ويسرعون في العمل لتحقيقها والتضحية من أجلها.

إن القائد الذي يسعى إلى احترام التابعين وتفاعلهم معه لا يفسر الرؤية فحسب ، بل يطبقها ويطلبها. لم يعد من المقبول أن نعيش في قائد برج عجي وأتباعه حول المستقبل يحدث والأمال والأحلام. الزعيم المقترض للتابعين للعيش بين المباراة والتأكد من أن كل العمل مع هذه الرؤية والقيم والمبادئ (غابرييل ، 1970).

لدراسة العلاقة المحتملة بين التوجه الثقافي للمؤسسة والسعي إلى تحقيق مبادئ استدامة الشركات، نراجع ونستكشف مفهوم استدامة الشركة. نشير إلى أنه على الرغم من أن هذا المفهوم قد حظي بالكثير من الاهتمام في الدراسات التنظيمية والإدارية الحديثة، لا يزال هناك القليل من التنصير حول كيفية تحقيق ممارسات الاستدامة المؤسسية داخل المنظمات. علاوة على ذلك، فإننا نوضح كيف أن مفاهيم استدامة الشركات والنقطة التنظيمية تشترك في أوجه التشابه عبر مختلف الأبعاد وتوفر أساساً مفاهيمياً لإجراء تحليل أكثر شمولاً للتغيير الثقافي المتصل بالاستدامة. ينشأ مفهوم استدامة الشركات عن المفهوم الأوسع للاستدامة، والذي تم تشكيله من خلال عدد من التأثيرات السياسية والعامية والأكاديمية على مر الزمن (Kidd، 1992). وتشمل هذه التأثيرات حركة الحفاظ في أوائل القرن العشرين، وحركات البيئة والتكنولوجيا المضادة في 1960s و 1970s (على سبيل المثال، بن دايفيد، 1975؛ Farvar & Milton، 1972)، فلسفة "عدم النمو" التي ظهرت في 1970s (على سبيل المثال، دالي، 1974؛ ميدوز، راندرز، وبيرينز، 1972)، وكذلك مساهمات من علم البيئة (على سبيل المثال، ريدل، 1981). خلال الثمانينات، أصبحت القضايا الاجتماعية أكثر بروزاً، بما في ذلك حقوق الإنسان ونوعية الحياة بالإضافة إلى الفقر، خاصة في البلدان الأقل نمواً (Shama، 2005 & Arago'n-Correa). زاد الضغط العام من أجل مناهج جديدة للبيئة والتنمية، ولإدماج الحماية البيئية مع تطور من شأنه أن يؤدي في النهاية إلى تخفيف حدة الفقر.

أصبح مفهوم الاستدامة معروفاً على المستوى العالمي من خلال تقرير "مستقبلنا المشترك" الصادر عن اللجنة العالمية للبيئة والتنمية (WCED) (1987)، وهو كيان للأمم المتحدة المعروف أيضاً باسم لجنة بروندتلاند. تتعلق الاستدامة المرتبطة بـ WCED بالسلامة البيئية والعدالة الاجتماعية، وأيضاً للشركات والازدهار الاقتصادي من خلال صياغة مصطلح التنمية المستدامة، الذي يُعرف باسم "التنمية التي تلبى احتياجات الحاضر دون المساس بقدرة الأجيال المقبلة على تلبية احتياجاتها الخاصة" (WCED، 1987، ص 43). أسفرت قمة الأرض لعام 1992 في ريو دي جانيرو عن قبول واسع النطاق لهذا التعريف من قبل قادة الأعمال والسياسيين والمنظمات غير الحكومية (Dylick & Hockerts، 2002). بالنسبة للمنظمات، فإن ذلك ينطوي على التحدي المتمثل في تحسين الرعاية الاجتماعية والإنسانية في نفس الوقت مع تقليل تأثيرها البيئي وضمان تحقيق الأهداف التنظيمية بفعالية (شارما، 2003).

5.1 القيادة التحولية

أسلوب القيادة التحولي، والذي يُعرف أيضاً باسم القيادة الداعمة، هو أسلوب القيادة السليم والمثالي الذي يفضلهُ الموظفون في إحدى المؤسسات (Baah، 2015). يعد أسلوب القيادة هذا عاملاً محفزاً للموظفين، حيث يتحدون الموظفين لتحقيق الأهداف التنظيمية بالإضافة إلى ذلك، نتيج طبيعتها لتطوير الموظفين التطوير التنظيمي عبر الأهداف التنظيمية. حيث يمثل هذا الهدف تحقيقاً لزعيم تحولي (ع. إ. محمد & أبوسن، 2009). عرف (Birasnav، 2014) القيادة التحولية على أنها العلاقة القائمة بين القائد والموظف. تصور العديد من السلوكيات الشخص كقائد تحولي. وهي راندة تتمتع بنفوذ مثالي وحافز ملهم وموفر للحفز الذهني ومراعاة فردية تجاه الموظفين (Yaghoubipoor، Tee، & Ahmed، 2013). على النقيض من ذلك، فإن أسلوب القيادة التحولية هو الثقافة الابتكارية في إحدى المؤسسات إلى جانب الأداء المؤسسي، في حين أن (Ivey & Kline، 2010)، والذي تم تعزيزه أيضاً من خلال الإشارة إلى أن قادة التحولات يميلون إلى التركيز أكثر على رفاهية الموظفين واحتياجاتهم ودوافعهم. بشكل عام، تتألف القيادة التحولية من أربعة عناصر رئيسية هي (Avolio، 1999، Bass and Jung)، تأثير مثالي حيث يرى الموظفون القادة كنموذج يحتذى به، والدافع الملهم، حيث يحفز القادة الموظف من خلال الالتزام والعمل الجماعي، والتحفيز الفكري حيث يسمح للقادة للموظفين أن تكون مبتكرة والتفكير النقدي واعتبار فردي، حيث يركز القادة على احتياجات الموظفين.

5.2 القيادة التبادلية

تتكون القيادة من العلاقات المتبادلة. هناك، على الأقل، جانبان للعلاقات المتبادلة، أحدهما إيجابي والآخر سلبي. العلاقات المتبادلة إيجابية لكل من القادة والمساهمين عندما تكون متبادلة وتعاونية. يحدث الجانب الإيجابي الأول لعلاقات القيادة المتبادلة عندما يستفيد جميع المشاركين (Lussier & Achua، 2015). تساعد أوزة الرصاص على كسر قوة الرياح الرأسية وتجعل من السهل على الأوزال التالية عدم بذل الكثير من الجهد. الجانب جنباً إلى جنب من القيادة هو أن يحدث دوران للموضوع الأمامي في تشكيل "V". إنه متبادل لأن كل الأوز في القطيع يستفيدون من هذا التعاون المنظم.

الجانب الثاني للقيادة المتبادلة هو عندما يكون سلوك التابع معكوساً ومعارضاً لقادة الأداء العام. عندما يقوم القائد بحل المشكلات لجميع أتباعه، يفقد المتابعون تدريجياً القدرة على حل المشكلات بأنفسهم. لقد اشنتكي لي العديد من القادة الاستبداديين الذين أداروا عملية اتخاذ القرارات الدقيقة لموظفيهم من أن موظفيهم يتصرفون مثل الأطفال ويفتقرون إلى الانضباط للقيام بأبسط المهام (Saleem، 2015).

كانت الحقيقة أن الموظفين تصرفوا مثل الأطفال. لقد كان أداءهم غير كافٍ كجزء من دورهم العكسي والعكس في العلاقة المتبادلة مع زعيمهم. من المرجح أن يخلق القادة من أعلى إلى أسفل دور التبعية الناقص الأداء عن دور القادة جنباً إلى جنب. تشبه العلاقة العكسية جزء قطعة اللغز الذي يبرز بشكل مرح ويحتاج إلى المساحة الفارغة المقابلة في قطعة لغز أخرى لتتناسب. أنظمة القيادة العاطفية تشبه قطع الألغاز التي تتوافق مع بعضها البعض (Smith، 2015).

فائدة واحدة من نموذج نظم القيادة هو أن هناك المزيد من نقاط الدخول لتحسين نتائج النظام. في الحالة المذكورة أعلاه، لدى القادة خيار جديد ليس فقط بالنظر إلى الأداء المتدني لأتباعهم، بل يمكنهم أيضاً البدء في مراقبة وتجربة كيفية إسهام سلوكهم المفرط في الأداء في ظل هذا الأداء. عندما تتم ترقية الأفراد إلى مناصب إدارية، يكون هناك ميل لاختيار الشخص الأكثر صعوبة والأذكى في الوظيفة لسوء الحظ، قد يكون لدى القائد الذي يعمل بجد أكبر ميل للقيام بعمل الآخرين وتفكيرهم. عملت مجموعة من القادة الذين تشاورت معهم باستمرار في وقت متأخر من الليل واشتكوا من أن العمال سحقهم للخروج من المكتب في أوقات متأخرة مساءً. إن معرفة العلاقات المتبادلة للقيادة تحل لغز لماذا تكون وحدات العمل لأصعب وأقوى رؤساء العمل في بعض الأحيان تتمتع بأدنى أداء وأرباح (Haq & Kuchinke، 2016).

5.3 القيادة الرسمية

يُنظر إلى أسلوب القيادة في الرسمية او المعاملات والذي يُعرف أيضاً باسم القيادة التوجيهية على أنه اتفاق بين كل من القائد والموظف، حيث يُمكن تحقيق هدف معين أو تحقيق الهدف من تحقيق العلاقة بين الطرفين (Baah، 2015). وتُعرف قيادة المعاملات المعروفة باسم الإدارة النشطة بالاستثناء، بالامتثال للقواعد من أجل تحقيق النتيجة النهائية. يمكن أن تحدث العقوبة إذا لم يلتزم الشخص بالأنظمة (Bass، 2003، Avolio، Jung & Berson). في الواقع، لا يتخذ القائد إجراءات لإبعاد حدوث المشكلة أو عدم التصرف مطلقاً بطريقة ما، تم إعطاء فرص غير كافية للموظفين لشرح الأحداث. تختلف قيادة المعاملات عن القيادة التحولية، وتركز على الحفاظ على الوضع الراهن نون أي تغييرات، حيث يكون أكثر فعالية لاستخدامها في المنظمات التي لديها مشاريع معينة يتعين القيام بها بطريقة معينة (Ogbonna، و Odumeru).

(2013 ، هناك عاملان في قيادة المعاملات وهما المكافأة الطارئة والإدارة بشكل استثنائي (نشط وسلب). أي المكافآت الطارئة التي يتم تقييمها بشكل أكبر يتم تقديمها عندما يفي الموظف بالتوقعات ويصل إلى الأهداف التنظيمية، بينما تركز الإدارة بشكل استثنائي (نشط) على فحص أداء الموظف المستمر وخطه العمل التصحيحية، والإدارة هي الاستثناء (السلب) للقادة الذين ينتظرون حتى تنشأ القضايا (Baah ، 2015) ، كما ورد في (Tung (2016) ، Bass ، 1997) ، للإشارة إلى أن المنافع المتبادلة تعتبر بمثابة الأساس لوجود علاقة بين الموظف وزعيم المعاملات. في الواقع، ترتبط المكافآت والعقوبات ارتباطاً وثيقاً بقائد المعاملات، حيث كان الموظفون المدارون من خلال هذه التدابير في عملية تحقيق الأهداف المحددة في المؤسسة.

يتم تطبيق نظرية Transactional-Transformational of Leadership (باس، 1985 ، 1990 ، بيرنز ، 1978) ، لاختبار ضد الفرضية المبينة. تتضمن هذه النظرية أن قادة المعاملات غالباً ما يركزون على الحصول على نتائج من المرؤوسين بينما يركز قادة التحويل على تحفيز ودعم وتعزيز الجهود تجاه مرؤوسيه (Pastor & Mayo، 2006). تحدث القيادة التحويلية عندما يركز القادة على تلبية الاحتياجات الفردية للمرؤوس، ومشاعره، وكونه مصدر إلهام ولديه أيضاً علاقة كاريزمية تسمح للمرؤوسين باتخاذ القادة كنماذج يحتذى بها. بينما تركز قيادة المعاملات بشكل أكبر على التبادل بين الأعضاء والقادة حيث يستخدم المرؤوسون أدوات لتحقيق أهداف القادة والعكس بالعكس (Pastor & Mayo، 2006). يأتي هذا مرة أخرى مع العوامل المؤثرة مثل التحفيز الفكري، والنظر الفردي، والدافع الملهم للقيادة التحويلية. في حين تركز قيادة المعاملات على عوامل مثل المكافأة الطارئة، إلا أن الإدارة نشطة بشكل استثنائي والإدارة الفعالة بشكل استثنائي.

5.4 التنمية المستدامة

التنمية المستدامة هي المبدأ التنظيمي لتحقيق أهداف التنمية البشرية مع المحافظة في الوقت نفسه على قدرة النظم الطبيعية على توفير الموارد الطبيعية وخدمات النظام الإيكولوجي التي يعتمد عليها الاقتصاد والمجتمع. النتيجة المرجوة هي حالة المجتمع التي تستخدم فيها الظروف المعيشية والموارد لمواصلة تلبية الاحتياجات البشرية دون تفويض سلامة واستقرار النظام الطبيعي. يمكن تعريف التنمية المستدامة بأنها تنمية تلبية احتياجات الحاضر دون المساس بقدرة الأجيال المقبلة (Adams, Jeanrenaud, Bessant, Denyer, & Overy, 2016).

في حين أن المفهوم الحديث للتنمية المستدامة مستمد في معظمه من تقرير برونتلاند لعام 1987 ، إلا أنه متأصل في الأفكار السابقة حول الإدارة المستدامة للغابات والشواغل البيئية في القرن العشرين. مع تطور المفهوم، تحول إلى التركيز أكثر على التنمية الاقتصادية والتنمية الاجتماعية وحماية البيئة للأجيال القادمة. لقد تم اقتراح أن مصطلح "الاستدامة" يجب أن يُنظر إليه باعتباره هدفاً مستهدفاً للإنسانية يتمثل في توازن النظام البيئي البشري، بينما يشير مصطلح "التنمية المستدامة" إلى النهج الشمولي والعمليات الزمنية التي تقودنا إلى نقطة النهاية للاستدامة (Adams et al., 2016). تسعى الاقتصادات الحديثة إلى التوفيق بين التنمية الاقتصادية الطموحة والتزامات الحفاظ على الموارد الطبيعية والنظم الإيكولوجية، حيث ينظر إلى الاثنين على أنهما متضاربان في الطبيعة. فبدلاً من الالتزام بالتغييرات المناخية وغيرها من تدابير الاستدامة كعقار للتنمية الاقتصادية، فإن تحويلها والاستفادة منها إلى فرص السوق سيكون أفضل. تسمى التنمية الاقتصادية الناتجة عن هذه المبادئ والممارسات المنظمة في الاقتصاد "التنمية المستدامة المدارة" (MSD).

إن مفهوم التنمية المستدامة كان ولا يزال خاضعاً للنقد، بما في ذلك مسألة ما الذي يجب إدامته في التنمية المستدامة. لقد قيل أنه لا يوجد شيء مثل الاستخدام المستدام لمورد غير متجدد، لأن أي معدل إيجابي للاستغلال سيؤدي في النهاية إلى استنفاد مخزون الأرض المحدود؛ هذا المنظور يجعل الثورة الصناعية ككل غير مستدامة. وقد قيل أيضاً أن معنى المفهوم قد امتد بشكل انتهازي من "إدارة الحفظ" إلى "التنمية الاقتصادية"، وأن تقرير برونتلاند لم يروج لأي شيء سوى العمل كإستراتيجية معتادة للتنمية في العالم، مع إرفاق مفهوم غامض وغير مهم كمشاعر للعلاقات العامة (Maas, Schaltegger, & Crutzen, 2016).

يمكن تعريف الاستدامة بأنها ممارسة الحفاظ على العمليات العالمية للإنسانية الطبيعية أو البشرية إلى أجل غير مسمى عن طريق استبدال الموارد المستخدمة مع موارد ذات قيمة مساوية أو أكبر دون تدهور أو تعريض النظم الحيوية الطبيعية للخطر. ترتبط التنمية المستدامة معاً بالفترة الاستيعابية للأنظمة الطبيعية مع التحديات الاجتماعية والسياسية والاقتصادية التي تواجهها البشرية. علم الاستدامة هو دراسة مفاهيم التنمية المستدامة وعلوم البيئة. هناك تركيز إضافي على مسؤولية الأجيال الحالية في تجديد موارد الكواكب وصيانتها وتحسينها لاستخدامها من قبل الأجيال القادمة (Quarshie, Salmi, & Leuschner, 2016).

التنمية المستدامة لها جذور في الأفكار حول الإدارة المستدامة للغابات التي تم تطويرها في أوروبا خلال القرنين السابع عشر والثامن عشر. رداً على الوعي المتزايد باستنفاد موارد الأخشاب في إنجلترا، قال جون إيفلين إن "زراعة الأشجار وزراعتها يجب اعتبارها واجباً وطنياً على كل ملاك الأراضي، من أجل وقف الاستغلال المفرط للموارد الطبيعية" في مقاله 1662 سيلفا. في عام 1713 نشر هانز كارل فون كارلوفيتز، كبير مسؤولي التعدين في خدمة الناخب فريدريك أوغستوس الأول من ساكسونيا، Sylvicultura oeconomica، وهو عمل من 400 صفحة عن الغابات. بناءً على أفكار إيفلين والوزير الفرنسي جان بابتيست كولبير، طور فون كارلوفيتز مفهوم إدارة الغابات لتحقيق غلة مستدامة. أثرت أعماله على الآخرين، بما في ذلك ألكساندر فون هنبولت وجورج لودفيج هارتيج، مما أدى في النهاية إلى تطوير علم الغابات. وقد أثر هذا بدوره على أشخاص مثل Gifford Pinchot، أول رئيس لدائرة الغابات الأمريكية، التي كان نهجها في إدارة الغابات مدفوعاً بفكرة الاستخدام الحكيم للموارد، وأدو ليوبولد الذي كان لأخلاقيات الأرض تأثير في تطوير الحركة البيئية في 1960s.

في أعقاب نشر ربيع صامت راشيل كارسون في عام 1962 ، لفتت الحركة البيئية النامية الانتباه إلى العلاقة بين النمو الاقتصادي والتنمية والتدهور البيئي. حدد كينيث إ. بولدينج في مقالته المؤثرة لعام 1966 بعنوان "اقتصاديات سفينة الفضاء القادمة" الحاجة إلى أن يلائم النظام الاقتصادي نفسه بالنظام الإيكولوجي بمجموعه المحدود من الموارد. كان من بين الاستخدامات الأولى للمصطلح "الاستدامة بالمعنى المعاصر" نادي روما في عام 1972 في تقريره الكلاسيكي عن "حدود النمو"، الذي كتبه مجموعة من العلماء بقيادة دينيس دونيلا ميدوز من معهد ماساتشوستس للتكنولوجيا. وكتباً وصفاً لحالة "التوازن العالمي" المرغوب فيه، كتب المؤلفون: "نحن نبحت عن ناتج نموذجي يمثل نظاماً عالمياً مستداماً دون انهيار مفاجئ وغير منضبط وقادر على تلبية المتطلبات المادية الأساسية لجميع أفراد شعبه".

6. منهجية الدراسة

تقنية اختبار الفرضيات هي التقنية التي تم استخدامها في هذه الدراسة، وهذا يعني أن الباحث قام بإنشاء فرضيات تستند إلى أدبيات الأنماط القيادة والتنمية المستدامة وتم اختبارها في مجتمع هذه الدراسة. تحمل هذه الفرضيات إجابات لأسئلة الدراسة. هناك العديد من تم استخدام نهج أسلوب كمي (منهج المسح) لهذه الدراسة. وتستند هذه الدراسة على مستوى نوع البحوث التحليلية. في هذه الطريقة، هناك العديد من الفرضيات التي يتم اختبارها. يتم تطوير تلك الفرضيات استناداً إلى الأسئلة البحثية المبينة على أهداف الدراسة. تم استخدام نهج أخذ العينات العشوائية

الطريقة المناسبة، و هو احد تصاميم احتمالات أخذ العينات، وهي عبارة عن أن كل عنصر واحد في عدد السكان لدية فرصة معروفة و متساوية من اختياره كموضوع.

استخدمت الدراسة الحالية المنهجية الكمية. لهذا ، تم تطبيق مصدر بيانات أولية لهذا البحث. الدراسة النوعية هي عملية استقصائية لفهم مشكلة اجتماعية أو إنسانية، بناءً على صورة معقدة وشاملة، تتكون من كلمات، ويتم الإبلاغ عنها في بيئة طبيعية (Marzanah ، 2009). استخدمت هذه الدراسة أداة الاستبيان ليكون أداة لجمع البيانات. لاستخدام النهج الكمي للدراسة، تم استخدام الاستبيان الاستقصائي كأداة في جمع البيانات من عينات البحث. في هذا الصدد، تم اعتماد بنود الاستبيانات من الدراسات السابقة التي استخدمت نفس المتغيرات التي يستخدمها هذه الدراسة. تم استخدام طريقة أخذ العينات العشوائية في توزيع الاستبيانات على العينات. هذه الطريقة مطلوبة من خلال النهج الكمي للتأكد من أن جميع أفراد المجتمع لديهم فرصة مماثلة ليكونوا عينات.

ركزت هذه الدراسة على العمال والموظفين والمدراء في شركات الصناعات الكيماوية في عمان ليكونوا مجتمع الدراسة. وفقاً للمعلومات الحاصل عليها من أجهزة القطاع الخاص في سلطنة عمان يوجد ثلاث شركات رئيسية فقط التي تعمل في نشاط الصناعات الكيماوية. يتمثل مجتمع الدراسة في 1100 موظف في الشركات الكيماوية في سلطنة عمان. تم تحديد حجم عينة البحث الحالي بناءً على (Krejcie and Morgan، 1970). حجم العينة للبحث الحالي 285 مشارك ومشاركة وهم موظفين في هذه الشركات الثلاث من جميع مستويات الإدارة.

7. النتائج والمناقشة

تقوم هذه الدراسة بعمل العديد من الاختبارات على ثلاثة من المتغيرات المستقلة المتعلقة بالانماط القيادية وأثرها على التنمية المستدامة في قطاع الصناعات الكيماوية في سلطنة عمان، وتم تحديد مجتمع الدراسة من هذه الشركات، ويمكن تصنيف مجتمع الدراسة وفقاً لخمس متغيرات (الجنس، العمر، المستوى التعليمي، المسمى الوظيفي، وسنوات الخبرة). وفيما يلي توضيح لخصائص أفراد الدراسة في ضوء المتغيرات الديموغرافية. الجول (1) يوضح توزيع أفراد عينة الدراسة حسب متغيرات الدراسة.

7.1 الجنس:

الجدول رقم (1) يبين أن مانسبته 67.8% لعدد (193) مستجيب من الذكور بينما عدد الاناث تقريباً 92 أي بنسبة 32.2%. يدل ذلك على نسبة الذكور تمثل نسبة أكبر مقارنة بعدد الاناث ويعزو الباحث ذلك الى ان طبيعة و ثقافة المجتمعات العربية من حيث العمل والوظيفة حيث يقتصر على الذكور أكثر من الاناث.

7.2 العمر:

يبين الجدول رقم (1) ان اغلبية المستجيبين اعمارهم من 31 إلى 40 سنة أي مانسبته 40.6% لعدد 115 مستجيب، بينما 23.5% لعدد 66 من المستجيبين اعمارهم تتراوح بين 41 الى 50 سنة ، بينما كان العدد الاصغر منهم 49 مستجيب بنسبته 16.5% اعمارهم أكثر من 50 ، كذلك نسبة تمثل 16.4% لعدد 55 مستجيب اعمارهم بين 20 الى 30 سنة.

7.3 المستوى التعليمي:

الجدول رقم (1) يستعرض توزيع أفراد العينة حسب المؤهلات العلمية، حيث يبين أكثر نسبة 35.6% ، بعدد (101) مستجيب من شركات الصناعات الكيماوية في سلطنة عمان يحملون شهادات البكالوريوس، يلي ذلك 83 مستجيب من إجمالي افراد العينة 285 أي بنسبة 29.4% يحملون شهادة الماجستير، بينما الذين يحملون شهادة الدكتوراة والدبلوم العالي يمثلون 12.5% و 15% لعدد 83 و 42 على التوالي لعدد، واخيراً أقل نسبة 7.5% لعدد 21 يحملون شهادة الدبلوم المتوسط.

7.4 المسمى الوظيفي:

الجدول رقم (1) يستعرض توزيع أفراد العينة حسب المسمى الوظيفي، حيث تمثل نسبة الموظفين اعلى نسبة 37.2% تقريباً لعدد 106 مستجيب من إجمالي افراد العينة 285 من الموظفين في قطاع الصناعات الكيماوية في سلطنة عمان، بينما تمثل عدد 101 تحتى مسمى أخرى بنسبة 35.9% . ومن خلال النتائج وجد 14.4% لعدد 41 من إجمالي 285 مستجيب يمثلون مدراء في الإدارات الوسطى، إضافة إلى مدراء الإدارات العليا الذين يمثلون 12.5% لعدد 36 من الموظفين في قطاع الصناعات الكيماوية في سلطنة عمان.

7.5 سنوات الخبرة:

يتضح من خلال الجدول رقم (1) ان اكثر نسبة 29.7% لعدد 84 من أفراد عينة الدراسة يمتلكون خبرة عملية من 6 إلى 10 سنوات وكذلك نسبة 23.8% لعدد 67 يمتلكون خبرة ما بين 11 إلى 15 سنة، بينما عدد 57 مستجيب أي ما بنسبته 20% يمتلكون خبرة عملية من سنة إلى 5 سنوات، إضافة إلى عدد 39 بنسبة 13.4% يمتلكون خبرة عملية ما بين 16 إلى 20 سنة، وأقل نسبة 12.8% لعدد 38 من إجمالي افراد عينة الدراسة 285 مستجيب يمتلكون خبرة عملية أكثر من 20 سنة.

جدول 5: الخصائص السكانية للعينة

الخصائص الديموغرافية	عدد ونسبة الاستجابة	الخصائص الديموغرافية	عدد ونسبة الاستجابة
العمر		المستوى التعليمي	
55, 19.4%		دبلوم متوسط	21, 7.5%
		من 20-30 سنة	

40.6% ,115	من 31-40 سنة	35.6% ,101	بكلوريوس
23.5% ,66	من 41-50 سنة	15% ,42	دبلوم عالي
16.5% ,49	أكثر من 50 سنة	29.4% ,83	ماجستير
		.5%12 ,38	دكتوراة
الجنس			
67.8% ,193	ذكر		
32.2% ,92	انثى		

الوظيفة	
12.5% ,36	الإدارة العليا
14.4% ,41	الإدارة الوسطى
%37.2 ,106	موظف
.9%35 ,102	أخرى

سنوات الخبرة	
20% ,57	1-5 سنوات
29.7% ,84	من 6-10 سنوات
23.8% 67	من 11-15 سنة
13.4% ,39	من 16-20 سنة
12.8% ,38	أكثر من 20 سنة

7.6 اختبار ألفا كرونباخ Alpha Gronbach

كما تم اختبار الموثوقية Cronbach's Alpha لجميع متغيرات الدراسة وكانت النتائج لجميع المتغيرات أكبر من 0.60 وهي مقبولة وجيدة، كما كان معامل كرونباخ ألفا أكبر من 0.60 ومحسورة بين 0.941 و 0.832 للتنمية المستدامة و القيادة التبادلية. جدول رقم 2 يوضح نتائج اختبار الموثوقية ومعامل Cronbach's Alpha لجميع متغيرات.

جدول 6: اختبار الموثوقية

العوامل	عدد الفقرات	قيمة معامل الفاكر ونباخ
القيادة التحويلية	7	0.891
القيادة التبادلية	7	0.832
القيادة الرسمية	7	0.865
التنمية المستدامة	5	0.941

7.7 اختبار الارتباط الخطي المتعدد Multicollinearity Test

تم فحص الارتباط الخطي المتعدد من خلال مقياس Collinearity Diagnostics وذلك باحتساب معامل Tolerance لكل متغير من المتغيرات المستقلة، من ثم يتم إيجاد معامل Variance Inflation Factor (VIF) حيث يعد هذا النموذج مقياساً لتأثير الارتباط بين المتغيرات المستقلة ومن الجدول رقم (3) يلاحظ أن معامل VIF لجميع المتغيرات لم يتجاوز (5) ومحسورة بين 0.4762 و 0.0023 ، وكذلك فترة السماح Tolerance أكبر من 0.10 ومحسورة بين 0.390 و 0.578 ، (Hair et al., 2006; Sekaran, 2003) لذلك يمكن القول بأن نموذج الدراسة لا يعاني من مشكلة

التداخل الخطي، فالارتباط بين المتغيرات غير ذي دلالة إحصائية ومنخفض جداً، وهذا يدل على قوة نموذج الدراسة في تفسير الأثر على المتغير التابع وتحديده.

الجدول 3 اختبار التداخل الخطي والارتباط الذاتي لنموذج المتغيرات المستقلة وأثرها على التنمية المستدامة

التداخل الخطي			
المتغير	البعد	Tolerance	VIF
الأنماط القيادية	القيادة التحويلية	0.578	3.002
	القيادة التبادلية	0.298	2.476
	القيادة الرسمية	0.390	2.902

7.8 نتائج التشبعات العاملية للفقرات (Factor loading)

الجدول رقم (4) يبين كل التشبعات لجميع فقرات المحاور والمتغيرات أكثر من (0.50) ومحصورة بين (0.512 و 0.899) وهي قيم مقبولة في هذه الدراسة حيث إن حجم العينة تساوي 285.

جدول (4): التشبعات العاملية للفقرات

المتغيرات	التحميل	كورنياخ الفا	معامل الثبات	معامل التباين
	Loading	Cronbach Alpha	المركب	المشترك
			C.R	AVE
المتغير التابع: التنمية المستدامة				
SD1	0.512	0.941	0.937	0.600
SD6	0.840			
SD5	0.801			
SD8	0.768			
SD4	0.836			
SD7	0.819			
SD3	0.804			
SD9	0.767			
SD11	0.689			
SD2	0.851			
المتغيرات المستقلة: الأنماط القيادية				
القيادة التحويلية				
TRF2	0.862	0.891	0.934	0.739
TRF3	0.881			
TRF4	0.899			
TRF1	0.802			
TRF5	0.851			
القيادة التبادلية				
TRN5	0.726			
TRN4	0.724			

7.9 نتائج كمو (KMO)

أما من ناحية الجودة الكلية للاختبار ومدى ملائمة العينة به فقد كشفت نتيجة اختبار قيصر (كايزر ماير أولكن واختبار باتليت) الجودة العالية لهذا الاختبار. يعتبر مقياس كايزر-ماير-اولكين (واختصارا ، مقياس كمو) واختبار بارتلليت معايير أساسية لاختبار ملائمة العينة للتحليل العاملي. اختبار بارتلليت يجب أن يكون ذو دلالة إحصائية أقل من (0.05)، وكانت متوسط نتيجة KMO لجميع المتغيرات تشير الى جودة جيدة فوصلت إلى 0.958 و نتيجة Bartlett بالنسبة الفائية = 0.000 ودرجة الحرية 595 والنتيجة كما هو واضح من النموذج التالي:

جدول رقم (5) كمو واختبار باتليت

مقياس أخذ العينات الملائمة لكايزر ماير أولكين		KMO	
0.958			
10334.834		اختبار كروية لباتليت	
595		Df	Bartlett
0.000		Sig.	

7.10 المتوسطات لحسابية والانحرافات المعيارية لمتغيرات ومحاور الدراسة

يوضح الجدول 6 المتوسطات الحسابية والانحرافات المعيارية لمتغيرات الدراسة: المتغير التابع التنمية المستدامة، المتغير المستقل الأنماط القيادية (القيادة التحولية و القيادة التبادلية و القيادة الرسمية).

فقد حصل أبعاد المتغير المستقل الأنماط القيادية (القيادة التحولية و القيادة التبادلية و القيادة الرسمية) على متوسطات حسابية متقاربة وجيده على التوالي 3.235 و 3.641 و 3.216 من إجمالي 5 ونسبة موافقة 64 % و 73 % و 64 % وكانت القيم أكثر من الوسط الافتراضي 3 و المتوسط العام لمتغير الأنماط القيادية 3.364 ونسبة موافقة 67 % وانحراف معياري 0.74656. ويتضح من النتائج أن هناك إجماع على موافقة أفراد عينة الدراسة على أهمية القيادة للعاملين الذي بدور يؤدي إلى التنمية المستدامة في الشركات الكيميائية في سلطنة عمان. وأظهرت نتائج الدراسة ان المتغير التابع التنمية المستدامة حصل على متوسط حسابي جيد بقيمة 3.493 ونسبة موافقة 70% وهي نسبة جيدة دلالة على أهمية التنمية المستدامة للعاملين بالشركات الكيميائية في سلطنة عمان، وأظهرت نتائج الدراسة ان الانحرافات المعيارية لجميع متغيرات الدراسة محصورة بين 0.57424 و 0.91651 وهي قيم منخفضة تدل على تقارب القيم عن متوسطها الحسابي لجميع متغيرات الدراسة. الجدول رقم 6 يبين المتوسطات الحسابية و الانحراف المعياري لمحور وأبعاد الدراسة.

الجدول رقم 6 المتوسطات الحسابية والانحراف المعياري لمتغيرات الدراسة

الانحراف المعياري	المتوسط الحسابي	البعد	المتغير
.78704	3.493		لتنمية المستدامة
.74656	3.364	3.235	القيادة التحويلية
.91651		3.641	القيادة التبادلية
.57424		3.216	القيادة الرسمية

7.11 تحليل الارتباط

يستخدم تحليل الارتباط لإيجاد العلاقة بين المتغير التابع والمتغيرات المستقلة، والهدف من ايجاد هذه العلاقة هو معرفة مدى ارتباط المتغيرات المستقلة بالمتغير التابع، حيث ان وجود علاقة مع المتغير التابع كانت عكسية او طردية وذات اهمية تؤكد مدى ارتباط هذا المتغير مع المتغير التابع وعليه فان احداث اي تغيير في المتغير المستقل سوف ينعكس على المتغير التابع بالزيادة او النقصان. اوضحت النتائج المستسقاة من الدراسة ان هناك علاقة طردية وهامة بين القيادة التحويلية و التنمية المستدامة في الشركات الكيميائية في سلطنة عمان. مع $R = 0.309$ وأهمية تساوي 0.000. كما وجدت ايضا علاقة طردية وهامة بين القيادة التبادلية و التنمية المستدامة في الشركات الكيميائية في سلطنة عمان. مع $R = 0.580$ وأهمية تساوي 0.000. وأخيرا وجدت علاقة ضعيفة بين القيادة الرسمية و التنمية المستدامة في الشركات الكيميائية في سلطنة عمان. يوضح الجدول التالي رقم 7 هذه النتائج.

جدول رقم 7 تحليل الارتباط لجميع متغيرات الدراسة

المتغيرات	القيادة التحويلية	القيادة التبادلية	القيادة الرسمية	لتنمية المستدامة
القيادة التحويلية	1			
القيادة التبادلية	.430**	1		
القيادة الرسمية	.815**	.396**	1	
لتنمية المستدامة	.309**	.580**	.249*	1

** . Correlation is significant at the 0.01 level (2-tailed).

* . Correlation is significant at the 0.05 level (2-tailed).

7.12 تحليل الانحدار لاختبار فرضيات الدراسة

بالرجوع إلى الشكل رقم 7 لتحليل المسار واختبار مربع الارتباط المتعدد (الانحدار) R^2 الذي يتضمن النتائج الخاصة بمعامل التحديد coefficient of determination الذي هو أهم مؤشر لبيان مقدار تأثير الأنماط القيادية على التنمية المستدامة. كما يوضح الجدول 7 ان قيمة R^2 ويعتبر مقياساً لجودة توفيق النموذج و نجد أنه أي معامل التحديد R^2 مساوياً 62% هذا معناه مجموعة المتغيرات المستقلة ممثلة الانماط القيادية تفسر وتشرح من التغييرات (أي التباينات أو الانحرافات الكلية) التي تحدث في قيم المتغير التابع التنمية المستدامة بقيمة 0.62 أي ان المتغيرات المستقلة فسرت وشرحت مانسبته 62% من التغييرات (أي التباينات أو الانحرافات الكلية) التي تحدث في قيم المتغير التابع التنمية المستدامة. وهي علاقات جيدة وقريبة من 100% و الباقي يرجع إلى عوامل أخرى منها الخطأ العشوائي أو أن هناك متغيرات لم تتضمن في النموذج و على العموم كلما اقتربت قيمة R^2 من 100% يدل ذلك على جودة النموذج.

كما ان اختبار الانحدار اظهر نتائج مساهمة المتغيرات المستقلة على المتغير التابع، فقد اظهرت اثنين من المتغيرات المستقلة (القيادة التحويلية و القيادة التبادلية) مساهمة ذات اهمية نسبية في احداث تأثير مباشر على المتغير التابع الخاص بالدراسة والمتمثل في التنمية المستدامة في الشركات الكيمايية في سلطنة عمان، بينما اتضح ان المتغير المستقل الثالث (القيادة الرسمية) لا يساهم ولا ياتر على التنمية المستدامة في الشركات الكيمايية في سلطنة عمان. يظهر الجدول رقم 7 ان القيادة التحويلية يمثل المتغير الاكثر تأثيرا في التنمية المستدامة، حيث ان كل وحدة سوف يقابلها 0.531 من جانب التنمية المستدامة، كما يظهر الجدول ان القيادة التبادلية ترتبط مع التنمية المستدامة بعلاقة مباشرة وذات اهمية نسبية، الذي يوضح ان زيادة القيادة التبادلية تقود الى رفع التنمية المستدامة، حيث ان كل وحدة سوف يقابلها 0.017 من جانب التنمية المستدامة.

الجدول رقم 8: معامل الانحدار R2 و معامل الانحدار المعدل R Square Adjusted

Sig.	t	Standardized Coefficients		Unstandardized Coefficients		Model	
		Beta	Std. Error	B			
.000	6.332		.512	3.240		(Constant)	
.000	3.127	.596	.170	.531		1 القيادة التحويلية	
.007	4.130	.516	.134	.017		القيادة التبادلية	
.087	3.887	.728	.178	.210		القيادة الرسمية	
						62 %	أر سكوير

a. Dependent Variable: التنمية المستدامة

8. المناقشة

لأغراض التحليل واختبار الفرضيات التي حددتها الدراسة، فقد تم اعتماد بعض المؤشرات الإحصائية باستخدام الحزمة الإحصائية للعلوم الاجتماعية (SPSS) حيث تم استخدام التكرارات والنسب المئوية لبيان خصائص مفردات عينة الدراسة، والوسط الحسابي لمعرفة مستوى إجابة أفراد العينة على فقرات متغيرات الدراسة. والانحراف المعياري لمعرفة مدى تركيز وتشتت الإجابات عن وسطها الحسابي.

واستخدم الباحث التحليل العاملي الاستكشافي لحصر العوامل على التباينات المشتركة بين المتغيرات فقط. واستخدم الباحث اختبار KMO & Bartlett من أجل التحقق من الجودة الكلية للاستبانة. وكذلك تم استخدام برنامج معادلة النمذجة البنائية AMOS لتأكيد التحليل العاملي للعوامل والفقرات، (Confirmatory Factor Analysis (CFA) وما مدي مطابقتها مع التحليل العاملي الاستكشافي، وكذلك اختبار الفرضيات، وقد أظهرت نتائج تحليل المسار وجود علاقة مباشرة ارتباطية موجبة وقوية ومقبولة بين كلا من القيادة التحويلية و القيادة التبادلية مع التنمية المستدامة في الشركات الكيمايية في سلطنة عمان. هذه النتائج أنتت موازية و متناسقة مع النتائج التي اثبتت في الدراسات السابقة.

أكدت دراسة (السيادة 2015، et al.) التي كانت بعنوان القيادة التحويلية وأثرها في فاعلية سلوك العاملين في المستشفيات الأردنية الحكومية والخاصة. هدفت هذه الدراسة إلى تحديد مدى اعتماد أسلوب القيادة التحويلية في المستشفيات العامة والخاصة في الأردن، وفعالية سلوك موظفيها. كما تهدف الدراسة إلى دراسة تأثير متغيرات القيادة التحويلية (النزف المثالي، والدافع الملهم، والتحفيز الفكري، والاعتبار الفردي) على فعالية سلوك الموظفين في المستشفيات الأردنية العامة والخاصة. غطى سكان الدراسة جميع المستشفيات العامة والخاصة الأردنية، حيث تم توزيع عينة من (249) مسحا على جميع مستويات الإدارة العليا والمتوسطة (مدير عام، مدير إدارة أو ما يعادلها، رئيس القسم أو ما يعادله)، وكان عدد الاستطلاعات التي تم إرجاعها (188) والتي نظرت للتحليل الإحصائي، تغطي (75 %) معدل الاستجابة. أظهرت النتائج أن تبني أسلوب القيادة التحويلية في المستشفيات العامة والخاصة في الأردن مرتفع، كما أن فعالية سلوك موظفيها مرتفعة أيضاً. بالإضافة إلى ذلك، وجدت الدراسة أن جميع متغيرات القيادة التحويلية

أثرت على فعالية سلوك الموظفين ، وكان متغير التحفيز الفكري هو المتغير الأكثر تأثيراً. ووجدت الدراسة أيضاً أن درجة تبني القيادة التحويلية كانت أعلى في المستشفيات الخاصة مقارنةً بالمستشفيات العامة. أيضاً ، لم يكن هناك دلالة إحصائية في تبني نمط القيادة التحويلية في المستشفيات الأردنية العامة والخاصة بسبب المتغيرات الديموغرافية (الجنس والعمر والمؤهل والمستوى الإداري) ؛ في حين وجدت الدراسة أهمية إحصائية في تبني نمط القيادة التحويلية في المستشفيات الأردنية العامة والخاصة بسبب متغير التجربة.

كما أظهرت دراسة (Slimane, 2012) التي كانت بعنوان الدور والعلاقة بين القيادة والتنمية المستدامة لإطلاق البعد الاجتماعي والإنساني والثقافي. إذا كانت التنمية المستدامة تعني تأمين الأجيال القادمة على التقدم والتطور. العلاقة بين القيادة والتنمية المستدامة مهمة للغاية ، لأنه لا توجد تنمية بدون قيادة خاصة في البعد الاجتماعي والإنساني والثقافي. يهدف هذا الاقتراح أو الورقة إلى توضيح دور القيادة في التنمية المستدامة. ولكن كيف يمكن للقيادات أن تلعب هذا الدور في المجتمع الحديث.

أيضاً أجريت دراسة (Stefane; Said; and Rafik) 2019 بعنوان تأثير أسلوب القيادة على الابتكار المستدام. في بيئة سريعة التغير ، يعد الابتكار أمراً ضرورياً في الحفاظ على بقاء المؤسسات العامة والخاصة على المدى الطويل. استخدمت الورقة التالية البحث الكمي بهدف فهم تأثير متغيرات مؤشر الابتكار العالمي على الابتكار في 64 دولة. تم استخدام تحليل الانحدار الفردي لإيجاد الارتباط بين مؤشر الابتكار العالمي (II) والمؤشرات الأخرى مثل مؤشر الفعالية الحكومية (GEI) ، مؤشر عم المساواة بين الجنسين (Bulgakow, Tokmakov, Otto, & Langosch) ، مؤشر التنوع الثقافي (CDI) من بين أمور أخرى لفهم كيفية المتغيرات المذكورة أعلاه تتأثر وتؤثر على الابتكار في البلدان التي شملتها الدراسة. تقدم دراستنا شرحاً موجزاً للعلاقة المعقدة بين القيادة التحويلية وتأثيراتها على الثقافة التنظيمية المبتكرة والحديثة ، حيث تتدفق الهرم الهرمي للقطاعات العام والخاص. سوف يفيد هذا البحث مجتمع الأعمال والحكومات وأصحاب المصلحة المختلفين في فهم المتغيرات وأنواع القيادة الأكثر فاعلية وارتباطاً بالابتكار.

دراسة (Alex, UKVian, and Heather) 2015 بعنوان أسلوب القيادة للمهنيين الاستدامة في صناعة البناء في المملكة المتحدة. القيادة هي عمل نجاح كبير في تعزيز ممارسات الاستدامة في صناعة البناء والتشييد. الاستدامة هي جزء لا يتجزأ من صناعة البناء والتأثير على جميع جوانب عمليات البناء التجارية. الغرض من هذه الورقة هو التحقق مما إذا كان هناك أي نمط قيادة معين مرتبط بالقيادة داخل المنظمات داخل منظمات البناء في المملكة المتحدة المكلفة بالترويج لممارسات الاستدامة. تبحث الورقة بالتالي في أسلوب القيادة الفعال لأخصائيي الاستدامة المسؤولين عن تطوير استراتيجيات البناء المستدامة. تم جمع البيانات النوعية من خلال مقابلات شبه منظمة مع 15 من القادة ، تلتهها دراسة استقصائية على مستوى الصناعة تضم 200 من القادة داخل المنظمات في منظمات المقاولين والاستشاريين في صناعة البناء في المملكة المتحدة. أظهرت النتائج أنه على الرغم من عدم وجود أفضل أسلوب قيادة لجميع المواقف ، إلا أن معظم القادة المكلفين بدور تعزيز البناء المستدام هم إستراتيجيون في أسلوبهم أو سلوكهم. على الرغم من أن القيادة والاستدامة قد تمت تغطيتهما على نطاق واسع كقضايا منفصلة ، إلا أنه لم يتم إجراء سوى القليل من البحث الدقيق حول الصلة بين القيادة والاستدامة في أبحاث إدارة البناء. يمكن أن توجه النتائج القادة التنظيميين الذين يتحملون مسؤولية تعزيز ممارسات الاستدامة.

9. الخلاصة

تم تطوير وإنشاء هذه الدراسة لغرض معرفة مدى تأثير الأنماط القيادية على التنمية المستدامة في قطاع الصناعات الكيماوية بسلطنة عمان. تمحورت مشكلة الدراسة في أنه بالرغم من كل محاولات سلطنة عمان و العملين في السلطنة في مجال الشركات الصناعية على تحقيق التنمية المستدامة، إلا أن السلطنة لم تستطع تحقيق التنمية المستدامة على اتشكالها. تكمن مشكلة الدراسة الحالية في إيجاد ومعرفة ماقد يحقق التنمية المستدامة في السلطنة في المجال الصناعي. عليه، يسعى الباحث من خلال الدراسة الحالية الى معرفة مدى تأثير الانماط القيادية على التنمية المستدامة..

بناء على مشكلة الدراسة، قامت الدراسة الحالية بإقتراح اطار بحثي ليتم دراسته، احتوى الاطار البحثي على ثلاثة ابعاد مستقلة تمثل الأنماط القيادية و هي (القيادة التحويلية و القيادة التبادلية و القيادة الرسمية). تمت دراسة مدى تأثير هذه الابعاد على التنمية المستدامة في قطاع الصناعات الكيماوية بسلطنة عمان. المنهج المستخدم في الدراسة هو المنهج الوصفي التحليلي حيث تم جمع البيانات من المستجيبين على طبيعة العلاقة بين الأنماط القيادية و التنمية المستدامة. حدد مجتمع الدراسة بجميع العاملين والموظفين في ثلاث شركات رئيسية و هي شركة الخليج الدولية للكيمويات و شركة المنظفات الوطنية و شركة الكلور العماني و حددت عينة الدراسة من جميع الموظفين في هذه الشركات. كما كانت العينة المشاركة في الدراسة عبارة عن 285 استبانة صالحة للتحليل الإحصائي، حيث تم إختيار عينة الدراسة بطريقة العينة العشوائية الطبيعية. من خلال اختبار الفرضيات، فقد أظهرت نتائج تحليل المسار وجود علاقة مباشرة ارتباطية موجبة وقوية و مقبولة بين القيادة التحويلية و التنمية المستدامة و بين القيادة التبادلية و التنمية المستدامة.

المراجع العربية

- الالكترونية، ا.ا.ل. (2019). مؤشرات التنمية المستدامة from [/https://omanportal.gov.om/wps](https://omanportal.gov.om/wps)
- المليدة، جميل، ن. ح.، مساعده، راند، الزعبي، & محمد، ز. (2015). القيادة التحويلية وأثرها في فاعلية سلوك العاملين في المستشفيات الأردنية الحكومية والخاصة. Jordan Journal of Administration, 11 (1 of Business).
- ليدية، أ.أ. (2016). فعالية القيادة الإدارية في عصر العولمة.
- محمد، ع.إ.، & أبوسن، أ.إ. (2009). القيادة الإدارية وأثرها في الأداء. جامعة السودان للعلوم والتكنولوجيا.

المراجع الاجنبية

- Avolio, B. J., Bass, B. M & Jung, D. I. (1999). ' (Re-Examining The Components of Transformational and Transactional Leadership Using the Multifactor Leadership'. Journal of Occupational and Organizational Psychology, 72 (4.462-441).
- Birasnav, M. (2014). ' Relationship Between Transformational Leadership Behaviors and Manufacturing Strategy'. International Journal of Organizational Analysis, 22.223-205. (2)
- Dartey-Baah, K. (2015). ' Resilient Leadership: A Transformational-Transactional Leadership Mix'. Journal of Global Responsibility, 6.(1) .112-99
- Galpin, T. J. (2017). Creating a culture of sustainability in entrepreneurial enterprises Entrepreneurship, Innovation and Sustainability (pp. 78-97):(Routledge.
- Harrower, M. J & Nathan, S. (2018). Ancient water management in southern Arabia :Creativity, resilience and sustainability in Yemen and Oman Water and Society from Ancient Times to the Present (pp. 201-218) : Routledge.
- Ivey, G. W & Kline, T. J. (2010). ' Transformational and active transactional leadership in the Canadian military'. Leadership & Organization Development Journal, 31 (3), 246-262.
- Maksood, F. Z & Achuthan, G. (2017). Sustainability in Oman: Energy Consumption Forecasting using R. Indian Journal of Science and Technology, 10 (10.14-1).
- Nasrollahi, Z., Hashemi, M.-s., Bameri, S & Taghvaei, V. M. (2018). Environmental pollution, economic growth, population, industrialization, and technology in weak and strong sustainability: using STIRPAT model. Environment, Development and Sustainability, 1-18.
- Nguyen, L. D., Tanner, T & Pham, L. N. (2019). Cross-culture management: an empirical examination on task and relationship orientations of Japanese and Omani working adults. International Journal of Human Resources Development and Management, 19 (1), 92-103.
- Odumeru, J. A & Ogbonna, I. G. (2013). 'Transformational vs. transactional leadership theories: Evidence in literature'. International Review of Management and Business Research, 2 (2), 355.
- Shamsuzzoha, A., Al-Kindi, M & Summad, E. Measurement of Innovation Performance in Selected industries in Sultanate of Oman.
- Smith, P. A. C & Sharicz, C. (2011). The shift needed for sustainability. The Learning Organization, 18 (1), 73-86.
- Yaghoubipoor, A., Puay Tee, O & Musa Ahmed, E. (2013). ' Impact of the relationship between transformational and traditional leadership styles on Iran's automobile industry job satisfaction'. World Journal of Entrepreneurship, Management and Sustainable Development, 9 (1), 14-27.

القيادة الملهمة وأثرها على صناعة التميز الوظيفي في القطاع الحكومي بدولة الإمارات العربية المتحدة – جوائز التميز الوظيفي أنموذجاً

Mona Jawad Salman

منى جواد سلمان
إدارة الموارد البشرية-كلية القيادة والإدارة
جامعة العلوم الإسلامية الماليزية

محمد بطور

Mohamed Battour

Faculty Of Leadership and Management,
University Science Islamic Malaysian (USIM), Malaysian and Faculty of commerce Tanta
University, Egypt.

الملخص

تفرد الدراسة كونها أول دراسة كمية تطبق على الفائزين في جوائز التميز الوظيفي في دولة الإمارات العربية المتحدة في ثمانية جوائز معتمدة في الدولة خلال خمس وعشرون عاماً. تهدف الدراسة إيجاد أثر القيادة الملهمة على صناعة التميز الوظيفي في القطاع الحكومي بدولة الإمارات. ولتحقيق أهداف الدراسة استخدمت الباحثة المنهج الكمي والوصفي التحليلي، وصممت الاستبيان كأداة للدراسة. تم صياغة الاستبيان في (4) محاور و(10) فقرات و(50) عبارة، مصدرها: أنموذج القيادة الحكومية لدولة الإمارات، ومعايير التميز الوظيفي المعتمدة في منظومة التميز الحكومي في الدولة والمتوافقة مع معايير المؤسسة الأوروبية للجودة الشاملة، ويُعدي الدوافع الداخلية والخارجية في نظرية دافعية الإنجاز وتحقيق الذات لمواري وماكيلاند، ومعايير قياس أدوار جوائز التميز الوظيفي ومدى ملائمة معايير التنافس. يتكون مجتمع الدراسة من كافة الموظفين المتميزين الحاصلين على جوائز التميز الوظيفي في دولة الإمارات العربية المتحدة، وعددهم (1063) موظفاً، وتشكل عينة الدراسة نسبة (35%) من مجتمع الدراسة (372) تم اختيارهم بالطريقة الطبقية، مراعاة للتنوع في حجم العينة من حيث عدد الموظفين الفائزين بجوائز التميز الوظيفي في مؤسسات القطاع الحكومي في دولة الإمارات. وتم معالجة البيانات من خلال برنامجي (AMOS22) وبرنامج الحزمة الإحصائية (SPSS). ومن المتوقع أن تظهر نتائج الدراسة أثر القيادة الملهمة على صناعة التميز الوظيفي في مؤسسات القطاع الحكومي بدولة الإمارات العربية المتحدة وفق أنموذج الدراسة الذي يتكون من المتغيرات المستقلة: القيادة الملهمة، وممارسات الموظف المتميز، والمتغيرات المؤثرة: دافعية الإنجاز وتحقيق الذات، وجوائز التميز الوظيفي. وبناءً على تحليل نتائج الدراسة ستقوم الباحثة برصد التوصيات والمقترحات.

الكلمات المفتاحية: القيادة- القيادة الملهمة- التميز- التميز الوظيفي- صناعة التميز- الدوافع الذاتية- دافعية الإنجاز- جوائز التميز الوظيفي.

المقدمة

حظي مفهوم الموارد البشرية باهتمام الباحثين وخبراء الاقتصاد في العلوم الإدارية في الفكر الحديث مع تطور نظرية الإدارة العلمية لفرديريك تايلور (1856-1915)، الذي وجه الاهتمام نحو ثورة فكرية جديدة وفلسفة إدارية تنادي بالتغيير الشامل في مفهوم الإدارة باعتبارها علاقات تقاعلية مترابطة ومتداخلة بين العاملين والمؤسسة تعتمد في نجاحها على العنصر البشري. وقد ربطت التaylorية بكفاءة الأداء ورفع الإنتاجية المؤسسة مقابل المغريات والمحفزات مما فجرت أسلوب إداري جديد في التعامل التحفيزي مع العاملين في المؤسسات (السكران، 2019؛ كنعان، 1995). أفرزت هذه الأفكار سلسلة من التطورات في المجال الإداري، وحفزت الباحثين والخبراء وعلماء الاقتصاد للمزيد من الدراسات حول تأثير تقدير وتحفيز الموارد البشرية على رفع الإنتاجية وتحقيق التميز الوظيفي والمؤسسي، ويتبع ويليام إدواردز ديمنج (1900-1993) من أبرز أنصار هذا الفكر الحديث، حيث أدرك ديمنج أن الموظفين هم وحدهم الذين يتحكمون بالفعل في عملية الإنتاج ونجاح المؤسسة، ويجب أن يتصدروا محور اهتمام القيادات المؤسسية (سلمان م، 2018). من ذلك المبدأ بدأ اهتمام الباحثين بمفاهيم القيادة وسماتها وأنماطها، نظراً للتأثير البالغ لسلوك القيادات وممارساتهم مع العاملين باستثارة قدراتهم وتميزهم في الأداء الوظيفي وصولاً إلى التميز المؤسسي. إذ يتوقف تقدم المنظمات أو فشلها على مدى النجاح الذي يحققه القائد في ممارساته مع الموارد البشرية واحترام آرائهم ورفع دوافعهم نحو العمل وحشد الجهود نحو الأداء والإنجاز، ومدى انقلبه لمختلف الأنماط القيادية عند التعامل مع المرؤوسين في مختلف المواقف والظروف وبمهارة وفعالية. (ماكجراث وبايتس، 2019؛ كوزيس و بوسنر، 2018). إن من أبرز الأنماط القيادية التي أفرزتها الإدارة الحديثة، والتي يمكن اعتبارها العلامة الفارقة في سلوكيات القيادات هي نمط القيادة الملهمة. حيث تمثل مزيج من الأنماط القيادية في نمط واحد، ويتميز فيه القائد بقدرته على إلهام المرؤوسين نحو تحقيق رؤية المنظمة باستثارة مهاراتهم وقدراتهم. وقد تعددت تعريفات الباحثين والعلماء للقيادة الملهمة، وتتمحور أغلبها في السلوك الاستثنائي للقائد في فهم وتقدير الأتباع وامتلاك التأثير الذاتي لتحويل المرؤوسين إلى أتباع راغبين في قيادته بطواعية، بتعزيز مواهبهم وقدراتهم الكامنة والظاهرة وتحفيزهم على النجاح الشخصي والمهني (سرحان، 2018؛ بيندلبيتون و آدرابن، 2019).

جاءت هذه الدراسة لتسلط الضوء على التميز الوظيفي في القطاع الحكومي بدولة الإمارات العربية المتحدة، وأثر ممارسات القائد الملهم على فئة الموظفين المتميزين، ودفعهم للمشاركة في جوائز التميز الوظيفي ونيل أشكال التقدير والتعزيز من الجهات المعتمدة رسمياً في الدولة. كما تبحث الدراسة في تأثير كل من ممارسات الموظف المتميز ودوافعه الذاتية وأدوار جوائز التميز الوظيفي في حصول الموظفين على جوائز التميز. حيث لم ترد الأبحاث والدراسات الكافية للبحث عن الأسباب المباشرة لفوز الموظفين المتميزين وحصولهم على جوائز التميز في الدولة. ويتوقع أن تظهر نتائج الدراسة عن أهم العوامل المؤثرة في تميز الموظفين في القطاع الحكومي بدولة الإمارات العربية المتحدة.

1 - المحور الأول: الإطار العام للدراسة

1.1 خلفية الدراسة

يشهد العالم تحولاً جذرياً تجاه الاهتمام بمواهب وقدرات الموارد البشرية، جنباً إلى جنب الاهتمام بالتكنولوجيا والتقنية الحديثة لتطوير مجالات الحياة، حيث يمثل العنصر البشري ركيزة أساسية للنهوض والتقدم والنمو الاقتصادي لأي دولة، والمحرك الأول والأقوى لتطوير التكنولوجيا في خدمة المجتمع. إن الاهتمام بالتطور التكنولوجي أصبح يوازي الاهتمام بالعنصر البشري، وعكسهما صحيح، فالتكنولوجيا والعنصر البشري وجهتان لعملة التقدم. وقد وصفها شواب؛ الرئيس التنفيذي للمنتدى الاقتصادي العالمي، في كتابه الثورة الصناعية الرابعة، بـ "أرض المعركة" ما بين التكنولوجيا والإنسان، فيقدر ما تغزو التكنولوجيا العالم بوتيرة سريعة؛ تُقدم قدرات فذة تواكب ذلك التقدم (شواب، 2016، الصفحات 6،7). إن الاهتمام العالمي بتتمية قدرات الموارد البشرية وتوجيه طاقاتها نحو الإبداع والابتكار والأداء المتميز المتقن؛ وجه الحكومات المتقدمة إلى وضع استراتيجيات التحول في التعامل مع القدرات المتميزة كونها تمثل رأس المال البشري والإرث الحقيقي لأي مؤسسة، وإن الاستثمار في الموارد البشرية يعبر عن النجاح المستدام لأي دولة متقدمة ويشكل مسارها في استشراف مستقبل بناء يعتمد على كواهرها المحلية (مجلة صدى الموارد البشرية، 2018). وفي الوقت الراهن ينظر للموارد البشرية على أنها الأصول الأكثر قيمة للمؤسسة، وقد شكلت جمعية الإدارة العامة الدولية للموارد البشرية فريق عمل في يناير 2016 لرصد الجهود الحديثة والتحديات التي تواجه الموارد البشرية تحت عنوان (الموارد البشرية وأفاق التحول 2020: رؤى حول الموارد البشرية في القطاع العام) بهدف رسم إطار لمساعدة خبراء الموارد البشرية في القطاع الحكومي في المضي نحو مستقبل مشرق. وتترامى الجهود مع ما أصدرته مجموعة بوسطن الاستشارية في تقريرها لعام 2016 حول أهمية نهوض الحكومات لإجراء تحسينات جذرية على الأداء الحكومي من خلال رعاية الفئات المتميزة والاهتمام بقدرات ومواهب الموظفين والقيادات باعتبارهم المرتكزات الأولى للنهوض بالمؤسسات الحكومية (مجلة صدى الموارد البشرية، 2017). وتماشياً مع التوجهات العالمية نحو تنمية قدرات الموارد البشرية اتخذت دولة الإمارات العربية المتحدة سبيل رعاية المتميزين وتعزيز قدرات العاملين في القطاع الحكومي بسن تشريعات وسياسات داعمة ومحفزة لبيئة التميز الوظيفي وذلك بإطلاق جملة من المبادرات الحيوية التي تصب أهدافها في أفضل استثمار للموارد البشرية وكذلك صياغة استراتيجية الموارد البشرية للحكومة الاتحادية بتحديد هدف استراتيجي لتعزيز القدرات وتطويرها بما يوجه الدولة نحو التنافسية العالمية (استراتيجية الهيئة الاتحادية للموارد البشرية الحكومية 2017-2012، 2016). كما تحرص حكومة الإمارات على توجيه الجهود نحو بناء القدرات القيادية ورعايتها وصقلها لتكون رافداً يعكس توجهات الحكومة ويسهم في تمكين التميز الوظيفي. وقد أطلقت حكومة الإمارات في 2015م نموذج قائد القرن الـ 21، وطورته إلى نموذج الإمارات للقيادة الحكومية في 2018م الذي يمثل النموذج الأول من نوعه على مستوى العالم لبناء قدرات القيادات الحكومية، ويتضمن ثلاث مبادئ رئيسية لممارسات القيادة: النظرة المستقبلية والروح القيادية والانجاز والتأثير. في ذات السياق يسعى قيادات حكومة الإمارات والهيئات الاتحادية والمحلية إلى تعزيز التميز الوظيفي للقيادات التنفيذية والعاملين في القطاع الحكومي بشكل خاص، بتطوير برامج وجوائز التميز الوظيفي والمؤسسي، بما يعكس توجهات الدولة، ويوسع فرص التكريم والتقدير لكافة المتميزين في الدولة.

وفي مقولة لصاحب السمو الشيخ محمد بن راشد آل مكتوم حاكم دبي في وسم #علمتي الحياة، عبر حسابه على تويتر: "الإرث الحقيقي لأي قائد في أية مؤسسة هو صناعة الرجال". ووردت في مقولة صاحب السمو الشيخ الدكتور سلطان بن محمد القاسمي حاكم الشارقة في مقولته "إن بناء المستقبل مرهون ببناء الإنسان، والقوة البشرية تشكل أهم العوامل المؤثرة في تقدم الدول، وبناء الإنسان هو حجر الأساس في التنمية". بما يشير إلى أهمية بناء القدرات القيادية في الحكومات لتعكس بأثارها الإيجابية على صناعة التميز الوظيفي في المؤسسة. حيث أصبح من أبرز الضروريات أن ينظر الفرد لذاته كقائد في عمله ومؤسسته. وفي هذا السياق يمكن تفسير الإجابة الشهيرة للقائد العسكري نابليون بونابرت عندما سُئل: "كيف استطعت أن تولد الثقة في جيشك؟ فأجاب: كنت أرد بثلاث على ثلاث، من قال لا أفتر قلت له حاول، ومن قال لا أعرف قلت له تعلم، ومن قال مستحيل قلت له جرب" ذكره (المسار، 2003، صفحة 95).

1.2 مشكلة الدراسة

تنظر الحكومات المتقدمة بعين الاهتمام للأفراد الموهوبين والمتميزين ذوي القدرات الاستثنائية لمواجهة وتيرة التقدم والبقاء في ساحة المنافسة بذكاء، باعتبار الموارد البشرية المحور الرئيس لأي تغير وتطوير في مناحي الحياة. وبالتالي فإن التوجهات العالمية نحو الاهتمام بقدرات المورد البشرية يتضاعف يوماً عن يوم، ويوسع نطاقه على المستوى العالمي، وإن قصص نجاح المؤسسات الرائدة والمنظمات التي أولت اهتمامها بالعاملين وحجم المكاسب التي حققها أصبحت مرجعية لكل من يطمح النجاح واستدامة النتائج الباهرة، من مثل: جوجل وتويتر وأمازون...إلخ. وذلك لاعتمادها على تقدير مواهب وقدرات الموظفين المتميزين وتمكينهم بأفضل الوسائل. وفي حين كانت القطاعات العالمية تنظر إلى قدرات الموظفين ومواهبهم وتميز أدائهم بنظرة الفطرة الموروثة، باتت النظرة مغايرة بعد أن أثبتت الدراسات والأبحاث أن القدرات والسمات الإيجابية والابتكارية يمكن أن تكتسب ومرهونة بمدى رعايتها والاهتمام بها. ومن أبرز التجارب العالمية المطبقة نحو الاهتمام بقدرات وتميز الموارد البشرية في مجال العمل المؤسسي؛ تتمثل في جهود المنظمة الدولية للشباب، من خلال برنامج (جواز السفر) الذي طورته المنظمة لدعم قدرات الشباب وحفز مهاراتهم العملية بالتعاون مع مؤسسة جنرال إلكتريك. وتؤكد العديد من الدراسات والأبحاث حول فكرة أن الموظف قابل لاكتساب مهارات عمل جديدة وقابل لابتكار وتوليد أفكار خلاقة إذا ما توافرت له بيئة عمل محفزة وقيادة مشجعة. فقد جاءت نتائج الاستطلاع العالمي السابع عشر حول أرباب العمل الذي أجرته شركة برايس ووتر هاوس حول المديرين التنفيذيين، أن 77% من أرباب العمل يؤمنون أن نجاح الموظف في وظيفته لا يعتمد على شهادته العلمية، بقدر ما هو مرهون بمهاراته المكتسبة والاهتمام بتوفير فرص تعلم مناسبة لميوله وقدراته (مجلة صدى الموارد البشرية، 2017؛ International Youth Foundation، 2016، حنفي، 2010).

وعلى المستوى المحلي، تعتبر دولة الإمارات العربية المتحدة من الدول السبقة في تعزيز قدرات الموارد البشرية، والاهتمام بالعاملين والقيادات من مختلف المستويات. وفي ظل الجهود التي تبذلها الحكومة لمتابعة خطوات دعم وتمكين الموارد البشرية بصفتها المورد الأول والأهم لصناعة مستقبل الدولة وتحقيق التميز في مؤسسات القطاع الحكومي؛ تم تأسيس الهيئة الاتحادية للموارد البشرية الحكومية طبقاً للمرسوم بقانون اتحادي رقم (11) لسنة 2008 الذي أصدره صاحب السمو الشيخ خليفة بن زايد آل نهيان، رئيس الدولة حفظه الله. لتشكل بذلك انطلاقة مستقبلية واعدة في مجال تمكين القدرات وتنمية وتطوير الموارد البشرية في الوزارات والهيئات الحكومية الاتحادية في دولة الإمارات وتحقيق التناغم الوظيفي وتعزيز تنافسية الدولة استناداً إلى المفاهيم الحديثة والمعايير العالمية المطبقة في مجال إدارة الموارد البشرية. وقد أطلقت الهيئة استراتيجيتها حول الموارد البشرية الحكومية (2017-2012) بهدف استراتيجي لتعزيز وتطوير قدرات الموارد البشرية في الحكومة الاتحادية انطلاقاً من مبادرة جائزة الموظف المتميز (الهيئة الاتحادية للموارد البشرية الحكومية، 2019؛ مجلة صدى الموارد البشرية، 2018؛ استراتيجية الهيئة الاتحادية للموارد البشرية الحكومية 2017-2012، 2016).

وتماشياً مع منظومة التنافس الداخلي بين الموظفين والتميز المستدام، أطلقت بعض المؤسسات الحكومية والمحلية في دولة الإمارات العربية المتحدة برامج التنافس الداخلي بين الموظفين المتميزين في مؤسسات القطاع الحكومي، عبر تأسيس جوائز التميز الوظيفي وذلك تقديراً للإنجازات الشخصية وتعزيزاً للجهود المبذولة من مختلف فئات المتميزين وظيفياً في الدولة، منها على سبيل المثال لا الحصر: وسام أوائل الإمارات 2014م، ووسام رئيس مجلس الوزراء 2009م، برنامج الموظف المتميز في الحكومة الاتحادية "تستاهل" 2014م، جائزة خليفة التربوية 2007م، جائزة حمدان بن راشد آل مكتوم للأداء التعليمي المتميز 1998م، وجائزة الشارقة للتقوى والتميز التربوي 1995م... إلخ. كما اهتمت دولة الإمارات بتأهيل صفوف القيادات العليا والتنفيذية وبناء قيادات الصف الثاني والثالث، لضمان بيئة مهنية ملهمة للتميز والإبداع والابتكار، فدشنت برنامج قيادات حكومة دولة الإمارات عام 2008، وأطلقت ملامح استراتيجية حكومة الإمارات 2013/2011 في سبع ممكنات تصدرت بالممكن: موارد بشرية مؤهلة، وذلك من خلال التمكين والاستثمار في الموارد البشرية وبناء القدرات وتطوير القيادات لتحقيق رؤيتها في أن تكون من أفضل دول العالم بحلول 2021م (وزارة شؤون مجلس الوزراء والمستقبل، 2019). وانتهجت الحكومات المحلية في دولة الإمارات نهج الحكومة الاتحادية في تدشين برامج صناعة القيادات، فأصبح في كل إمارة برنامجاً مخصصاً لصقل وتعزيز مهارات القيادات نحو فهم سلوك القائد الملهم في بيئة العمل الحكومي وتطبيق أساليب دعم وتحفيز الموظفين للنجاح الوظيفي الذي يؤدي بدوره إلى التميز المؤسسي المستدام. منها على سبيل المثال: برنامج قيادات حكومة عجمان 2015م، وبرنامج الشيخ عبدالعزيز لبناء القادة 2015م، وبرنامج الشارقة لتطوير القدرات التابع لمؤسسة ربع قرن لصناعة القادة والمبتكرين 2016م،... إلخ.

وعلى الصعيد العلمي والبحثي، طُرحت العديد من الأديبات والدراسات المتعلقة بالموارد البشرية ومنطق المحفزات الداخلية والخارجية للموظفين، وتباينت آراء الباحثين ونتائج الدراسات حول مصدر إلهام الموظفين ما بين المحفزات والبواعث الذاتية والخارجية وأظهرت نتائج الدراسات آراء متوافقة ومتناقضة مع مفهوم أن للقائد أدوار أساسية تتمثل في إلهام الموظفين نحو التميز، وتعزيز قدراتهم لصناعة النجاح المؤسسي المستدام وورد عن حاكم دبي، صاحب السمو الشيخ محمد بن راشد آل مكتوم، نائب رئيس دولة الإمارات العربية المتحدة، رئيس مجلس الوزراء، العديد من التصريحات حول سمات القائد وتأثيره على نجاح المؤسسات، وأن القيادة فكر ودهاء، والقائد الناجح يصنع قيادات وليس أتباع. وفي كتاب (قصتي) لسمو حاكم دبي، ذكر في الوصية التاسعة (اصنع قادة) وقد نصت الوصية على أن: "صنع القيادات سر لا يفهمه إلا رجال تغلبوا على تضخم الأنا والذات، وفهموا أن أعظم إنجاز يصنعونه هو بناء البشر وليس الحجر" (آل مكتوم، 2018). يلاحظ أن في الوصية إشارة إلى سر من أسرار نجاح القيادات، وقد توافقت هذه الفكرة مع فكرة "وليامز جينز" في كتابه (دفع الناس للأعلى) حيث أشار إلى أن بناء قادة جدد يمثل أحد أهم أدوار القيادة العليا، والقائد وُجد لبناء صفوف القيادات المستقبلية. ذكره (الأخضر، 2018، صفحة 32). بينما جاء عن (أبيلو، 2017، صفحة 63) أن القيادة العليا في المؤسسة ليست هي المعنية بنجاح المؤسسة، بقدر ما أن النجاح عملية تزواج تشاركي بين كافة الموظفين بمختلف مستوياتهم الوظيفية وبين قيادات المؤسسة. ويؤيد (العصيمي، 2017، ص: 167) هذا التوجه من منظور أنه يتطلب التحول من التركيز على المهارات والسمات الفردية للقائد إلى تشكيل نموذج قيادي برؤية شاملة يعتمد على العمل التشاركي التكاملي مع قيادات المنظمة. كما يرى (القحطاني، 2001) أن القيادة تنبعث بثلاث مداخل: المدخل الفردي، الذي يعتبر أن القائد وما يتمتع به من صفات وسمات كفرد يدفع بالأفراد والجماعات المؤسسية لتحقيق النجاح، ويرى المدخل الاجتماعي، أن القيادة السليمة تنطلق من البيئة الاجتماعية التي تحتضن الأفراد ويمارس فيها القائد سلطته ومهامه ومسؤولياته، بينما المدخل التوفيقي الثالث، يجمع بين الفردي والاجتماعي على أنها عملية تفاعلية حيث لا تكفي مهارات وسمات القائد بقدر ما يتطلب تفاعل شخص القائد مع حيثيات المواقف الاجتماعية في الحياة اليومية.

إن هذا الاهتمام العالمي، والحكومي، والمحلي، وما ورد من أدبيات ودراسات عن محور بناء قدرات الموارد البشرية والقيادات الحكومية وعلاقة القائد بموظفي المؤسسة؛ أثار اهتمام الباحث وصوّب ملاحظاته اليومية والمباشرة لبيئة العمل الحكومي الذي عمل فيها على مدى تسع وعشرون عاماً، ولمس حجم التفاوت والاختلاف في السمات القيادية للقيادات الحكومية وأثرها على الموظفين وسمعة جهة العمل. وأثر القائد عندما يكون ذا سمات ملهمة في حشد الجهود نحو تميز موظفيه وما يعكسه على نتائج المؤسسة. ولأجل البدء في دراسة موضوع القيادة الملهمة وأثرها على التميز الوظيفي قام الباحث خلال مايو ويونيو ويوليو 2019م بطرح استطلاع رأي يهدف ملامسة انطباعات المجتمع حول أثر وأدوار القيادات تجاه تحفيز وتقدير جهود الموظفين المتميزين في الجهات الحكومية، طرح الاستطلاع في ثلاث أشكال لضمان تنوع فكر ومستويات المشاركين: الأول: بمقابلات شخصية مع المختصين في مجال التميز الوظيفي ومجال برامج تطوير القيادات الحكومية، الثاني: باستطلاع رأي عبر المنصة الإلكترونية "تطبيق جوجل" لرصد انطباعات العاملين في القطاع الحكومي من فئة الفائزين في الجوائز معتمداً على الأسئلة المفتوحة، والثالث: باستطلاع رأي إلكتروني عبر تطبيق قناة التواصل الاستمرام للعاملين في القطاع الحكومي بشكل عام. حيث أظهرت نتائج الاستطلاع تفاوتاً وتبايناً في آراء المختصين والخبراء حول أثر القيادة الملهمة على صناعة التميز الوظيفي، وأثر الدوافع الذاتية تعزي التميز الوظيفي، ورغم الجهود الجبارة لتعزيز قدرات الموظفين المتميزين العاملين في القطاع الحكومي، إلا أن هناك فجوة بحثية لم تثبت بعد عن أثر القيادات على تميز الموظفين وحصولهم على جوائز التميز الوظيفي في الدولة.

في هذا الصدد؛ فإن مشكلة الدراسة تتمحور حول إيجاد أثر القيادة الملهمة على صناعة التميز الوظيفي في القطاع الحكومي بدولة الإمارات. حيث يشكل التميز الوظيفي محور الدراسة بحصول الموظفين المتميزين في الجهات الحكومية على الجوائز التقديرية ويصنف متغيراً تابعاً يتوسط المتغيرات المستقلة والمؤثرة. وتشكل القيادة الملهمة متغيراً مستقلاً تنبثق منها أبعاد أنموذج الإمارات للقيادة الحكومية: (النظرة المستقبلية والروح القيادية والإنجاز والتأثير) وتتضمنها أبعاد القيادة التحولية متعددة العوامل الذي طورها باس وافييلو. وتشكل ممارسات الموظف المتميز متغيراً مستقلاً آخر تنبثق من معايير التميز الوظيفي المعتمدة في منظومة التميز الحكومي في الدولة والمتوافقة مع معايير التميز الوظيفي في المؤسسة الأوروبية للجودة الشاملة (الأداء والإنجاز، المبادرة والابتكار، التعلم المستمر)، بينما تشكل الدوافع الذاتية وتقدير الذات متغيراً مؤثراً، وتشكل جوائز التميز الوظيفي متغيراً مؤثراً آخر ذات أثر غير داخلي وخارجي على المتغير التابع.

بناء على مشكلة الدراسة يمكن أن تنبلور الأسئلة البحثية على النحو الآتي:

- السؤال الأول: ما درجة تأثير القيادة الملهمة على صناعة التميز الوظيفي في القطاع الحكومي بدولة الإمارات العربية المتحدة بأبعادها: النظرة المستقبلية، الروح القيادية، الإنجاز والتأثير، تعزي حصول الموظفين على جوائز التميز الوظيفي.

- السؤال الثاني: ما درجة تأثير ممارسات الموظف المتميز على صناعة التميز الوظيفي في القطاع الحكومي بدولة الإمارات العربية المتحدة بأبعادها: الأداء والإنجاز، المبادرة والابتكار، التعلم المستمر، تعزي حصول الموظفين على جوائز التميز الوظيفي.

- السؤال الثالث: ما درجة تأثير دافعية الإنجاز وتحقيق الذات ببعديه الدوافع الداخلية والخارجية، على العلاقة بين القيادة الملهمة والتميز الوظيفي، تعزي حصول الموظفين المتميزين على جوائز التميز الوظيفي.
- السؤال الرابع: ما درجة تأثير دافعية الإنجاز وتحقيق الذات ببعديه الدوافع الداخلية والخارجية، على العلاقة بين ممارسات الموظف المتميز والتميز الوظيفي، تعزي حصول الموظفين المتميزين على جوائز التميز الوظيفي.
- السؤال الخامس: ما درجة تأثير جوائز التميز الوظيفي بدولة الإمارات العربية المتحدة، على العلاقة بين القيادة الملهمة والتميز الوظيفي، تعزي حصول الموظفين المتميزين على جوائز التميز الوظيفي.
- السؤال السادس: ما درجة تأثير جوائز التميز الوظيفي بدولة الإمارات العربية المتحدة، على العلاقة بين ممارسات الموظف المتميز والتميز الوظيفي، تعزي حصول الموظفين المتميزين على جوائز التميز الوظيفي.

1.3 أهداف الدراسة

- تهدف هذه الدراسة إلى ما يلي:
- تحديد أثر القيادة الملهمة على صناعة التميز الوظيفي في القطاع الحكومي بدولة الإمارات العربية المتحدة بأبعادها: الروح القيادية، النظرة المستقبلية، التأثير والإنجاز
- تحديد أثر ممارسات الموظف المتميز في القطاع الحكومي بدولة الإمارات العربية المتحدة تعزي حصوله على جوائز التميز الوظيفي وفق معايير التميز المعتمدة: الأداء والإنجاز، المبادرة والابتكار، التعلم المستمر
- إيجاد أثر دوافع الإنجاز وتحقيق الذات لدى الموظف المتميز في القطاع الحكومي بدولة الإمارات العربية المتحدة على العلاقة بين القيادة الملهمة والتميز الوظيفي
- إيجاد أثر دوافع الإنجاز وتحقيق الذات لدى الموظف المتميز في القطاع الحكومي بدولة الإمارات العربية المتحدة على العلاقة بين ممارسات الموظف المتميز والتميز الوظيفي
- إيجاد أثر دوافع الإنجاز وتحقيق الذات لدى الموظف المتميز في القطاع الحكومي بدولة الإمارات العربية المتحدة على العلاقة بين القيادة الملهمة والتميز الوظيفي
- إيجاد أثر دوافع الإنجاز وتحقيق الذات لدى الموظف المتميز في القطاع الحكومي بدولة الإمارات العربية المتحدة على العلاقة بين ممارسات الموظف المتميز والتميز الوظيفي

1.4 أهمية الدراسة

- أ- القيمة العلمية: بالرغم من وفرة الدراسات حول التميز الوظيفي والموارد البشرية والقيادة وأنماطها وأثارها على بيئة العمل والموظفين؛ إلا أنه لم يتناول الباحثين أدبيات القيادة الملهمة وممارسات الموظف المتميز بالتأثير على التميز الوظيفي، ومن جانب آخر لم تتم الدراسات الكافية في دولة الإمارات حول تأثير جهود إدارات الجوائز، وتأثير الدوافع الذاتية للمتميزين يدفعهم للمشاركة في منافسات التميز، خاصة بوجود العديد من جوائز التميز في الدولة التي أفرزت مئات الموظفين المتميزين في القطاع الحكومي ورغم الاهتمام بالموارد البشرية في الحكومة الاتحادية. وبالتالي فإن هذه الدراسة تتناول بُعداً جديداً من شأنه أن يفتح أفقاً واسعاً للمعنيين بتوجيه الجهود نحو تعزيز وتمكين قدرات القيادات الحكومية وإلهامها لتحفيز وتشجيع المتميزين للمشاركة في مختلف منافسات جوائز التميز الوظيفي محلياً وعالمياً. كما تعد مرجعاً لحجم جوائز التميز في الدولة.
- ب- القيمة العملية: تكمن القيمة العملية للدراسة في الجانب التطبيقي؛ أنها الدراسة الأولى من نوعها - بحد علم الباحث - التي تطبق على مجتمع الإمارات عن أثر القيادة الملهمة على صناعة وتعزيز التميز الوظيفي، وتحديد على عينة المتميزين الحاصلين على الجوائز في دولة الإمارات. كما تنفرد هذه الدراسة عند تطبيق متغيراتها المستقلة والمؤثرة على المتغير التابع وإيجار الأثر والترابط بينها من خلال أنموذج مبادئ الإمارات للقيادة الحكومية: النظرة المستقبلية، والروح القيادية، والإنجاز والتأثير، بالربط مع معايير الموظف المتميز في برنامج الشيخ خليفة للتميز الحكومي - أوسمة رئيس مجلس الوزراء ومعايير التميز في المؤسسة الأوروبية للجودة الشاملة: الأداء والإنجاز، المبادرة والابتكار، التعلم المستمر. ويُعدّ دافعية الإنجاز لموراي وماكيلاند، وأدوار إدارات جوائز التميز الوظيفي في الدولة.

1.5 فرضيات الدراسة والأنموذج

- بناء على الدراسات السابقة ذات العلاقة بموضوع هذه الدراسة ومتغيراتها، فإنه يمكن تحديد عدد من الفرضيات البديلة (H1) على أنها تشكل إجابات افتراضية أو حلولاً مجازية متوقعة لأسئلة هذه الدراسة، عندما تفترض الدراسة بوجود علاقة بين متغيراتها لاستنتاج المسببات ومعالجة المشكلة البحثية على وفق منهجية علمية ودليل قاطع لأثر المسبب على السبب، وذلك على النحو الآتي:

الفرض الأول: توجد علاقة ذات دلالة إحصائية عند مستوى دلالة ($\alpha \leq 0.05$)، للقيادة الملهمة بأبعادها (الروح القيادية، النظرة المستقبلية، التأثير والإنجاز) على صناعة التميز الوظيفي في القطاع الحكومي بدولة الإمارات، تعزي حصول الموظفين على جوائز التميز الوظيفي.

الفرض الثاني: توجد علاقة ذات دلالة إحصائية عند مستوى دلالة ($\alpha \leq 0.05$)، لممارسات الموظف المتميز بأبعادها (الأداء والإنجاز، المبادرة والابتكار، التعلم المستمر) على صناعة التميز الوظيفي في القطاع الحكومي بدولة الإمارات العربية المتحدة تعزي حصوله على جوائز التميز الوظيفي.

الفرض الثالث: أنه توجد علاقة ذات دلالة إحصائية عند مستوى دلالة ($\alpha \leq 0.05$)، لدافعية الإنجاز وتحقيق الذات على العلاقة بين القيادة الملهمة والتميز الوظيفي في القطاع الحكومي بدولة الإمارات العربية المتحدة، تعزي حصول الموظفين المتميزين على جوائز التميز الوظيفي.

الفرض الرابع: أنه توجد علاقة ذات دلالة إحصائية عند مستوى دلالة ($\alpha \leq 0.05$)، لدافعية الإنجاز وتحقيق الذات على العلاقة بين ممارسات الموظف المتميز والتميز الوظيفي في القطاع الحكومي بدولة الإمارات العربية المتحدة، تعزي حصول الموظفين المتميزين على جوائز التميز الوظيفي.

الفرض الخامس: أنه توجد علاقة ذات دلالة إحصائية عند مستوى دلالة ($\alpha \leq 0.05$)، لجوائز التميز على العلاقة بين القيادة الملهمة والتميز الوظيفي في القطاع الحكومي بدولة الإمارات العربية المتحدة، تعزي حصول الموظفين المتميزين على جوائز التميز الوظيفي.

الفرض السادس: أنه توجد علاقة ذات دلالة إحصائية عند مستوى دلالة ($\alpha \leq 0.05$)، لجوائز التميز على العلاقة بين ممارسات الموظف المتميز والتميز الوظيفي في القطاع الحكومي بدولة الإمارات العربية المتحدة، تعزي حصول الموظفين المتميزين على جوائز التميز الوظيفي.

حيث تدور حبكة الدراسة حول المتغير التابع والمتمثل في التميز الوظيفي، تحيط به أربعة محاور تمثل متغيرات الدراسة، متغيران مستقلان ومتغيران مؤثران، ومن خلال العرض السابق لفرصيات الدراسة يمكن اعتماد نموذج الدراسة على النحو الآتي:

المتغير التابع: التميز الوظيفي، ويمثل البعد الذي يتلقى تأثيراً من المتغيرات الأخرى. ويتمحور حوله مفاهيم الدراسة محاولة إيجاد تفسير للعوامل التي تؤثر على التميز الوظيفي في القطاع الحكومي.

المحور الأول المتغير المستقل والتابع: تأثير القيادة الملهمة على التميز الوظيفي، ويمثل البعد الأهم الذي يحرك المتغير التابع طردياً في الاتجاه الإيجابي أو السلبي، من خلال قياس مدى توافر أبعاد نموذج القيادة الحكومية كممارسات داعمة للتميز في القطاع الحكومي.

المحور الثاني المتغير المستقل والتابع: تأثير ممارسات الموظف المتميز على التميز الوظيفي، ويمثل بعداً آخر يحرك المتغير التابع طردياً في الاتجاه الإيجابي أو السلبي، من خلال قياس مدى تأثير ممارسات الموظف في تميز أداءه وحصوله على جوائز التميز الوظيفي.

المحور الثالث المتغير المؤثر أو الملطف: تأثير دافعية الإنجاز وتحقيق الذات: ويمثل بعداً مؤثراً على العلاقة بين المتغير التابع والمتغير المستقل وفي درجة زيادة التأثير أو خفضه من خلال قياس أثر الدوافع الداخلية والدوافع الخارجية على التميز الوظيفي.

المحور الرابع المتغير المؤثر أو الملطف: تأثير جوائز التميز الوظيفي، ويمثل بعداً مؤثراً آخر يساهم في زيادة التأثير أو خفضه بين المتغيرات المستقلة والمتغير التابع من خلال فحص أدوار إدارات الجوائز وملائمة وجدوى معايير التميز.

1.6 مصطلحات الدراسة

القيادة: فن التأثير في الآخرين وتوجيه جهودهم وطاقتهم نحو تحقيق الأهداف المرجوة.

القيادة الملهمة: ما يُلقي في روح القائد من قدرة إبداعية تنفع المرؤسين نحو العمل بأعلى مستويات التناغم والروح الإيجابية والدافعية للنجاح والتميز. صناعة التميز: حرفة أو ملكة يختص بها البعض في إلهام وتوجيه الآخرين وتمكينهم لإطلاق قدراتهم الكامنة وبلوغ التميز، والصناعة إحدى سمات القائد الذي يتغلب على الأنا والذاتية في التعامل مع المرؤسين.

التميز الوظيفي: منطقتي وفلسفة إدارية تعتمد على تعظيم التفوق والتفرد في الأداء لتحقيق نتائج ملموسة على أرض الواقع ويشهد لها بالبنان. دافعية الإنجاز: مثيرات داخلية وخارجية مورثة ومكتسبة تحرك سلوك الأفراد نحو تحقيق الأهداف أو إشباع حاجة.

جوائز التميز الوظيفي: أدوات ومقاييس مقننة لتقييم الأداء الوظيفي، تهدف إلى تحفيز وتقدير جهود الموظفين المتميزين في جهة العمل.

1.7 الدراسات السابقة

بالعودة للأدبيات المتعلقة بموضوع الدراسة ومتغيراتها، نجد أن الباحثين قد تناولوا موضوع القيادة وأنماطها من أطر مختلفة، وآخرون أسهبوا في دراسة الدافعية وأثرها على سلوك البشر وما تعكسه على الوظيفة، ونلاحظ أن هناك ندرة في الدراسات المتعلقة بجوائز التميز الوظيفي بشكل علم؛ إلا أن الدراسات لم تنظر إلى الربط بين القيادة الملهمة وأثرها على تعزيز التميز الوظيفي، وأثر دافعية الإنجاز على التميز، وتحديدًا، لم ترد أي دراسة مطبقة على مجتمع دولة الإمارات العربية المتحدة، خاصة بالتطبيق على فئة المتميزين

دراسة (العنزي 2015)

دراسة عربية حول: القيادة الملهمة كمدخل لتطوير الأداء وتحقيق التميز المدرسي، طبقت في وزارة التربية والتعليم بدولة الكويت للمقارنة بين المعلم كقائد ملهم ولطلابه والمعلم كمدبر للفصل. وكيفية الاستفادة من القيادة الملهمة في تطوير الأداء وتحقيق التميز المدرسي من خلال دور المعلم كقائد ملهم؟ هدفت إلى تناول دور المعلم في الانتقال إلى قائد ملهم يلمه فئة الطلاب ويدفعهم لممارسة سلوكيات تؤدي إلى تحقيق التميز المدرسي، والارتقاء بمستوى وكفاءة أداء الطلاب داخل فرق العمل. خلصت نتائج الدراسة إلى أن القائد الملهم يؤثر في السلوكيات المنعكسة على الطلاب والمعلمين في أربع جوانب رئيسية، ذكر الباحث أنها: تؤثر على مستويات التفكير العليا لدى الطلبة، وعلى قدرات التصميم والابتكار لديهم، وعلى رفع قدراتهم في التواصل مع الآخرين وإدارة الاجتماعات، وعلى تطوير الأداء المدرسي. وقد أوصى الباحث بتمكين وتأهيل الإدارة العليا والمعلمين في مفاهيم القيادة الملهمة وتشجيع الطلبة على فهم سلوك القيادة الملهمة وتطبيقها خلال فرق العمل

دراسة (اللوحي، 2017)

دراسة عربية أخرى حول: دور القيادة الملهمة في تعزيز الالتزام التنظيمي لدى العاملين في وزارة الأشغال العامة والإسكان بدولة فلسطين، هدفت إلى الكشف عن واقع القيادة الملهمة في وزارة الأشغال ومستويات الالتزام التنظيمي للعاملين في الوزارة. طبقت على (140) موظفًا،

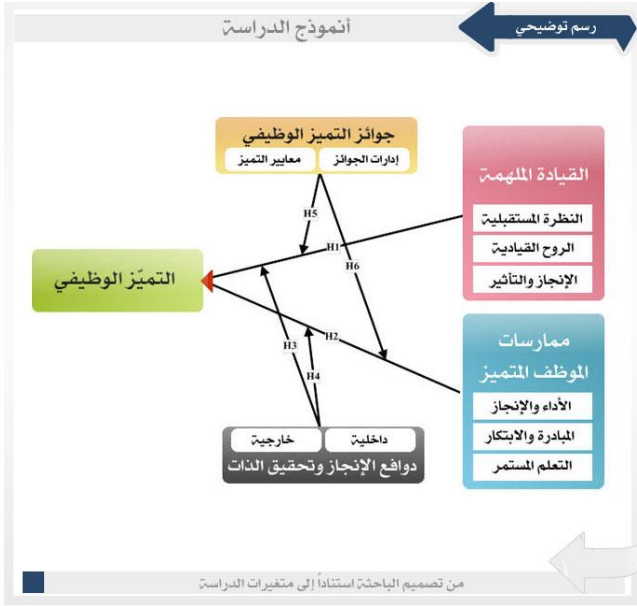

واستخدمت الاستبانة كأداة للدراسة، تحمل عبارات تحليلية ما بين أبعاد القيادة الملهمة والالتزام التنظيمي. أظهرت نتائج الدراسة أنه يوجد تأثير متوسط لأبعاد القيادة الملهمة على تعزيز الالتزام التنظيمي، بنسبة بلغت (39.9%) بينما يعود التأثير الأكبر لمتغيرات أخرى لم ترد في الدراسة. وأوصى الباحث بتعزيز الجهود وتكثيفها لزيادة تواجد أبعاد القيادة الملهمة لدى القادة بوزارة الأشغال العامة والإسكان بمحافظة قطاع غزة وتكثيف الجهود لتعزيز الالتزام التنظيمي بعقد الدورات التدريبية والندوات وورش العمل لتطوير مهارات وكفاءة العاملين وتنمية قدراتهم ومعلوماتهم وترسيخ مبدأ العدالة والشفافية في الترقيات والحوافز والمكافآت.

دراسة (Vallina, Simone, & Guerrero, 2020)

دراسة حديثة طبقت على البنوك الإيطالية والإسبانية حول: الجانب الإنساني للقيادة: وأثر القيادة الملهمة على خصائص التابعين وتحقيق السعادة في العمل. طبقت على (389) موظفًا في الخدمات المالية، يعملون في الخطوط الأمامية للخدمات المصرفية الإيطالية والإسبانية في أكبر (5) بنوك من إسبانيا وإيطاليا، صمم الباحث استبيان إلكتروني يتضمن أربعة محاور لقياس جوانب التابعين وفق باس وأفيليو: التفكير المستقل والنشاط والتعلم التشط والابتكار. وقد أظهرت نتائج الدراسة أن القيادة الملهمة تمارس تأثيراً أكثر إيجابية عندما تكون خصائص التابعين أكثر إيجابية، وإن القيادة الفاعلة قد تلهم الأتباع وتعزز أدوارهم نحو أداء متقن، حيث يركز القادة المهتمون على إثارة عواطف التابعين عن طريق اللغة والرموز والصور. وسلطت النتائج على أهمية فهم احتياجات التابعين لزيادة تأثيرها على فعالية القيادة الملهمة.

دراسة (Mitchell, Boyle, 2019)

أما دراسة تأثير القيادة الملهمة والمزاج الإيجابي على الابتكار والتميز المهني، هدفت إلى دعم الفرق المتعددة التخصصات في سياسة الرعاية الصحية وتوجيه قدرتها لتطوير حلول مبتكرة لتحديات الخدمة والرعاية المستعصية. طبقت على (60) فريق للرعاه الصحية في المملكة المتحدة، سلطت الدراسة الضوء على قدرات القيادة الملهمة في تعزيز الابتكار لدى فرق العمل والعوامل المؤثرة على الابتكار. وفرضت تناقضاً بين قدرة القادة على توليد الأفكار الابتكارية وبين فهم الظروف المحيطة بالتابعين واحتياجاتهم. بينت النتائج أن العلاقة طردية بين فرضيات الدراسة من حيث تأثير أسلوب القيادة وارتفاع المزاج الإيجابي على تعزيز الابتكار لدى فرق العمل، مما يدعم هذه النتائج في توفير رؤى مهمة للموارد البشرية عند الشروع في تصميم برامج التطوير لفرق العمل.

كما وردت العديد من الأدبيات حول أنماط القيادة والسمات القيادية وأثرها على أداء العاملين، وأثر القيادة التحويلية والتبادلية كأقرب نمط للقيادة الملهمة. على تحفيز الموارد البشرية وإطلاق الإبداع التنظيمي والالتزام والتميز، منها:

دراسة (Basit, Sebastian, & Hassan, 2017)

حول أثر النمط القيادي على أداء الموظف: دراسة حالة منظمة خاصة، وتهدف إلى تحديد تأثير الأسلوب القيادي على أداء الموظفين، وقد طبقت على شركة في سلانجور - ماليزيا. استهدفت الدراسة (100) موظف وحدثت أداة الدراسة في الاستبيان لقياس بعدي القيادة الديمقراطية والاستبدادية وكذلك أداء الموظف. أظهرت نتائج الدراسة أن للقيادة الديمقراطية أثر إيجابي مرتفع على أداء الموظفين، وأظهرت انخفاض أداء الموظف في حال القيادة الاستبدادية، وأوصت الدراسة بتشجيع القيادات الماليزية بتبني نمط القيادة الديمقراطية وإشراك أعضاء الفريق في عملية صنع القرار كما ينبغي على القادة الماليزيين تشجيع الابتكار والعمل الجماعي والإبداع الذي يؤدي إلى الرضا الوظيفي وزيادة الإنتاجية وبالتالي زيادة الأداء.

دراسة (الإخضر، 2018)

حول دور القيادة التحويلية في تحقيق التميز التنظيمي بالمؤسسة الاقتصادية- دراسة حالة مجمع كوندور بروج بو عريريج. هدفت إلى معرفة واقع التميز التنظيمي في المنظمات الاقتصادية الجزائرية، وأثر أبعاد القيادة التحويلية: التأثير المثالي، الاستثارة الفكرية، الاعتبارات الفردية، التحفيز الإلهامي، والتمكين على أبعاد التميز التنظيمي: تميز الموارد البشرية، تميز الاستراتيجية، تميز الهيكل التنظيمي، وتميز الثقافة المؤسسية. أظهرت نتائج الدراسة وجود مستوى متوسط لسلوكيات القيادة التحويلية في المؤسسة محل الدراسة، حيث أظهرت النتائج في ثلاثة أبعاد مرتفعة: التأثير المثالي والتحفيز الإلهامي والاستثارة الفكرية، ومتوسطة في بعدين: الاعتبارات الفردية والتمكين. بينما جاءت النتائج متوسطة في كافة أبعاد التميز التنظيمي، كما أظهرت النتائج وجود علاقة ارتباطية طردية قوية بين المتغيرين. وأوصى الباحث بضرورة دعم وتطوير الاتجاهات نحو الممارسة الفكرية والعملية لنظرية القيادة التحويلية للقيادات في المؤسسة، وتهيئة مناخ العمل المناسب ونفويض الصلاحيات وتمكين القيادات وصلف مهاراتهم في التعلم مع المرؤوسين

دراسة (الرشيد، 2018)

أما دراسة القيادة التحويلية وعلاقتها بالإبداع التنظيمي لدى عمداء ورؤساء الأقسام بالجامعات الحكومية والأهلية بمدينة الرياض. فقد طبقت على القطاع الحكومي شملت (8) جامعات سعودية حكومية وبلغ حجم العينة (147) من عمداء الكليات ورؤساء الأقسام. وهدفت الدراسة إلى تحديد مستوى ممارسة القيادات الأكاديمية لنمط القيادة التحويلية، وأثره على الإبداع التنظيمي. توصلت نتائج الدراسة إلى أن كافة أبعاد القيادة التحويلية تملس بمستوى مرتفع، وأن ممارسة الإبداع التنظيمي جاء بجميع أبعاده بمستوى متوسط. وقد أوصى الباحث بإعادة النظر في المعايير التي يتم في ضوءها اختيار القيادات في الجامعة من رؤساء أقسام وعمداء للكليات ليكونوا أكثر انسجاماً مع متطلبات التغييرات المعاصرة. كما أوصى بضرورة توافر مناخ لاستقطاب المبدعين في الوظيفة، وتكثيف برامج التمكين والتدريب.

وردت أيضاً العديد من الأدبيات المتعلقة بتأثير القيادة على دافعية الإنجاز وأداء الموظفين، ومثالها:

دراسة (Shafi, Song, & Sarker, 2020)

حول: أثر القيادة التحويلية على إبداع الموظفين: بالتأثير على الدوافع الداخلية للموظفين. تهدف الدراسة إلى التحقق من تأثير القيادة التحويلية في تحفيز إبداع الموظفين في شركة البرمجيات الباكستانية. طبقت على (164) من العاملين بمستويات مختلفة من (31) شركة للبرمجيات. صمم الباحث الاستبيان كأداة للدراسة بأبعادها الأربعة في القيادة التحويلية لأبعاد باس وأفيليو. وقد أظهرت نتائج الدراسة إلى أن التأثير المثالي، والتحفيز الفكري، والتحفيز الإلهامي، لها تأثير مرتفع على إبداع الموظفين والابتكار التنظيمي، باستثناء الاعتبارات الفردية حيث لم تظهر التأثير. كما أظهرت تأثير مرتفع للتفاعل والاتصال المباشر وتعزيز الابتكار من خلال إلهام الموظفين للتفكير خارج الصندوق بما يؤثر على الابتكار التنظيمي في المؤسسة.

دراسة (حسين، 2017)

حول: النمط القيادي للمدراء وعلاقته بدافعية الإنجاز لدى الطاقم الإداري. طبقت الدراسة على المركات الرياضية الجوارية في ولاية جيجل الجزائرية. هدفت الدراسة إلى التعرف على الأنماط القيادية السائدة في المركات الرياضية: النمط القيادي الديمقراطي والأوتوقراطي والوضوي، وطبيعة العلاقة الارتباطية بين النمط القيادي ومستوى دافعية الإنجاز لدى الطاقم الإداري. وطبقت على عينة قصدية بطريقة المسح الشامل على (46) موظفًا من موظفي المركات الرياضية الجوارية لولاية جيجل بتوزيع استبيان يتضمن مقياس دافعية الإنجاز ومقياس النمط القيادي. أظهرت نتائج الدراسة العامة أنه يوجد علاقة ارتباطية طردية بين السلوك القيادي ودافعية الإنجاز لدى الطاقم الإداري، أي أنه كلما زاد نمط السلوك القيادي الديمقراطي كلما ارتفعت دافعية الإنجاز. بينما أظهرت نتائج عكسية في توافر النمط الأوتوقراطي فكلما ارتفع السلوك القيادي الأوتوقراطي انخفضت الدافعية، وأظهرت نتائج متوسطة في نمط القيادة الفوضوي أو الحر. وقد أوصى الباحث بتشجيع القيادات في ممارسة السلوك القيادي الديمقراطي لتحفيز الموظفين ورفع دوافعهم نحو العمل، وإحضار المرشحين للمهام القيادية لاختبار قياس السلوك القيادي قبل ترقيتهم للمناصب، وتأهيل وتمكين القيادات لرفع كفاءتهم القيادية.

دراسة (محمد، أسعد، وناصر، 2017)

وطبقت في السودان، حول: دور الرضا الوظيفي في تحقيق دافعية الإنجاز لدى العاملين في وزارة المالية بولاية البحر الأحمر. هدفت إلى التعرف على دوافع الإنجاز وعلاقتها بالرضا الوظيفي، تكون مجتمع الدراسة من (357) موظفاً في وزارة المالية. أظهرت نتائج الدراسة عن وجود علاقة ارتباطية موجبة ذات دلالة إحصائية بين الدافعية الداخلية للإنجاز وبين ارتفاع الأداء الوظيفي والرضا العام، كما أظهرت أن حوافز العمل المتمثلة في طبيعة العمل أكثر ارتفاعاً من الحوافز المالية. في ضوء النتائج أوصت الدراسة بوضع نظام للحوافز في المؤسسة يكفل العدالة بين الموظفين، وطرح مبادرات تقدير العاملين المتميزين في الأداء

دراسة (Sony, 2019)

أما في مجال التميز الوظيفي فقد أجريت دراسة حول التميز التشغيلي المستدام في المنظمات. وجهة نظر تكاملية، فقد تبنت الدراسة نموذجاً لاستدامة التميز التشغيلي باعتبار الجوانب الاجتماعية والاقتصادية والبيئية للتميز التشغيلي. وتهدف إلى التحقق من كيفية تنفيذ مبادرة التميز التشغيلي المستدام في المنظمة. واستخدمت الدراسة نتائج وتقرير من قواعد البيانات الإلكترونية، واقتصر نطاق الدراسة على الثلاثين عاماً الأخيرة في قواعد البيانات التي تم تضمينها في الدراسة (1988-2018). وأظهرت النتائج فاعلية برامج التميز الوظيفي في نجاح المبادرات قصيرة المدى، ولكنها لم تبين نجاحها على المدى البعيد، مما يستدل إلى غياب عنصر الاستدامة في التميز التشغيلي في المنظمة. كما أثبتت الدراسة إلى أن معظم نماذج التميز التشغيلي تفوقها الممارسة النشطة وتفتقر إلى الأساس حيث لا يوجد منهج موحد لتنفيذ الامتياز التشغيلي والحفاظ عليه كما انفصلت المؤسسات يعود لغياب الثقافة التنظيمية والجودة والتميز. وبينت النتائج تفاوتاً في المستويات بين التأثير في الجوانب الاجتماعية والاقتصادية والبيئية للتميز التشغيلي.

دراسة (Rassel Kasseem, Ajmal, & Khan, 2016)

فقد أجريت على مجتمع الإمارات لثلاثة باحثين من جامعة أبوظبي حول: العلاقة بين الثقافة التنظيمية وتميز الأعمال، دراسة حالة مجتمع دولة الإمارات العربية المتحدة. تهدف الدراسة إلى إيجاد أثر الفوز بجوائز التميز المؤسسي على تحسين الثقافة المؤسسية من خلال تأثير أربع مكونات: ثقافة رسالة المؤسسة، القدرة على التكيف، تأثير تكنولوجيا المعلومات، والاتصال، وقد استهدفت الشركات في قطاع الأعمال وطلبت على شركة إماراتية فازت بجائزة خليفة للامتياز، وبلغت عينة الدراسة (45) مديراً من فئة الموظفين المتميزين الحاصلين على جوائز التميز الوظيفي، وزرع عليهم استبيان مكون من (32) سؤالاً، وبلغ عدد الاستبيانات المسترجعة (29) استبانة بمعدل استجابة 64.44%. أظهرت النتائج وجود علاقة إيجابية بين مكونات الثقافة التنظيمية والتميز التجاري بشكل عام. كما أظهرت وجود تباين بين تأثير أنواع الثقافة المستخدمة، حيث أظهرت نتائج ثقافة رسالة المؤسسة بشكل مرتفع بينما تنخفض ثقافة القدرة على التكيف، وتتوسط نتيجة تأثير تكنولوجيا المعلومات والاتصال. لديها أكثر من غيرها. وأوصت الدراسة بإعطاء الأولوية لأنواع الثقافة التنظيمية الأكثر توافقاً مع ممارسات التميز في العمل كما وجهت إلى المزيد من الدراسات باستخدام عينة أكبر من الفائزين في الجوائز، وقوائم جوائز أخرى

دراسة (الجرادية والحجازية، 2015)

دراسة أخرى حول الجوائز عن: دور جائزة الملكة رانيا العبدالله للمعلم المتميز في تطوير الأداء التربوي للمعلمين في مديرية التربية والتعليم في شمال غرب البادية، بلغ مجتمع الدراسة (248) معلماً من الذكور والإناث المشاركين برامج التأهيل والتدريب على معايير الجائزة في الفترة من 2006 إلى 2012م تم اختيار العينة بنسبة (36%) من مجتمع الدراسة وبالطريقة العشوائية. استخدمت الباحثان استبيان مكون من (74) عبارة تعبر عن (9) معايير في مجالات الجائزة. كشفت نتائج الدراسة أن هناك تأثير للجائزة في جميع الأبعاد. وجاء بعد أخلاقيات المهنة في المرتبة الأولى، يليه بعد فلسفة الشخصية. كشفت النتائج أيضاً عن وجود فروق ذات دلالة إحصائية في أداء التدريس يمكن أن تعزى إلى النوع الاجتماعي لصالح المعلمين الذكور، بينما لم تكن هناك فروق ذات دلالة إحصائية في أداء التدريس يمكن أن تعزى إلى المؤهلات وسنوات الخبرة وعدد المشاركة في الجائزة. وفقاً للنتائج، أوصت الباحثان بتطوير المشاركة المجتمعية وزيادة عدد المعلمين الممنوحين.

2- المحور الثاني: الإطار النظري

تؤكد النظريات العلمية في الفكر الإداري الحديث ودراسات الشخصية، أن الموارد البشرية تشمل الأصول لأي مؤسسة تطمح في النجاح وزيادة الانتاجية، وإن الاعتراف بشخص الفرد وتقديره بالتقدير الملائم لرعياته واحتياجاته ورفع معنوياته في العمل؛ يعد المدخل الأول لاستمرارية تفوق المؤسسة وزيادة أرباحها. حيث اعتبرت النظريات الحديثة الإنسان كائن عاطفي يتأثر بالمشاعر والانفعالات والتي من شأنها أن تزيد الانتاجية التنظيمية إذا ارتفع مؤشر رضاه المهني، كما ركزت على العلاقات غير الرسمية بين القائد والمؤسسين كأساس لنجاح العمل. وترتبط معطيات هذه النظريات مع الدراسة الحالية في أربع نظريات (الشكل: 2.1) نظرية الإدارة العلمية، نظرية العلاقات الإنسانية، النظرية السلوكية، ونظرية دافعية الإنجاز وتحقيق الذات. ويمثل التميز الوظيفي في القطاع الحكومي محور اهتمام الباحث ويمثله كمتغير تابع للدراسة، للبحث والتقصي عن أثر القيادة الملهمة على تحريك الدوافع الداخلية والخارجية للموظف من خلال وسائل التقدير والتعزيز الملائمة، وأثر ممارسات الموظف ودوافع الذاتية نحو الإنجاز تعزى تميز أداءه وتفرده في الأداء عن زملاءه في الوظيفة.

2.1 إدارة الموارد البشرية

إن الاهتمام بالموارد البشرية ليس وليد العصر الحديث، فقد كان محل اهتمام الباحثين وخبراء الاقتصاد منذ القدم، في محاولة لإيجاد نظام مهني عدل في المنظمات يضمن الحقوق والواجبات لفئة العاملين في القطاعات المختلفة. إلا أنه برز الاهتمام بالموارد البشرية في العصر الحديث كعلم متخصص وممارسات إدارية ناجحة، نتيجة التطور الهائل في مناحي الحياة ودخول عالم التكنولوجيا التي أدت إلى تحولات جذرية في المفاهيم الإدارية والهياكل التنظيمية، واستقطاب القدرات الابتكارية وذلك وفقاً لاحتياجات العصر السياسية والاقتصادية والاجتماعية. فقد أشارت نتائج الدراسات وآراء الباحثين وخبراء الاقتصاد أن العنصر الحاسم في تميز المنظمات وتحقيق التفوق وكفاءة الإنتاج تتمثل في تطوير وتنمية الموارد البشرية والاحتفاظ بالقدرات الموهوبة والتميز في بيئة العمل. وبذلك كانت مرحلة القرن العشرين بدايات التحول من مصطلح إدارة الأفراد أو شؤون الأفراد إلى ظهور مصطلح الموارد البشرية مع تسليط الضوء على الممارسات الحديثة في التنمية والتطوير والتمكين والاستقطاب والاحتفاظ المواهب (السلامي، 2001؛ كافي، 2018). وتعتبر إدارة الموارد البشرية وحدة من أهم الإدارات في المنظمات الحكومية والخاصة على حد سواء، حيث تركز على العمليات الرئيسية المتعلقة بتخطيط الموارد، والتعيين، والتقييم، والتطوير والتنمية، وغيرها من الوظائف التي تعكس الشمولية والتكامل في توزيع

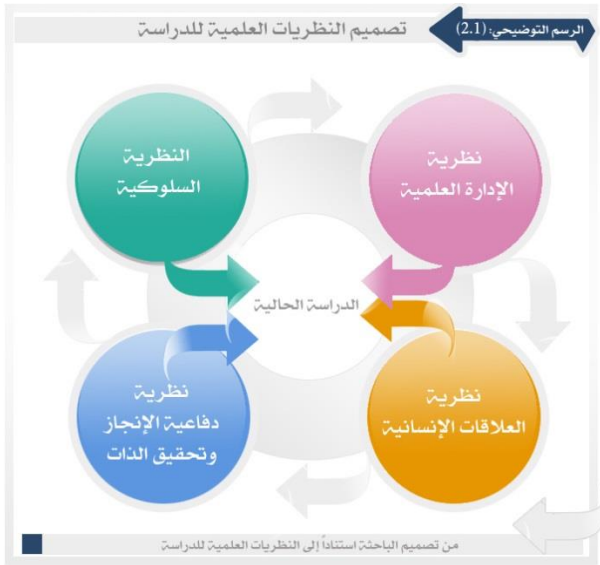

على العمليات الرئيسية المتعلقة بتخطيط الموارد، والتعيين، والتقييم، والتطوير والتنمية، وغيرها من الوظائف التي تعكس الشمولية والتكامل في توزيع

المهام وتوصيفها في هيكل المؤسسة. وقد تعددت تعريفات الباحثين والخبراء لمفهوم إدارة الموارد البشرية، عرفها شاويش أنها: "النشاط الإداري المتعلق بتحديد احتياجات المشروع من القوى العاملة، وتوفيرها بالأعداد والكفاءات المحددة، وتنسيق الاستفادة من هذه الثروة البشرية بأعلى كفاءة ممكنة" (ذكره (بوهندة وبالهادي، 2014، الصفحات 17-18)). وعرفها فليبو أنها: "تخطيط، وتنظيم، ومراقبة، واستقطاب، وتنمية، ومكافأة، وتكامل، وصيانة الموارد البشرية؛ لغرض تحقيق أهداف المنظمة" (حنفي، 2010). وعرفها بلينج أنها: مجموعة الأنشطة للحفاظ على المورد البشري؛ بهدف تزويد منظمات الأعمال ببيد عاملة منتجة، ومستقرة، وراضية" (حسن ح، 2011). كما عرفها (كداو، 2016، صفحة 13) أنها: نموذج متميز لإدارة البشر لتحقيق الميزة التنافسية من خلال صياغة استراتيجيات التحول إلى الكفاءة والولاء المؤسسي". أما السلمي فقد عرفها أنهت: "نظام متكامل ومترابط يتضمن مجموعة من العمليات والأنشطة المتصلة والمتداخلة" (السلمي، 2001).

2.2 التميز الوظيفي في القطاع الحكومي

يمثل القطاع الحكومي القطاع الأهم في أي دولة، حيث يشمل كافة الوزارات والجهات الخدمية والمؤسسات العامة التي تقع تحت إشراف جهاز الدولة وتمول من ميزانيتها. ينظر إليه أنه جهاز يقدم مجموعة خدمات غير ربحية للمجتمع، من مثل: الأمن والتعليم والصحة، والمعاشات، والداخلية، والثقافة والحكومة، وإلخ ويشار في علم الإدارة إلى وظائف القطاع الحكومي، إلى العمل النظامي المستقر في أحد المؤسسات الحكومية والوزارات المملوكة للحكومة، مقابل أجر مالي يصرف من ميزانية الدولة. وتتميز الوظيفة الحكومية بنوع من الاستمرارية والاستقرار والثبات، وسلم من التعاقب الوظيفي والترقيات. ويخضع الموظف في القطاع الحكومي لبعض الامتيازات من مثل: التدريب والتأهيل والتحفيز وتحسين مستوى الأداء (حسن ح، 2011). وفقاً لقرار مجلس الوزراء رقم (15) لسنة 2013م بشأن لائحة الموارد البشرية في الجهات الحكومية الاتحادية في دولة الإمارات العربية المتحدة، فقد ورد تعريف الوظيفة أنها: "كل من يشغل إحدى الوظائف الواردة في ميزانية الجهة الاتحادية التي يعمل لديها" وورد تعريف الجهة الاتحادية، أنها تشمل: "الهيئات والمؤسسات والمكاتب التابعة للحكومة الاتحادية التي تسري عليها أحكام لائحة الموارد البشرية الحكومية" (قانون الموارد البشرية في الحكومة الاتحادية، 2016).

تؤكد النظريات العلمية والدراسات الحديثة في مجال الإدارة والجودة والتميز المؤسسي، أن التميز الوظيفي صفة مكتسبة، وأنها ترتبط بعدد من المثيرات التي تحرك دوافع الموظف لتحقيق نشوة أو سعادة محددة. وأنه يمكن صناعة الأفراد المتميزين باستشارة قدراتهم استناداً إلى عدد من العوامل والمعايير، كالتحفيز والتقدير والتدريب والتأهيل المهني والتخصصي (البارودي، 2016). حيث يشير مصطلح الصناعة إلى الصنعة من أصل (فعل) صنع، وصنع يصنع صنعة، وصناعة فهو صانع. وصنع الشيء أي عمله وأنشأه. والصناعة حرفة الصانع وتشمل كل علم أو فن مارسه الإنسان حتى يمهّر فيه ويصبح حرفة له. والصنع: إجادة الفعل، فكل صنع فعل، وليس كل فعل صنعة، ولا ينسب فعل الصنع إلى الحيوانات والجمادات كما ينسب إليها الفعل (قاموس المعاني، 2010). والصناعة اصطلاحاً تشير إلى تحويل المواد الخام في الطبيعة إلى مواد قابلة للاستخدام. وهي اختلاق الشيء من عدمه، أو إعادة شكل الشيء عما كان عليه. والصناعة في الاصطلاح ملكة نفسانية ذاتية المصدر ينتج عنها أفعال اختيارية تجاه موقف أو شخص. في القرآن الكريم قال تعالى: (وَاصْطَنَعْتُكَ لِنَفْسِي) (القرآن طه 41: 20) أي اصطفتيك لرسالتك. وقوله: (وَلْتَصْنَعْ عَلَيَّ عَيْنِي) (القرآن طه 20: 39) أي أنت بعيني إذ جعلتك أمك في التابوت، إشارة إلى ما قال بعض الحكماء: (إن الله تعالى إذا أحب عبداً تفقده كما يتفقد الصديق صديقه). (قاموس المعاني، 2010).

في كتاب (قصتي) لصاحب السمو الشيخ محمد بن راشد آل مكتوم، نائب رئيس دولة الإمارات العربية المتحدة، رئيس مجلس الوزراء، حاكم دبي، ورد في الوصية التاسعة ضمن الوصايا العشر للقائد المهلم: (اصنع قادة). ونصت الوصية على أنه: "صنع القيادات سر لا يفهمه إلا رجال تغلبوا على تضخم الأنا والذات، وفهموا أن أعظم إنجاز يصنعه هو بناء البشر وليس الحجر" (آل مكتوم، 2018). وفي مقولة لسومه في وسم #علمتي الحياة، عبر حسابها على تويتر: "الإرث الحقيقي لأي قائد في أية مؤسسة هو صناعة الرجال". وقد أطلق سمومه مبادرة "صناع الأمل"، ككبير مبادرة عربية تهدف إلى ترسيخ قيم الخير والعطاء، وتعزيز الإيجابية والنفاؤل، وتحسين نوعية الحياة في المجتمعات المنكوبة، وصناعة الفرق في حياة الناس من خلال القصص الملهمة الصادقة والمؤثرة التي يقدمها صناع الأمل في محيطهم المجتمعي. كما أشار العديد من الكتاب والباحثين إلى إن مفهوم صناعة الرجال مرادفاً إلى بناء عقول نيرة تواجه تحديات العصر وتصل المهارات للارتقاء بجودة الحياة. وأنه يمكن للفرد من صناعة ذاته، وإن ذلك ليس ضرباً من المستحيل كما ذكره كل من أرودا وديكسون في كتابهما استراتيجيات صناعة التميز الشخصي والمؤسسي، حيث أشار الكتابان إلى أن صناعة الذات تحتاج إلى استراتيجيات فهم أغوار النفس والمحيط، لا عتاق مذهب التفرد، وقد وضع أبع مبادئ لتلك الاستراتيجية تتمحور حول: الصمود من أجل الوصول، إدارة الذات، اغتنام فترات التطور الوظيفي، تسويق الذات (أرودا وديكسون، 2018). وأشار جون ماكسويل في كتابه (تطوير القائد بداخلك) إلى مبدأ: أن القادة لا يولدون، بينما يصنعون (Maxwell, 2019). وورد في كتاب (القيادة الأخلاقية وبناء قادة الصف الثاني في المنظمات العربية) أن النظرة الحديثة للقيادة أنها تصنع أكثر مما هي تولد، فهي مهارة وقدرة يمكن تعلمها واكتسابها بالتدريب والتنمية الذاتية، وبالتالي فإن المنظمات المتعلمة تعمل على صناعة قياداتها (حسنين، 2019). وبذلك يمكن تعريف صناعة التميز: أنها حرفة أو ملكة يختص بها البعض في الإلهام وتوجيه الآخرين وتمكينهم لإطلاق قدراتهم الكامنة وبلوغ التميز، والصناعة إحدى سمات القائد الذي يتغلب على الأنا والذاتية في التعامل مع المرؤوسين.

3.2 جوائز التميز الوظيفي في القطاع الحكومي بدولة الإمارات العربية المتحدة

أدت التطورات المتلاحقة التي عقيبت الثورة الصناعية الرابعة وظهور التكنولوجيا والنظم الإدارية والتقنية الحديثة، إلى تغييرات جذرية في نمط إدارة الأعمال في القطاعين العام والخاص. حيث تعددت طبيعة العمل وتشعبت الأدوار المنوطة بالمؤسسات وأصبح أرباب الأعمال غير قادرين على مواجهة التحديات دون التركيز على مواهب وقدرات الموارد البشرية وإشراكهم في اتخاذ القرارات الحاسمة. وبذلك توجه اهتمام القيادات وأرباب العمل بالتركيز على العنصر البشري لضمان استمرارية نجاح المنظمات. فعملت مؤسسات القطاع الحكومي على تعزيز القدرات البشرية ورصد الممارسات المتميزة وتكريمها من خلال طرح مبادرات التكريم والتقدير ومنح جوائز وأوسمة وشارات التميز للموظفين المتميزين. تعد دولة الإمارات العربية المتحدة من الدول السبقة في طرح الجوائز في القطاع الحكومي، وقدمدت خلال المدة الزمنية من 1995 إلى 2020م نماذج منوعة ومميزة من برامج وجوائز التميز الوظيفي. ويشير مصطلح جائزة إلى منحة مادية أو عينية، تمنح للموظف المتميز نظير عمل متقن تفرد به عن زملاءه، وتمنح الجائزة فرداً أو مع مجموعة من الزملاء. وهي تمثل تقدير رفيع المستوى يضيف شرفاً إلى سيرة الموظف ويؤهله إلى وضع مهني أفضل (سلمان م، 2006). وتلجأ الحكومات المتقدمة والمؤسسات والشركات الرائدة لأسلوب دعم وتقدير الموظفين بمنحهم جائزة تشجيعية تقريراً لتفردهم في الأداء ومساهماتهم في رفع الانتاجية المؤسسية. وقد تميزت فترة التسعينيات من القرن العشرين باهتمام دولة الإمارات العربية المتحدة في الكوادر الوطنية باعتبارها رأس المال البشري لإدارة شؤون الهيئات والمؤسسات الحكومية بكفاءة وفاعلية، والقوى المحركة للتميز المؤسسي في الدولة. فعملت الحكومة الاتحادية والمحلية على تعزيز الأداء الوظيفي في القطاع الحكومي بطرح مبادرات التمكين والتحفيز ووضع استراتيجيات وسياسات تطوير وتنمية الكوادر الوطنية والاهتمام برأس المال البشري واستثمار القدرات، من أمثلة برامج والجوائز التميز:

1983م: جائزة راشد بن حميد للثقافة والعلوم، 1998م: برنامج دبي للتميز الحكومي - جائزة دبي للاداء الحكومي المتميز، 1995م: جائزة الشارقة للثقافة والتميز التربوي، 1998م: جائزة حمدان بن راشد آل مكتوم للاداء التعليمي المتميز، 2009م: جائزة محمد بن راشد للاداء الحكومي المتميز ضمن برنامج الشيخ خليفة للتميز الحكومي، 2007م: برنامج عجمان للتميز الحكومي، 2009م: جائزة أبوظبي للتميز الحكومي، 2007م: جائزة خليفة التربوية، 2004م: برنامج الشيخ صفر للتميز الحكومي - جائزة فائق التميز في القطاع الحكومي.

2.4 القيادة الملهمة

وفقاً لما توصل إليه الباحثون و علماء النفس والمختصين في العلوم الإدارية، فإن القيادة عملية تأثير تستند على التكاملية بين أوار القائد لتشكل أفضل نمط قيادي، فلا يمكن أن ينجح القائد بالتركيز على نمط محدد وأسلوب واحد للعمل، ولكن لا يختلف الباحثون في أن سمات محددة وخصائص معينة تجعل من قائد ما فذاً عن الآخرين. كما أنه في التوجهات الحديثة في القيادة الإدارية للنمط القيادي الأفضل؛ هناك تركيز على القادة البار عون الذي يمتلكون المروءة وسين بقدرتهم على رفع الروح المعنوية لديهم، وحفزهم على النجاح من خلال استثارة مواهبهم وقدراتهم الكامنة والظاهرة، بالتكاملية في الأنماط القيادية من التشاورية والتبادلية والتحويلية والموقفية والأبوية والديمقراطية....، وإن هذا المزيج من النمط القيادي يمكن أن يطلق عليه بالقائد الملهم. أو بالأحرى فإن القيادة الملهمة سمة ملازمة للقادة البار عون.

برز المصطلح القادة الملهمة في الثمانينات وتوسع انتشاره في نهاية القرن العشرين، ويعني قدرة القائد على إلهام أتباعه نحو تحقيق رؤية المنظمة باستثارة مواهبهم وقدراتهم. يراه العديد من الباحثين نمط قيادي لأصحاب الهمم العالية والمبدعين من البشر الذين لا يعرفون للمستحيل طريقاً. فهم يمتلكون البصيرة النافذة والحكمة السديدة في تسيير الأمور. والقيادة الملهمة تعد من الممارسات الإيجابية ذات الأثر العالي على رضا العاملين فيها مما يحقق نجاحاً لاستراتيجية المؤسسة، حيث تعتمد على تعزيز العادات السلوكية للأفراد وحفزهم نحو العمل والاداء المتقن وتشجيعهم لبذل المزيد من العطاء بتوجيه مشاعرهم نحو قيم الانتماء والولاء المؤسسي. كما تمثل القيادة الملهمة نمط أو سلوك يختص به القائد الاستثنائي الذي يمتلك تأثيراً ذاتياً بالدجة الأولى؛ لتحويل المرؤوسين من حوله إلى أتباع راغبين في قيادته بطواعية، باستثارة مواهبهم وتعزيز القدرات الكامنة والظاهرة وتحفيزهم على النجاح الشخصي والمهني، ومهمة القائد الملهم الاستثنائي هي إلهام المرؤوسين والقيام بالعمل بطريقة مختلفة (سرحان، 2018؛ كوزيس و بوسنر، 2018؛ بيندليتون و أندراين، 2019).

ويرى بعض الباحثين أن في القيادة الملهمة توجه ديني وإن أكثر القيادات الملهمة هي الشخصيات الدينية. وأجمع أغلب الباحثين أنه توجه ذو سمة إيجابية، يدفع بالقائد إلى صناعة المعجزات البشرية بتحويلها من عناصر خاملة إلى عناصر فاعلة ومنتجة في المجتمع المهني. غير أن بعض الباحثين وجدوا أن القائد الملهم قد يكون ذا توجه سلبي أو إيجابي، حيث إن قدرته على استثارة العقول قد تتجه نحو الشر والتخريب كما تتجه نحو الخير والإعمار. ويضرب الباحثين الأمثلة على قيادات ملهمة على مر العصور والأزمنة، بثت الحيوية في الآخرين وانتقلت بهم إلى أداء مدهل وأفعال خارقة، سواء أكانت سلبية أو إيجابية، غيرت العالم نحو الخير والشر. ومن أمثلة القيادات الحكيمة الخيرة عبر التاريخ: قائد الأمة الإسلامية وختم الأنبياء محمد صلى الله عليه وسلم، والأنبياء السابقون، عليهم السلام، والخلفاء الراشدين،... وغيرهم. ومن الأمثلة العالمية قيادات إيجابية غيرت إطار الحياة مثل: أنيشتاين و نابليون و نابارد و جون سي ماكسويل وستيف جوبز..... وغيرهم (Adir, 2002) وفي العصر الحديث أمثلة على قيادات عربية، مثل: القائد جمال عبد الناصر، والشيخ زايد بن سلطان آل نهيان والشيخ محمد بن راشد آل مكتوم،... إلخ. كما هناك قادة ملهمين أغرقوا الأرض بدماء الشعوب البريئة، مثل: هولوكو، وجنكيز خان وهتلر،... إلخ. فهم قادة ملهمون أيضاً ولهم أهدافهم وطموحاتهم ولكنها اتجهت نحو المصلحة الشخصية والعنصرية والعدوانية (الجلبي، 2017؛ كول، 2014).

أمودج الإمارات للقيادة الحكومية يمثل أمودج الإمارات للقيادة الحكومية الجيل الثاني يعد إطلاق أمودج قائد القرن 21 الذي أطلقه صاحب السمو الشيخ محمد بن راشد آل مكتوم في عام 2015 (رسم توضيحي: 2.8) وتم تحديثه وتطويره في 2018م. ويتضمن الأمودج المحدث (3) محاور رئيسة تشمل سمات القائد الملهم في حكومة دولة الإمارات، وتمثل في: الروح القيادية، والنظرة المستقبلية، والإنجاز والتأثير. يهدف الأمودج إلى تعزيز جهود حكومة دولة الإمارات لمواكبة التوجهات العالمية في العمل الحكومي واستباق المتغيرات المستقبلية وقد طور الأمودج وفق توجهات الحكومة الرشيدة بعد الاطلاع على أفضل الممارسات العالمية في القيادة الإدارية، وخارطة الثورة الصناعية الرابعة للمساهمة في تحقيق أهداف رؤية الإمارات 2021، ومئوية الإمارات 2071، والاستعداد للشمسية للاحتفال باليوبيل الذهبي لقيام الاتحاد، والتي تشكل خارطة واضحة للعمل الحكومي الطويل المدى لتعزيز سمعة الدول (وزارة شؤون مجلس الوزراء والمستقبل، 2019).

أبعاد القيادة الملهمة في أمودج الإمارات للقيادة الحكومية: تمثل أبعاد القيادة في أمودج الإمارات للقيادة الحكومية ممارسات القائد الملهم الفذ، وتتضمن الأبعاد كافة ممارسات التعامل في إطار الموارد البشرية، (رسم توضيحي: 2.9) يمكن توضيحها على النحو الآتي (برنامج قيادات حكومة الإمارات، 2019):
بُعد الروح القيادية: ويتفرع عنه ثلاثة محاور: القائد مُمكن للإنسان، والقائد قُدوة حسنة، والقائد مفتوح على العالم
بُعد النظرة المستقبلية: ويتفرع عنه أربعة محاور: القائد الحكومي مستشرف للمستقبل، القائد الحكومي مبتكر ومحفز للتغيير القائد الحكومي ملم بتكنولوجيا المستقبل المتقدمة، والقائد الحكومي متعلم باستمرار ومدى الحياة.

بُعد الإنجاز والتأثير: ويتفرع عنه ثلاثة محاور: القائد الحكومي يركز على الغايات العليا للحكومة، القائد الحكومي يصنع قرارات ذكية وفعالة، والقائد الحكومي مرن وسريع الاستجابة.

2.5 دافعية الإنجاز وتحقيق الذات

منذ بزوغ الاهتمام بالقيادة الإدارية ومفاهيم الإدارة الفعالة؛ ونظريات الباحثين ودراساتهم تتجه نحو تفسير سلوك الإنسان وسمته الشخصية، والوصول إلى أهم العوامل المؤثرة في نجاح القيادة الإدارية وزيادة إنتاجية العمل في المنظمات. فما بين الاهتمام بنظريات القيادة الإدارية الحديثة، ونظريات القيادة الكلاسيكية، وأنماط القيادة الفعالة وسمات القائد الملهم، برز الاهتمام بالمرؤوسين وأثر دوافعهم الذاتية ورغباتهم الفردية في نجاح المنظمات وزيادة الإنتاجية المؤسسية. حيث استحوذت مفاهيم الدافعية الذاتية ودافعية الإنجاز اهتمام علماء النفس والباحثين لما لها من تأثير شامل على دفع الفرد نحو تحقيق أهداف محددة بشغف وهمة أكبر من المتوقع عند غياب الدوافع الذاتية. إلا أن الاهتمام بالدافعية ليس وليد العصر وبقضايا القيادة الإدارية، حيث وُجد عند الفلاسفة اليونان في القرون الأولى، وعلماء النفس الأوائل، ولهُ من أقدم الآراء حول الإنسان ودراسات الشخصية البشرية، والسلوك التنظيمي للأفراد في المؤسسات، باعتبار الإنسان كائن عاقل له رغبات يسعى إلى إشباعها بما يسمى الغريزة، وأن للعقل البشري ملكات توجه سلوكه وهي مسؤولة عن أفعاله التي تسمى بالإرادة.



تعتبر الدافعية من مفاهيم علم النفس السلوكي التي يمكن ملاحظتها من خلال أنشطة وممارسات الأفراد ضمن البيئة التي يعيشون فيها. تأتي الدوافع كاستجابة لحاجات بيولوجية تنتج من داخل جسم الإنسان كالحاجة للأكل والشرب والنوم، أو استجابة لحاجات اجتماعية تنتج من تفاعل الإنسان مع مجتمعه ومحيطه. فهي حالة فسيولوجية نفسية داخلية، حيث يولد المولود ولديه حاجات فطرية متعددة، وحاجات مكتسبة يتعلمها في الحياة، ترتبط بالمحافظة على بقائه في الحياة وبمستوى تكييفه بالبيئة المحيطة، ورغبته في التفوق والنجاح. وتعمل هذه الحاجات على تحريك الفرد للقيام بسلوك محدد في اتجاه محدد لتحقيق هدف محدد، يقاس على أساسه مستوى طموح الفرد، وإذ لم يتحقق الهدف يشعر الإنسان بنوع من العجز والضييق. ويرى الباحثين أنه بقدر ما تكون لدى الفرد دوافع وبواعث نفسية؛ بقدر ما يكون حماسه أكثر وطاقته أكبر وإدراكه أفضل. بينما يشير مفهوم التعزيز والحفز أو البواعث إلى مشيرات خارجية تجعل الفرد قادراً ومستعداً للقيام بعمل ما بمستوى أكبر من الهمة. والحوافز تنمي الدافعية، وتعمل على أكبر استثارة للطاقة لدى الموظفين، وتشير إلى استجابة لنيل رضا الآخرين. (المصري و عامر، 2014؛ أبو حليم، 2018؛ الشرفي، 2018؛ حسنين، 2019). كما عرفت الحوافز أنها مولدات النشاط والفاعلية في العمل، وتمثل أبرز الطرق للحصول على أفضل ما لدى الآخرين، فالمحفز خارجياً يثار وينشط من خلال الإدراك والوعي لما يريده الآخرين منه، وهو يسعى لإرضائهم (الروبي، 2005). وبالتالي تساعد على تحريك الدافع الداخلي للحصول على حالة الإشباع، وتختلف الحوافز الخارجية عن الأجر والراتب، فالأخير يمثل ما يتقاضاه الموظف نظير أداء منتظم ضمن إطار العمل (رشيد، 2016).

إن أول من أشار إلى مصطلح دافعية الإنجاز هو عالم النفس الأمريكي موراي، ومن ثم طورها ماكيلاند (انظر ص: 21). حيث يرى ماكيلاند أن الدوافع تستنثر من توقعات رسمها العقل، ووضع لها أهدافاً، تنفذ من خلال ممارسات سلوكية، فالإنسان يسعى نحو تحقيق الأهداف التي سبق له أن عرف أنها تثير لذة لديه. وبالتالي تعتبر: " كل الدوافع متعلمة فالاستثارة الوجدانية فطرية، ولكن التوقع مكتسب. وبهذا الشكل يبدو أنه من الممكن تحويل مفهوم اللذة إلى نظرية عملية مفيدة (موراي، 1988، ص 23). وقد توصل في تجاربه المتكررة إلى أن الدوافع متعلمة تعود إلى جملة الخبرات المكتسبة أثناء نمو الفرد في محيط أسرته وتفاعله مع أفراد المجتمع، وأن الأشخاص يتحفرون ذاتياً من خلال ثلاثة احتياجات رئيسية: احتياج الإنجاز، والنمو، والاندماج، وأن هناك أفراد حريصون على إتمام مهام العمل بأفضل صورة ومتحمسون في الأداء، بخلاف زملائهم غم تواجدهم تحت بيئة عمل مشتركة وظروف مهنية متساوية، وقد أطلق عليهم ذوي الإنجاز العالي (ماكجراث و بابتس، 2019).

عرف ماكيلاند دافعية الإنجاز أنها: "مظهر من مظاهر تطور الدوافع الغريزية وبمثابة الدليل على تعديل السلوك وتحسينه، فالحاجة للإنجاز تبرز الطاقة الكامنة للنجاح والتفوق، وزيادة معدل الإنتاج وحسن إدارة الأعمال وزيارة معدل الإنتاج وإحساس الفرد بالنجاح والتفوق في مجال عمله" (الرابعي، 2015، صفحة 156). وهي: "حالة داخلية أو خارجية تحت الفرد نحو الوصول إلى هدف معين" (أبو جودة، 2019، صفحة 47). ووردت لدى منصور زاهي تعريف كل من ماريو وليام وروبرت، أنها "حالة حافز فكري ونفسي، والذي يؤدي إلى إقرار صارم للحركة أو للقيام بشيء ما، وهذا يؤدي إلى بذل جهد عضلي وفكري للوصول إلى الأهداف المرجوة" وتعريف مرعي وأحمد أنها "قوة ذاتية تحرك سلوك الفرد وتوجهه لتحقيق غاية معينة، فيشعر بالحاجة الذاتية إليها أو باهبتها المادية والمعنوية" (زاهي، 2007، صفحة 63). وعرفها أتكسون أنها: "استعداد الكائن الحي لبذل أقصى جهد لديه من أجل تحقيق هدف معين" وعرفها روبيس أنها: "العمليات التي تحدد مدى كثافة أو اتجاه أو إصرار مجهود ما يبذله الفرد لتحقيق هدف معين". وعرفها غراي: أنها المدى الذي يمكن أن يصل إليه الجهد المنطوي على إصرار ومثابرة عند توجيهه نحو هدف معين". ويرى هامبتون أنها: "مجموعة القوى المنشطة والمحركة التي تأتي من داخل أو خارج الفرد بحيث تدفعه لانتهاج سلوك معين". وعرفها ماسلو أنها: "خاصية ثابتة ومستمرة، ومتغيرة، ومركبة وعامة تمارس تأثيراً في كل أحوال الكائن الحي" (خليفة، 2000، صفحة 69).

السمات الشخصية لذوي دوافع الإنجاز المرتفعة: مما توصلت إليه الباحثون سمات حول دافعية الإنجاز إلى أن أصحاب الدوافع العالية يتميزون بسمات تبدو مشتركة بين أغلبهم، كما اجتمع الباحثون على أن الدافعية سمة من سمات الموهوبين والتميز في الأداء، حيث يعملون بحماس ذاتي لتحقيق أهدافهم، أو لقليل من الدعم الخارجي لمواصلة العمل وإنجازه. وقد تكون السمات مورثة أو مكتسبة (كافي، 2018، صفحة 56؛ عبدالله م، 2000، صفحة 288؛ الروبي، 2005، صفحة 99) فدوى الدوافع العالية يتسمون ب:

الحماس والمثابرة: من أبرز ما يميز أصحاب الدوافع المرتفعة أنهم يتمتعون بالحماس والمثابرة في إنجاز المهام الموكلة، ويمكن أن يلحظ الآخرون حماسهم من خطواتهم ونظراتهم إلى ما يدور حولهم.

التحدي والتغلب على الصعاب: يبدون تحدياً في العمل، ويميلون إلى ممارسة الأنشطة التي تتسم بالمخاطرة ولا يهابون النتائج. الثقة بالنفس والاعتزاز بالذات: لديهم قدر عالي من الثقة بالنفس والاعتزاز بمهاراتهم وقدراتهم بناء على النتائج المحققة لديهم الالتزام وضبط النفس: غالباً ما يتميز ذوي الدوافع المرتفعة بالالتزام تجاه الآخرين وتجاه الأعمال وينجزون المهمات في الأوقات المحددة ولديهم القدرة على ضبط النفس في المواقف

التفوق والتفرد في الأداء: ذوي الدوافع المرتفعة لديهم روح التنافس يسعون إلى التفوق عن الأقران وإلى التفرد في أداء المهام الوظيفية. التخطيط: يخططون للمرحلة المقبلة في حياتهم الشخصية والمهنية، ويتوقعون النتائج بناء على الثقة بالذات المتابعة: يطلبون التغذية الراجعة مباشرة بعد إنجاز أعمالهم، ويحسون متابعة الأداء وتحسينه تحمل المسؤولية: لديهم القدرة على تحمل مسؤولية تحقيق أهدافهم والإشراف على إنجازات فرق العمل بمستويات من المسؤولية تجاهها

2 المحور الثالث: الاطار العملي: المنهجية والإجراءات

3.1 مجتمع الدراسة والعينة:

يشكل مجتمع الدراسة جميع الموظفين الفائزين بجوائز التميز الوظيفي في المؤسسات والوزارات الحكومية الاتحادية بدولة الإمارات العربية المتحدة منذ العام 1995م إلى العام 2020م وفق الجوائز المعتمدة في الدولة، والمحددة في الجدول: (3.1) جدول (3.1): مجتمع الدراسة يتكون من مجموع الفائزين في جوائز التميز الوظيفي

م	اسم البرنامج/ الجائزة	سنة التأسيس	رقم الدورة في العام 2020	الفئات المعنية	اجمالي الفائزين
1	جائزة الشارقة للتفوق والتميز التربوي	1995م	26	فئة الموظف الإداري/ المعلم/الموجه/ الاختصاصي الاجتماعي/ أمين مصادر التعلم/ مدير النطاق...	250
2	جائزة دبي للأداء الحكومي المتميز	1997	23	أوسمة الموظف المتميز في دبي	220
3	جائزة حمدان بن راشد للأداء الحكومي المتميز	1998م	22	فئة الموظف الإداري/التربوي المبادر/ المعلم/ الموجه/ الاختصاصي الاجتماعي/...	200

180	أوسمة التميز الوظيفي (8)	16	2004	جائزة صقر للتميز الحكومي/ جائزة التميز الحكومي	4
35	أوسمة رئيس المجلس التنفيذي (12 وسام)	6	2006	جائزة أبوظبي للأداء الحكومي المتميز	5
140	فئة المعلم المبدع/ المعلم التقني../	13	2007	جائزة خليفة التربوية	6
38	وسام رئيس مجلس الوزراء (15 وسام)	5	2009م	جائزة محمد بن راشد للأداء الحكومي المتميز	7
1063	-	-	-	الاجمالي	

وتكونت عينة الدراسة من (35%) من مجتمع الدراسة حيث مثلت (372) من مجموع المجتمع الأصلي (1063) تم اختيارهم بالطريقة التطبيقية، بمراعاة التنوع في حجم البرنامج/ الجائزة من حيث عدد الموظفين الفائزين بجوائز التميز الوظيفي في مؤسسات القطاع الحكومي في دولة الإمارات العربية المتحدة وذلك لتحديد نسبة مشاركة متجانسة للموظفين المتميزين في كل برنامج/ جائزة تميز، وضمان تمثيل عادل ومتساوي للعينة من جميع الجوائز.

3.2 أداة جمع البيانات:

لتحقيق أهداف الدراسة قام الباحث بتصميم أداة الدراسة المتمثلة في (الاستبانة) بعد الاطلاع على الأدبيات ذات العلاقة والدراسات في القيادة الملهمة، دافعية الإنجاز وتحقيق الذات، أدوار إدارات الجوائز وأثرها على تحقيق التميز الوظيفي. وقد تم صياغة الاستبانة بصورته الأولية من جزئين على النحو الآتي:

الجزء الأول: المعلومات العامة: وتمثلت العوامل الديموغرافية المؤثرة، والمذكورة ضمن سمات وخصائص عينة الدراسة (الجهة المانحة للجائزة/ الفئة الوظيفية/ المستوى التعليمي/ سنوات الخبرة/ الجنس).

الجزء الثاني: يتضمن (4) مجالات رئيسية تعبر عن متغيرات الدراسة، تتفرع عنها (10) محاور و(50) عبارة كما يوضح في الجدول: (3.2) جدول (3.2): هيكل توزيع المتغيرات الفرعية ومفردات العبارات مع توضيح المصدر

نوع المتغير	نطاق المتغير	المتغير	عدد العبارات	مصدر العبارات
المتغير غير المتساوي	القيادة الملهمة	الروح القيادية	5	أنموذج الإمارات للقيادة الحكومية (2018) أبعاد القيادة التحولية لباس وأفيليو (1985)
		النظرة المستقبالية	5	
		الإنجاز والتأثير	5	
المتغير المتساوي	ممارسات الموظف المتميز	الأداء والإنجاز	5	معايير الموظف المتميز المعتمدة في منظومة التميز الحكومي (2009) و المؤسسة الأوروبية للجودة الشاملة (1988)
		المبادرة والابتكار	5	
		التعلم المستمر	5	
المتغير غير المتساوي	دافعية الإنجاز وتحقيق الذات	دوافع داخلية	5	أبعاد الدوافع الداخلية والخارجية في نظرية دافعية الإنجاز لموراي وماكيلاند والنظرية السلوكية لثورندايك https://ar.wikipedia.org/wiki/31_%D8%A3%D8%BA%D8%B3%D8%B7%D8%B3
		دوافع خارجية	5	
المتغير غير المتساوي	جوائز التميز الوظيفي	أدوار إدارات الجوائز	5	عبارات من الخبرة المهنية للباحثة التي امتدت نحو عشرين عاماً في مجال التميز
		ملائمة معايير التميز	5	

هذا وصيغت جميع عبارات الاستبانة صياغة إيجابية، باختبار الدرجة (1) لاستجابة المبحوثين "غير موافق بشدة"، وأعطى لكل فقرة الوزن النسبي (20%) مدرجاً على مقياس ليكرت (Likert) الخماسي لتقدير درجة أهمية العبارة وفقاً لاستجابة المبحوثين لفقرات الاستبانة على النحو الآتي، جدول (3.3):

جدول (3.3): مقياس ليكرت الخماسي لتقدير درجة أهمية عبارات الاستبانة

الاستجابة	غير موافق بشدة	غير موافق	محايد	موافق	موافق بشدة
الدرجة	1	2	3	4	5

3.3 اختبار الصدق والثبات أ- اختبار الصدق:

أولاً: صدق المحتوى (Content Validity): تم عرض مسودة أداة القياس على مجموعة من المحكمين من الأساتذة في الجامعات الإماراتية الحكومية والخاصة (جامعة الإمارات، جامعة الشارقة، جامعة عجمان، جامعة حمدان بن محمد الذكية) وأساتذة من جامعات خارج الدولة (جامعة الملك عبدالعزيز وجامعة الإمام سعود بن محمد) من ذوي الخبرة في إدارة الموارد البشرية وإدارة السلوك التنظيمي والقيادة والتطوير المؤسسي وإدارة الأعمال والجودة والتميز الوظيفي والتربوي لإبداء آراءهم في صلاحيتها بهدف التحقق من الصدق الظاهري للأداة، وسلامة الصياغة اللغوية، واتمّاء الفقرات للمبدأ الذي درجت تحته. وأي مقترحات يراها المحكم من شأنها أن تثرى أداة الدراسة. وفي ضوء اقتراحات المحكمين وملاحظاتهم، تم تعديل فقرات الاستبانة من ناحية الصياغة لزيادة الوضوح، وحذف ما يلزم إن وجد التشابه ومقاربة المدلول. باعتبار آراء المحكمين وتعديلاتهم دلالة على صدق محتوى أداة الدراسة وملاءمة فقراتها وتنوعها.

ثانياً: الصدق البنائي (Construct Validity): ستقوم الباحثة بذلك من خلال التحليل العاملي التوكيدي (Confirmatory Factor Analysis) لجميع الاستبيانات الذي يستخدم في الحالات التي تكون فيها العلاقات بين المتغيرات والعوامل الكامنة معروفة، إذ ينطلق من افتراض معلوم يريد التحقق منه، وتحديد مدى مطابقة النموذج النظري للبيانات الميدانية المستمدة من العينة. حيث يتم استخراج مؤشرات حسن المطابقة ومعياري التقييم لهذه المؤشرات وذلك كما حدده (Hair et al., 2010) والممثل بالجدول (3.4):

جدول (3.4): مؤشرات المطابقة

معياري القبول	رمزه	المؤشر
Less than 3	CNIN/DF	مربع كاي النسبي
0.90	GFI	مؤشر حسن المطابقة
0.90	TLI	مؤشر توكر-لويس
0.90	CFI	مؤشر المطابقة المقارن
0.90	NFI	مؤشر المطابقة المعياري
0.08	RMSEA	مؤشر الجذر التربيعي لمتوسط خطأ الاقتراب
0.08	RMR	جذر متوسط مربعات البواقي

ب- اختبار الثبات: ستقوم الباحثة من التأكيد من ثبات أداة الدراسة من خلال استخراج معاملات الثبات ألفا كرونباخ (Alpha Cronbach) للاتساق الداخلي للفقرات، حيث من المفترض أن تتجاوز قيم معاملات ألفا كرونباخ عن (0.70) كما أشار إليه (Hair et al., 2010).

3.4 الدراسة الاستطلاعية

لأجل التحقق من عمق وجذور مشكلة الدراسة وطبيعة العلاقة بين متغيراتها، قامت الباحثة خلال مايو ويونيو ويوليو 2019م بطرح استطلاعات رأي حول أثر وأدوار القيادات تجاه تحفيز وتقدير جهود الموظفين المتميزين في الجهات الحكومية، وقام الباحث بطرح ثلاث أشكال من الاستطلاع لضمان تنوع فكر ومستويات المشاركين، وذلك على النحو الآتي:

الاستطلاع الأول: أجرى الباحث مقابلات شخصية مع المختصين في مجال التميز الوظيفي ومجال برامج تطوير القيادات الحكومية شملت إدارتي جائزة خليفة التربوية وجائزة حمدان بن راشد آل مكتوم وإدارة جائزة الإمارات للموارد البشرية الحكومية خلال مايو، يونيو، ويوليو 2019م.

الاستطلاع الثاني: صمم الباحث استطلاعاً بعدد من الأسئلة أطلقها عبر منصة "جوجل" الإلكترونية لصد انطباعات موظفي القطاع الحكومي من فئة الفائزين في الجوائز معتمداً على الأسئلة المفتوحة. شارك فيه (38) موظفاً من الجهات الحكومية من فئة الحاصلين على جوائز التميز الوظيفي، وذلك خلال يوليو 2019م، واستمر على مدى (14) يوماً.

الاستطلاع الثالث: قام الباحث بتصميم استطلاع رأي إلكتروني لموظفي القطاع الحكومي بشكل عام، عبر تطبيق (قصة) في قناة التواصل الاجتماعي (@excellence_mjsta) وذلك في 10 يوليو 2019م. شارك فيه (53) شخصاً بمستويات ثقافية عامة، وجاءت النتائج أن نسبة (60%) يرون أن القائد دور في دعم وتحفيز الموظفين للمشاركة في جوائز التميز، وأن نسبة (77%) يرون أن التحفيز الذاتي لدى الموظفين أكثر تأثيراً من التحفيز الخارجي.

3.5 المعالجة الإحصائية

ستقوم الباحثة باستخدام مجموعة من الأساليب الإحصائية الوصفية والتطليلية وذلك من خلال استخدام برنامجي (AMOS22) وبرنامج الحزمة الإحصائية (SPSS) حيث ستعتمد الباحثة على مقاييس الإحصاء الوصفي (التكرارات، المتوسطات الحسابية، الانحرافات المعيارية) إضافة إلى معامل الالتواء والتقلطح لمعرفة فيما إذا كانت البيانات تتوزع توزيعاً طبيعياً من عدمه. كما ستقوم الباحثة باستخدام التحليل العاملي التوكيدي للتأكد من صدق الأداة، وتحليل الانحدار (Regression Analysis) لفحص العلاقة المباشرة بين المتغيرات، وستقوم الباحثة باعتبار مستوى الدلالة عند ($P < 0.05$)

المراجع

القرآن الكريم الحديث والسنة المراجع العربية

ابن منظور، محمد المصري الأفريقي. (1986). لسان العرب- المجلد العاشر 2010. بيروت: دار صادر.
إحسان الأغا، و محمود الأستاذ. (2003). مقدمة في تصميم البحث التربوي. غزة: فلسطين: الرنتيسي للطباعة والنشر
أحمد أبورحمة. (2017). أثر عوامل البيئة الداخلية للمنظمة على مستوى دافعية الإنجاز لدى العاملين في قطاع الخدمات بوكالة الغوث الولية (الأونروا). رسالة ماجستير غير منشورة - قسم إدارة الأعمال - كلية التجارة. الجامعة الإسلامية بغزة.

- أحمد الشحي. (2019). *إدارة المواد البشرية والأداء في القطاع الحكومي بين الحاضر والمستقبل*. الإمارات: دبي: JustCreative.
- أحمد حسنين. (2019). *القيادة الأخلاقية وبناء قادة الصف الثاني بالمنظمات العربية*. الأردن: عمان: دار اليازوري العلمية للنشر والتوزيع.
- أحمد غنيم. (2009). *فعاليات الإدارة بين حداثة الاتجاهات وأفضل الممارسات*. جمهورية مصر العربية: المنصورة: المكتبة العصرية.
- أم سميت. (2016). *تروة الأمم (الجزء الأول)*. (وليد شحادة، المترجمون) دمشق: سوريا: دار فرقة للطباعة والنشر والتوزيع.
- إدوارد ج. موراي. (2017). *الدافعية والإنفعال*. (أحمد عبدالعزيز سلامة، المترجمون) دولة الكويت: مكتبة الفلاح للنشر والتوزيع.
- أشرف أحمد أبو حليمة. (2018). *دافعية الإنجاز*. عمان-الأردن: دار المهوية للنشر والتوزيع.
- أشرفي ف. (2019). *ماكينة الأفكار مدونة شخصية*. Retrieved 07 05, 2019, from <https://www.makinatalafkar.com/2019/04/WhatsInspiration.html>
- الرضى الفراج. (2016). *قياس أثر معايير التميز على نتائج الأداء في هيئة الطيران المدني السوداني*. أطروحة مقدمة لنيل درجة دكتوراه الفلسفة في إدارة الجودة والامتياز. السودان: جامعة السودان للعلوم والتكنولوجيا- كلية الدراسات العليا.
- النصيرات، أ. ع. (2018, 06 26). *مفهوم التميز*. إدارة. Retrieved 02 02, 2020, from <https://edara.com/Article/details/5235>
- آمال كركود. (2016). *الدوافع وأثرها على أداء العاملين في المكتبات الجامعية*. مجلة العلوم الإنسانية والاجتماعية بتبسة: الجزائر.
- إيهاب عيسى المصري، و طارق عبدالرؤف عامر. (2014). *السلوك التنظيمي وسلوك المنظمة*. القاهرة: المؤسسة العربية للعلوم والثقافة.
- بحر، يوسف عبدعطية. (2010). *علاقة القيادة التحولية بالإبداع الإداري لدى رؤساء الأقسام الأكاديميين*. رسالة ماجستير - كلية إدارة الأعمال- إدارة الموارد البشرية. فلسطين: الجامعة الإسلامية بغزة.
- بسام سمير الرميدي. (2019). *أثر تطبيق نمطي القيادة الموزعة والقيادة الملهمة على التهمك التنظيمي: دراسة تطبيقية على شركات السياحة المصرية*. بوابة الباحث- مجلة اقتصاد المال والأعمال المجلد (03) العدد (01) مارس 2019، 340-354.
- بلال خلف السكرانه. (2019). *القيادة الإدارية الفعالة*. عمان: الأردن: المسيرة للنشر والتوزيع والطباعة.
- بيتر ف. دراكر. (2011). *أساسيات بيتر دراكر*. بيروت: مكتبة لبنان ناشرون.
- ج. أ. كول. (2014). *الإدارة في النظرية والتطبيق*. سوريا: دار الفرقة للطباعة والنشر والتوزيع.
- جبران مسعود. (1992). *معجم الرائد (المجلد الطبعة السابعة)*. القاهرة: دار العلم للملايين.
- جون كراسيل. (2018). *تصميم البحوث الكمية والنوعية والمزجية*. (عبدالمحسن القحطاني، المترجمون) الكويت.
- جيرجن أيبيلو. (2017). *القيادة لتحقيق السعادة- أدوات وممارسات تحفيز فرق العمل*. تأليف مجموعة من الكتاب، *عقيرة القيادة وسعادة الآخرين*. الإمارات: دبي: دار قنديل للطباعة والنشر والتوزيع.
- جيفري تشو، مارتين ريفز، مايكل شاناهان، و روزليندا تورس. (2016). *القيادة الملهمة واستشراف المستقبل*. مجلة صدى الموارد البشرية، الصفحات 43-46.
- جيمس كوزيس، و باري بوسنر. (2018). *تحديات القيادة*. مكتبة جرير .
- جيمس ماكجراث، و بوب باينتس. (2019). *الكتاب الصغير لنظريات الإدارة الكبيرة وكيفية استخدامها*. مكتبة جرير .
- حسام حسن. (2011). *إدارة المواد البشرية في القطاع العام*. عمان: دار البداية ناشرون وموزعون.
- حسن بوزناق. (2020). *التسيير الحديث للكفاءات في المؤسسة كمدخل لتحقيق الميزة التنافسية - دراسة حالة المجمع الصناعي بصيدال*. أطروحة لنيل درجة الدكتوراه في علوم التسيير- تخصص الاقتصاد التطبيقي وإدارة المنظمات. الجزائر: جامعة باتنة الحاج لخضر.
- خالد بن محمد الرايغي. (2015). *عادات العقل ودافعية الإنجاز*. مركز دبيونو لتعليم التفكير.
- خبراء مركز الخبرات المهنية للإدارة. (2014). *الدافعية وحوافز العمل*. القاهرة: edarabook.com.
- خليفة الشرقى. (2018). *تأثير ممارسات إدارة الموارد البشرية على التميز المؤسسي في وزارة الداخلية بمملكة البحرين*. الأكاديمية الملكية للشرطة- كلية تدريب الضباط - قسم الدراسات العليا.
- خولة بلحوق. (2019, 06 24). *أثر القائد الملهم على الموظف المتميز*.
- خولة عبدالعال. (2016). *درجة توافر سمات القيادة التحولية لدى مديري المدارس الثانوية بمحافظة غزة وعلاقتها بمستوى الانتماء المهني لمعلميها*. رسالة لنيل درجة الماجستير في أصول التربية- إدارة تربوية: غير منشور. الجامعة الإسلامية: غزة.
- داود رن. (2019). *مفاهيم الإنجاز المختلفة ضمن سلسلة باحث وبحث*. Retrieved 02 20, 2019, from <http://kenanaonline.com/users/Nagydaoud/posts/563857>
- دلال الجرايدة، و نهاية الجازية. (2015). *دور جائزة الملكة رانيا العبدالله للمعلم المتميز في تحسين الأداء التعليمي للمعلمين في مديرية البلدية الشمالية الغربية*. مجلة المنارة للبحوث والدراسات، المجلد (21)، العدد (4).
- دي كامب. (2000). *مدير القرن 21*. المملكة العربية السعودية: الرياض: مكتبة الشفوي.
- ديفيد بيندليتون، و فورنهام أدراين. (2019). *كل ما ترغب معرفته عن القيادة*. (عصم سيد، المترجمون) القاهرة- مصر: المجموعة العربية للترتيب والنشر.
- رافع عقيل الزغلول، خلدون إبراهيم الدباي، و عبدالسلام هاني عبدالرحمن. (2019). *نظريات الشخصية*. عمان- الأردن: دار المسيرة للنشر والتوزيع والطباعة.
- زينب بوهنة، و مريم بالهادي. (2014). *إدارة الموارد البشرية في المؤسسات الاقتصادية*. الجزائر: وزارة التعليم العالي والبحث العلمي.
- ستيفن آر. كوفي. (2014). *القيادة المركزة على المبادئ*. المملكة العربية السعودية: مكتبة جرير .
- سلطان أحمد خليف، و وزيرة يحي محمد. (2012). *القيادة الملهمة والمفاجأة الاستراتيجية*. مجلة دورية نصف سنوية تصدر عن كلية الإدارة والاقتصاد- جامعة البصرة.
- سلطان خليف، و وزيرة محمد. (2014). *القيادة الملهمة والمفاجأة الاستراتيجية- دراسة استطلاعية لأراء عينة من القيادات الإدارية في عدد من دوائر محافظة نينوى*. مجلة دورية نصف سنوية تصدر عن كلية الإدارة والقيادة- جامعة البصرة- المجلد السابع- العدد الثالث عشر.
- سلوى تيباني. (2019). *القيادة الإدارية وعلاقتها بالأداء الوظيفي لدى عمال مديرية الشغال العمومية بالمسيلة*. رسالة ماجستير غير منشورة- كلية العلوم الإنسانية والاجتماعية - تخصص الموارد البشرية. جامعة محمد بوضياف بالمسيلة.
- سليمان الدروبي. (2005). *التفخيز عن طريق إبراز الذات*. الأردن: عمان: دار عالم الثقافة.
- سليمان عبدالله سرحان. (2018). *القيادة الملهمة والأزمات*. الأردن: دار وائل للنشر والتوزيع.

- سمر أكرم، و عاطف يوسف. (2014). درجة ممارسة مديري المدارس الثانوية الخاصة للقيادة التحولية وعلاقتها بدافعية المعلمين نحو عملهم. *دراسات، العلوم التربوية، المجلد (41)، ملحق (1) لسنة 2014.*
- سمير كامل محمود اللوح. (2017). دور القيادة الملهمه في تعزيز الالتزام التنظيمي بوزارة الأشغال العامة والاسكان- فلسطين. *رسالة لنيل درجة الماجستير في القيادة والإدارة - غير منشورة . جامعة الأقصى.*
- سيد الهواري. (1980). *التنظيم الهيكلي والسوكيات والنظم.* القاهرة: مكتبة عين شمس .
- سيد الهواري. (1982). *الإدارة الأصور والأسس العلمية.* القاهرة: مكتبة عين شمس.
- سيد الهواري. (2014). *القائد التحولي وتغيير المستقبل.* السعودية: الرياض: دار قرطبة للنشر والتوزيع.
- سيمون سينيك. (2016). *القادة يؤثرون فيؤثرون (القيادة فن التأثير في الآخرين).* الإمارات: دبي: دار قنديل للطباعة والنشر والتوزيع.
- شانتال بيرنز. (2018). *التحفيز الفوري- الحقيقة المدهشة وراء ما يحفز الأداء الأفضل.* مكتبة جرير.
- شذى عطاء. (2017). أثر القيادة الإستراتيجية والمعرفة في تحقيق تميز الأداء بشركات الاتصالات السودانية. *رسالة دكتوراه غير منشورة- مقامة للحصول على درجة دكتوراه الفلسفة في إدارة الأعمال.* جامعة السودان للعلوم والتكنولوجيا .
- صياحي الأخضر. (2018). دور القيادة التحولية في تحقيق التميز التنظيمي بالمؤسسة الاقتصادية. *أطروحة دكتوراه في علوم التيسير.* الجزائر: جامعة محمد بوضياف بالمسيلة.
- عبد الستار إبراهيم، و رضوى إبراهيم. (2003). *علم النفس أسسه ومعالم دراساته.* السعودية: مطابع الدار الهندسية.
- عبد المعطي البحيسي. (2014). دور تمكين العاملين في تحقيق التميز المؤسسي. *دراسة ميدانية على الكميات التقنية في محافظات قطاع غزة - رسالة ماجستير في إدارة الأعمال.* فلسطين: جامعة الأزهر.
- عبد الحميد الخليل. (2018). إدارة الموارد البشرية منشورات الجامعة الافتراضية السورية.
- عبد الغفار حنفي. (2010). *السلوك التنظيمي وإدارة الموارد البشرية.* مصر: الإسكندرية: الدار الجامعية.
- عبد الغني أبو العزم. (2013). *معجم الغني الزاهر.* القاهرة: دار الغني للنشر والتوزيع.
- عبد الكريم بكار. (1431). *اكتشاف الذات دليل التميز الشخصي.* الرياض: المملكة العربية السعودية: دار وجوه للنشر والتوزيع.
- عبد اللطيف محمد خليفة. (2000). *الدافعية للإنجاز.* القاهرة: دار غريب للنشر والتوزيع.
- عبد الله بن سلطان. (2014). حوكمة التميز - جائزة وزير الداخلية للتميز أنموذجاً. *مجلة الفكر الشرطي- مركز بحوث الشرطة في القيادة العامة لشرطة الشارقة - المجلد (23) - العدد (88).*
- عبد الله سليمان. (2013). أثر جوائز الدولة للتميز في تطوير المنظمة - دراسة حالة شركة تاكسي دبي. *رسالة دكتوراه غير منشورة . السودان: جامعة أم درمان الإسلامية.*
- عبد المجيد النشواني. (1993). *علم النفس التربوي (الإصدار 6).* دار الفرقان- جامعة اليرموك: جامعة اليرموك- الأردن.
- علي الرشدي. (2018). القيادة التحولية وعلاقتها بالإبداع التنظيمي لدى عمداء ورؤساء الأقسام بالجامعات الحكومية والأهلية بمدينة الرياض. *المجلة العربية للدراسات الأمنية المجلد (33) العدد (71) الرياض 2018.* السعودية.
- علي السلمي. (2001). *إدارة الموارد البشرية.* القاهرة: دار غريب للطباعة والنشر والتوزيع.
- محمود الشنطي. (2016). أثر ممارسة أساليب القيادة التحولية في جودة الحياة الوظيفية دراسة تطبيقية على وزارة الصحة الفلسطينية. *المجلة الأردنية في إدارة الأعمال. المجلد 12 العدد 1 2016.* جامعة القدس المفتوحة.
- محمود العميان. (2018). *السلوك التنظيمي في منظمات الأعمال.* الأردن: دار وائل للنشر والتوزيع.
- محمود المساد. (2003). *الإدارة الفعالة.* بيروت- لبنان: مكتبة لبنان ناشرون.
- محمود سمير محمد الحلبي. (2017). دور القيادة الملهمه في توظيف مخرجات البحث العلمي في وزارة الداخلية والأمن الوطني الفلسطيني. *أطروحة للحصول على درجة الماجستير في القيادة والإدارة . أكاديمية الإدارة . والسياسة للدراسات العليا- مسار النخبة.*
- مختار نور الدين عثمان. (2014). *الإدارة والقيادة التربوية.* الكويت: دار حنين للنشر والتوزيع.
- مدحت أبو النصر. (2015). *قادة المستقبل: القيادة المتميزة الجديدة.* مدينة نصر: القاهرة : المجموعة العربية للتدريب والنشر.
- عماد طوال. (2017). *القائد الملهم.* تاريخ الاسترداد 12 26 2019، من زينبات- العالم من روما: <https://ar.zenit.org/articles>
- فاضل، علي رمضان. (2013). *جمهورية أفلاطون.* القاهرة: دار طيبة - الجيزة.
- فواز مالح العنزي. (2015). القيادة الملهمه كمدخل لتطوير الأداء وتحقيق التميز المدرسي. *Bloomsbury Qatar Foundation.* قطر: مؤتمر التعليم 2015 «شركاء التميز».
- فيصل خربشي. (2019). فعالية الأداء الوظيفي لإدارة الموارد البشرية ودوره في تحقيق الأداء المتميز للأفراد في المؤسسة الرياضية. *رسالة ماجستير غير منشورة . الجزائر : جامعة محمد بوضياف بالمسيلة.*
- قابن حسين. (2017). النمط القيادي للمدراء وعلاقته بدافعية الانجاز لدى الطاقم الإداري في المركبات الرياضية - بولاية جيجل. *جامعة حمد بوضياف بالمسيلة . رسالة ماجستير غير منشورة - جامعة حمد بوضياف بالمسيلة.*
- قاسم علوان. (2005). *إدارة الجودة الشاملة .* بيروت: دار الثقافة للنشر والتوزيع.
- قانون الموارد البشرية في الحكومة الاتحادية. (أكتوبر، 2016). *الهيئة الاتحادية للموارد البشرية.*
- قيس محمد علي وليد سالم حموك. (2014). *الدافعية العقلية رؤية جديدة.* عمان الأردن: مركز دبيونو لتعليم التفكير .
- كلوس شواب. (2016). *الثورة الصناعية الرابعة.* جنيف: سويسرا: المنتدى الاقتصادي العالمي.
- لورانس أ. برافين. (2010). *عالم الشخصية، الجزء الأول.* (عبد الحليم محود السيد، ايمن محمد عامر، و يحي محمد الرخاوي، المترجمون) القاهرة: المركز القومي للترجمة.
- ماجد الخياط. (2017). العلاقة بين الإثراء الوظيفي والدافعية للعمل لدى العاملين في جامعة البلقاء التطبيقية: دراسة تطبيقية مسحية لموظفي مركز الجامعة. *مجلة جامعة النجاح للإبحاث للعلوم الإنسانية: الأردن - المجلد (31) العدد (08) 2017.*
- ماريا محمد، الشريف أسعد، و إدريس ناصر. (2017). دور الرضا الوظيفي في تحقيق دافعية الإنجاز لدى العاملين في وزارة المالية بولاية البحر الأحمر. *مجلة جامعة البحر الأحمر للعلوم الإنسانية - العدد (4) ديسمبر 2017.*
- ماهر محمد صالح حسن. (2004). *القيادة أساسيات ونظريات ومفاهيم.* الأردن: دار الكندي للطباعة والنشر.

- مجاهد رشيد. (2016). أثر دوافع العمل والتحفيز كوسيلة لتحقيق الرضا الوظيفي والأداء في المنظمة. *مجلة الاقتصاد التطبيقي والإحصاء المجلد (11) ، العدد (2) ، 99-114.*
- محمد التويجري، و محمد البرعي. (1993). *معجم المصطلحات الإدارية*. الرياض: المملكة العربية السعودية: مكتبة العبيكان.
- محمد الصيرفي. (2006). *القيادة الإدارية والإبداعية*. مصر- الاسكندرية: دار الفكر الجامعي.
- محمد بن راشد آل مكتوم. (2018). *قصتي*. الإمارات العربية المتحدة- دبي: إكسبلور للنشر والتوزيع.
- محمد زائري. (2007). *التميز في الأداء- دليل عملي*. (هاني وليم، المترجمون) الإمارات: دبي: مركز التعريب والنشر: الكلية الإلكترونية للجودة الشاملة.
- محمد قاسم القريوتي. (2013). *مقدمة في الإدارة العامة*. الكويت: مكتبة الفلاح للنشر والتوزيع.
- محمد قاسم عبدالله. (2000). *الشخصية والعلاج النفسي*. سوريا- دمشق: دار المكتبي للطباعة والنشر والتوزيع.
- مسكين عبدالله. (2015). *السلوك القيادي لدى المشرفين التربويين في التعامل مع المعلمين- دراسة استطلاعية للمشرفين في التربية والتعليم بمديرية التربية لولاية مستغانم. مخبر تطوير الممارسات النفسية والتربوية العدد (15)*. جامعة وهران: الجزائر.
- مصطفى يوسف كافي. (2018). *إدارة المواهب البشرية في المنظمات*. الجزائر: ألفا للوثائق نشر واستيراد وتوزيع الكتب.
- معجم لسان العرب لابن منظور. (بلا تاريخ). تاريخ الاسترداد 6 1 2020، من دفع: <http://wiki.dorar-aliraq.net/lisan-arab/%d8%af%d9%81%d8%b9>
- منال البارودي. (2016). *القائد المتميز وأسرار الإبداع القيادي*. القاهرة: المجموعة العربية للتدريب والنشر.
- منصور بن زاهي. (2007). *الشعور بالاعتراب الوظيفي وعلاقته بدافعية الإنجاز لدى الإطارات الوسطى لقطاع المحروقات. جامعة منتوري- قسنطينة -علم النفس وتسيير الموارد البشرية*. الجزائر.
- منصور بن زاهي. (2007). *الشعور بالاعتراب الوظيفي وعلاقته بدافعية الإنجاز لدى الإطارات الوسطى لقطاع المحروقات. جامعة منتوري- قسنطينة -علم النفس وتسيير الموارد البشرية*. الجزائر.
- منصور بن زاهي. (2007). *الشعور بالاعتراب الوظيفي وعلاقته بدافعية الإنجاز لدى الإطارات لقطاع المحروقات. جامعة منتوري الفلسطينية- كلية العلوم الإنسانية والاجتماعية*.
- منى جواد سلمان. (2018). *الحكومة في ضوء نماذج التميز المؤسسي*. الشارقة: مكتبة الجامعة.
- منى سلمان. (2006). *فنون التوثيق ومهاراته- دليل المتميزين في توثيق الأداء المهني المقدم للجوائز التربوية*. الإمارات: مكتبة دبي للتوزيع.
- ناجي الشريف. (2017). *الأداء الوظيفي لدى الموظفين الإداريين في جامعة نجران. المجلة الدولية التربوية المتخصصة- المجلد (6) العدد (8)*. العراق.
- نواف كنعان. (1995). *القيادة الإدارية*. عمان- الأردن: دار الثقافة للنشر والتوزيع.
- هانم العيسوي. (2019). *الإدارة التشاركية إدارة جيل الألفية*. جمهورية مصر العربية: الاسكندرية: مركز ليفانت للدراسات الثقافية والنشر.
- هشام بوكفوس. (2006). *أساليب تنمية الموارد البشرية في المؤسسة الاقتصادية العمومية الجزائرية. جامعة الإخوة منتوري. كلية العلوم الأنسبية والاجتماعية*.
- ويليام أرودا، و كرستين ديكسون. (2018). *استراتيجيات صناعة التميز الشخصي والمؤسسي*. (زكي القاضي، و محمد ابوضيف، المترجمون) جمهورية مصر العربية: مدينة نصر : المجموعة العربية للنشر والتوزيع.
- ياسر كداو. (2016). *إدارة الموارد البشرية بين النظرية والتطبيق*. دبي: دار الكتب.
- ياسين المحارمة. (2017). *مدى معرفة معلمي التربية الرياضية المشاركين بجائزة الملك عبد الله الثاني للياقة البدنية بمتطلبات الجودة الشاملة من وجهة نظر مديريهم. مجلة المنارة للبحوث والدراسات المجلد (23)، العدد (3)*. الأردن.
- يحي جاسر أبو جودة. (2019). *النكاه الاجتماعي ودافعية الإنجاز*. (عمان- الجامعة الأردنية، المحرر) المملكة الأردنية الهاشمية: دار زهدي للنشر والتوزيع.
- يوشيو كوندو. (2005). *التحفيز الإنساني عامل أساسي في الإدارة*. الإمارات: دبي: مركز التعريب والنشر بالكلية الإلكترونية للجودة الشاملة.

ثالثاً: المراجع الأجنبية

- Adair, J. (2002). *Inspiring Leadership - Learning from Great Leaders*. London: Thorogood Publishing Ltd.
- Apak, S., & Gümüş, S. (2015). A research about the effect of the leadership qualities of public administrators on the motivation of the employees. *Procedia-Social and Behavioral Sciences*, 210, 368-377.
- ALQA YDI, E. (2015). Investigating the Factors of the Police Force Culture that Influence the Maintenance of the EFQM Excellence Model within the United Arab Emirates. *Al-Fikr Al- Shurti- Volume (24) - Issue No (93)*.
- Basit, A., Sebastian, V., & Hassan, Z. (2017). IMPACT OF LEADERSHIP STYLE ON EMPLOYEE PERFORMANCE (ACASESTUDY ON A PRIVATE ORGANIZATION IN MALAYSIA). *International Journal of Accounting & Business Management -Vol. 5 (No.2), November, 2017*.
- Finney, L. (2019, 7 18). *What Is Inspirational Leadership?* Retrieved 12 26, 2019, from UNDERSCORE - Learning & Development: <https://www.underscore-group.com/learning-and-development/what-is-inspirational-leadership/>
- Folkman, J., & Zenger, J. (2015). The Inspiring Leader Unlocking the secret Behind How Extraordinary Leaders Motivate. *LEADERSHIP DEVELOPMENT*, 4,5.
- Fraenkel, J. R., & Wallen, N. E. (1993). *How to design and evaluate research in education*. Boston: MA McGraw Hill.
- Garton, E. (2017, 4 27). How to Be an Inspiring Leader. *Harvard Business Review*, pp. <https://hbr.org/2017/04/how-to-be-an-inspiring-leader>.
- GHUFLI, A. A. (2012). Implementation of Business Excellence Model: A Case Study of UAE Public Sector Organisation. *PhD in Business*. University of Manchester.

- Graves, L. M., & Sarkis, J. (2018). The role of employees' leadership perceptions, values, and motivation in employees' provenvironmental behaviors. *Journal of Cleaner Production*, 196, 576-587.
- Hair, J.F., Black, W.C., Babin, B.J., & Anderson, R.E. (2010). *Multivariate Data Analysis*.. Seventh Edition. Prentice Hall, Upper Saddle River, New Jersey
- Heathfield, S. M. (2019). *What Makes a Leader Inspirational?* Retrieved 12 26, 2019, from The balance careers: <https://www.thebalancecareers.com/leadership-inspiration-1918611>
- Hunt, J. G., & Larson, L. (1977). *Leadership: The cutting Edge*. Carbondale: Shouth ern Illinois University Ptes.
- Kanat-Maymon, Y., Elimelech, M., & Roth, G. (2020). Work motivations as antecedents and outcomes of leadership: Integrating self-determination theory and the full range leadership theory. *European Management Journal*.
- Leithwood, K. (1992). *The Move toward Transformational Leadership*. Retrieved 11 01, 2019, from Educational Leadership: http://www.ascd.org/ASCD/pdf/journals/ed_lead/el_199202_leithwood.pdf
- Levin, M. (2017, 3 23). *Why Great Leaders Inspire Instead of Motivate* . Retrieved 12 25, 2019, from Incmagazine: <https://www.inc.com/marissa-levin/why-great-leaders-like-richard-branson-inspire-instead-of-motivate.html>
- Lodgaard, E., Ingvaldsen, J. A., Aschehoug, S., & Gamme, I. (2016). Barriers to continuous improvement: perceptions of top managers, middle managers and workers. *Procedia CIRP*, 41, 1119-1124.
- Maxwell, J. C. (2019). *Developing the Leader within You 2.0*. jarir bookstore.
- Miller, M. (2019). *Inspirational Leadership that Strengthens Employee Creativity*. Retrieved 05 05, 2019, from Emergenetics International.: <https://www.emergenetics.com/blog/inspirational-leadership-strengthens-employee-creativity>
- Mitchell, R., & Boyle, B. (2019). Inspirational leadership, positive mood, and team innovation: A moderated mediation investigation into the pivotal role of professional salience. *Human Resource Management*, 58(3), 269-283.
- Murray, N. (2015, December 9). *7 Characteristics of Inspiring Leaders*. Retrieved December 25, 2019, from Entrepreneur Middel Ease: <https://www.entrepreneur.com/article/252916>
- Rassel Kassem, Ajmal, M., & Khan, M. (2016). The Relationship Between Organizational Culture and Business Excellence: Case Study from United Arab Emirates. *International Journal of Information Systems in the Service Sector*.
- Salas-Vallina, A., Simone, C., & Fernández-Guerrero, R. (2018). The human side of leadership: Inspirational leadership effects on follower characteristics and happiness at work (HAW). *Journal of Business Research*.
- Shafi, M., Lei, Z., Song, X., & Sarker, M. N. I. (2020). The effects of transformational leadership on employee creativity: Moderating role of intrinsic motivation. *Asia Pacific Management Review*.
- Sony, M. (2019). Implementing sustainable operational excellence in organizations: an integrative viewpoint. *Production & Manufacturing Research*, 7(1), 67-87.
- ربيعاً: مواقع الانترنت
أشرفي ف. (2019). *ماكينه الأفكار مدونه شخصية : ماهو الإلهام؟*. Retrieved 07 05, 2019, from <https://www.makinatalafkar.com/2019/04/WhatIsInspiration.html>
- Wahid, H., & Ahmad, S. (2009). Pengagihan Zakat Oleh Institusi Zakat Di Malaysia: Mengapa Masyarakat Islam Tidak Berpuas Hati? *Shariah Journal*, 17(1), 89-112.
- والتدريب الفني التعليم وزارة : صنعاء. □□□□□□□□ □□□□ □□□□□□□□ □□□□□□□□. للإحصاء العامة الإدارة اليمنى المهني.
- Abd Ghani, A., & Othman, Z. (2016). Kerangka Kerja Conceptual Pelaporan Kewangan Islam bagi Wakaf, Zakat dan Baitulmal di Malaysia. *Seminar Penyelidikan Perakaunan dan Pelaporan Kewangan Islam bagi Institusi Wakaf, Zakat dan Baitulmal di Malaysia* (p. 23). Putrajaya: Jabatan Akauntan Negara Malaysia.
- Abd. Rahman, A., & Anwar, S. (2013). Peranan Institusi Zakat Dalam Pembangunan Pendidikan Asnaf, Fakir dan Miskin di Malaysia. *5th Islamic Econimcs System Conference (IECONS 2013)*.
- Abdul Rahim, R. A., Ismail, P., & Mohd Dahlal, N. H. (2009). Ijtihad dalam Institusi Fatwa di Malaysia: Suatu Analisis. *Jurnal Syariah*, 215.
- Abdullah, M. A., & Chong, R. (2014). Financial Literacy: An Exploratory Review of the Literature and Future Research. *Journal of Emerging Economies and Islamic Research Vol.2 No.3*, 1-9.
- AbdulLatif, L. (2012). *The Problem Faced by a State in the Collection of Zakat (Tax)*. Master Thesis, University of Nairobi.
- Abral, E., Anwar, & Harianto, S. (2016, Nov-Dec). Design Of accounting Information System For zakat In Amil Zakat Institution In Lhokseumawe City. *IOSR Journal of Computer Engineering (IOSR-JCE)*, 18(6), 25-37.
- Adair, J. (2002). *Inspiring Leadership - Learning from Great Leaders*. London: Thorogood Publishing Ltd.
- Adina-Petruța. (2012). The Importance of Quality in Higher Education in an Increasingly Knowledge-Driven Society. *International Journal of Academic Research in Accounting, Finance and Management Sciences*,

120-127.

- Adisaputro, M. R. (2018, Juni 21). *Semangat Literasi dalam Pandangan Islam*. Retrieved from Jamaah Salahuddin: <http://js.ugm.ac.id/2018/06/21/semangat-literasi-dalam-pandangan-islam/>
- Ahmad Satori Ismail, M. F. (2018). *Fikih Zakat Kontekstual Indonesia*. Jakarta: BAZNAS.
- Ahmad, M. Y., Mohamad, M., Muda, M., Jamsari, E., Wan Hassan, W., & Mohd Kashim, M. (2018). Confronting the Problem of Managing Unclaimed Inheritance Property of Muslims in Malaysia. *International Journal of Civil Engineering and Technology (IJCIET)*, 1459-1466.
- Ahmad, M., Palil, R., Abu Bakar, A., & Dollah, N. (2015). The Literature Review on the Knowledge of Islamic Banking Products among Muslim Entrepreneurs. *South East Asia Journal of Contemporary Business, Economics and Law*.
- Ahmad, M., Palil, R., Mohd Isa, M., & Dolah, N. (2015). Knowledge of Islamic Banking Products among Muslim Entrepreneurs: Proposed Theoretical Framework, Hypothesis Development, Research Design and Operational Definitions. *International Journal of Business, Economics and Law*.
- Aibak, K. (2015). Zakat Dalam Perspektif Maqashid Al-Syariah. *AHKAM*, 3(3), 199-218.
- Akhtar, M. I. (2016). Research Design. In *Research in Social Science: Interdisciplinary Perspectives*.
- Al Azraq, & Ahmad, H. (1980, January 1). Majallah al-Jamiah al-Islamiah bi al-Madinah al-Munawwarah. *Nizam al-Doro'ib fi al-Islam*, pp. 271-280.
- Al Haq, M., & Abdul Wahab, N. (2019, July). Effective Zakah Distribution: Highlighting Few Issues and Gaps in Kedah, Malaysia. *Al-Iqtishad: Journal of Islamic Economics*, 9(2), 259-288.
- Albers, M. J. (2017). Quantitative Data Analysis—In the Graduate Curriculum. *Journal of Technical Writing and Communication*, 47(2), 215–233.
- Al-Goaib, S. (2003). Religiosity and social conformity of university students: an analytical study applied at King Saoud University. *Arts Journal of King Saoud University*.
- Ali, M. F. (2015). Modern Application of Hibah in the Light of Shari'ah Objectives of Gift and Donation Contract (Al-Tabarru'at). *Islamic Science*, 13 (Summer 2015).
- Ali, I., & Hatta, Z. (2010). Zakat as a Poverty Reduction Mechanism Among the Muslim Community: Case Study of Bangladesh, Malaysia, and Indonesia. *Asian Social Work and Policy Review*, 8(2014), 59-70.
- Al-khalili, J. (2011). *The House of Wisdom: How Arabic Science Save Ancient Knowledge and Gave Us the Renaissance*. New York: Penguin Press.
- al-Khin, M., al-Bugho, M., & sy-Syarbaji, A. (2005). *Terjemahan Fiqh al-Manhaji; Kitab Feqah Mazhab Syafie*. Kuala Lumpur: Pustaka Salam.
- ALQA YDI, E. (2015). Investigating the Factors of the Police Force Culture that Influence the Maintenance of the EFQM Excellence Model within the United Arab Emirates. *Al-Fikr Al-Shurti- Volume (24) - Issue No (93)*.
- Alvi, M. (2016). A manual for selecting sampling techniques in research. *Munich Personal RePEc Archive*.
- al-Zaylai, J. a.-D. (2002). *Nasb al-Rayah Takhrij Ahadith al-Hidayah* (2 ed., Vol. 4). Beirut: Dar al-kutub al-Ilmiyyah.
- Al-Zuhayli, W. (2007). *Financial Transactions in Islamic Jurisprudence* (Vol. 1). Damascus: Dar al Fikr.
- Amiruddin, K. (2015). Pengelolaan Zakat di Dunia Muslim. *Ahkam*, 139-166.
- Ancori, B. (2016, May). Scientific popularization, increasing knowledge gap, and epistemology of communication. *Nouvelles perspectives en sciences sociales*, pp. 181–232.
- Antara, M. P., Musa, R., & Hassan, F. (2016). Bridging Islamic Financial Literacy and Halal Literacy: The Way Forward in Halal Ecosystem. *Procedia Economics and Finance* 37, 196-202.
- Apriyanto, D., & Harini, R. (2012). DAMPAK KEGIATAN PERTAMBANGAN BATUBARA TERHADAP KONDISI SOSIAL EKONOMI MASYARAKAT DI KELURAHAN LOA IPUH DARAT, TENGGARONG, KUTAIKARTANEGARA. *Jurnal Bumi Indonesia*, Vol. 1 No. 3, 290-300.
- Ascarya, & Yumanita, D. (2018). Analisis Rendahnya Penghimpunan Zakat di Indonesia dan Alternatif Solusinya. *Bank Indonesia Working Paper*.
- Ashley, C. d. (2000). Developing methodologies for livelihood impact assesment: Experience of the African Wildlife Foundation in East Africa. *ODI Working Paper 129, London: ODI*.
- Asri, A. N. (2019, Januari 28). Literasi dalam Al-Qur'an: Studi Komparatif Tafsir Ibnu 'Ashur dan Al-Baqa'i terhadap Surah Al-Alaq ayat 1-5. Surabaya, Jawa Timur, Indonesia: UIN Sunan Ampel.
- Assie'-Lumumba, N. T. (2005). Higher Education In Africa: Crises, Reforms and Transformation. *Senegal: Council for the Development of Social Science Research in Africa*.
- Azmi, F. A., & Sabit Mohammad, M. (2011). The Causes of Unclaimed, Late Claimed or Distrubuted Estates of Deceased Muslims in Malaysia. *International Conference on Sociality and Economic Developmet IPEDR*. Singapore.
- Azmi, S. (1995). *Abu Yusuf's Contribution To The Theory of Public Finance*. India: Aligarh Muslim University.
- Bagir, Z. A., & Abdullah, I. (2011). The Development and Role of Religious Studies: Some Indonesian Reflection. In K. Bustamam-Ahmad, & P. Jory, *Islamic studies and Islamic education in contemporary Southeast Asia* (pp. 57-74). Kuala Lumpur, Malaysia: Yayasan Ilmuwan.

- Bandura, A. (1989). Social cognitive theory . In R. Vasta, *Annals of child development: Six theories of child development* (pp. 1-60). Greenwich: JAI Press.
- Bank Negara Malaysia. (2014). *Annual Report 2014*. Kuala Lumpur: Bank Negara Malaysia.
- Basit, A., Sebastian, V., & Hassan, Z. (2017). IMPACT OF LEADERSHIP STYLE ON EMPLOYEE PERFORMANCE (ACASESTUDY ON A PRIVATE ORGANIZATION IN MALAYSIA). *International Journal of Accounting & Business Management -Vol. 5 (No.2), November, 2017*.
- Baunsgaard, T., & Keen, M. (2005). Tax Revenue and (or?) Trade Liberalization. *IMF Working Paper*, 05/112.
- BAZNAS. (2016). *Rencana Strategis Zakat Nasional 2016-2020*. Jakarta: Badan Amil Zakat Nasional.
- BAZNAS. (2018). *Perbaznas No.3 Tahun 2018 Tentang Pendistribusian dan Pendayagunaan*. Jakarta: BAZNAS.
- BAZNAS. (2018). *Zakat Outlook 2019*. Jakarta: Pusat Kajian Strategis BAZNAS.
- BBC, M. M. (2012). *Syrian opposition army imposes Islamic tax on Christians in Homs*. Homs: BBC Worldwide Limited.
- Bernard, H. R. (2002). *Research Methods in Anthropology: Qualitative and quantitative methods*. Walnut Creek, California: Altamira Press.
- Bhardwaj, A. (2016). Importance of Education in Human Life: a Holistic Approach. *International Journal of Science and Consciousness*, 23-28.
- Bhatt, G. D. (2000). Organizing Knowledge in The Knowledge Development Cycle . *Journal of Knowledge Mangament*, 15-26.
- Bidol, S. (2014). Pengaruh Tata kelola Terhadap Perolehan Zakat Bagi Kelangsungan Usaha Mustahiq di Sulawesi Selatan. *Jurnal PILAR*, 2(2), 1-52.
- Biggam, J. (2001). Defining Knowledge: an Epistemological Foundation for Knowledge Management. *Proceedings of the 34th Hawaii International Conference on System Sciences*, (pp. 1-7). Hawaii.
- Bireysel, D. E., & Etkileri, S. (2010). The Impacts of Religious Education on Individual and Social Life. *Dinbilimleri Akademik Araştırma Dergisi*, 195-211.
- BPS. (2018). *Produk Domestik Regional Bruto Provinsi-Provinsi di Indonesia Berdasarkan Lapangan Usaha*. Jakarta: Badan Pusat Statistik.
- BPS. (2018). *Statistik Indonesia 2018*. Jakarta: Badan Pusat Statistik.
- BPS. (2018). *Tingkat Ketimpangan Pengeluaran Penduduk Indonesia*. Jakarta: Badan Pusat Statistik.
- Buang, A. H. (2007). *Undang-undang Islam di Malaysia: Prinsip dan Amalan*. Kuala Lumpur: Universiti Malaya.
- Carter, B., & Levy, J. (2012). *Facebook Marketing 3rd Edition (Engels) - Leveraging Facebook's Features for Your Marketing Campaign*. United States of America: QUE: Indianapolis.
- Chalid Talib, I. I. (2007). Restrukturisasi Peternakan di Indonesia. *Analisis Kebijakan Pertanian*, 1-14.
- Chou, C.-M. (2014). Social Media Characteristics, Customer Relationship and Brand Equity. *Journal of Applied Business and Economics*, 16(1), 128-139.
- Christoff, Z. (2013). A Logic for Social Influence through Communication. *11th European Workshop on Multi-Agent Systems (EUMAS)*. Toulouse: Logical Aspects of Multi-Agent System (LAMAS).
- Cialdini, R. B., & Trost, M. (1998). Social influence: Social norms, conformity, and compliance. In D. T. Gilbert, S. Fiske, & G. Lindzey, *The handbook of social psychology* (pp. 151-192). Boston: McGraw-Hill.
- Clark, N. (2014). *World Education News & Reviews*. Retrieved March 28, 2019, from World Education News & Reviews: <https://wenr.wes.org/2014/12/education-in-malaysia>
- Clarke, F., Craig, R., & Hamid, S. (1996). Physical Asset Valuation and Zakat. *International Accounting*, 195-208.
- Coakes, S. J., & Steed, L. (2007). *SPSS Version 14.0 for Windows: Analysis Without Anguish* (1st ed.). Wrightbooks.
- Creswell, J. W. (2005). *Educational Research: Planning, Conducting and Evaluating Quantitative and Qualitative Research* (2nd ed.). Merrill Prentice Hall: Pearson.
- Devanport, T. H., De Long, D., & Beers, M. (1998). Successful Knowledge Management Projects. *MIT Sloan Management Review*, 39(2), 43-57.
- Diaz-Quijano, F. A., Martínez-Vega, R., Rodriguez-Morales, A., Rojas-Calero, R., Luna-González, M., & Díaz-Quijano, R. (2018). Association between the level of education and knowledge, attitudes and practices regarding dengue in the Caribbean region of Colombia. *BMC Public Health*, 143.
- Dillard, J. P., & Pfau, M. (2002). *The persuasion handbook: Developments in theory and practice*. SAGE Publications, Inc.
- Duarte, L. C. (September, 2016). Impact of Armed Education and Educational Agents: A Multivocal Review. *Educare Elec tronic Journal*, pp. 1-24.
- Elgaroshi, T. S., & Musa, A. S. (2013). Control of Income Tax Evasion in Islamic (Syariah) and Malaysian Law. *Australian Journal of Basic and Applied Science*, 770-780.
- Emami-Naeini, P., Degeling, M., Bauer, L., Chow, R., Cranor, L., Haghghat, M., & Patterson, H. (2018). The Influence of Friends and Experts on Privacy Decision Making in IoT Scenarios. *Proceedings of the ACM on Human-Computer Interaction*. New York: ACM.
- Embong, M., Taha, R., & Mohd Nor, M. (2013). Role of Zakat to Eradicate Poverty in Malaysia. *Jurnal Pengurusan*, 39, 141 - 150.

- Emran, S., & Stiglitz, J. (2005). On Selective Indirect Tax Reform in . *Journal of Public Economics*, 599-623.
- Encyclopedia Britannica. (retrieved 2016, September 19). *global.britannica.com*. Retrieved from Encyclopedia Britannica: <http://global.britannica.com>
- Encyclopedia Britannica. (retrieved 2016, September 19). *global.britannica.com*. Retrieved from Encyclopedia Britannica: <http://global.britannica.com>
- Fah, L. Y. (2009). Using Multiple Regression in Social Science Research: Some Important Aspects. *Jurnal Kinabalu, Universiti Malaysia Sabah*, 73-87.
- Fakta Terbaru Produksi Minyak Bumi Indonesia*. (30, Agustus 30). Retrieved from Kementerian Energi dan Sumber Daya Mineral Republik Indonesia: <https://www.esdm.go.id/id/media-center/arsip-berita/fakta-terbaru-produksi-minyak-bumi-indonesia>
- Farmayanti, T. G. (2011). Analisis Kelayakan Pengembangan Usaha Ternak Kambing Perah. *Forum Agribisnis*.
- Faryab, M. H. (2002). *The Status of Knowledge in Islam Translated by Fatemeh Soltanmohammadi*. Islamic Jurisprudence Encyclopedia Institute.
- Finney, L. (2019, 7 18). *What Is Inspirational Leadership?* Retrieved 12 26, 2019, from UNDERSCORE - Learning & Development: <https://www.underscore-group.com/learning-and-development/what-is-inspirational-leadership/>
- Folkman, J., & Zenger, J. (2015). The Inspiring Leader Unlocking the Secret Behind How Extraordinary Leaders Motivate. *LEADERSHIP DEVELOPMENT*, 4,5. Retrieved from <https://zengerfolkman.com>
- Fraenkel, J. R., & Wallen, N. E. (1993). *How to design and evaluate research in education*. Boston: MA McGraw Hill.
- Garton, E. (2017, 4 27). How to Be an Inspiring Leader. *Harvard Business Review*, pp. <https://hbr.org/2017/04/how-to-be-an-inspiring-leader>.
- Gemmell, N., & Morrissey, O. (2003). Tax Structure and the Incidence on . *Centre for Research in Economic Development and International Trade*, 03-18.
- Ghani, F. A., & Ahmad Razali, N. (2017). Legal Review on Hibah (Inter Vivos Gift) in Malaysia: Problem and Solution. *8th International Economics and Business Management Conference*. Future Academy.
- Ghuri, P. N., & Gronhaug, K. (2005). *Research Methods in Business Studies: A Practical Guide*. Harlow: FT: Prentice Hall.
- GHUFLI, A. A. (2012). Implementation of Business Excellence Model: A Case Study of UAE Public Sector Organisation. *PhD in Business*. University of Manchester.
- Gill, J., & Johnson, P. (2002). *Research Methods for Managers*. Thousand Oaks California: SAGE Publication Inc.
- Grant, C., & Osanloo, A. (2014). Understanding, Selecting, and Integrating a Theoretical Framework in Dissertation Research: Creating the Blueprint for 'House'. *Administrative Issues Journal: Connecting Education, Practice and Research*, 12-22.
- Grapragasem, S., Krishnan, A., & Mansor, A. (2014). Current Trends in Malaysian Higher Education and the Effect on Education Policy and Practice: An Overview. *International Journal of Higher Education*.
- Haji Ahmad, I., & Ma'in, M. (2014). The Efficiency of Zakat Collection and Distribution: Evidence from Two Stage Analysis. *Journal of Economic Cooperation and Development*, 35(3), 133-179.
- Hani, A. (2017, June 1). *The Malaysian Reserve*. Retrieved from The Malaysian Reserve: <https://themalaysianreserve.com/2017/06/01/kg-baru-development-still-stuck-on-ownership-issue/>
- Haron, N., Hassan, H., Jasni, N., & Rahman, R. (2010). Zakat for Asnaf's Business by Lembaga Zakat Selangor. *Malaysian Accounting Reviews*, 9(2), 123-138.
- Harun, T. W., Ab Rashid, R., & Hamed, A. (2015). Factors Influencing Products' Knowledge of Islamic Banking Employees. *Journal of Islamic Studies and Culture*, 23-33.
- Hasan, M. A. (2008). *Zakat dan Infak Salah Satu Solusi Mengatasi Problem Sosial di Indonesia*. Jakarta: Kencana Predana Media Grup.
- Hashim, R. (2006). *Educational Dualism in Malaysia: Implications for Theory and Practice*. Kuala Lumpur, Malaysia: Fajar Bakti.
- Hassan, R. (2003). *Faithlines: Muslim Conceptions of Islam and Society*. Oxford University Press.
- Heakal, R. (2016, October 19). *What is Fiscal Policy?* Retrieved from investopedia.com: <http://investopedia.com>
- Heathfield, S. M. (2019). *What Makes a Leader Inspirational?* Retrieved 12 26, 2019, from The balance careers: <https://www.thebalancecareers.com/leadership-inspiration-1918611>
- HsinChang, H., & ShiiChuang, S. (2011). Social capital and individual motivations on knowledge sharing: Participant involvement as a moderator. *Information & Management*, 48(1), 9-18.
- Huda, M., Yusuf, J., Jasmi, K., & Zakaria, G. (2016). Al-Zamūjī's Concept of Knowledge ('Ilm). *SAGE*, 1-13.
- Hunt, D. P. (2003). The concept of knowledge and how to measure it. *Journal of Intellectual Capital*, 100-113.
- Hunt, J. G., & Larson, L. (1977). *Leadership: The cutting Edge*. Carbondale: Southern Illinois University Pteess.
- Imran, M. K., Iqbal, S., Aslam, U., & Fatima, T. (2019). Does social media promote knowledge exchange? A qualitative insight. *Management Decision*, 57(3), 688-702.
- International Islamic University, M. (2016, September 3). *IUM Endowment Fund/Waqf*. Retrieved from IIUM Web

- Site: <http://iium.edu.my>
- International Youth Foundation. (2016). Retrieved 06 13, 2020, from <https://www.iyfnet.org/about-us/ar>
- Islahi, A. (2016). *Pondering over The Quran (Translated from Urdu Tadabbur-e-Quran)* (Vol. 1). (M. Kayani, Trans.) Kuala Lumpur, Malaysia: Islamic Book Trust.
- Ismail, I. A., & Hussein, M. N. (2017, March). Productive Zakat Distribution by Zakat Institutions in Malaysia. *International Journal of Academic Research in Business and Social Sciences*, 7(3), 554-565.
- Jabatan Kemajuan Islam Malaysia, J. (2015). *Indeks Syariah Malaysia Model Tadbir Urus Berteraskan Maqasid Syariah*. Kuala Lumpur: Jabatan Kemajuan Islam Malaysia.
- Johari, F., & Ibrahim, P. (2010). The Dynamism in the implementation of Al-Kharaj during the Islamic rule. *Shariah Journal*, 629-658.
- Jr, J. F., Black, W., Babin, B., & Anderson, R. (2014). *Multivariate Data Analysis*. Edinburgh Gate Harlow: Pearson Education Limited.
- Juanda, B. (2009). *Metode Penelitian Ekonomi dan Bisnis*. Bogor: IPB Press.
- Kahf, M. (2002). *Sustainable Development in the Muslim Countries*. Tehran: Shahid Beheshti University.
- Kaiser, H. F. (1960). The Application of Electronic Computers to Factor Analysis. *Educational and Psychological Measurement*, 141-151.
- Kamali, M. (2008). *Maqasid al-Shariah Made Simple*. London and Washington: The International Institute of Islamic Thought.
- Kaplan, A. M., & Haenlein, M. (2010). Users of the world, unite! The challenges and opportunities of Social Media. *Business Horizons*, 53(1), 59-68.
- Karimizadeh, N., & Abolghasemi, M. (2016). The Islamic and Religious Education in Malaysian Schools: From Past Up to Now. *International Academic Journal of Innovative Research*, 19-29.
- Kim, Y. J., & Hollingshead, A. (2015). Online Social Influence Past, Present, and Future. *Communication Year Book*.
- Laluddin, H., Mohammad, M., Mohd Kusrin, Z., Ahmad, S., Nasohah, Z., Muda, M., . . . Muhammad Husni, A. (2012). An analysis of maslahah's development through al-Ghazali pre and post al-Ghazali Periods. *International Business Management*, 187-193.
- Larson, M. G. (2006). Descriptive Statistics and Graphical Displays. *Statistical Primer for Cardiovascular Research*, 76-81.
- Leftheriotis, I., & N.Giannakos, M. (2014). Using social media for work: losing your time or improving your work? *Computers in Human Behaviour*, 134-142.
- Leithwood, K. (1992). *The Move toward Transformational Leadership*. Retrieved 11 01, 2019, from Educational Leadership: http://www.ascd.org/ASCD/pdf/journals/ed_lead/el_199202_leithwood.pdf
- Levi, D. (2014). Power and Social Influence. In *Group Dynamics for Teams* (pp. 127-145). San Luis Obispo, USA: SAGE Publications, Inc.
- Levin, M. (2017, 3 23). *Why Great Leaders Inspire Instead of Motivate*. Retrieved 12 25, 2019, from Inc magazine: <https://www.inc.com/marissa-levin/why-great-leaders-like-richard-branson-inspire-instead-of-motivate.html>
- Lietsala, K., & Sirkkunen, E. (2008). *Social Media: introduction to the tools and processes of participatory economy*. Tampere, Finland: University Press.
- Lubis, M., Yaacob, N., Omar, Y., & A. Dahlan, A. (2011). Enhancement of Zakat Distribution Management System Case Study in Malaysia. *Political Science*.
- Lusardi, Annamaria, & Mitchel, O. S. (2011). Financial Literacy and Retirement Planning in the United States. *Journal of Pension Economics and Finance* 10(4), 509-525.
- Malaysia, A. G. (2017). *Laporan Aktiviti 2017 Jabatan Akauntan Negara Malaysia*. Accountant General's Department of Malaysia.
- Malaysia, J. K. (n.d.). *Indeks Syariah Malaysia Model*.
- Malaysia, P. o. (2006). *Perbahasan Dewan Rakyat Kesebelas, Penggal Ketiga, Mesyuarat Pertama*. Kuala Lumpur: Parlimen Malaysia.
- Mandell, L., & Linda, S. K. (2009). The Impact of Financial Literacy Education on Subsequent Financial Behavior. *Journal of Financial Counseling and Planning Vol. 20, Issue 1*, 15-24.
- Marghinani, S. B. (2005). *The Hidayah, Commentary on the Islamic Law*. Karachi-Pakistan: Darul-Ishaat.
- Mastercard. (2016, 6 9). *Press Releases*. Retrieved from Mastercard Official Website: <https://newsroom.mastercard.com/asia-pacific/press-releases/singapore-tops-financial-literacy-index-in-asia-pacific/>
- Mauluddin, I. (2015, March 30). *Cukai dalam Islam: Kajian Perbandingan Menurut Yusuf Al-Qardhawi dan M. Umer Chapra*. Retrieved from The Way To Success: <http://ikhwanmauluddin.blogspot.my/2015/03/>
- Maxwell, J. C. (2019). *Developing the Leader within You 2.0*. jarir bookstore.
- Miller, M. (2019). *Inspirational Leadership that Strengthens Employee Creativity*. Retrieved 05 05, 2019, from Emergenetics International.: <https://www.emergenetics.com/blog/inspirational-leadership-strengthens>

- employee-creativity
- Moerad, S. K. (2011). IMPLEMENTASI DAN EVALUASI CORPORATE SOSIAL RESPONSIBILITY (CSR) DI PERUSAHAAN PENGEBORAN MINYAK PETROCINA KABUPATEN BOJONEGORO - JAWA TIMUR. *Jurnal Sosial Humaniora Volume 4*.
- Moghadam, S. R., Selamat, H., & Moosavi, S. (2013). Exploring the Key Factors of Knowledge Sharing via Employee Weblogs. *Research Journal of Applied Sciences, Engineering and Technology*, 6 (19), 3686-3694.
- Mohajan, H. (2017, October 1). Two Criteria for Good Measurements in Research: Validity and Reliability. *Munich Personal RePEc Archive (MPRA)*, 17(3), pp. 58-82. Retrieved from <https://mpra.ub.uni-muenchen.de/83458/>
- Mohammad, M. O., & Shahwan, S. (2013). The Objective of Islamic Economic and Islamic Banking in light of Maqasid Al-Shariah: Critical Review. *Middle East Journal of Scientific Research* 13, 75-84.
- Mokhtar, N., & Hassan, R. (2017). Judicial Remedies for Banks When a Customer Defaults Under Ijarah Muntahia Bi Al-Tamlik Home Financing Facility. *Malayan Law Journal Articles*.
- Muhamad, N. H., Kamarudin, M., Abdullah, A., Sholehuddin, N., Abdul Hamid, M., Muhidin, I., & Abdul Karim, K. (2019). Islamic Intervivos Law Challenges in Malaysia. *Journal of legal, Ethical and Regulatory Issues*.
- Murray, N. (2015, December 9). *7 Characteristics of Inspiring Leaders*. Retrieved December 25, 2019, from Entrepreneur Middle East: <https://www.entrepreneur.com/article/252916>
- Muslimaid.org. (2015, June 22). The Complete Zakat Guide. London, England.
- Nasrul, M. A., & Mohd Salim, W. (2018). Administration of estates in Malaysia: Determinant of factors behind the delay in the distribution of the deceased's asset. *Journal of Nusantara Studies*, 75-86.
- Netemeyer, R. G., Bearden, W., & Sharma, S. (2003). *Scaling Procedures. Issues and Applications*. London: SAGE Publication Ltd.
- OJK. (2017). *Strategi Nasional Literasi Keuangan Indonesia*. Jakarta: Otoritas Jasa Keuangan.
- Oruc, C. (2010). The Impacts of Religious Education on Individual and Social Life. *Dinbilimleri Akademik Araştırma Dergisi*, 195-211.
- Oxford Dictionary of Economics, 3. (2009, September 19). *Oxford Dictionaries*. doi:10.1093/acref/9780199237043.001.0001
- Oxford Dictionary of Economics, 3. (2009, September 19). *Oxford Dictionaries*. doi:10.1093/acref/9780199237043.001.0001
- Pallant, J. (2011). *A Step by Step Guide to Data Analysis Using the SPSS Program: Survival* (4th ed.). Berkshire: McGraw-Hill.
- Pemanfaatan Sumber Daya Mineral dan Pengelolaan Lingkungan*. (2009, June 20). Retrieved from Kementerian Energi dan Sumber Daya Mineral Republik Indonesia: <https://www.esdm.go.id/id/media-center/arsip-berita/pemanfaatan-sumber-daya-mineral-dan-pengelolaan-lingkungan>
- Pertanian, K. (2018). *Statistik Peternakan dan Kesehatan Hewan 2018/ Livestock and Animal Health Statistics 2018*. Jakarta: Pertanian, Kementerian.
- Prakoswa, R. H. (2018, Agustus 8). *Di Zaman Jokowi, Pertamina Perlahan Geser Asing di Migas*. Retrieved from CNBC Indonesia: <https://www.cnbcindonesia.com/news/20180808115645-4-27531/di-zaman-jokowi-pertamina-perlahan-geser-asing-di-migas>
- Pribadi, A. (11, January 2018). *Capaian Tahun 2017 dan Outlook 2018 Subsektor Mineral dan Batubara*. Retrieved from Kementerian Energi dan Sumber Daya Mineral Republik Indonesia: <https://www.esdm.go.id/id/media-center/arsip-berita/capaian-tahun-2017-dan-outlook-2018-subsektor-mineral-dan-batubara>
- Pribadi, A. (2019, January 10). *Tahun 2019, DMO Batubara 20-25 Persen*. Retrieved from Kementerian Energi dan Sumber Daya Mineral Republik Indonesia: <https://www.esdm.go.id/id/media-center/news-archives/tahun-2019-dmo-batubara-20-25-persen>
- Prime Minister's Office, P. R. (2015). *Teks Ucapan YAB Dato' Sri Mohd Najib bin Tun Haji Abd Razak Sempena Perasmian Indeks Syariah Malaysia*. Kuala Lumpur: Prime Minister's Office.
- Pulungan, D. R. (2017). Literasi Keuangan dan Dampaknya Terhadap Perilaku Keuangan Masyarakat Kota Medan. *Jurnal Ilmu Ekonomi dan Studi Pembangunan Vol.17 No.1*, 56-61.
- PUSKAS. (2019). *Dampak Zakat Terhadap Tingkat Kesejahteraan Mustahik: Studi Kasus Lembaga-Lembaga Program BAZNAS*. Jakarta: Pusat Kajian Strategis BAZNAS.
- Qardhawi, Y. (n.d.).
- Qardhawi, Y. (1973). *Fiqh Zaka>t: Dira> satu Muqa> ranatu al-Ah}ka> miha> wafalsafatuha> fi> d}aijfil Qura>n was Sunnah*. Beirut: Ar-risalah Foundation.
- Qomar, A. M. (2015). Arah Baru Kebijakan Publik: Studi Kasus Pembedayaan Zakat. *Jurnal Bimas Islam*, 8(IV).
- Rassel Kassem, Ajmal, M., & Khan, M. (2016). The Relationship Between Organizational Culture and Business Excellence: Case Study from United Arab Emirates. *International Journal of Information Systems in the Service Sector*.

- Razak, Y. D. (2016). Prime Minister's Speech In Conjunction With Launching of Malaysian Index Syariah Implementation Plan 2016-2018. *Department of Islamic Development Malaysia* (pp. 1-21). Putrajaya: Prime Minister Office.
- Risal, S., Paranoan, D., & Djaja, S. (2013). Analisis Dampak Kebijakan Pertambangan Terhadap Kehidupan Sosial Ekonomi Masyarakat di Kelurahan Makroman. *Jurnal Administrative Reform, Vol.1 No.3*, 512-528.
- Rosli, M., Salamon, H., Nur Muhamad, N., Zulkifli, A., & Sayed Ahmad, S. (2017). Modification of Zakat Distribution Management for Muslim Community Well-Being. *International Journal of Academic Research in Business and Social Sciences*, 7(12).
- Rosman, A. S., Mohd Yusof, F., Abu, F., & Syed Abdullah, S. N. (2015). Cukai Barang dan Perkhidmatan (GST) Berdasarkan Perspektif Fiqh Kontemporari. *Bengkel Penyediaan Soal Jawab GST Menurut Perspektif Islam* (pp. 1-39). Felda Residence, Kuala Terengganu: Jawatankuasa Fatwa Majlis Kebangsaan.
- Rosman, A. S., Mohd Yusof, F., Abu, F., & Syed Abdullah, S. N. (2015). Cukai Barang dan Perkhidmatan (GST) Berdasarkan Perspektif Fiqh Kontemporari. *Bengkel Penyediaan Soal Jawab GST Menurut Perspektif Islam* (pp. 1-39). Felda Residence, Kuala Terengganu: Jawatankuasa Fatwa Majlis Kebangsaan.
- Salleh, M. (2006). Lokalisasi Zakat: Suatu Cadangan Teoritis. In I. Abdul Ghafar, & H. Muji Tahir, *Zakat: Penseyarian Ekonomi dan Perundangan* (pp. 213-227). Bangi: Universiti Kebangsaan Malaysia.
- Samsudin, N. A. (2010). *Rahsia pemasaran facebook* (4th ed.). Seri Kembangan Selangor: Truewealth.
- Sarwono, B. (2008). *Beternak Kambing Unggul*. Jakarta: Penebar Swadaya.
- Saunders, M., Lewis, P., & Thornhill, A. (2009). *Research methods for business students*. Edinburgh Gate Harlow: Pearson Education Limited.
- SEADI, DEFINIT & OJK. (2013). *Developing Indonesian Financial Literacy Index*. Jakarta: DEFINIT Asia.
- Sekaran, U., & Bougie, R. (2016). *Research Method for Business: A Skill Building Approach* (7th ed.). Chichester, West Sussex, United Kingdom: John Wiley & Sons Ltd.
- Setiadi, M. R. (2016). Peran Amil Zakat dalam Mengoptimalkan Zakat Produktif : Studi Analisis Badan Amil Zakat Daerah (BAZDA) Kota Bekasi. *Maslahah*, 7(1), 49-70.
- Shaban, M. A. (1976). *Islamic History: A New Interpretation*. Cambridge: Cambridge University Press.
- Shabrina, G., Lestari, L. A., Iqbal, B. M., & Syai, D. H. (2019). Redesign of User Interface Zakat Mobile Smartphone Application with User Experience Approach. *1st International Conference on Industrial and Manufacturing Engineering*. IOP Publishing.
- Shafie, F., Wan Yusoff, W., & Dawilah El Edrus, S. (2016). Factors of Failure and Delay in Islamic Inheritance Distribution in Malaysia. *Jurnal Teknologi (Science & Engineering)*.
- Shinkafi, A. A., & Ali, N. A. (2017). Contemporary Islamic Economic Studies on Maqasid Shari'ah: a systematic literature review. *Humanomics, Vol. 33*, 315-334.
- Simon, M. K., & Goes, J. (2011). Correlational Research. *Dissertation and Scholarly Research: Recipes for Success*. Seattle, WA.
- Sintha Dwi Wulansari, A. H. (2014). Analisis Peranan Dana Zakat Produktif Terhadap Perkembangan Usaha Mikro Mustahik (Penerima Zakat). *Diponegoro Journal of Economics, Volume 3* (Nomor 1), 1-15.
- Sreenivasulu, S. E. (2013). Role and Importance of Educational for Effective Growth of Indian Economy: An Overview. *IOSR Journal Of Humanities And Social Science (IOSR-JHSS)*, 32-35.
- Star, T. (2016, February 3). *Star Online*. Retrieved from Star Online: <https://www.thestar.com.my/metro/community/2016/02/03/estates-worth-rm60bil-left-unclaimed/>
- Suharto, R. B., Hilmawan, R., & Yuzaruddin, R. (2015). SUMBER DAYA ALAM UNTUK KESEJAHTERAAN PENDUDUK LOKAL: Studi Analisis Dampak Pertambangan Batu Bara Di Empat Kecamatan Area Kalimantan Timur, Indonesia. *Jurnal Organisasi dan Manajemen, Vol.11, No.2*, 127-137.
- Sunhaji, M. (2016). The Implementation of Integrated Learning in the Islamic Religion Education as to Grow the Religiosity and Faith of Learners. *International Journal of Humanities and Social Science*, 6(11), 279-289.
- Supi, S. S. (2018, December 2018). *Utusan Malaysia*. Retrieved from Utusan Malaysia: <http://www.utusan.com.my/rencana/utama/elak-pergaduhan-harta-pusaka-1.806499>
- Syalabi, H. A., & Al-'Aliy, K. S. (2015). *Mukhtashar Shahih Al-Bukhari*. Darul Haq.
- Syaltut, M. (2004). *Al-Fatawa. Prt. 18*. Beirut: Dar Al-Syuruq.
- Syukur, F. (2018). *Sejarah Peradaban Islam 2*. Semarang: IAIN Walisongo.
- Tahir-ul-Qadri, M. (2007). *Islamic Concept of Knowledge*. Lahore, Pakistan: Minhaj-ul-Quran Publications.
- Tahir-ul-Qadri, S.-u.-I. D. (2007). *Islamic Concept of Knowledge*. Lahore Pakistan: Minhaj-ul-Qur an Publications.
- Takril, N., Othman, N., Ahmad Sanusi, S., & Tajuddin, T. (2018). The Efficient of Zakat Counters Collection and Distribution in Higher Learning Institution. *5th International Research Management and Innovation Conference (IRMC 2018)*. Putra Jaya, Malaysia.
- Terbaik dalam Pelaksanaan CSR, Pertamina EP Raih The Best Indonesia Green Award 2019*. (2019, March 28). Retrieved from Dunia Energi: <https://www.dunia-energi.com/terbaik-dalam-pelaksanaan-csr-pertamina-ep-raih-the-best-indonesia-green-award-2019/>
- Tika Widiastuti, S. R. (2015). Model Pendayagunaan Zakat Produktif oleh Lembaga Zakat dalam Meningkatkan

- Pendapatan Mustahiq. *Jebis*, 1(1), 89-102.
- Today, F. M. (2017, July 31). *Free Malaysia Today*. Retrieved from Free Malaysia Today: <https://www.freemalaysiatoday.com/category/bahasa/2017/07/31/amanah-roya-rm315-juta-harta-tidak-dituntut-pewaris/>
- UNDP. (2017). *Guidance Note: Application of the Sustainable Livelihoods Framework in Development Projects*.
- Usman, F. (2018, October 5). *Pertamina Banjir Penghargaan dalam Ajang TOP CSRAWARD 2018*. Retrieved from PERTAMINA: <https://www.pertamina.com/id/news-room/energia-news/pertamina-banjir-penghargaan-dalam-ajang-top-csr-award-2018>
- Valle, S. S. (2018, March). *The concept of quality in education: its structure, dimensions and evaluation*. Mexico City: Institute National for the Evaluation of Education (Spanish). Retrieved from www.inee.edu.mx
- Waardenburg, J. (2002). *Islam: Historical, Social and Political Perspectives (Religion and Reason)*. Berlin: Walter de Gruyter.
- Wan, C. D., Sirat, M., & Abdul Razak, D. (2018). Education in Malaysia Towards a Developed Nation. *ISEAS*. Singapore.
- Williams, B., & Brown, T. (2012). Exploratory factor analysis: A five-step guide for Novices. *Australasian Journal of Paramedicine*, 8(3), 1-14.
- Woods, J. J., & Lindeman, D. (2008). Gathering and Giving Information With Families. *Infants & Young Children*, 272-284.
- Worthington, E. L., Wade, N., Hight, T., McCullough, M., Berry, J., Ripley, J., . . . Bursley, K. (2003). The Religious Commitment Inventory—10: Development, Refinement, and Validation of a Brief Scale for Research and Counseling. *Journal of Counseling Psychology*, 84-96.
- Yaacob, N. R. (2013). An Islamic Perspective on the Role of Education in Responding to Social Issues Among Students in Malaysia. *US-China Education Review*, 439-446.
- Yolanda, F. (2018, Agustus 27). *Perusahaan di Bengkulu Belum Penuhi Pengelolaan Lingkungan*. Retrieved from Republika: <https://www.republika.co.id/berita/nasional/lingkungan-hidup-dan-hutan/18/08/27/pe3ofz370-perusahaan-di-bengkulu-belum-penuhi-pengelolaan-lingkungan>
- Yonah, R. A., & Margalioth, Y. (2006). TAXATION IN DEVELOPING COUNTRIES: SOME RECENT SUPPORT AND CHALLENGES TO THE CONVENTIONAL VIEW. *1st OECDINTR Conference* (pp. 1-32). Michigan: University of Michigan Law School.
- Yulianto, A. (2017, Oktober 21). *Hasanah*. Retrieved from Republika: <https://khazanah.republika.co.id/berita/dunia-islam/khazanah/17/10/21/oy5kxx396-baitul-hikmah-mata-air-ilmu-pengetahuan>
- Yusof, Z. (1994). *Percukaaian Negara Islam: Perbandingan Percukaaian Moden dengan Islam*. Kuala Lumpur: Dewan Bahasa dan Pustaka.
- Yusyanti, D. (2016). ASPEK PERIZINAN DIBIDANG HUKUM PERTAMBANGAN MINERAL DAN BATUBARA PADA ERA OTONOMI DAERAH. *Jurnal Penelitian Hukum De Jure Volume 16*, 319.
- Zaid, M. A. (2015). *Text Book - Correlation and Regression Analysis*. Ankara Turkey: The Statistical, Economic and Social Research and Training Centre for Islamic Countries.
- Zain, N. M., Mohd Zain, N., Abdullah, N., & Ebrahimi, M. (2017). Challenges and Evolution of Higher Education in Malaysia. *International Journal of Islamic and Civilizational Studies*, 78-87.
- Zainal, H., Saad, R. A., & Abu Bakar, A. (2016). The Role of Reputation, Satisfactions of Zakat Distribution, and Service Quality in Developing Stakeholder Trust In Zakat Institutions. *International Soft Science Conference (ISSC)*.
- Zalikha, S. (2016). Pendistribusian Zakat Produktif Dalam Perspektif Islam. *Jurnal Ilmiah Islam Futura*, 304.
- Zaman, A. (2008). Islamic Economics: A Survey of the Literature. *Munich Personal RePEc Archive*, 11024.
- Zaman, N., Kamarudin, M., & Asman, N. (2017). Zakat Collection and Distribution in Malaysia. *Intercontinental Journal of Finance Research Review*, 5(2).
- Zeng, B., & Gerritsen, R. (2014). What do We Know About Social Media in Tourism? A Review. *Tourism Management Perspectives*, 10, 27-36.
- Zuhayli, W. (1999). *Fiqh dan Perundangan Islam Jilid v*. (S. A. Hussin, Trans.) Kuala Lumpur: Dewan Bahasa dan Pustaka.
- دكتوراة رسالة): الجزائر. (المسيلة جامعة حالة دراسة) المستدامة التنمية لتحقيق البشري المال رأس تنمية في الجامعة دور. (منشورة غير
ابن منظور, محمد المصري الأفريقي. (1986). لسان العرب- المجلد العاشر 2010. بيروت: دار صادر.
أبو زيد
والتوزيع للنشر العربي: القاهرة. (الأولى Vol).
إحسان الأغا، و محمود الأستاذ. (2003). مقدمة في تصميم البحث التربوي. غزة: فلسطين: الرنتيسي للطباعة والنشر.
أحمد أبو رحمة. (2017). أثر عوامل البيئة الداخلية للمنظمة على مستوى دافعية الإنجاز لدى العاملين في قطاع الخدمات بوكالة
الغوث الدولية (الأونروا). رسالة ماجستير غير منشورة - قسم إدارة الأعمال - كلية التجارة. الجامعة الإسلامية بغزة.

- أحمد الشحي. (2019). *إدارة المواد البشرية والأداء في القطاع الحكومي بين الحاضر والمستقبل*. الإمارات: دبي: JustCreative.
- أحمد حسنين. (2019). *القيادة الأخلاقية وبناء قادة الصف الثاني بالمنظمات العربية*. الأردن: عمان: دار اليازوري العلمية للنشر والتوزيع.
- أحمد غنيم. (2009). *فعاليات الإدارة بين حداثة الاتجاهات وأفضل الممارسات*. جمهورية مصر العربية: المنصورة: المكتبة العصرية.
- آدم سميت. (2016). *تروة الأمم (الجزء الأول)*. (وليد شحادة، المترجمون) دمشق: سوريا: دار فرقد للطباعة والنشر والتوزيع.
- إيوارد ج. موراي. (2017). *الدافعية والإنفعال*. (أحمد عبدالعزيز سلامة، المترجمون) دولة الكويت: مكتبة الفلاح للنشر والتوزيع.
- Retrieved 06 13, 2020, from <https://www.fahr.gov.ae>
- أشرف أحمد أبو حليم. (2018). *دافعية الإنجاز*. عمان-الأردن: دار الموهبة للنشر والتوزيع.
- الإلهام؟ ماهو Retrieved 07 05, 2019, from <https://www.makinatalafkar.com/2019/04/WhatIsInspiration.html>
- Retrieved from <https://www.fahr.gov.ae>. (2020). Retrieved from <https://www.fahr.gov.ae>. Retrieved from <https://www.fahr.gov.ae>.
- التنفيذي المجلس.
- الدليل التعريفي بجائزة محمد بن راشد للأداء الحكومي المتميز. (2018). تاريخ الاسترداد 10 01, 2019
- الرضى الفراج. (2016). قياس أثر معايير التميز على نتائج الأداء في هيئة الطيران المدني السوداني. *أطروحة مقدمة لنيل درجة دكتوراه الفلسفة في إدارة الجودة والامتياز*. السودان: جامعة السودان للعلوم والتكنولوجيا- كلية الدراسات العليا. اليمنية الجمهورية في التعليمي النظام أداء وتحسين الشاملة الجودة ثقافة بين الفجوة. (2017). ا. ع. الشريف
- Retrieved 02 16, 2020, from <https://tec.gov.ae/ar/media-centre/press-releases/2018/dgep-2018/>
- العمل سوق متطلبات يواكب لا والمهني الفني التعليم. (18 يناير، 2014). ا. ع. المشرعي
- كوم. إدارة Retrieved 02 02, 2020, from <https://edara.com/Article/details/5235>
- عن Retrieved 05 06, 2019, from <https://www.fahr.gov.ae/Portal/ar/about-fahr/about-fahr.aspx>
- الهيئة الاتحادية للموارد البشرية الحكومية. (17 10, 2019). تاريخ الاسترداد 02 02, 2020، من عن الهيئة: <https://www.fahr.gov.ae/Portal/ar/about-fahr/about-fahr.aspx>
- و العلوم والثقافة للتربية المتحدة الأمم منظمة: عمان. (2018). اليونسكو
- أمال كركود. (2016). الدوافع وأثرها على أداء العاملين في المكتبات الجامعية. *مجلة العلوم الإنسانية والاجتماعية بتبسة: الجزائر*.
- إيهاب عيسى المصري، و طارق عبدالرؤوف عامر. (2014). *السلوك التنظيمي وسلوك المنظمة*. القاهرة: المؤسسة العربية للعلوم والثقافة.
- بحر، يوسف عبدعطية. (2010). علاقة القيادة التحولية بالإبداع الإداري لدى رؤساء الأقسام الأكاديميين. *رسالة ماجستير - كلية إدارة الأعمال - إدارة الموارد البشرية*. فلسطين: الجامعة الإسلامية بغزة.
- Retrieved 02 14, 2020, from <https://www.egsep.ae>
- التميز منظومة Retrieved 10 01, 2019, from <https://www.skgep.gov.ae/>
- الحكومي
- Retrieved 02 20, 2020, from <https://www.uaeglp.gov.ae/ar/areas-of-focus>
- بسام سمير الرميدي. (2019). أثر تطبيق نمطي القيادة الموزعة والقيادة الملهمة على التهمك التنظيمي: دراسة تطبيقية على شركات السياحة المصرية. *بوابة الباحث- مجلة اقتصاد المال والأعمال المجلد (03) العدد (01) مارس 2019*، 340-354.
- بلال خلف السكارنه. (2019). *القيادة الإدارية الفعالة*. عمان: الأردن: المسيرة للنشر والتوزيع والطباعة.
- بيتر ف. دراكر. (2011). *أساسيات بيتر دراكر*. بيروت: مكتبة لبنان ناشرون.
- الربع الجليل منظومة تطبيق يبدأ المتميز الحكومي للأداء دبي برنامج Retrieved 02 16, 2020, from <https://www.elwatannews.com/news/details/1137224>
- ج. أ. كول. (2014). *الإدارة في النظرية والتطبيق*. سوريا: دار الفرقد للطباعة والنشر والتوزيع.
- Retrieved 02 14, 2020, from <https://mgov-award.ae>
- Retrieved 02 02, 2020, from <https://sharjahaward.shj.ae>

المجلد السابع- العدد الثالث عشر.

- سلى تباىى. (2019). القىاءة الإءارىة وءلاقتها بالأءاء الوظىفى لءى عمال مءىرىة الشغال العمومىة بالمسىلة. رسالة ماجسئرىر ىبر منشورة- كلىة العلوم الانسانىة والاءماعىة - آآصص الموارء البشرىة. ءامعة محمد بوضىاف بالمسىلة.
- سلىمان الءروبى. (2005). الآآفىز عن طرىق إءراك الءاء. الأراءن: عمان: ءار عالم الآآفاة.
- سلىمان عبءالله سرهان. (2018). القىاءة الملهمة والأزماء. الأراءن: ءار وائل للنشر والآوزىع.
- سمر أكمآ، و عاطف بوسف. (2014). ءرءة ممارسة مءىرى المءارس الآانوىة الآاصة للقىاءة الآابولىة وءلاقتها بءافعىة المعلمىن آنو عملهم. ءراساء، العلوم الآربوىة، المءلء (41)، ملآق (1) لسنة 2014.
- سمىر كامل محمود اللوح. (2017). ءور القىاءة الملهمة فى آعزىز الاءزام الآنظىمى بوزارة الأشغال العامة والاسكان- فلسطىن. رسالة لنبل ءرءة الماجسئرىر فى القىاءة والإءارة - ىبر منشورة . ءامعة الأقصى.
- سبء الهوارى. (1980). الآنظىم الهىاكل والسوكىاء والنظم. القاهرة: مكآبة عىن شمس .
- سبء الهوارى. (1982). الإءارة الأصور والأسس العلمىة. القاهرة: مكآبة عىن شمس.
- سبء الهوارى. (2014). القاءة الآابولىة وآعىبر المسآبل. السعوبىة: الرىاض: ءار قرطبة للنشر والآوزىع.
- سىمون سىنك. (2016). القاءة بؤآرون فىآرون (القىاءة فى الآآىر فى الآآرىن). الإماراء: ءبى: ءار قنءبل للآباعة والنشر والآوزىع.
- شائال بىرنز. (2018). الآآفىز الفورى- الآقىة المءهشة وراء ماىآفز الأداء الأفضل. مكآبة ءرىر.
- شءى عطاء. (2017). أآر القىاءة الإسآراآبىة والمعرفة فى آآقىق آمىز الأداء بشركاء الاءآلال السوءانىة. رسالة ءآوراة ىبر منشورة- مقءمة للآصول على ءرءة ءآوراة الفلسفة فى إءارة الأعمال. ءامعة السوءان للعلوم والآآنولوجىا .
- . (2018). البشرى العنصر على المعرفة إءارة آآر. (09 العءب بونىو، 2018). أ. شطىبى (2013). إ. أ. شوقار. (2013). بءارفور والاءآصاءىة الاءماعىة الآنمىة على وآآره النزاع. إ. أ. شوقار. العلىا ءراساء كلىة: الآرطوم.
- https://www.albayan.ae/across-the-uae/government-summit/2017-02-28-1.2872353 الإمارات عبر 02 02, 2020, Retrieved 02 02, 2020.
- https://www.albayan.ae/across-the-uae/news-and-reports/2019-01-13-1.3458954 الإمارات عبر 11 1, 2019, Retrieved 11 1, 2019, (2019, 01 13).
- صىاحى الأخضر. (2018). ءور القىاءة الآابولىة فى آآقىق الآمىز الآنظىمى بالمؤسسة الاءآصاءىة. أطروآة ءآوراة فى علوم الآسىبىر. ءزائر: ءامعة محمد بوضىاف بالمسىلة.
- عبء السآار إبراہىم، و رضوى إبراہىم. (2003). علم النفس أسسه ومعالم ءراسائه. السعوبىة: مطابع الءار الهندسىة.
- عبء المعطى البآىصى. (2014). ءور آمكن العاملىن فى آآقىق الآمىز المؤسسى. ءرسة مباءنىة على الكمىاء الآآنىة فى مآفاظاء قآاع عرءة -رسالة ماجسئرىر فى إءارة الأعمال. فلسطىن: ءامعة الأزهر.
- عبءالحمىء الآلىل. (2018). إءارة الموارء البشرىة. منشوراء ءامعة الاءآراضىة السوربىة.
- عبءالغفار آنفى. (2010). السلوك الآنظىمى وإءارة الموارء البشرىة. مصر: الإسكندرىة: الءار الآامعىة.
- عبءالغنى أبوالعزم. (2013). معجم الغنى الزاهر. القاهرة: ءار الغنى للنشر والآوزىع.
- عبءالكرىم بكار. (1431). اآآشاف الءاء ءلبىل الآمىز الشآصسى. الرىاض: المملكة العربىة السعوبىة: ءار وءوه للنشر والآوزىع.
- عبءاللطفى محمد آلىفة. (2000). الءافعىة للأنءاز. القاهرة: ءار ءرىب للنشر والآوزىع.
- عبءالله بنسلطان. (2014). آوكمة الآمىز- ءانزرة وزىر الءاخلىة للآمىز أنموءآاً. مءلة الفكر الشرطى- مركز بآوآ الشرطة فى القابءة العامة لشرطة الشارفة - المءلء (23) - العءب (88).
- عبءالله سلىمان. (2013). آآر ءوانز الءولة للآمىز فى آآوبىر المنظمه - ءرسة آالة شركة آاكسى ءبى. رسالة ءآوراة ىبر منشورة. السوءان: ءامعة أم ءرمان الاسلامىة.
- عبءالمءبء النشوانى. (1993). علم النفس الآربوبى (الإصاءر 6). ءار الفرقان- ءامعة الىرموك: ءامعة الىرموك- الأراءن.
- . الىمن على وآآره الإىرانى- السعوبى الصراع. (الآانى العءب مارس، 2017). أ. عرءوم . pp. 270-285.
- على الرشىبى. (2018). القىاءة الآابولىة وءلاقتها بالإبءاع الآنظىمى لءى عمءاء ورؤساء الأقسام بالآامعات الآكومىة والأهلىة بمءىنة الرىاض. المءلة العربىة للءراساء الأمنىة المءلء (33) العءب (71) الرىاض 2018. السعوبىة.
- على السلمى. (2001). إءارة الموارء البشرىة. القاهرة: ءار ءرىب للآباعة والنشر والآوزىع.
- عماء طوال. (2017). القاءة الملهم. آارىآ الاسآرءاء 26 12, 2019، من زىناء- العالم من روما: https://ar.zenit.org/articles
- فاصل، على رمضان. (2013). ءامهوربىة أفلاطون. القاهرة: ءار طبىبة - ءبىزة.
- فواز مالآ العنزى. (2015). القىاءة الملهمة كمدآل لآآوبىر الأداء وآآقىق الآمىز المءرسى. Bloomsbury Qatar Foundation. قطر: مؤآمر الآعلىم 2015 «شركاء الآمىز».
- فىصل آربشى. (2019). فعالىة الأداء الوظىفى لإءارة الموارء البشرىة وءوره فى آآقىق الأداء المآمىز للآفراء فى المؤسسة الرىاضىة. رسالة ماجسئرىر ىبر منشورة. ءزائر: ءامعة محمد بوضىاف بالمسىلة.
- قابن آسىن. (2017). النمط القبائى للمءراء وءلاقتة بءافعىة الأنءاز لءى الطاقم الإءارى فى المركباء الرىاضىة - بولابء ءبىل. ءامعة آمء بوضىاف بالمسىلة. رسالة ماجسئرىر ىبر منشورة - ءامعة آمء بوضىاف بالمسىلة.

- قاسم علوان. (2005). *إدارة الجودة الشاملة*. بيروت: دار الثقافة للنشر والتوزيع.
- □□□□□□□□. (2019). Retrieved 5 5, 2019, from تعريف : <https://www.almaany.com/ar/dict/ar-ar/%D8%A7%D9%84%D8%A5%D8%AF%D8%A7%D8%B1%D8%A9/>
- □□□□□□□□□□. (2010, 11 3). Retrieved 8 30, 2019, from إلهام: <https://www.almaany.com/ar/dict/ar-ar>
- □□□□□□□□□□. (2010). Retrieved 12 26, 2019, from الدافعية: <https://www.almaany.com/ar/dict/ar-ar/%D8%A7%D9%84%D8%AF%D8%A7%D9%81%D8%B9%D9%8A%D8%A9/>
- قانون الموارد البشرية في الحكومة الاتحادية. (أكتوبر، 2016). *الهيئة الاتحادية للموارد البشرية*.
- قيس محمد علي وليد سالم حموك. (2014). *الدافعية العقلية رؤية جديدة*. عمان الأردن: مركز دبيونو لتعليم التفكير.
- كلوس شواب. (2016). *الثورة الصناعية الرابعة*. جنيف: سويسرا: المنتدى الاقتصادي العالمي.
- لورانس أ. برافين. (2010). *عالم الشخصية، الجزء الأول*. (عبدالحليم محود السيد، أيمن محمد عامر، ويحي محمد الرخوي، المترجمون) القاهرة: المركز القومي للترجمة.
- ماجد الخياط. (2017). *العلاقة بين الإثراء الوظيفي والدافعية للعمل لدى العاملين في جامعة البلقاء التطبيقية: دراسة تطبيقية مسحية لموظفي مركز الجامعة*. مجلة جامعة النجاح للإبحاث للعلوم الإنسانية: الأردن - المجلد (31) العدد (08) 2017.
- ماريا محمد، الشريف أسعد، و إدريس ناصر. (2017). دور الرضا الوظيفي في تحقيق دافعية الإنجاز لدى العاملين في وزارة المالية بولاية البحر الأحمر. مجلة جامعة البحر الأحمر للعلوم الإنسانية - العدد (4) ديسمبر 2017.
- ماهر محمد صالح حسن. (2004). *القيادة أساسيات ونظريات ومفاهيم*. الأردن: دار الكندي للطباعة والنشر.
- مجاهد رشيد. (2016). أثر دوافع العمل والتحفيز كوسيلة لتحقيق الرضا الوظيفي والأداء في المنظمة. مجلة الاقتصاد التطبيقي والإحصاء المجلد (11) ، العدد (2)، 114-99.
- مجلة صدى الموارد البشرية. (01 11, 2017). تاريخ الاسترداد 06 13 2020، من الهيئة الاتحادية للموارد البشرية الحكومية- مجلة شهرية العدد (7): www.fahr.gov.ae
- مجلة صدى الموارد البشرية. (2018). تاريخ الاسترداد 03 08 2020، من الهيئة الاتحادية للموارد البشرية الحكومية - مجلة شهرية العدد (91): www.fahr.gov.ae
- محمد التويجري، و محمد البرعي. (1993). *معجم المصطلحات الإدارية*. الرياض: المملكة العربية السعودية: مكتبة العبيكان.
- محمد الصيرفي. (2006). *القيادة الإدارية والإبداعية*. مصر- الإسكندرية: دار الفكر الجامعي.
- محمد بن راشد آل مكتوم. (2018). *قصتي*. الإمارات العربية المتحدة- دبي: إكسبلور للنشر والتوزيع.
- محمد زائيري. (2007). *التميز في الأداء- دليل عملي*. (هانني وليم، المترجمون) الإمارات: دبي: مركز التعريب والنشر: الكلية الإلكترونية للجودة الشاملة.
- محمد قاسم القريوتي. (2013). *مقدمة في الإدارة العامة*. الكويت: مكتبة الفلاح للنشر والتوزيع.
- محمد قاسم عبدالله. (2000). *الشخصية والعلاج النفسي*. سوريا- دمشق: دار المكتبي للطباعة والنشر والتوزيع.
- محمود الشنطي. (2016). أثر ممارسة أساليب القيادة التحويلية في جودة الحياة الوظيفية- دراسة تطبيقية على وزارة الصحة الفلسطينية. *المجلة الأردنية في إدارة الأعمال*. المجلد 12 العدد 1 2016. جامعة القدس المفتوحة.
- محمود العميان. (2018). *السلوك التنظيمي في منظمات الأعمال*. الأردن: دار وائل للنشر والتوزيع.
- محمود المساد. (2003). *الإدارة الفعالة*. بيروت- لبنان: مكتبة لبنان ناشرون.
- محمود سمير محمد الحلبي. (2017). دور القيادة الملهمة في توظيف مخرجات البحث العلمي في وزارة الداخلية والأمن الوطني الفلسطيني. *أطروحة للحصول على درجة الماجستير في القيادة والإدارة*. أكاديمية الإدارة والسياسة للدراسات العليا- مسار النخبة.
- مختار نور الدين عثمان. (2014). *الإدارة والقيادة التربوية*. الكويت: دار حنين للنشر والتوزيع.
- مدحت أبو النصر. (2015). *قادة المستقبل: القيادة المتميزة الجديدة*. مدينة نصر: القاهرة: المجموعة العربية للتدريب والنشر.
- مسكين عبدالله. (2015). السلوك القيادي لدى المشرفين التربويين في التعامل مع المعلمين- دراسة استطلاعية للمشرفين في التربية والتعليم بمديرية التربية لولاية مستغانم. *مخبر تطوير الممارسات النفسية والتربوية العدد (15)*. جامعة وهران: الجزائر.
- مصطفى يوسف كافي. (2018). *إدارة المواهب البشرية في المنظمات*. الجزائر: ألفا للوثائق نشر واستيراد وتوزيع الكتب.
- معجم لسان العرب لابن منظور. (بلا تاريخ). تاريخ الاسترداد 1 6 2020، من دفع: <http://wiki.dorar-aliraq.net/lisan-alarab/%d8%af%d9%81%d8%b9>
- منال البارودي. (2016). *القائد المتميز وأسرار الإبداع القيادي*. القاهرة: المجموعة العربية للتدريب والنشر.
- منصور بن زاهي. (2007). الشعور بالاغتراب الوظيفي وعلاقته بدافعية الإنجاز لدى الإطارات الوسطى لقطاع المحروقات. جامعة منتوري- قسنطينة - علم النفس وتسيير الموارد البشرية. الجزائر.
- منصور بن زاهي. (2007). الشعور بالاغتراب الوظيفي وعلاقته بدافعية الإنجاز لدى الإطارات الوسطى لقطاع المحروقات. جامعة منتوري- قسنطينة - علم النفس وتسيير الموارد البشرية. الجزائر.

- منصور بن زاهي. (2007). الشعور بالاغتراب الوظيفي وعلاقته بدافعية الإنجاز لدى الإطارات لقطاع المحروقات. جامعة منتوري الفلاسطينية. كلية العلوم الإنسانية والاجتماعية.
- الحكومي للتميز خليفة الشيخ برنامج (2019). Retrieved 10 01, 2019, from <https://www.skgep.gov.ae/>
- منى جواد سلمان. (2018). الحوكمة في ضوء نماذج التميز المؤسسي. الشارقة: مكتبة الجامعة.
- منى سلمان. (2006). فنون التوثيق ومهاراته- دليل المتميزين في توثيق الأداء المهني المقدم للجوائز التربوية. الإمارات: مكتبة دبي للتوزيع.
- ناجي الشريف. (2017). الأداء الوظيفي لدى الموظفين الإداريين في جامعة نجران. المجلة الدولية التربوية المتخصصة- المجلد (6). العدد (8). العراق.
- نظام منح المكافآت والحوافز. (2015). تاريخ الاسترداد 03 08, 2020، من الهيئة الاتحادية للموارد البشرية الحكومية: www.fahr.gov.ae
- نواف كنعان. (1995). القيادة الإدارية. عمان- الأردن: دار الثقافة للنشر والتوزيع.
- هانم العيسوي. (2019). الإدارة التشاركية إدارة جيل الألفية. جمهورية مصر العربية: الاسكندرية: مركز ليفانت للدراسات الثقافية والنشر.
- هشام بوكفوس. (2006). أساليب تنمية الموارد البشرية في المؤسسة الاقتصادية العمومية الجزائرية. جامعة الإخوة منتوري. كلية العلوم الإنسانية والاجتماعية.
- حكومة قيادات برنامج (2019). Retrieved 01 13, 2019, from <https://www.mocaf.gov.ae/%D8%A7%D9%84%D8%A3%D9%86%D8%B4%D8%B7%D8%A9-%D8%A7%D9%84%D8%B1%D8%A6%D9%8A%D8%B3%D9%8A%D8%A9/%D9%82%D9%8A%D8%A7%D8%AF%D8%A7%D8%AA-%D8%AD%D9%83%D9%88%D9%85%D8%A9-%D8%A7%D9%84%D8%A5%D9%85%D8%A7%D8%B1%D8%A7%D8%AA>
- ويليام أرودا، و كرسنتين ديكسون. (2018). استراتيجيات صناعة التميز الشخصي والمؤسسي. (زكي القاضي، و محمد ابوضيف، المترجمون) جمهورية مصر العربية: مدينة نصر : المجموعة العربية للنشر والتوزيع.
- ياسر كداو. (2016). إدارة الموارد البشرية بين النظرية والتطبيق. دبي: دار الكتب.
- ياسين المحارمة. (2017). مدى معرفة معلمي التربية الرياضية المشاركين بجائزة الملك عبد الله الثاني للياقة البدنية بمتطلبات الجودة الشاملة من وجهة نظر مديريهم. مجلة المنارة للبحوث والدراسات المجلد (23)، العدد (3). الأردن.
- يحي جاسر أبو جودة. (2019). النزاهة الاجتماعي ودافعية الإنجاز. (عمان- الجامعة الأردنية، المحرر) المملكة الأردنية الهاشمية: دار زهدي للنشر والتوزيع.
- يوشيو كونو. (2005). التحفيز الإنساني عامل أساسي في الإدارة. الإمارات: دبي: مركز التعريب والنشر بالكلية الإلكترونية للجودة الشاملة.

JUDGES AUTHORITY IN BANKING DISPUTES IN ISLAMIC BANKS IN THE UNITED ARAB EMIRATES

Sharifa Rashed Al Suwaidi

سلطة القاضي في المنازعات المصرفية في البنوك الإسلامية في دولة الإمارات العربية المتحدة
المحور : لجنة التحكيم
إعداد الدكتور ه : شريفة راشد السويدي
2020م

ماهية المنازعات المصرفية وسلطة القاضي فيهما من خلال لجنة التحكيم

المعاملات المصرفية مفاعلة من جانبين، المصرف من جانب والعمل من جانب آخر أو بين مصرف ومصرف آخر؛ لذا فإن المعاملة المصرفية لا تخلو من نزاع سواء أكان هذا النزاع منشؤه طبيعة المعاملة وما يعتريها من إشكاليات، أو ما يطرأ على العقد من تغيرات أو غير ذلك من الأسباب، فكان من الواجب حلها وفق ما تقضي به النظم والقوانين لاستقرار المعاملات، والمحافظة على الحقوق المترتبة على هذه المعاملات. ومن الثابت أن النزاع في الشريعة الإسلامية ينتهي بالصلح والتحكيم والقضاء .
يقصد بالمنازعات المصرفية " الخلاف الذي يقع بين طرفين أحدهما بنك و عميله، أو بنك وآخر، نتيجة ممارسة البنك عملاً مصرفياً " . (جنوبي 2016م) .

أما الخصومة فتعرف على أنها : " مجموعة الإجراءات القضائية التي يقوم ببعضها الخصوم، وبعضها الآخر القاضي وأعوانه وتبدأ بالمطالبة وتنتهي بالحكم الصادر في موضوعها " . (الصويلح 2010م)

ويتفرع عن هذا التعريف مصطلح فض المنازعات . وهو مصطلح للتعبير عن مجموعة من الأفكار والطرق المستخدمة للحد من النزاع . تتضمن عملية فض النزاعات بشكل عام التفاوض والوساطة والدبلوماسية . وتوصف عملية التحكيم والدعاوى القضائية والشكوى الرسمية بـ " فض الخلافات " وأحياناً " فض النزاعات " (جنوبي 2016) فقد يتفق أطراف النزاع على حله عن طريق طرف ثالث مع إعطائه سلطة حسم النزاع أي أن ما يحكم به يعد ملزماً لهم دون حاجة إلى موافقة لاحقة من جانبهم من خلال القضاء أو التحكيم أو اللجان المختصة كلجنة التوفيق والمصالحة . وأعرف سلطة القاضي بأنها : قدرة القاضي على الفصل بين الخصومات والمنازعات .

تتعدد وسائل فض المنازعات المصرفية في دولة الإمارات العربية المتحدة بدءاً من خارج المحاكم - وهي على سبيل المثال لا الحصر - مركز أبوظبي للتوفيق والتحكيم التجاري - مركز دبي للتحكيم الدولي - مركز دبي المالي العالمي - المركز الإسلامي الدولي للمصالحة والتحكيم بدبي - الشركات الخاصة ودور هافي فض المنازعات المصرفية إلى وسائلها داخل المحاكم كلجان التوفيق والمصالحة والتحكيم والصلح ثم يأتي دور القضاء للفصل بين المتخاصمين إذا تعذرت كل الوسائل السابقة في التوصل إلى الإصلاح وإيجاد الحلول المناسبة . وما سأتعرض له هو سلطة القاضي في المنازعات المصرفية في البنوك الإسلامية في دولة الإمارات العربية المتحدة من خلال لجنة التحكيم وهي عنوان الورقة .

النتائج:

1. من الثابت أن النزاع في الشريعة الإسلامية ينتهي بالصلح والتحكيم والقضاء ، أما مصادر الحكم القضائي في الشريعة هي القرآن والسنة والاجماع والاجتهاد والمصالح المرسله وسد النرائع ومقاصد الشريعة والسوابق القضائية ، أما مصادره في القانون فهي العقد الموقع بين الاطراف والقوانين المدنية والأعراف التجارية والتشريع .. الخ .
2. تتعدد وسائل فض المنازعات بدءاً من خارج المحاكم - وهي على سبيل المثال لا الحصر - مركز أبوظبي للتوفيق والتحكيم التجاري - مركز دبي للتحكيم الدولي - مركز دبي المالي العالمي - المركز الإسلامي الدولي للمصالحة والتحكيم بدبي - الشركات الخاصة ودور هافي فض المنازعات المصرفية إلى وسائلها داخل المحاكم كلجان التوفيق والمصالحة والتحكيم والصلح .
3. تتكامل سلطة القاضي مع لجنة التحكيم في فض العديد من نزاعات المصارف الإسلامية المتنازعة .

سأتناول في هذه الورقة محورين :

- المحور الأول : صور المنازعات المصرفية في البنوك الإسلامية في دولة الإمارات العربية المتحدة .
- المحور الثاني : سلطة القاضي في المنازعات المصرفية في البنوك الإسلامية في دولة الإمارات العربية المتحدة من خلال لجنة التحكيم .
- المحور الأول : صور المنازعات المصرفية في البنوك الإسلامية في دولة الإمارات العربية المتحدة :
سأستعرض صوراً للمنازعات المصرفية استخلصتها من القضايا الواقعة في أروقة المحاكم بدولة الإمارات العربية المتحدة ومنها :
 1. امتناع المصرف عن تنفيذ أمر عميله بغير مبرر بنقل مبلغ من حسابه إلى حساب آخر (هو المستفيد) مما سبب ضرراً للعميل . (عبدالله حسن 2001م)
 2. إهمال البنك في متابعة أمر الشيكات الضامنة لسداد المديونيات، وعدم اتخاذها إجراء قانونياً ضد الساحب عند رجوع الشيكات، وقبل مغادرة الساحب الدولة . (دائرة القضاء من 2008-2010م) .
 3. عدم تحقق البنك من شخصية العميل أدى إلى الوقوع في عمليات النصب والاحتيال والتزوير . (هاني اسماعيل 1988-1999م)
 4. عدم فحص البنك الوثائق الخاصة بالاعتمادات المستندية والتأكد من مطابقتها لشروط وتفاصيل الاعتماد أدى إلى حدوث المنازعات . (د. عوض الحسن النور، 2006م) .
 5. تضرر العميل بسبب خطأ من البنك من جراء التحويل المصرفي (عبدالله حسن ، 2001م)
 6. وقوع أخطاء في كشوفات الحساب التي جرى العرف المصرفي اعدادها وارسالها للعملاء . (دائرة القضاء 2008-2010م)
 7. إيداع مبلغ بطريق الخطأ ، وإعادة المبلغ إلى حساب المدعي دون أن يعيد المدعي عليه الفوائد التأخيرية . (فتيحة محمود قره ، 2012 م) .
 8. حرمان البنك من تصرف العميل بتجميد أمواله بغير إذن من القضاء . (فتيحة محمود قره ، 2012 م)
 - 9- عدم التمييز بين الاعتمادات المستندية والمرابحة في بعض البنوك . (المكتبة القانونية ، 2015م)
 - 10 أخطاء يقع فيها الخبير (كعدم تحديد أصل مبلغ المديونية، أو كيفية احتساب الفوائد عليه ، لم يحدد السعر السائد لها بالسوق في حالة عدم الاتفاق عليها .) (المكتبة القانونية ، 2015م) .

11. الفائدة الربوية والاختلاف في تقدير سعر الفائدة بين المتنازعين. (الطعن رقم 103 لسنة 14 ق جلسة 27-2-1993 و الطعن رقم 58 لسنة 22 المحكمة الاتحادية العليا). علماً أن القانون الإماراتي جرم الربا وتوعد المتعاملين به بالعقوبة كما قالت المادة 409 من قانون العقوبات الاتحادي لعام 2016. (المرزوقي، 2018م)

12. رفض قبول المستندات لكونها محررة بلغة أجنبية. (مكتب محاماة حكم قطعي - تجاري جزئي - 2012م).

13. القرض والسحب على المكشوف وإصدار الكفالات المصرفية أحد أسباب التنازع. (حكم قطعي تاريخه 2010 مكتب محاماة بدي).

14. قلة الوعي والعلم بالشروط والأحكام التي تصدر من البنوك، والمخاطر التي يمكن أن تكتنف العقود مما يكون سبباً لحدوث التنازع.

15. رفض البنك صرف شيك للعميل رغم أن نصوص العقد يخول له الحق في سحب الشيكات (د. عوض الحسن النور، 2006).

المحور الثاني: سلطة القاضي في المنازعات المصرفية في البنوك الإسلامية في دولة الإمارات العربية المتحدة

مع ازدياد الاهتمام بالتحكيم واتساع نطاقه لم تعد النصوص تكفي بل أصبحت الحاجة ملحة لإصدار تشريع خاص ينظم جميع الأمور المتعلقة بالتحكيم وهو ما تسعى إليه الجهات المختصة.

والحديث في هذا الفصل من منظور قانوني يدور حول تعريف التحكيم وأنواعه، وشروط صحة الاتفاق على التحكيم في الفقه والقانون، ومن منظور إسلامي فإن المنازعات المصرفية من خلال التحكيم تحكمها الكثير من الضوابط، بما يشمل فصل القول في المنازعة، وتطبيقاتها كثيرة ومتعددة، وقد حسم الفقهاء المعاصرون الرأي فيها.

وتتمة للفائدة فقد قسمت هذا المحور إلى ستة مطالب:

المطلب الأول: تعريف التحكيم في الفقه الإسلامي والقانون الإماراتي، المطلب الثاني: أركان التحكيم في الفقه الإسلامي والقانون الإماراتي، المطلب الثالث: أنواع التحكيم في الفقه الإسلامي والقانون الإماراتي، المطلب الرابع: التكييف الفقهي لشرط التحكيم في العقود، المطلب الخامس، المطلب السادس: سلطة القاضي في التحكيم في الفقه الإسلامي والقانون: المآخذ والحلول للتحكيم في المنازعات المصرفية الإسلامية الإماراتية

المطلب الأول: تعريف التحكيم في الفقه الإسلامي والقانون الإماراتي

أولاً: التحكيم في الاصطلاح الفقهي

التحكيم مشتق من الحكم، والعرب يقول: حَكَمْتُ بِمَعْنَى مَنَعْتُ ومن هذا قيل للحاكم بين الناس حاكم؛ لأنه يمنع الظالم من الظلم. (الهرودي (ت: 370هـ) تحقق: محمد عوض مرعب 2001م) وهيئة التحكيم: هيئة أو لجنة تقوم بالحكم في القضاء، وبين الأطراف المتنازعة، وفي المباريات الرياضية ونحوها. (معجم اللغة العربية المعاصرة، د. أحمد مختار (ت: 1424هـ) عالم الكتب 2008 م).

جاء في تعريف التحكيم عند الفقهاء: تحكيم رجل عدل غير خصم فإن وقع مضي وإلا لم يصح ولم ينفذ في مال غير متعلق بغائب. (الصاوي المالكي (ت: 1241هـ)).

وقد عرّف مجمع الفقه الإسلامي الدولي التحكيم بأنه: اتفاق أطراف الخصومة على تولية من يفصل في منازعة بينهما، بحكم ملزم، يطبق فيه شرع الله. (مجلة مجمع الفقه الإسلامي، 1995م).

ثانياً: التحكيم في القانون الإماراتي:

جاء في معنى التحكيم في المادة الأولى من القانون الاتحادي رقم (6) لسنة 2018م أنه " وسيلة ينظمها القانون يتم من خلالها الفصل بحكم ملزم في نزاع بين طرفين أو أكثر بواسطة هيئة التحكيم بناء على اتفاق الأطراف ". أما التحكيم الإلكتروني فيرجع لاستخدام الأطراف لوسائل إلكترونية سواء عند إبرام التحكيم أو أثناء سريان خصومة التحكيم. (الشهابي 2013) يفهم مما سبق أن التحكيم يقوم على أساسين مهمين هما: اتفاق الخصوم على اللجوء للتحكيم وعدم اختصاص القضاء وحده في حل النزاعات القائمة بين الأفراد.

وتطبيقاً لذلك نصّ في المادة (5) لسنة 2018م على أنه:

" يجوز الاتفاق على التحكيم من خلال الإحالة التي ترد في أي عقد أو أي وثيقة أخرى تتضمن شرط التحكيم إذا كانت هذه الإحالة واضحة في اعتبار هذا الشرط جزءاً من العقد "

المطلب الثاني: أركان التحكيم في الفقه الإسلامي والقانون الإماراتي

أولاً: أركان التحكيم في الفقه الإسلامي:

أركان التحكيم في الفقه الإسلامي هي: أطراف التحكيم والمحكم وصيغة التحكيم ومحل التحكيم، وهي شروط أي عقد. (الكاساني (ت: 587هـ)، دار الكتب العلمية، 1986م، القرافي (ت 684هـ) دار الغرب الإسلامي، 1994م، النووي (ت: 676هـ) المكتب الإسلامي، 1992م، بن مفلح المقدسي (ت: 884هـ) المكتب الإسلامي، 1974م).

وسأتناول في هذا الجزء بعض الآداب في استماع الدعوى والشهادة، وأنب التعليل؛ من خلال ما أورده الإمام السعدي -رحمه الله- حيث استخلصت منها بعض شروط التحكيم ومنها: (السعدي، (ت: 461هـ) تحقق: صلاح الدين الناهي 1984م)

● إذا لم يفهم كلام الخصم يترجم فيما بينهما رجلان في قول محمد، ويجوز ترجمة رجل واحد في قول أبي حنيفة وأبي يوسف. (النفري، القيرواني، المالكي (المتوفى: 386هـ) تحقق: د. الفتح محمد الحلو، وآخرون 1999)

● أن يعرف المدعي من المدعى عليه حتى يكلف المدعي البينة ويستحلف المدعى عليه. وفيه استدلال على تحديد موضوع النزاع.

● أن يكتب شهادة الشهود في صحيفة ثم يطوبها ويختتمها ويكتب عليها هذه خصومة فلان بن فلان. وهذا يدل على أهمية الكتابة وتوثيقها.

● أن يكون كاتبه مسلماً من أهل العفاف والأمانة. وهذا يدل على شروط وكمال الأهلية.

● أن يتعرف ما كتب من الخصومة والشهادة. وفيها أيضاً (تحديد موضوع النزاع).

ثانياً: أركان التحكيم في القانون الإماراتي:

الرضا: وهو وسيلة لحل المنازعات التي سوف تنشأ أو نشأت بينهما، وأن تكون إرادة الطرفين خالية من عيوب الرضا المنصوص عليها في قانون المعاملات المدنية. (جاويد، 2014م)

2- الأهلية: جاء في المادة (4) " ..لا ينعقد الاتفاق على التحكيم إلا من الشخص الطبيعي الذي يتمتع بأهلية التصرف في الحقوق أو من ممثل الشخص الاعتباري المفوض في إبرام الاتفاق على التحكيم وإلا كان الاتفاق باطلاً". (القانون الاتحادي بشأن التحكيم 2018م)

لا يكون التحكيم في المسائل التي لا يجوز فيها الصلح وهي المسائل التي تتعلق بالنظام العام. ولا يجوز في التحكيم الإسلامي تحكيم عقود تخالف أحكام الشريعة الإسلامية. (الشهابي 2013م)، (قانون اتحادي 2018م مادة 11).

ويشترط لصحة التحكيم ما يأتي: (الشهابي 2013)
 أ. قيام نزاع بين طرفين أو أكثر حول حق مشروع، وأن يكون السبب الذي دفع الطرفين لاختيار التحكيم مشروعاً وعاكساً لقصد من الاتفاق على التحكيم التهرب من أحكام القانون الذي كان سيتعين تطبيقه لو طرح النزاع على القضاء أيضاً كحالات الغش، فلا يكون سبباً وهمياً.
 ب. اتفاق طرفي النزاع على التحكيم وتراضيهم على قبول حكم المحكم. (المادة 7 قانون اتحادي 2018م).
 ج. قبول المحكم لمهمة التحكيم.
 د. الكتابة: حيث لا يثبت الاتفاق على التحكيم إلا بالكتابة، وإلا فلا يقبل القول بوجود شرط تحكيم أو اتفاق عليه دون كتابة. مادة 7 قانون اتحادي بشأن التحكيم 2018م)

هـ. يجب على المحكمة التي يرفع إليها نزاع يوجد بشأنه اتفاق التحكيم أن تحكم بعدم قبول الدعوى إذا دفع المدعى عليه بذلك قبل إبدائه أي طلب أو دفع في موضوع الدعوى وذلك ما لم يتبين للمحكمة أن الاتفاق على التحكيم باطل أو يستحيل تنفيذه. (المادة 8 قانون اتحادي بشأن التحكيم 2018م)

و. لا يجوز أن يكون المحكم قاصراً أو محجوراً عليه أو محروماً من حقوقه المدنية بسبب عقوبة أو مفلساً ما لم يرد إليه اعتباره. (مادة 10 قانون اتحادي بشأن التحكيم 2018م)

ز. إذا تعدد المحكمون لا بد أن يكون العدد وتراً. (مادة 9 قانون اتحادي بشأن التحكيم 2018م)
 المطلب الثالث: أنواع التحكيم الفقه الإسلامي والقانون الإماراتي:

أولاً: أنواع التحكيم في الفقه الإسلامي

جاء في التحكيم على سبيل المثال؛ التحكيم في القصاص والحدود؛ التحكيم في الحدود والقصاص لا يصح إذ التحكيم يكون في سائر المجتهدات؛ أي المسائل التي يسوغ فيها الاجتهاد من حقوق العباد كالطلاق والعتاق والكتابة والكفالة والشفعة والنفقة والديون والبيوع بخلاف ما خالف كتاباً أو سنة أو إجماعاً. (الكاساني، مرجع سابق، ابن عابدين (ت: 1252 هـ) دار الفكر، 1992م).

كما اتفق الفقهاء في التحكيم في الأموال بلا خلاف. (علي المرغيناني، (ت: 593 هـ) الماوردي، (ت: 450 هـ) تحق: علي محمد معوض وعادل عبد الموجود، 1999م المرادوي الحنبلي (ت: 885 هـ))

قال المالكية: "الولاية الخاصة وهي التحكيم -وفي الجواهر- جائز في الأموال، وما في معناها فلا يقيم المحكم حداً ولا يلاعن ولا يحكم في قصاص أو طلاق أو عتق أو نسب أو ولاء لقصور ولايته وضعفها". (القرافي (ت: 684 هـ) تحق: سعيد أعراب، 1994م).

ثانياً: أنواع التحكيم في القانون الإماراتي: (الشوربجي 2014م جاويد 2014م)

من أنواع التحكيم ما يأتي:

أولاً: التحكيم الحر: وهو الذي يقوم فيه أطراف النزاع أنفسهم باختيار محكميهم وقواعد التحكيم وإجراءاته، ودون الإشارة إلى مؤسسة تحكيم.

ثانياً: التحكيم المؤسسي: وهو أن يتفق الأطراف على أن يجري التحكيم بواسطة ومعرفة مركز دائم للتحكيم أو مؤسسة تحكيم دائمة.

ثالثاً: التحكيم الدولي: ويكون عندما يتفق الأطراف في نزاع ذي صفة دولية أو يتضمن عنصراً أجنبياً على حله باللجوء إلى التحكيم.

رابعاً: التحكيم الوطني: وهو ما يتم في النزاعات التي تقع داخل دولة واحدة وتخلو من علاقة أجنبية. (الشوربجي 2014م)

خامساً: التحكيم مع التفويض بالصلح: وهو أن يتفق أطراف النزاع على حله بتطبيق قواعد العدالة دون إلزام المحكم بقواعد القانون الموضوعي فيحكم المحكم لكل طرف بجزء من ادعاءاته كما هي القاعدة المعروفة في الصلح، ولا يجوز التحكيم في المسائل التي لا يجوز فيها الصلح. (الشوربجي 2014م) مادة 4 قانون اتحادي بشأن التحكيم 2018م).

المطلب الرابع: التكيف الفقهي لشرط التحكيم في العقود

انقسم الفقهاء إلى قولين: لزوم عقد التحكيم وعدم لزومه.

رأي القائلين بلزوم عقد التحكيم: ذهب أبو حنيفة ومالك وأحمد بلزوم العقد، وذهب الشافعي في أحد القولين بعدم لزومه إذا جوزنا التحكيم لم يلزمهما (أبو عبد الله المواق المالكي (ت: 897 هـ) دار الكتب العلمية، 1994م). حكمه إلا بتراضيهم. (السرخسي (ت: 483 هـ) دار المعرفة 1993م)

النووي، (ت: 676 هـ)، تحق: محمد نجيب المطيعي، بن مفلح المقدسي (ت: 884 هـ) 1974م).

واستدلوا: قوله تعالى: ﴿وَإِنْ خِفْتُمْ شِقَاقَ بَيْنِهِمَا فَابْتَغُوا حَكْمًا مِنْ أَهْلِهِ وَحَكْمًا مِنْ أَهْلِهَا إِنْ يُرِيدَا إِصْلَاحًا يُوَفِّقِ اللَّهُ بَيْنَهُمَا﴾ النساء 35/.

(العبادي الزبيدي (المتوفى: 800 هـ) المطبعة الخيرية، 1322 هـ) (الصحابة - رضي الله عنهم - كانوا مجمعين على جواز التحكيم

رأي القائلين بعدم لزوم عقد التحكيم:

عقد التحكيم المصرفي عقد رضائي يجب ألا يشوبه أي عيب من عيوب الرضا والتي تتمثل في الإكراه والغلط والغبن. (عاصم محمد 2017م).

وأن مجلس مجمع الفقه الإسلامي، قرر أن التحكيم عقد غير لازم لكل من الطرفين المحتكمين، بمعنى: أن كل واحد من المتنازعين يجوز له نقض التحكيم، وأن المتنازعين يمكنهما عزل المحتكم إليه وأن المحتكم إليه يستطيع عزل نفسه. (مجلة مجمع الفقه الإسلامي 1995م)، واستدلوا:

1- القياس على الوكالة فاعتبره من عقود التبرع حيث للموكل الحق في فسخ عقد الوكالة. (محمد الافي 1997، مجلة مجمع الفقه الإسلامي، 1995م).

2- القياس على الفتيان: فالشخص غير ملزم بأخذ الفتوى كذلك هو في التحكيم غير ملزم. (المجمع الفقهي الإسلامي، عجيل النشمي 2010م)

الراجح: لزوم عقد التحكيم: القول بعدم لزومية التحكيم يؤدي إلى خلخلة العقد وعدم الفائدة من الشرط.

المطلب الخامس: المآخذ والحلول للتحكيم في المنازعات المصرفية الإسلامية:

أولاً: المآخذ:

وجدت بعض المآخذ من المصرفيين على التحكيم، لكن حتمية التحكيم في منازعات الصيرفة الإسلامية واردة للأسباب الآتية:

1- إن طبيعة المنازعة هي التي تفرض الاستعانة بأشخاص متخصصين؛ وأثبت الواقع نجاح كثير من القضايا التحكيمية. (عز الدين أبو بكر 2010م)، فقد

ارتفع عدد قضايا التحكيم التي تعامل معها مركز دبي للتحكيم الدولي منذ إنشائه، بسبب الوعي لدى مجتمع رجال الأعمال في المنطقة بأهمية التحكيم في تسوية المنازعات، حيث سجل المركز من 2003 وحتى العام الماضي 2430 قضية/ http://www.alkhaleej.ae/economics/page.

2015

2- السرعة والمرونة: والمرونة في إجراءات التحكيم؛ بأن يكون للأطراف اختيار الإجراءات الواجبة التطبيق على التحكيم، كما للمحكمن تفسير ما يرد في حيثيات

القضية وثابت ذلك في محاضرهم. (القانون الاتحادي بشأن التحكيم، مادة 49).

هذه الميزة يراها المصرفيون على أنها سبباً باعتبار أن المرونة من وجهة نظرهم تعني عدم استقرار القواعد القانونية وبالتالي مخاطر إضافية. (خليل مري، أيب ميالة 2010م).

4- إن تكلفة التحكيم من الناحية المالية لا تقاس بالنفقات المترتبة على التأخير في تنفيذ العقود، ولا سيما إذا تعلق الأمر بالمعاملات المصرفية، إذ يُعد عنصر الزمن فيها مؤشراً هاماً في تنفيذ الصفقات التجارية، فالتأخير في تنفيذها يؤدي إلى وقوع خسائر مالية كبيرة بين الأطراف المتنازعة (القانون الاتحادي بشأن التحكيم، مادة 46). (عز الدين أبو بكر 2010م)

1- إن صعوبة نظر المنازعات المتعددة الأطراف تعتبر طبيعية، ولتفادي المشكلات الناجمة عن تعدد الأطراف يجوز تضمين العقد على إلزام جميع المدعي عليهم بالانضمام إلى شروط التحكيم الواحد. (خليل ممتري، أديب ميالة 2010م) (عز الدين أبو بكر 2010م).

ثانياً: الحلول: عوامل نجاح التحكيم المصرفي. (خليل ممتري، أديب ميالة 2010م)
من الحلول السهلة هو إيجاد قواعد تخفف من مأخذ المصرفين على التحكيم ومنها:

- إعداد شروط تحكيم متماسكة: يقترح على المصرف المركزي إيجاد آلية موحدة للمصارف أن تشمل جميع عقودها شرطاً تحكيمياً لحل أي نزاع ينشأ بين المصرف.
- النص على تطبيق الأعراف المصرفية: إن النص على تطبيق الأعراف المصرفية كقانون على المحكمين وإلزامهم بوسائل إثبات اتفاقية بين الفرقاء، وأن قرار المحكمين غير قابل للاستئناف أو الطعن لتجنب الرجوع إلى السلطة القضائية.
- اللجوء إلى تحكيم مؤسسي: يجب إخضاع المؤسسة التحكيمية للمصرف المركزي ويجب إدارتها كمؤسسة قضائية.
- تجاوز صعوبات التنفيذ: يقترح على المصرف المركزي إحداث هيئة للوساطة والتحكيم من مهامها البت في النزاعات التي تنشأ بين أطرافها؛ أي علاقة مصرفية. يكون من أهدافه حل النزاعات المصرفية
- تشكيل الهيئة: لإعطاء الصفة القانونية للهيئة التحكيمية يجمع أعضاء مجلس إدارة الهيئة بين الصفة القضائية والمصرفية وبين القطاع العام والخص على أن يرأس الهيئة قاض له خبرة في القضايا التجارية.
- تنفيذ القرارات التحكيمية الصادرة عن هيئة التحكيم التابعة للمصرف المركزي يتطلب تعاون بين المصرف المركزي والسلطة القضائية، وهذا يعني منح المحكمين (هيئة التحكيم التابعة للمصرف المركزي) صلاحية إصدار القرارات المعجلة النفاذ. (خليل ممتري، أديب ميالة 2010م)

المطلب السادس: سلطة القاضي في التحكيم في الفقه الإسلامي والقانون الإماراتي

أولاً: سلطة القاضي في التحكيم في الفقه الإسلامي

تتبين سلطة القاضي في التحكيم عند الحنفية إذا تناحصر رجلان إلى حكمين ثم رفعاً أمرهما للقاضي فإنه يقبل حكم المحكم الذي وافق رأي القاضي، ولا يقبل القاضي قول الحكم في حالة جود الخصمين إذا لم يكن هناك شهود يوافقون قول الحكم فيما حكم، كذلك أن يكون التحكيم فيما يملك المحكم إقامته بنفسه؛ فينفذ في حق الخصمين ولا يتعداها إلى غيرهما بخلاف ولاية القاضي. (السرخسي (ت: 483 هـ) دار المعرفة/1993م). وعند المالكية: ومن استهان بدعوة القاضي أو الحاكم ولم يجب يضرب أربعين. ومنها أنه ينبغي له أن يمنع من رفع الصوت عنده، فإنه يبرمه ويضجره ويحيره. (محمد عليش، أبو عبد الله المالكي (ت: 1299 هـ) دار الفكر 1989م). وقد منع الشافعية التحكيم مع وجود قاض في البلد، وقيل يجوز مع وجود قاض ويشترط الأهلية لا الاجتهاد فلا يجوز تحكيم أعمى ولا أصم ولا امرأة ولا حنثى ولا كافراً. وقيل يجوز بشرط عزم قاض بالبلد للضرورة. (الخطيب الشربيني الشافعي (ت: 977 هـ) دار الكتب العلمية 1994م). قال الحنابلة: يجوز للخصم التراجع عن حكم المحكم، ويحكم القاضي قبل أن يصل إلى مجلس الحكم. وفيه بيان أن للقاضي أن يتدخل في الأحكام ويلغونها إذا رفع أحد المتخاصمين الأمر إليه قبل أن يشرع المحكم فيه حكمه. (ابن عثيمين، ت: 1421 هـ) وتطبيقاته في المنازعات كثيرة، وأشهر هذه التطبيقات ما كان من الفاروق عمر- بشأن انتزاع ملكية دار العباس بن عبد المطلب للمصلحة العامة، وهي توسعة المسجد النبوي - على صاحبه أفضل الصلاة وأتم التسليم - واحتكاماً عند أبي بن كعب رضي الله عنهم. قال: وإني أرى أن عباساً رضي الله عنه أحق بداره حتى يرضيه. قال العباس رضي الله عنه: فإن قضيت، فإني أجعلها صدقة على المسلمين. (عبد الرزاق الصنعلي (ت: 211 هـ) تحق: الأعظمي، 1403).

واستنبط العلماء من هذه الرواية في مجملها أن "التحكيم" جاء بعد إنذار أو ما يشبهه من عمر للعباس رضي الله عنهما بانتزاع ملكية الدار استجابة للمصلحة العامة التي تعينت بالضرورة لحاجة المسلمين، وقد كثروا إلى توسيع المسجد النبوي، وأن التحكيم كان نتيجة للتراضي بينهما، وهذا يعني أن عمر لم يتزحزح عن مبدأ حق الإمام في انتزاع الملك للمصلحة العامة أو للضرورة، وإن رضي قبل تطبيقه بالتحكيم ما زال عند حكم الحكم احتراماً للحكم أو للعباس أو لهما معاً وللصحابية الذين شهدوا بصحة رواية أبي، أو على أمل أن يتراجع العباس عن تصلبه إذ أدرك عمر - من قبله أو اقتراحه التحكيم أن تصلبه ذلك إنما كان مصدره إياء العباس من أن يفرض عليه أمر، وإصراره على أن لا يتأمر عليه أحد وعلى أن تكون له الكلمة العليا فيما يتصل بشؤونه الخاصة أو ما يراه متصلاً بشؤونه الخاصة. (محمد الحاج ناصر، مجلة مجمع الفقه الإسلامي 1265/4). وبناء على ما تقدم يمكن القول بأنه: إذا كان التحكيم مؤقتاً انتهت ولاية الحكم بمرور الوقت المحدد دون أن يصدر حكمه فإذا حكم الخصوم رجلاً على أن يقضي بينهم في شهر كذا أو يوم كذا فإذا مضى الشهر أو اليوم المحدد دون أن يصدر حكمه انتهت ولايته ولا يكون له نظر النزاع إلا بتجديد التولية. (مجلة الأحكام العدلية، لجنة من عدة علماء وفقهاء في الخلافة العثمانية، تحق: نجيب هوايني، وآخرون).

ثانياً: سلطة القاضي في التحكيم في القانون الإماراتي

سأتناول هذا المطلب من خلال ثلاثة نقاط هي: التحكيم خارج المحكمة، التحكيم داخل المحكمة، ثم بيان سلطة القاضي في تنفيذ الأحكام التحكيمية في دولة الإمارات العربية المتحدة.

النقطة الأولى: التحكيم خارج المحكمة: وهو ما يسمى بالتحكيم الخاص:

جاء في تعريف التحكيم خارج المحكمة أو التحكيم الخصوصي بأنه: "احتكام الطرفين إلى شخص أو أكثر بدون أن يكون لهما دعوى في المحكمة؛ فينظمان صك التحكيم ويسجلانه عند كاتب العدل، أو يوقعانه دون تسجيل ويسلمانه إلى المحكم المنتخب، ويجوز أن يحفظ كل منهما نسخة عنه". (محمد شعبان سيد، 2014م).

النقطة الثانية: التحكيم داخل المحكمة (التحكيم القضائي):

التحكيم الذي يكون عن طريق المحكمة يكون بقرار منها (بناء على اتفاق الخصوم) إذا كان النزاع مطروحا عليها، بخلاف التحكيم الذي لم يكن النزاع مطروحا عليها. (الشوربجي 2014م)

جاء في المادة (7) "إذا تم الاتفاق على التحكيم أثناء نظر النزاع من قبل المحكمة المختصة بنظره تصدر المحكمة حكمها بإثبات اتفاق التحكيم ويترك للخصوم مباشرة إجراءات التحكيم في المكان والوقت الذي يتم تحديده وبالشروط التي تحكمه والقضاء باعتبار الدعوى كأن لم تكن". وجاء في المادة (8) "كما يجب على المحكمة التي يرفع إليها نزاع يوجد بشأنه اتفاق تحكيم أن تحكم بعدم قبول الدعوى إذا دفع المدعي عليه بذلك قبل إيداعه أي طلب أو دفع في موضوع الدعوى وذلك ما لم يثبت للمحكمة أن الاتفاق على التحكيم باطل أو يستحيل تنفيذه (قانون اتحادي لسنة 2018 بشأن التحكيم).

جاء في المادة (13) أنه إذا أخل أحد الاطراف باجراءات اختيار المحكمينتولت المحكمة بناء على طلب أحد الأطراف القيام بالاجراء المطلوب ما لم ينص الاتفاق على وسيلة أخرى لإتمام هذا الاجراء، ولا يقبل الطعن على ذلك القرار بأي طريق من طرق الطعن. ويقصد بها المحكمة المختصة مكانيا و نوعيا وقيمتيا بنظر النزاع محل التحكيم والتي كان أطرافها سيلجئون إليها أصلا لولا وجود شرط التحكيم .. (الشوربيجي، 2014م)

النقطة الثالثة : سلطة القاضي في تنفيذ الأحكام التحكيمية :
وقد وضعت دولة الإمارات موادا في قانونها الإتحادي رقم (6) لسنة 2018 م بشأن التحكيم من خلال هذه المواد ظهرت سلطة القاضي في أمور عدة منها :

- جاء في استقلالية اتفاق التحكيم في المادة (6) (7): " يكون اتفاق التحكيم مستقلا عن الشروط الأخرى ولا يترتب على بطلان العقد أو فسخه أو إنهائه أي أثر على اتفاق التحكيم الذي يتضمنه إذا كان هذا الاتفاق صحيحا في ذاته إلا تعلق الأمر بنقصان أهلية أحد المتعاقدين ". وجاء أيضا في الفصل في النزاع المتضمن اتفاق التحكيم " يجب على المحكمة التي يرفع إليه نزاع يوجد بشأنه اتفاق تحكيم أن تحكم بعدم قبول الدعوى إذا دفع المدعى عليه بذلك قبل إيدائه أي طلب أو دفع في موضوع الدعوى وذلك ما لم يتبين للمحكمة أن الاتفاق على التحكيم باطل أو يستحيل تنفيذه".
- جاء في كتابة اتفاق التحكيم في المادة (7) : " إذا تم الاتفاق على التحكيم أثناء نظر النزاع من قبل المحكمة المختصة بنظره تصدر المحكمة حكما بإثبات اتفاق التحكيم ويترك للخصوم مباشرة إجراءات التحكيم في المكان والوقت الذي يتم تحديده وبالشروط التي تحكمه والقضاء باعتبار الدعوى كأن لم تكن".

جاء في المادة (11) في كيفية اختيار هيئة التحكيم: " في الأحوال التي لا تعين فيها الجهة المفوضة المحكم وفقا للإجراءات التي يحددها اتفاق الأطراف أو وفق أحكام هذا القانون في حال عدم وجود اتفاق؛ فيجوز لأي من الأطراف أن يطلب من المحكمة أن تتخذ الإجراءات اللازمة لإتمام تشكيل وتعيين أعضاء هيئة التحكيم ويكون قرار المحكمة في هذا الشأن غير قابل للطعن عليه بأي طريق من طرق الطعن، كما يجوز للمحكمة بناء على طلب أحد الأطراف أن تطلب من أي مؤسسة تحكيم في الدولة تزويدها بقامة من المختصين في مجال التحكيم لتعيين المحكمة أحدهم".

الفصل في النزاع المتضمن اتفاق التحكيم: جاء في المادة (8) يجب على المحكمة التي يرفع إليها نزاع يوجد بشأنه اتفاق التحكيم أن تحكم بعدم قبول الدعوى إذا دفع المدعى عليه بذلك قبل إيدائه أي طلب أو دفع في موضوع الدعوى وذلك ما لم يتبين للمحكمة أن الاتفاق على التحكيم باطل أو يستحيل تنفيذه.

جاء في المادة (39) الأحكام الوقتية والجزئية: " الأحكام الوقتية لهيئة التحكيم قابلة للتنفيذ أمام المحاكم ويكون تنفيذها بموجب أمر على عريضة صادر من رئيس المحكمة أو من يفوضه بذلك".

الاخلال بإجراءات اختيار هيئة التحكيم: فقد جاء في المادة (13) أنه إذا أخل أحد الأطراف بإجراءات اختيار المحكمين ... تولت المحكمة بناء على طلب أحد الأطراف القيام بالاجراء المطلوب ما لم ينص الاتفاق على وسيلة أخرى لإتمام هذا الاجراء ولا يقبل الطعن على ذلك القرار بأي طريق من طرق الطعن.

الاختصاص العام بنظر تدابير التحكيم: فقد جاء في المادة (18) أنه: " لرئيس المحكمة أن يأمر بناء على طلب أحد الأطراف أو بناء على طلب هيئة التحكيم باتخاذ تدابير مؤقتة أو تحفظية - وفقا لما يراه ضروريا- لإجراءات التحكيم القائمة أو المحتملة سواء قبل البدء في اجراءات التحكيم أو أثناء سير تلك الاجراءات، وهذا الامر لا ينتهي كليا أو جزئيا الا بقرار يصدر من رئيس المحكمة".

عقد الجلسات وتقديم البيينة: جاء في المادة (33): تتمتع هيئة التحكيم بسلطة تقديرية لتحديد قواعد الإثبات الواجبة الاتباع ومدى قبول وارتباط أو تقدير البيينة التي يقدمها أي من الأطراف حول واقعة أو رأي الخبرة ولها كذلك أن تحدد الوقت والطريقة والصيغة التي يتم فيها تبادل مثل هذه البيينة بين الأطراف وكيفية تقديمها إلى البيينة.

صلاحية المحكمة في الأمر بتقديم أدلة الإثبات: فقد جاء في المادة (36) انه: "الهيئة التحكيم من تلقاء نفسها أو بناء على طلب أحد الأطراف أن تطلب المساعدة من المحكمة للحصول على أية أدلة، وللمحكمة في حدود سلطتها أن تأمر بتنفيذ الطلب وبحضور الشهود أمام هيئة التحكيم وذلك لتقديم والإدلاء بالشهادة الشفوية أو لإبراز المستندات .. ولرئيس المحكمة أن يقرر ما يأتي:

الحكم علي من يتهلف من الشهود أو يمتنع بغير مبرر قانوني عن الاجابة بالجزاءات المقررة في القوانين النافذة في الدولة أو يقرر رئيس المحكمة بالحكم بتكليف الغير بإبراز مستند تحت حوزته يكون ضروريا للحكم في النزاع أو الأمر بالنيابة القضائية".

الأحكام الوقتية والجزئية: جاء في المادة (39) " الاحكام الوقتية والجزئية لهيئة التحكيم قابلة للتنفيذ أمام المحاكم ويكون تنفيذها بموجب أمر على عريضة صادر من رئيس المحكمة أو من يفوضه بذلك".

ميعاد إصدار الحكم المنهي للخصومة: جاء في المادة (42) " يجوز لهيئة التحكيم أو لأي من الأطراف ...أن تطلب من المحكمة اصدار قرار بتحديد ميعاد اضافي لإصدار حكم التحكيم أو انتهاء اجراءات التحكيم اذا اقتضت الضرورة ذلك".

الفصل في المسائل الأولية: جاء في المادة (43) إذا عرضت إجراءات التحكيم مسألة تخرج عن ولاية هيئة التحكيم أو طعن بالتزوير في برقة قدمت إليها أو اتخذت إجراءات جزائية عن تزويرها أو عن أي جريمة أخرى فلهيئة التحكيم الاستمرار في نظر موضوع النزاع إذ رأت أن الفصل في هذه المسألة أو تزوير لورقة أو في الفعل الجزائي الآخر ليس لازمة للفصل في موضوع النزاع وإلا فعليها التحكيم ويعود احتسابه ثانية من اليوم التالي لتاريخ إبلاغ هيئة التحكيم بزوال مهيب الوفاء **مصروفات التحكيم:** جاء في المادة (46) " للمحكمة أن تقرر بناء على طلب أحد الأطراف تعديل تقدير المحكمين لتعابهم أو المصاريف بما يتناسب مع الجهد المبذول وطبيعة النزاع وخبرات المحكم، ولا يجوز تقديم أية طلبات للمحكمة لإعادة النظر في مقدار المصاريف ذلك حالة وجود اتفاق على تحديدها".

القوة الإلزامية لحكم التحكيم: جاء في المادة (52) "يعتبر حكم التحكيم الصادر وفقا لأحكام هذا القانون ملزما للأطراف ويحوز حجية الأمر المفضي ويكون له ذات القوة التنفيذية كما لو كان حكما قضائيا إلا أنه يشترط لتنفيذه الحصول على قرار المصادقة عليه من المحكمة".

الاعتراض على حكم التحكيم: جاء في المادة (53) لا يقبل الاعتراض على حكم التحكيم إلا بموجب رفع دعوى بطلان إلى المحكمة أو أثناء نظر طلب المصادقة على الحكم ... أيضاً تحكم المحكمة ببطلان حكم التحكيم من تلقاء نفسها إذا وجدت أن موضوع النزاع يعد من المسائل التي لا يجوز فيها التحكيم أو خالف حكم التحكيم النظام العام والآداب العامة بالدولة".

دعوى بطلان حكم التحكيم: جاء في المادة (54) أنه " يعتبر الحكم الصادر من المحكمة في دعوى البطلان نهائيا لا يقبل الطعن إلا بالنقض، ولا تسع دعوى البطلان بعد مرور (30) ... كذلك للمحكمة التي يطلب منها إبطال حكم التحكيم أن توقف اجراءات الإبطال لمدة لا تزيد عن (60) يوما إذا وجدت ذلك ملائما بناء على طلب من أحد الأطراف، من أجل منح هيئة التحكيم فرصة لاتخاذ أي إجراء أو تعديل في شكل الحكم من شأنه إزالة أسباب الإبطال دون أن يؤثر على مضمونه".

تنفيذ حكم التحكيم: جاء في المادة (55) أنه " يتعين على من يرغب في تنفيذ حكم التحكيم أن يتقدم بطلب المصادقة على حكم التحكيم والأمر بتنفيذه إلى رئيس المحكمة".

● **وقف تنفيذ حكم المحكم:** جاء في المادة (56) أنه " لا يترتب على رفع دعوى بطلان حكم التحكيم وقف تنفيذ حكم التحكيم ومع ذلك يجوز للمحكمة التي تنظر دعوى بطلان حكم التحكيم أن تأمر بوقف التنفيذ بناء على طلب أحد الأطراف إذا كان الطلب مبنياً على أسباب جدية... كذلك ورد إذا قررت المحكمة وقف التنفيذ جاز لها أن تأمر طالب الوقف بتقديم كفالة أو ضمان مالي ... "

التوصيات

منعاً للتنازع أو وصي بالزام المصارف أن تسلك مسلك الوضوح والبيان في الرسوم التي تتقاضاها مقابل العقود التي تقيمها وتذكر الرسوم في العقد على وجه التفصيل إذ أن كثيراً من اتفاقيات المصارف تغفل جانب العمولات والرسوم فتذكرها بمجملتها مبهمه . الاستفادة من العلماء في تقرير أحكام المسائل المستجدة والنص على إلزامية القرار الصادر عنها ، ومن الدراسات الأكاديمية سواء في البنوك أو القضاء أو ما يتعلق بهما كمرآة التحكيم وغيرها . لا بد للمسؤولين السعي الحثيث لاجتثاث الربا من البلاد وتطبيق النظام الإسلامي في المعاملات المصرفية أن يكون في كل مركز تحكيم أو في اللجان التابعة للبنوك أو القضاء متخصصين شرعيين، وأصحاب خبرة بنزاعات البنوك للوصول إلى حل مرضي، ويكون هناك ميثاق للتحكيم الشرعي في مجال التحكيم المالي للعلاقات والعقود المالية بين الأفراد. التعاون والتنسيق بين مراكز التحكيم والقضاء بشكل أكثر مرونة وسهولة والتكامل بينها بما يواكب التطور الاقتصادي. إعطاء العميل في البنوك فرصة لقراءة العقود – من يوم إلى يومين – ليتمكن من قراءة الشروط والأحكام جيداً ، وليتمكن من استشارة أهل الخبرة والاختصاص قبل التوقيع على أي عقد. أن يكون هناك مكتب استشارات في مسائل العقود المصرفية بالمحاكم ليكون العميل على بصيرة قبل إجراء أي عقد . يوصى بكتابة التاريخ مع التوقيع من قبل العميل والمصرف في أن واحد بالعقود المصرفية ، وهذا يفيد القضاة وأصحاب الحق في إثبات الحق من عدمه للمنتازعين. إنشاء مركز متخصص بمنازعات الصيرفة الإسلامية يتبع المصرف المركزي يضم المتخصصين في المجالات القانونية والشرعية والمالية.

المصادر والمراجع

- اتفاق التحكيم في ضوء أحكام القضاء الإماراتي ومشروع القانون الاتحادي في شأن التحكيم في المنازعات التجارية ، د. الشهابي إبراهيم الشهابي الشرفوي – سلسلة علمية محكمة – معهد دبي القضائي ، ط 1، 2013م/ 1433هـ .
- اجتهادات قضاء تمييز دبي في المعاملات 1988-2006م ، د. عوض الحسن النور ، قاضي المحكمة العليا القومية بالسودان والمعار بمحاكم دبي ، مكتبة المستقبل / دبي ، 2006م. اشتراط التحكيم أو التحاكم إلى قنون وضعي في عقود المؤسسات المالية ، المجمع الفقهي الإسلامي ، الشيخ عجيل جاسم التشمي ، الدورة العشرون ، مكة المكرمة ، 1432 هـ – 2010 م.
- أعمال البنوك في ضوء أحكام محكمة النقض من سنة 2008 إلى 2010 ، إمارة أبوظبي – دائرة القضاء .
- الإصناف في معرفة الراجح من الخلاف، علي بن سليمان المرادوي الحنبلي لعلاء الدين أبو الحسن (ت: 885هـ) دار إحياء التراث العربي ، ط 2- بدون تاريخ .
- بحث الإسلام وانتزاع الملك للمصلحة العامة، إعداد فضيلة الشيخ محمد الحاج ناصر، مجلة مجمع الفقه الإسلامي.
- بدائع الصنائع في ترتيب الشرائع، أبو بكر بن مسعود بن أحمد الكلساني (ت: 587هـ) دار الكتب العلمية، ط 2، 1406هـ - 1986م.
- التاج والإكليل لمختصر خليل، محمد بن يوسف بن أبي القاسم بن يوسف العبدري الغرناطي، أبو عبد الله المالك (ت: 897هـ) دار الكتب العلمية، ط 1، 1416هـ/ 1994م.
- التحكيم في العمليات المصرفية في النول ذات الاقتصاد المتحول، د. موسى خليل مزي ، د. أيوب ميلة ، كلية الحقوق – جامعة دمشق، 2010م.
- التحكيم في المنازعات المصرفية الإسلامية ، دراسة فقهية – قانونية ، رسالة ماجستير ، إعداد : عبدالسلام جنوبي ، إشراف أ. د. محمد بوزغية ، جامعة الزيتونة ، المعهد العالي لأصول الدين، 1437 هـ / 2016م.
- التحكيم في المنازعات المصرفية في السودان، (دراسة تأصيلية مقارنة بحث لنيل درجة الدكتوراه في القانون)، جامعة الرباط الوطني ، إعداد الطالب: عاصم محمد علي سيد أحمد، مارس 2017 م جمدي الثاني 1438 هـ .
- التحكيم في منازعات العمليات المصرفية الإسلامية في القانون الليبي الواقع والأفاق، إعداد: عز الدين أبو بكر علي، المحاضر بكلية القانون، جامعة عمر المختار ليبيا. June 16-15 2010 .
<http://iepedia.com/arab/2010>
- التحكيم كإلية لفض المنازعات ، المستشار / د. سمير جاويد، دائرة القضاء-أبوظبي ، ط 1، 2014م.
- التحكيم كوسيلة لتسوية المنازعات في العقود الدولية ، محمد شعبان سيد، دار النشر : المنهال ، 2014 م.
- التحكيم ومستجداته في ضوء الفقه الإسلامي ، محمد الألفي ، أبحاث اليرموك ، سلسلة العلوم الإنسانية والاجتماعية ، مجلة علمية فصلية محكمة مفهومة ، المجلد 13 ، العدد الرابع ، 1418- 1997م
- تسوية المنازعات المصرفية في المملكة العربية السعودية ، صالح بن علي بن صالح الصويح ، إشراف د. محمد بن ناصر البجاد ، رسالة ماجستير في العدالة الجنائية ، 1431 هـ / 2010 م.
- تهذيب اللغة ، محمد بن أحمد بن الأزهر الهروي، أبو منصور (ت: 370هـ) تحقق: محمد عوض مرعب، دار إحياء التراث العربي – بيروت، ط 1، 2001م.
- جريمة الربا في الشرع والقانون – القانون الإماراتي، محمد المرزوقي للمحاماة والاستشارات القانونية 2018م ، <https://blog.ml-advocates.com> ،
- الجوهر النيرة ، أبو بكر بن علي الحدادي العبادي الزبيدي الحنفي (ت: 800هـ) المطبعة الخيرية، ط 1، 1322 هـ .
- حاشية الصاوي ، أبو العباس أحمد بن محمد الخلوئي، الشهير بالصاوي المالك (ت: 1241 هـ) دار المعارف، بدون طبعة وبدون تاريخ.
- الحاوي الكبير في فقه مذهب الإمام الشافعي، علي بن محمد بن حبيب الماوردي، (ت: 450هـ) تحقق: علي محمد معوض وعادل أحمد عبد الموجود، ط 1، دار الكتب العلمية، بيروت – لبنان، 1419هـ/ 1999م.
- الدليل الإرشادي للحلول البديلة لفض النزاعات ، المستشار البشري محمد الشوريجي، دائرة القضاء ، ط 1، 2014م.
- الذخيرة ، أحمد بن إدريس المالكي، أبي العباس شهاب الدين الشهير القرافي (ت 684 هـ) تحقق: سعيد أعرب ، ط 1، دار الغرب الإسلامي ببيروت ، 1994م.
- الذخيرة ، أحمد بن إدريس المالكي، أبي العباس شهاب الدين الشهير القرافي (ت 684 هـ) تحقق: سعيد أعرب ، ط 1، دار الغرب الإسلامي ببيروت، 1994م.
- رد المختار على الدر المختار ، ابن عابدين، محمد أمين بن عمر بن عبد العزيز دمشقي الحنفي (ت: 1252هـ) دار الفكر ببيروت، ط 2، 1412 هـ / 1992م.
- روضة الطالبين وعمدة المتقين، يحيى بن شرف بن حري النووي (ت: 676هـ) ط 3، المكتب الإسلامي، بيروت – لبنان، 1412 هـ/ 1992م .
- الشرح المتعمق على زاد المستقنع، محمد بن صالح بن محمد العثيمين (ت: 1421 هـ) دار ابن الجوزي، ط 1، 1422 – 1428هـ .
- العمليات المصرفية في قنون وقضاء دولة الإمارات العربية المتحدة ، دراسة مقارنة، د. عبدالله حسن محمد ، جامعة الإمارات العربية المتحدة، ط 1، 2001م – 1422 هـ .
- قنون تحكدي رقم (6) لسنة 2018 بشأن التحكيم.
- قضاء تمييز دبي التجاري ، المبادئ التي قررتها محكمة التمييز بدبي في أحد عشر عاما 1988-1999م ، المستشار محمد هاني اسماعيل : نائب رئيس الاستئناف بالقاهرة والمعار بمحاكم دبي.
- قضاء تمييز دبي في دعاوي البنوك مجموعة القواعد القانونية والأحكام الصادرة عن محكمة تمييز دبي ، إعداد المستشار / قتيبة محمود قره ، محاكم دبي ، 2012م.
- المبدع شرح المقنع، محمد بن عبد الله بن محمد بن مفلح المقدسي (ت: 884هـ) ، بدون الطبعة، المكتب الإسلامي، دمشق، سوريا، 1394هـ/ 1974م.
- الميسوط ، شمس الدين السرخسي (ت: 483 هـ) دار المعرفة، بيروت – لبنان ، 1414 هـ/ 1993م .
- من بداية المبتدي في فقه الإمام أبي حنيفة، علي بن أبي بكر بن عبد الجليل الفرغاني المرغيني، أبو الحسن برهان الدين (ت: 593هـ) مكتبة ومطبعة محمد علي صبح – القاهرة .
- مجلة الأحكام العدلية، لجنة مكونة من عدة علماء وفقهاء في الخلافة العثمانية، تحقق: نجيب هواويني، نور محمد، كارخانه تجار كنب، آرام باغ، كراتشي، التحكيم في ضوء أحكام الشريعة الإسلامية.

- مجلة مجمع الفقه الإسلامي بجهة، 1711/9 ، تصدر عن مجمع الفقه الإسلامي التابع لمنظمة المؤتمر الإسلامي، الدورة التاسعة، لمجلس المجمع بمدينة أبو ظبي في الفترة ما بين 1- 6 ذي القعدة 1415 هـ (1- 6 إبريل/ نيسان 1995م) .
- المجموع شرح المهذب بحج بن شرف النووي، أبو زكريا (ت: 676 هـ) ، تحق: محمد نجيب المطيعي، دار الفكر = مكتبة الإرشاد ، المملكة العربية السعودية. مجموعة القواعد والأحكام الصادرة عن محكمة تمييز دبي في التسييلات المصرفية من 1991 إلى 2010م، إعداد: المكتبة القانونية ، 2015م، بدون طبعة. المصنف، أبو بكر عبد الرزاق بن همام بن نافع الحميري اليمني الصنعائي (المتوفى: 211 هـ) تحق: حبيب الرحمن الأعظمي، المجلس العلمي- الهند، المكتب الإسلامي – بيروت، ط2، 1403 .
- معجم اللغة العربية المعاصرة ، د أحمد مختار عبد الحميد عمر (ت: 1424 هـ) بمساعدة فريق عمل ، عالم الكتب ط1، 1429 هـ / 2008 م. معني المحتاج إلى معرفة معاني ألفاظ المنهاج ، شمس الدين، محمد بن أحمد الخطيب الشربيني الشافعي (ت: 977 هـ) دار الكتب العلمية، ط1، 1415 هـ / 1994م. منح الجليل شرح مختصر خليل، محمد بن أحمد بن محمد عيش، أبو عبد الله المالكي (ت: 1299 هـ) دار الفكر – بيروت، بدون طبعة، 1409 هـ/ 1989م. التنف في القنوى، أبو الحسن علي بن الحسين بن محمد السُّعدي، حنفي (المتوفى: 461 هـ)، المحامي الدكتور صلاح الدين الناهي ، دار الفرقان / مؤسسة الرسالة - عمان الأردن / بيروت لبنان ، ط2، 1404 – 1984م
- التَّوَادِر وَالزِّيَادَات عَلَى مَا فِي الْمَدُونَةِ مِنْ غَيْرِهَا مِنَ الْأَمْهَات، أبو محمد عبد الله بن (أبي زيد) عبد الرحمن النفزي، القيرواني، المالكي (المتوفى: 386 هـ) ، تحق: د القَّاح محمد الحلوب محمَّد حجي، الأستاذ/ محمد عبد العزيز الدباغ، د. عبد الله المرابط الترغي، محمد الأمين بوخيزة ، د. أحمد الخطابي، دار الغرب الإسلامي، بيروت، ط1، 1999م.

THE SOCIAL SOLIDARITY AND ITS ROLE DURING CORONAVIRUS

Mohammad Golamur Rahman

التكافل الاجتماعي ودوره في زمن كورونا

Sultan Zainal Abidin University (UniSZA), Malaysia

ملخص البحث:

التكافل الاجتماعي من أهم الأسس التي يقوم عليها المجتمع في الإسلام، والتي تضمن سعادته وبقائه في إطار من المودة والأمن والوحدة والسلام. والتكافل الاجتماعي في مظهره وجوهره يهدف إلى تكريم الإنسان والسمو في المستوى الأخلاقي والسلوكي، كما أنه يخلق في الوسط الاجتماعي الأمن والمحبة، ويزيل الضغائن والأحقاد بين الأغنياء والفقراء والحكام. ويهدف هذا البحث إلى كشف أهمية التكافل الاجتماعي ودوره في تقوية الروابط الاجتماعية في زمن كورونا مع الوقوف على مفهوم التكافل الاجتماعي في ضوء الفكر الإسلامي، بالإضافة إلى بيان مظاهر التكافل الاجتماعي في ضوء القرآن الكريم والسنة النبوية. وقد توصلت إلى أن التكافل الاجتماعي لا يقتصر على النفع المادي فقط، بل يتجاوز إلى حاجات المجتمع المعنوية. وأبلغ صورة للتكافل الاجتماعي في الإسلام هو استقبال الأنصار للمهاجرين عندما هاجر النبي صلى الله عليه وسلم من مكة المكرمة إلى المدينة المنورة.

الكلمات المفتاحية: التكافل، الاجتماعي، كورونا.

مقدمة البحث

الحمد لله رب العالمين، والعاقبة للمتقين، والصلاة والسلام على رسوله الكريم، وعلى آله وأصحابه ومن تبعهم بإحسان إلى يوم الدين. أما بعد: فإن المجتمع المسلم هو الذي يطبق فيه الإسلام عقيدة وعبادة وشريعة ونظاماً وخلقاً وسلوكاً وفقاً لما جاء به الذكر الحكيم والسنة النبوية المطهرة، حتى يكون المجتمع الذي رسم لنا صورته الرسول صلى الله عليه وسلم باعتباره الجسد الواحد أو البنين المرصوص الذي يشد بعضه بعضاً.

فهذا البنين لا يمكنه الشموخ إلا إذا اعتمد أفراد المجتمع على إقرار مبدأ التكافل وتفعيله فيكونون متضامنين مع بعض، متشاركين في جلب المصالح العامة ودرء المفاسد والأضرار بكل أنواعها، بحيث يشعر كل فرد أنه - إلى جانب حقوقه التي هي له - عليه واجبات تجاه الآخرين خاصة الذين ليس بمقدورهم أن يلبوا حاجاتهم الضرورية سواء كانت مادية أو معنوية.

فالتكافل لا يعني فقط الشعور بالتعاطف والوقوف عند هذا الحد ولكن يجب أن يصاحبه الفعل الإيجابي. أكد العلماء أن التكافل الاجتماعي ينقسم قسمين: قسماً مادياً وقسماً معنوياً. فالقسم المادي هو المساعدة المادية بالأموال كي ينقل المحتاج من حالة الفقر إلى حد الكفاية أو حد الغنى. وأما التكافل المعنوي: فيأتي في صور أخرى كثيرة لأن احتياج الإنسان لا يقتصر فقط على الاحتياجات المادية، ولكنه يتضمن أشكالاً أخرى مثل: النصيحة، الصداقة، الود، التعليم، الموساة في الأحران، وغيرها الكثير من أشكال العطاء.

وأبلغ صورة للتكافل الاجتماعي في الإسلام هو استقبال الأنصار للمهاجرين عند هجرة الرسول الأكرم صلى الله عليه وسلم متقاسمين معهم ديارهم ولباسهم ورزقهم، متضامنين معهم مادياً ومعنوياً لنشر الدعوة الإسلامية فكان المجتمع الإسلامي آنذاك مجتمعاً نموذجياً مثالياً.

وهذا البحث يهدف إلى كشف أهمية التكافل الاجتماعي في تقوية الروابط الاجتماعية في ضوء الفكر الإسلامي مع بيان مفهوم التكافل الاجتماعي في ضوء القرآن الكريم والسنة النبوية، بالإضافة إلى بيان دور التكافل الاجتماعي في زمن كورونا. وقد اشتمل البحث على مقدمة وأربعة مطالب وختمته:

المطلب الأول: مفهوم التكافل الاجتماعي

المطلب الثاني: التكافل الاجتماعي في القرآن والسنة

المطلب الثالث: ثمار التكافل الاجتماعي في الفكر الإسلامي

المطلب الرابع: دور التكافل الاجتماعي في زمن كورونا

وفي الخاتمة ذكر الباحث أهم النتائج والتوصيات التي توصل إليها من خلال هذه الدراسة الجيزة، ثم أتبع الخاتمة بقائمة المصادر والمراجع التي اعتمد عليها في القيام بأعداد البحث. والله الموفق والمعين.

المطلب الأول: مفهوم التكافل الاجتماعي

إن شريعة الإسلام تقرض على المسلمين أن يسود بينهم التعاون والتآزر والتكافل في الحاجات والماديات، وأن يكونوا كالبنين المرصوص كما قال رسولنا الكريم محمد صلى الله عليه وسلم في الحديث الشريف: «المؤمن للمؤمن كالبنيان يشد بعضه بعضاً». [أخرجه البخاري].

التكافل الاجتماعي في اللغة من كفل، وكفل بمعنى عال، والكافل العائل والضامن والمنفق، يقال: كفل الصغير، أي رباة وأنفق عليه. والمعنى اللغوي للتكافل هو الانضمام، أي ضم ذمة إلى ذمة لتتقوى إحداهما بهذا الضم. أي إن كل فرد قادر من أفراد المجتمع يتعين عليه عون أخيه المحتاج حتى يضمن له على الأقل المستوى الأدنى من الحياة الكريمة، وضمان وجود الاحتياجات الأساسية، وذلك لجميع أفراد المجتمع دون التفرقة بين ديانة أو جنسية. فالتكافل لا يعني فقط الشعور بالتعاطف والوقوف عند هذا الحد ولكن يجب أن يصاحبه الفعل الإيجابي.

اختلفت وجهات نظر العلماء والباحثين للتكافل الاجتماعي في الفكر الإسلامي بين مضييق بقصره على تلبية الجانب المادي فقط، وموسع بحيث يشمل الجانب المادي والمعنوي، وهذه النظرة هي التي تتوافق مع المعنى اللغوي للتكافل الاجتماعي. ومن هذه التعريفات:

عرّفه الشيخ محمد أبو زهرة: بأنه أن يكون أحد الشعب في كفالة جماعتهم وأن يكون كل قادر أو ذو سلطة كفيلاً في مجتمعه يمدّه بالخير وأن تكون كل القوى الإنسانية في المجتمع متلاقية في المحافظة على مصالح الأحاد ودفع الأضرار ثم في المحافظة على دفع الإضرار عن البناء الاجتماعي وإقامته على أسس سليمة. [أبو زهرة: 5].

وعرّفه الشيخ شلتوت: بأنه لازم من لوازم الأخوة، بل هي أبرز لوازمها وهو شعور الجميع بمسئوليته بعضهم عن بعض وأن كل واحد منهم حامل لتبعات أخيه ومحمول على أخيه يسأل عن نفسه، ويسأل عن غيره. [محمود شلتوت: 447].

وعرّفه أيضاً: بأنه تضامن أبناء المجتمع وتساندهم فيما بينهم سواء أكانوا أفراداً أو جماعاتٍ حكماً أو محكومين على اتخاذ مواقف إيجابية كحماية البيتيم وتحريم الاحتكار بدافع من شعور وجداني عميق ينبع من أصل العقيدة الإسلامية ليعيش الفرد في كفالة الجماعة وتعيش الجماعة بمؤازرة الفرد حيث يتعاون الجميع ويتضامنون لإيجاد المجتمع الأفضل ودفع الضرر عن أفرادها. [ناصر علوان: 15].

وأن الكافل هو الجماعة والقادر وذو السلطان والقوى الإنسانية، والمكفول هو أحد الشعب وأفراد المجتمع، والحاجات المكفولة هي المحافظة على مصالح الأحاد ودفع الأضرار عنها لإيجاد المجتمع الأفضل والأمثل. وهناك تعريفات أخرى كثيرة لا تختلف في مضمونها عن التعريفات السابقة.

المطلب الثاني: التكافل في القرآن الكريم والسنة النبوية

لا ريب في أن الإسلام دين الجماعة قبل أن يكون دين الأفراد، بل الإسلام دين الإنسانية جمعاء، وإن الإسلام وضع الأنظمة والأسس الصحيحة والسليمة للتكافل الاجتماعي في القرآن والسنة. وعلى هذا فقد حفلت الشريعة الإسلامية الغراء بالكثير من النصوص التي تحت وتدعو، بل توجب التعاضد والتأزر والحفاظ على حقوق الأفراد والجماعة في المجتمعات.

أولاً: التكافل في القرآن الكريم

ولقد تحدثت العديد من الآيات القرآنية المباركة عن موضوع التكافل والتعاون بين الأفراد، لما يحقق من الوحدة والاطمئنان للفرد والمجتمع. فقد جاء في الذكر الحكيم قوله تعالى: ﴿وَتَعَاوَنُوا عَلَى الْبِرِّ وَالتَّقْوَىٰ ۖ وَلَا تَعَاوَنُوا عَلَى الْإِثْمِ وَالتَّعَدْوَانِ﴾ [المائدة: 2]. وفي آية أخرى قال تعالى: ﴿إِنَّمَا الْمُؤْمِنُونَ إِخْوَةٌ فَأَصْلِحُوا بَيْنَ أَخَوَيْكُمْ وَاتَّقُوا اللَّهَ لَعَلَّكُمْ تُرْحَمُونَ﴾ [الحجرات: 10].

والقرآن الكريم يدعو إلى التكافل الأسري لقول الله عز وجل: ﴿وَإِذْ أَخَذْنَا مِيثَاقَ بَنِي إِسْرَائِيلَ لَا تَعْبُدُونَ إِلَّا اللَّهَ وَبِأُولِي النَّيِّبِ إِحْسَانًا وَذِي الْقُرْبَىٰ وَالْيَتَامَىٰ وَالْمَسَاكِينِ وَقُولُوا لِلنَّاسِ حُسْنًا وَأَقِيمُوا الصَّلَاةَ وَآتُوا الزَّكَاةَ ثُمَّ تَوَلَّيْتُمْ إِلَّا قَلِيلًا مِّنْكُمْ وَأَنتُمْ مُّعْرِضُونَ﴾ [البقرة: 83]. وهي دعوة إلى التكافل الأسري.

ويدعو القرآن الكريم أيضاً إلى الوحدة ونبذ الفرقة والتشرذم حتى يتحقق في المجتمع التكافل ويقوي الروابط الاجتماعية لقوله عز وجل: ﴿وَاعْتَصِمُوا بِحَبْلِ اللَّهِ جَمِيعًا وَلَا تَفَرَّقُوا ۚ وَاذْكُرُوا نِعْمَتَ اللَّهِ عَلَيْكُمْ إِذْ كُنْتُمْ أَعْدَاءً فَأَلَّفَ بَيْنَ قُلُوبِكُمْ فَأَصْبَحْتُمْ بِنِعْمَتِهِ إِخْوَانًا وَكُنْتُمْ عَلَىٰ شَفَا حُفْرَةٍ مِّنَ النَّارِ فَأَنْقَذَكُمْ مِنْهَا ۚ كَذَلِكَ يُبَيِّنُ اللَّهُ لَكُمْ آيَاتِهِ لَعَلَّكُمْ تَهْتَدُونَ﴾ [آل عمران: 103]. وهي دعوة إلى الوحدة ونبذ الفرقة والتشرذم.

هذه الآيات القرآنية وغيرها تتضمن أسماً أنواع التكافل الاجتماعي في المجتمع، للقضاء على الفقر والبطالة، وفي القرآن الكريم أيضاً الكثير من الآيات التي تدعو إلى الحفاظ على الوحدة والجماعة الإسلامية.

ثانياً: التكافل في السنة النبوية المطهرة

أما في السنة النبوية المطهرة فوردت الكثير من الأحاديث التي توجب التكافل الاجتماعي بين المسلمين أفراداً وجماعة، قال رسول الله صلى الله عليه وسلم: «من كان له فضل زاد فليعد به على من لا زاد له، ومن كان له فضل ظهر فليعد على من لا ظهر له». ثم أخذ يعد أصناف من الأموال حتى ظننا أن ليس لنا من مالنا إلا ما يكفيننا. [مسلم: 665]. ويقول رسولنا الكريم صلى الله عليه وسلم: «فمن توفي من المؤمنين فترك ديناً فعلي قضاؤه، ومن ترك مالاً فلورثته». [البخاري: 369]. وهذا هو التكافل الذي يلتزم به المجتمع، ويؤديه ولي الأمر نحو الأيتام والضعفاء من الناس، حتى لا يضيعوا في الحياة. [التركي: 50].

والحديث يدل أيضاً على أن النبي صلى الله عليه وسلم باعتبارها رئيساً وقائداً للدولة الإسلامية مسؤول عن كفالة أهل البيت وعياله اجتماعياً إذا لم يكن لهم من يقوم بهم، بل إن مسؤوليته بهذا الاعتبار لا تقف عند الالتزام بهذه الكفالة بل تتعدى إلى سداد دينه، وذلك بعد ما فتح الله عليه من الفتح وكثر المال. [عبد اللطيف محمود: 149].

وورد عن رسول الله صلى الله عليه وسلم قوله: «كلكم راع، وكلكم مسؤول عن رعيته، الإمام راع وهو مسؤول عن رعيته، والرجل راع في أهله وهو مسؤول عن رعيته، والمرأة راعية في بيت زوجها وهي مسؤولة عن رعيته». [البخاري: 159]. وفي هذا الحديث دلالة على مسؤولية الإمام باعتباره رئيساً للدولة وقائداً لها أمام الله تعالى عما استتر عاه من البلاد والعباد، وهذه المسؤولية عامة تشمل الكفالة الاجتماعية لمن هم تحت ولايته، إن كان في بيت المال ما يسد حاجتهم، فيسد جوع الجائع ويكسي العاري، ويؤوي المشرّد، وهي من أزم أمور الكفالة الاجتماعية، إذ دل الحديث على إن كل من كان تحت نظره شيء، فهو مطالب بالعدل فيه، والقيام بمصالحه في دينه ودنياه ومتعلقاته. [عبد اللطيف محمود: 148].

وطبق رسول الله صلى الله عليه وسلم مبدأ التكافل الاجتماعي على أرض الواقع في أبهى صورة، وأشرف مقصد حين أخی بين المسلمين مرة، وأخی بين المهاجرين والأنصار مرة أخرى ليجسد لنا روح الإسلام في أروع المعاني، وأدل الصور حين لم يكن للدولة خزينة أو بيت مال ينفق منه على من يستحق النفقة، فكان المسلمون كالبنیان المرصوص يشد بعضهم بعضاً.

ثالثاً: التكافل في السيرة النبوية

كان من أولى الخطوات التي اتخذها رسول الله صلى الله عليه وسلم بعد هجرته إلى يثرب أن أخی بين المهاجرين والأنصار، في المجتمع الجديد ليصهر المسلمون في بونقة واحدة، وللقضاء على الفوارق الاجتماعية التي نتجت عن هجرة المسلمين من مكة بعد أن تركوا ديارهم وأموالهم. وقال ابن سعد: لما قدم رسول الله صلى الله عليه وسلم المدينة أخی بين المهاجرين وبعضهم لبعض، وأخی بين المهاجرين والأنصار، أخی بينهم على الحق والمواساة ويتوارثون بعد الممات دون ذوي الأرحام، أي إن التكافل الاجتماعي وصل إلى أرقى صورة، وأعلى مرحلة، وأكمل وجه بأن جعل المسلم أخی المسلم، وإن بعد عنه بالنسب، فإنه يرثه دون أخيه الصليبي. [لز هري: 204].

وصورة أخرى للتكافل الاجتماعي يطبقها رسول الله صلى الله عليه وسلم هي صورة ولي الأمر الذي يحمل هموم عبته في وجدانه، ويسهر على تحقيق الأمن الاجتماعي، وتوفير المستقبل الآمن لهم، وذلك حين أفاء الله تعالى أموال بني النضير سنة (4هـ)، وكانت هذه الأموال خالصة لرسول الله صلى الله عليه وسلم دون الناس، فأثمه صلى الله عليه وسلم لم يستأثر بها لنفسه، أو لأهل بيته، وفي المسلمين من لا يجد لقمة العيش، أو المأوى، وفيهم من يشارك الأناصر مساكنهم، لم يستأثر رسول الله صلى الله عليه وسلم بهذه الأموال كي يضرب لنا مثلاً رائعا في كون الحاكم أو ولي الأمر متحسناً للأمامة لا يؤثر على مصلحة الرعية شيئاً، وإن غلا، فقسّم رسول الله صلى الله عليه وسلم هذه الأموال على المهاجرين، ولم يعط منها شيئاً للأناصر إلا رجلين شكوا حاجتهما، هما أبو دجانة وسهل ابن حنيف. [رحيم علي: 520-521].

هذه الرواية توضح لنا دور ولي الأمر في تحقيق التكافل الاجتماعي، وأن رسول الله صلى الله عليه وسلم كان قدوة حسنة، ومثالا للراعي المؤمن على رعيته، فقسّم فيهم ما خصه الله، وحباه بهذه الأموال، فأعطى المهاجرين، ولم ينس الأناصر، فطيب خاطرهم رغم عدم حاجتهم لها، ورغم أنها كانت خالصة له يضعها حيث يشاء، كما ترشدنا هذه الرواية إلى تلك الأخلاق الحميدة التي يتمتع بها الأناصر، والى روح التكافل، والتضامن التي كانت تسود المجتمع؛ إذ إنهم لبوا رغبة رسول الله صلى الله عليه وسلم بل إنهم دعوا رسول الله صلى الله عليه وسلم إلى أن يقسم أموال بني النضير بين المهاجرين، ويبقى المهاجرون على سكنهم مع الأناصر.

المطلب الثالث: ثمار التكافل الاجتماعي وأهميته في الفكر الإسلامي

ولقد عني الإسلام بالتكافل الاجتماعي عناية فائقة؛ لما يحتويه من فوائد جمّة تعود بالنفع على الفرد والمجتمع، ومن أهمّ هذه الحلول ما يلي:

أولاً: النيل والوصول إلى رضا الله عزّ وجلّ

إنّ التكافل الاجتماعي في الإسلام أصيلٌ في إنسانيته، عام في فطرته، باز في تطبيقه، عميق في دوافعه، فطريّ النزعة، يستمد مقوماته من الإيمان بالله تعالى والثقة فيه، وأن غايته رضي الله. [عبيد منصور: 70].

وكيف لا يكون فيه مرضاة الله تعالى وهو يسعى إلى تفرّج الكرب والهموم عن الغير، فعن أبي هريرة أن النبي صلى الله عليه وسلم قال: «من نفس كربة من كرب المسلم في الدنيا نفس الله عزّ وجلّ عنه كربة من كرب الآخرة ومن ستر عورة مسلم ستر الله عورته في الدنيا والآخرة والله عزّ وجلّ في عون العبد ما كان العبد في عون أخيه». [الطبراني: 240/7]. وأن من أحب الأعمال إلى الله تعالى هو إدخال السرور إلى المسلم.

ثانياً: استيضاح الأصل الواحد في المواساة والتعاون

إنّ التكافل صفة كاملة لصور كثيرة من التآزر والتعاون والمشاركة في سدّ الثغرات، تتمثل بتقديم العون والحماية والنصرة والمواساة إلى أن تقضى حاجة المضطر، وبزول هم الحزين، ويندمل جرح المصاب. [محمود محمد: 173].

إنّ الإسلام لم يقف عند الحفاظ على المسلم فحسب، بل دعا إلى أن يشمل هذا التكافل كل فرد من أفراد المجتمع أياً كان، مسلماً أو كافراً، وأن الله ليذكر بأننا من أصل واحد. [أحمد عيده: 99]. فقال تعالى: ﴿يَا أَيُّهَا النَّاسُ اتَّقُوا رَبَّكُمُ الَّذِي خَلَقَكُمْ مِنْ نَفْسٍ وَاحِدَةٍ وَخَلَقَ مِنْهَا زَوْجَهَا وَبَثَّ مِنْهُمَا رِجَالًا كَثِيرًا وَنِسَاءً وَاتَّقُوا اللَّهَ الَّذِي تَسَاءَلُونَ بِهِ وَالْأَرْحَامَ إِنَّ اللَّهَ كَانَ عَلَيْكُمْ رَقِيبًا﴾ [النساء: 1]. وبالتالي فإنّ التكافل الاجتماعي لا يقتصر على المسلمين فحسب، بل يمتد ليشمل بمطلقه كل من يعيش في الدولة الإسلامية مسلماً كان أم غير مسلم.

ثالثاً: التمسك والافتداء بالدستور الشرعي

فالأخذ بالتكافل الاجتماعي في الإسلام هو من قبيل تطبيق النص، وهو ما عبّر عنه القرآن الكريم بقوله تعالى: ﴿إِنَّمَا الْمُؤْمِنُونَ إِخْوَةٌ فَأَصْلِحُوا بَيْنَ أَخَوَيْكُمْ وَاتَّقُوا اللَّهَ لَعَلَّكُمْ تُرْحَمُونَ﴾ [الحجرات: 10]. وقوله تعالى: ﴿وَتَعَاوَنُوا عَلَى الْبِرِّ وَالتَّقْوَىٰ حَتَّىٰ لَا تَعَاوَنُوا عَلَى الْإِثْمِ وَالْعُدْوَانِ﴾. [المائدة: 2].

هذا بالنسبة للدلائل الشرعية من الكتاب، أما بالنسبة للسنة النبوية فيقول صلى الله عليه وسلم: «إنّ المؤمن للمؤمن كالبنيان يشدّ بعضه بعضاً - وشبك أصابعه -». [البخاري: 2585]. وقوله صلى الله عليه وسلم: «لا يؤمن أحدكم حتى يحب لأخيه ما يحب لنفسه». [البخاري: 45].

رابعاً: الاهتمام بالعاجزين وتهيئة العمل للقادرين

إنّ التكافل الاجتماعي يوجب سدّ حاجة المحتاجين ممّن لا يستطيعون القيام بعمل يسدّ عجز العاجزين، ويهيئ العمل للقادرين، ويسهل الحياة للذين لا يملكون القدرة على العمل وفاء لما قدموا من خدمات للمجتمع. [محمد أبو زهرة: 5].

وإنّ التكافل الاجتماعي لا يقصد به إيجاد الحد الأدنى للمعيشة بالنسبة إلى الفقراء والعاجزين، بل يعمل التكافل الاجتماعي على تحقيق مستوى أعلى من ذلك هو حد الكفاية، كما يعمل على توفير وسائل العمل للقادر عليه، حتى ينتقل من فقير سائل عالة على غيره إلى عامل منتج يشارك في نهضة المجتمع وتنميته.

خامساً: تقوية أواصر التعاون ونبذ التفرقة والشتمات

إنّ من أبرز ما يحققه التكافل الاجتماعي هو أن تقوم العلاقات الاقتصادية بين الناس على دعائم من التكافل والتراحم والتعاطف والتواصي بالصدق والعدل والإحسان، وأن يجانبوا في معاملاتهم بعضهم مع بعض كل ما يبأه الخلق السليم، وما يؤدي إلى التنافر والتباغض وصراع الطبقات بعضها مع بعض واضطراب حياة الجماعات. [وافي علي: 65].

وفي جو كهذا لا تجد فئة ظالمة، وأخرى مظلومة، ولا تجد فئة مستغلة، وأخرى مستغلة، وفي هذا الجو لا يمكن أن يقع التنابذ بين الناس، ومن خلاف يتمنى فريق زوال نعمة الفريق الآخر، بل إن أواصر الصداقة والمحبة والأخوة تسود بين الناس. [الرفاعي: 70]. وهذا ما يسعى إلى تطبيقه كل داعية افتداء بالداعية الأول الرسول صلى الله عليه وسلم.

سادساً: الحفاظ على جوهر الكرامة الإنسانية

من أهمّ مبادئ هذا الدين أن المجتمع مصونة كرامته، وصاحب الطاعة فيه مضمون له الثواب، ليس هناك أحد تنكسر نفسه من أحد، وليس هناك أحد تخدش عزّته حتى لحماية غير المكلفين. [الشعر اوي: 75].

ومن ثمّ فإنّ عناية الإسلام بالمجتمع نابعة من تقريره لكرامته الإنسانية؛ لأنه هو الأساس في صنع حضارة العالم وازدهار الحضارة والتقدم والرفاهية؛ لذلك حث الإسلام اتباعه على أن يتعاونوا على البر والتقوى، قال تعالى: ﴿وَتَعَاوَنُوا عَلَى الْبِرِّ وَالتَّقْوَىٰ حَتَّىٰ لَا تَعَاوَنُوا عَلَى الْإِثْمِ وَالْعُدْوَانِ﴾

[المائدة:2]. وأن يتواصوا بينهم بالحق والصبر، قال تعالى: ﴿وَتَوَاصَوْا بِالْحَقِّ وَتَوَاصَوْا بِالصَّبْرِ﴾ [العصر:3]. وأن يكونوا جميعاً كالجسد الواحد قلبهم كمثل اليدين تغسل أحدهما الأخرى، ويتمثل ذلك الترابط فيما بين أفراد المجتمع في قوله صلى الله عليه وسلم: «ترى المؤمنين في تراحمهم وتوادهم وتعاطفهم كمثل الجسد إذا اشتكى عضواً تداعى له سائر جسده بالسهر والحمى». [البخاري:6011].

وأن يقول كل إنسان: «لن أكون إلا إذا كان أخي، ولن يكون أخي إلا إذا كنت»، ما أجمل الإحسان، وما أجمل التعاون، فلنجعل المال في أيدينا والحب في قلوبنا، ونعمل على أسعاد أنفسنا بالمال لنشعر بالأمن والاستقرار وبهذا يفرح المؤمنون وتنتصر الفضائل الأخلاقية. [الرفاعي:83].

فالإسلام إذن يعطي التكافل الاجتماعي، ويقيم مجتمعه على التكافل مع المحافظة الكاملة على إنسانية الإنسان وكرامته وعرضه؛ لأن الشعور بهذه الإنسانية وهذه الكرامة لمن أسمي ما يصيبوا إليه هذا الدين، قال تعالى: ﴿يَقُولُونَ لِنَنْ رَجَعْنَا إِلَى الْمَدِينَةِ لِيُخْرِجَنَا الْأَعْرَابُ مِنْهَا الْأَذَلَّ وَلِلَّهِ الْعِزَّةُ وَلِرَسُولِهِ وَلِلْمُؤْمِنِينَ وَلَكِنَّ الْمُنَافِقِينَ لَا يَعْلَمُونَ﴾ [المنافقون:8].

المطلب الرابع: دور التكافل الاجتماعي في زمن كورونا

إن سنة الله تعالى في خلقه أن يتفاوت الناس في المنح والعطايا والأموال والأولاد وغير ذلك، ولم يكن ذلك تفضيلاً من الله تعالى لغني على فقير أو العكس، وإنما لتحقيق مراد الله وضمان استمرار الحياة؛ وذلك من خلال أمرين:

الأول: تحقيق التكامل الاجتماعي، حيث جعل الله تعالى هذا التفاوت سبباً في نفع الناس بعضهم بعضاً، قال تعالى: ﴿أَهُمْ يَقْسِمُونَ رَحْمَتَ رَبِّكَ نَحْنُ قَسَمْنَا بَيْنَهُمْ مَعِيشَتَهُمْ فِي الْحَيَاةِ الدُّنْيَا وَرَفَعْنَا بَعْضَهُمْ فَوْقَ بَعْضٍ دَرَجَاتٍ لِيَتَّخِذَ بَعْضُهُمْ لِبَعْضٍ سُلْحَاباً وَرَحِمَتْ رَبِّكَ خَيْرٌ مِمَّا يَجْمَعُونَ﴾ [الزخرف:32].

الثاني: اختبار الناس وتمحيصهم: فقد جعل الله هذا التفاوت اختباراً للغني والفقير، فالغني يمتحن في ماله من أين جمعه وفيما أنفقه؟، والفقير يمتحن في فقره كيف كان صبره في حاجته؟ قال تعالى: ﴿وَنَبِّئْكُمْ بِالشَّرِّ وَالْخَيْرِ فِتْنَةً﴾ [الأنبياء:35]. [اليوم السابع: 2/ 4/ 2020].

وهناك العديد والكثير من المبادرات الفردية والجماعية التابعة للجهات المعنية والحكومية والقطاع الخاص والجمعيات الخيرية، والأهالي في بعض المناطق والأحياء، لمساعدة المحتاجين، ولتوفير الاحتياجات الأساسية من مواد تموينية أو غيرها، وتوزيعها على الأسر الفقيرة والمحتاجة، وعلى عمال اليومية الذين تقطعت بهم السبل جراء توقف العمل في المنشآت العاملة فيها.

وفي هذه الأيام العصبية التي نمر بها، نتيجة فيروس كورونا المستجد، الذي عم العالم بأكمله، وعكس آثاره السلبية وضرره الكبير على مجمل الحياة الاجتماعية والاقتصادية والعملية والثقافية، فكم نحن بحاجة للتعاقد والتكافل الاجتماعي. وكان أكبر الضحايا في ذلك هم صغار العاملين وعمال اليومية، الأمر الذي عزز بشكل كبير أهمية التكافل الاجتماعي، لا سيما في دول العالم الثالث والعالم الإسلامي.

إن التكافل الاجتماعي هو الحل الإسلامي لسد حاجة الفقراء وعدم وجود جائع أو محتاج لا يستطيع العيش في ظل وجود قادرين على مساعدتهم. وأن أجواء كورونا فتحت أبواباً واسعة إلى الجنة أمام القادرين والميسورين، بفضل أوجه الخير الكثيرة المطلوبة والمتاحة في هذا الوقت، سواء من حيث التبرع وتقديم المساعدة من أجل علاج المرضى، أو التبرع لدعم العمالة المؤقتة التي فقدت مصدر دخلها بسبب أجواء الحظر وإغلاق الأنشطة الاقتصادية.

وإن التكافل الاجتماعي في الإسلام ليس معنياً بالمسلمين فقط، بل يشمل الأفراد الذين يعيشون داخل الوطن، لا سيما وأن أساس التكافل هو كرامة الإنسان، مؤكداً أن المجتمع الإسلامي لا يعرف الفردية أو الأنانية أو السلبية، وإنما يعرف عنه الإخاء الصادق، والعطاء والتعاون على البر والتقوى دائماً. [السبيل: 7/ 4/ 2020].

ولا بدّ قيام المتكفل بعملية بحث عميقة حتى يصل إلى الأشخاص الذين يستحقون تطبيق التكافل الاجتماعي عليهم، لافتاً إلى الفئة الأولى بتفصيل التكافل عليها وفقاً للقرآن الكريم، الذي قال الله عنهم: ﴿لِلْفُقَرَاءِ الَّذِينَ أُحْصِرُوا فِي سَبِيلِ اللَّهِ لَا يَسْتَطِيعُونَ ضَرْباً فِي الْأَرْضِ يَحْسَبُهُمُ الْجَاهِلُ أَغْيَاءً مِنَ التَّعَفُّفِ تَعْرِفُهُمْ بِسِيمَاهُمْ لَا يَسْأَلُونَ النَّاسَ إِحْصَاءً وَمَا تَنْقُضُوا مِنْ خَيْرٍ فَإِنَّ اللَّهَ بِهِ عَلِيمٌ﴾ [البقرة:237].

إنّ تقديم العون والمساعدة للفئات الاجتماعية الأكثر هشاشة في مثل هذه الظروف؛ كونها الأكثر عرضة لهذه العدوى، وبشكل خاص الأشخاص المرضى بالأمراض المزمنة، وكبار السن، وذوي الإعاقة، وذوي الدخل المحدود والمُعوزين من الفقراء والمساكين وغيرهم، تحسباً لكل الآثار والانعكاسات الوخيمة التي قد تترتب عن نقشي الوباء.

ومن أهمية نتائج آثار التضامن الاجتماعي شعور الفرد بأنه غير منفصل عن المجتمع وغير معزول عن الناس لوقوفهم إلى جانبه في السواء والضراء، وتوثيق الصلات والعلاقات الأخوية، وتعزيز الروابط المجتمعية بين الناس وتقوية أواصر المحبة بينهم، وقوة تماسك المجتمع وتلاحمه وترابطه في مواجهة الأزمات والكوارث.

إنّ المساهمة في توعية أفراد المجتمع وتأييدهم لمواجهة هذه الظروف والتبرع بالمال في مساندة الجهود الوطنية المبذولة لمواجهة الأزمة التي تمر بها العالم، انطلاقاً من المسؤولية المجتمعية تجاه الدولة والمؤسسات التي تبذل جهوداً كبيرة لاحتواء انتشار فيروس «كورونا». [الدستور: 1144086].

وتبين الاختصاصية الاجتماعية: في الأزمات والظروف الصعبة تتجدد روح التعاون، والتعاضد، والمسؤولية الجماعية، والتكافل الاجتماعي مما يساهم في تعزيز العلاقات الاجتماعية وعمق الصلات الأسرية والأخوية، ومن الممارسات والعادات الاجتماعية الإيجابية في جائحة الكورونا يزداد الشعور بالآخرين، وتقديم يد العون لهم وخصوصاً الجيران والأهالي والمحتاجين والفقراء. [صحيفة الرأي: 10530239].

ومن أهم أنواع التكافل في الفترة الحالية، التكافل الصحي من خلال الابتعاد عن مخالطة الناس وعدم نقل العدوى للآخرين، لا سيما وأن هذا الأمر مقدم الآن على أي تكافل آخر بالرغم من حاجتنا الماسة للتكافل الاجتماعي، والمادي والمعنوي.

وفيما يخص التكافل المعنوي، وهو يأتي عن طريق عدم الاستهزاء بالمصابين بالمرض والانتعاش منهم، أما التكافل المادي فيأتي من خلال تقديم المساعدات العينية وهي واجبة علينا جميعاً ولا يجوز التقاعس في تقديمها من قبل المقترنين. [السبيل: 7/ 4/ 2020].

وأخيراً نقل الباحث قولاً عن أحد الجيران الذي يعبر مشاعره: «لم أكن أتواصل مع الجيران إلا في المصعد ولكن استغربت عندما طرق الباب يوماً، وإذا بجارتي تسألني هل أنت بخير، تحتاجون شيئاً، وقتها شعرت بالأمان، بأنّ هناك خيراً ما زال موجوداً في ظل الظروف الصعبة التي

يمرّ بها الوطن لواجهة فيروس كورونا، وأنّ أحدا من الجيران يطمئن، وأصبحنا مع مرعاة السلامة العامة والصحية نعمل على تقديم العون والمساعدة للجيران وخصوصاً المحتاجين والفقراء». [صحيفة الرأي: 10530239].

خاتمة البحث:

بعد هذه الجولة العلمية ذكر الباحث في الخاتمة أهمّ النتائج والتوصيات التي توصل إليها من خلال هذه الدراسة الوجيزة:

أولاً: إنّ أساس التكافل الإسلامي هو الحرص على صيانة كرامة الإنسان، ووضع الإسلام الأسس النفسية والوسائل المادية والمعنوية على أساس الأخوة، لقوله تعالى: ﴿إِنَّمَا الْمُؤْمِنُونَ إِخْوَةٌ فَأَصْلِحُوا بَيْنَ أَخَوَيْكُمْ وَاتَّقُوا اللَّهَ لَعَلَّكُمْ تُرْحَمُونَ﴾ [الحجرات: 10].

ثانياً: إنّ التكافل الاجتماعي لا يقتصر على النفع المادي فقط، بل يتجاوزها إلى حاجات المجتمع المعنوية، لذلك يتضمن جميع الحقوق الأساسية للأفراد والجماعات داخل المجتمع على اختلاف دياناتهم ومعتقداتهم.

ثالثاً: إنّ التضامن بين أفراد المجتمع مظهر من مظاهر التعاون التي تحد من تداعيات فيروس كورونا، وفيه تحقيق للأهداف والغايات التي بنتت طلبها متطلبات دعم صمود الإنسان وتلبية الاحتياجات المجتمعية في ظل انعدام الموارد، وهذا التضامن يقود إلى تعزيز أهمية التعاون بين أفراد المجتمع.

رابعاً: رتب على الإيمان حقوقاً للآخرين، فلا يؤمن الفرد ما لم يحب لأخيه ما يحب لنفسه، ويعيش معه كالبنين يشد بعضه بعضاً، وجعل العدل وحفظ الحقوق من قيم الدين الأساسية. بل ندب إلى عدم الاقتصار على العدل، وإنما إلى الارتقاء إلى الاحسان والايتار من أجل إشاعة جو العفو والرحمة والمودة بين الناس.

خامساً: طبق رسول الله صلى الله عليه وسلم مبدأ التكافل الاجتماعي على أرض الواقع في أبهى صورة، وأشرف مقصد حين آخى بين المسلمين مرة، وآخى بين المهاجرين والأنصار مرة أخرى ليجسد لنا روح الإسلام في أروع المعاني، وأدل الصور حين لم يكن للدولة خزينة أو بيت مال ينفق منه على من يستحق النفقة، فكان المسلمون كالبنين المرصوص يشد بعضهم بعضاً.

ومن أهمّ التوصيات: ضرورة شيوع روح المساعدة بين الناس في هذا الطرف الاستثنائي، وهذه المرحلة الصعبة التي يمر بها العالم، وأن لا نفكر فقط بانفسنا، بل علينا ان نتعاون ونفكر بمن هم حولنا من أخ وجار وقريب وصديق، لتجاوز هذه الضائقة الصعبة، والأوقات الراهنة.

المصادر والمراجع

- القرآن الكريم
 آل محمود: عبد اللطيف محمود. (1994م). التأمين الاجتماعي في ضوء الشريعة الإسلامية. (د.ط). دار النفائس. بيروت - لبنان.
 أبو داود: سليمان ابن الأشعث. (2005م). سنن أبي داود. ضبطه محمد عبد العزيز. (د.ط). دار الكتب العلمية. بيروت - لبنان.
 أحمد عبده سعيد البني. (د.ت). الضمان الاجتماعي في الإسلام. (د.ط). دار الفكر العربي. القاهرة.
 البخاري: أبو عبد الله محمد بن إسماعيل البخاري. (د.ت). صحيح البخاري. (د.ط). دار صادر. بيروت - لبنان.
 التركي: عبد الله بن عبد المحسن. (1419هـ). حقوق الإنسان في الإسلام. طباعة وزارة الشؤون الإسلامية. الرياض - المملكة العربية السعودية.
 رحيم علي صباح. (2013م). فلسفة التكافل الاجتماعي عند الإمام علي رضي الله عنه. مجلة كآية التربية الأساسية. جامعة بابل - العراق. العدد: 14. كانون أول 2013م.
 الزهرى: محمد بن سعد. (د.ت). الطبقات الكبرى. تحقيق: محمد علي عمي. (د.ط). مكتبة الخانجي. القاهرة - مصر.
 السيد أحمد المخزنجي. (د.ت). مقومات المجتمع في عهد الرسول صلى الله عليه وسلم. مجلة الوعي الإسلامي. العدد 207.
 سيد قطب. (د.ت). العدالة الاجتماعية في الإسلام. (د.ط). دار الشروق. القاهرة - مصر.
 الطبراني: أبو القاسم سليمان بن أحمد الطبراني. (1415هـ). المعجم الأوسط. تحقيق: طارق بن عوض الله بن محمد وعبد المحسن بن إبراهيم الحسيني. (د.ط). دار الحرمين. القاهرة - مصر.
 عبد اللطيف الشكري. (د.ت). الضمان الاجتماعي في الإسلام. مجلة الوعي الإسلامي. العدد 276.
 عبد الله ناصح علوان. (1409هـ). التكافل الاجتماعي في الإسلام. (د.ط). دار السلام. القاهرة.
 عبيد منصور الرفاعي. (د.ت). الإسلام والتكافل الاجتماعي. (د.ط). دار الفكر العربي. القاهرة.
 قضايا الفكر الإسلامي المعاصر. (1978م). منظمة الندوة العالمية للشباب الإسلامي. أبحاث ووقائع اللقاء الثاني للندوة العالمية للشباب الإسلامي المنعقد في الرياض في الفترة بين 17-27 من ديسمبر 1973م.
 محمد أبو زهرة. (1405هـ). التكافل الاجتماعي في الإسلام. وزارة التربية والتعليم. جمهورية مصر العربية.
 محمد أبو زهرة. (د.ت). التكافل الاجتماعي في الإسلام. (د.ط). دار الفكر العربي - القاهرة.
 محمد فرج سليم. (د.ت). التكافل الاجتماعي في الإسلام. (د.ط). دار العلم. بيروت - لبنان.
 محمد متولي الشعراوي. (1986م). كيف نفهم الإسلام. دار العودة. بيروت - لبنان.
 محمود محمد الخزندر. (1997م). من أخلاقيتنا حين نكون مؤمنين حقاً. الطبعة الثانية. دار طيبة. الرياض.
 محمود شلتوت. (د.ت). الإسلام عقيدة وشريعة. (د.ط). دار القلم. بيروت - لبنان.
 النيسابوري: مسلم بن الحجاج النيسابوري. (د.ت). صحيح مسلم. (د.ط). دار صادر. بيروت.
 وافي علي عبد الواحد. (1966م). حقوق الإنسان في الإسلام. الطبعة السادسة. دار النهضة. القاهرة.

المواقع الإلكترونية

01. <https://www.addustour.com/articles/1144086>
02. <https://www.youm7.com/story/2020/4/2>
03. <https://assabeel.net/news/2020/4/7>
04. <https://qudsnet.com/post/484038>
05. <http://alrai.com/article/10530239>

THE BASIC RULES FOR FINANCIAL TRANSACTIONS AND THEIR IMPACT ON ISLAMIC BANKING

Mohamed Hamadikinane Maiga

الضوابط الأساسية للمعاملات المالية وأثرها في الصيرفة الإسلامية د. محمد حمد كنان ميغا* كلية الشريعة والقانون، جامعة السلطان الشريف علي الإسلامية في بروناي

الملخص

المعاملات المالية الإسلامية أساسها التيسير على الناس في نقل الملكيات والمنافع وطرق الكسب من خلال المعاوزات، ولحفظ حقوق الناس المالية وضع الإسلام ضوابط للمعاملات المالية تراعى مصلحة أطراف المعاملة. وإشكالية هذا البحث نابعة من التساهل والتسيب الظاهر في المعاملات المالية، وبخاصة فيما يتعلق بالمؤسسات المالية التجارية (المصارف الإسلامية) من حيث الاعتماد على الحيل، وما يكتنف بعض معاملاتها من الغموض. ويهدف هذا البحث إلى الكشف عن الضوابط الأساسية للمعاملات المالية في الفقه الإسلامي، وآليات تطبيقها في المعاملات المصرفية الإسلامية، وبيان أثرها على الصيرفة الإسلامية؛ من حيث تطوير أدائها مع المرونة، والابتعاد عن الشبهات والحيل الموصلة إلى الربا. والمنهج المتبع في هذا البحث هو المنهج الوصفي التحليلي المبني على جمع البيانات من مصادر مختلفة، وتصنيفها ثم تحليلها من أجل تحقيق أهداف البحث. وخلص البحث إلى أن الأصل في المعاملات الإباحة، وأن العبرة في المعاملات بالظاهر، وأن المعاملات مبنية على المرونة والرفق والسماحة، وكذلك الابتعاد عن الحيل وشبهة الربا.

الكلمات المفتاحية: الضوابط الأساسية، المعاملات المالية، الصيرفة الإسلامية

Abstract

Islamic financial transactions are based on facilitation for people to transfer property, benefits, and methods of earning through offsets. In order to preserve people's financial rights, Islam established financial rules that take into account the interests of the parties to the transaction. The problem statement of this research stems from the leniency and apparent abuse of financial transactions. This research aims to revealing the basic rules for financial transactions in Islamic jurisprudence, the mechanisms of their application in Islamic banking transactions, highlighting their impact on Islamic banking, in terms of developing their performance with flexibility, and also stay away from suspicions and tricks connected to usury. The methodology used in this research is analytically based on the classification and analysis of data, in order to achieve the research objectives. The research concluded that, the permission is a basis of transactions, in the transactions consideration on the appearance, transactions are based on flexibility, kindness, tolerance, and also away from tricks and suspicion of usury.

• **Key words:** Basic rules, Financial transactions, Islamic banking

•

•

1. مقدمة

الإنسان بحاجة إلى التعامل مع غيره من الناس من أجل تبادل الأعيان أو المنافع، ولذلك شرع الإسلام المعاملات المالية ووضع لها ضوابط لحفظ حقوق الناس المالية مع مراعاة مصلحة أطراف المعاملة. وجعل التيسير والرفق والسماحة من أساسيات المعاملات المالية.

1.1 إشكالية البحث:

إشكالية هذا البحث تكمن في اعتماد المؤسسات المالية التجارية على الحيل، وكذلك عدم الوضوح في كثير من تعاملها، وعدم التحرز من الشبهات. ويسعى البحث لحل هذه الإشكالية من خلال الأهداف التالية:

- بيان ما يكتنف أعمال المصارف الإسلامية من الشبهات والحيل.
- الكشف عن الضوابط الأساسية للمعاملات المالية الإسلامية.
- بيان أثر هذه الضوابط في الصيرفة الإسلامية.

2.1 منهج البحث:

المنهج المتبع في هذا البحث هو المنهج الوصفي التحليلي المبني على جمع البيانات وتصنيفها ثم تحليلها قصد تحقيق أهداف البحث، وهذا يتم بالرجوع إلى الكتب المتخصصة في الموضوع، وإلى المجلات المتخصصة، والمقالات المنشورة في المعاملات المالية الإسلامية عبر المواقع الإلكترونية، لدراسة مضمونها والخروج بما يساعد في تحرير هذا البحث على وجه يحقق أهداف هذا البحث.

3.1 الدراسات السابقة:

حسين شحاتة، الضوابط الشرعية لإدارة أموال اليتامى، هذه دراسة مختصرة في حدود خمس صفحات نُشرت في موقع دار المشورة للاقتصاد الإسلامي، تحدث فيها الباحث عما يجب الالتزام به في إدارة أموال اليتامى من الضوابط الشرعية. فهي تلتنق مع بحثنا في بعض الضوابط، ولكنها تختلف عن بحثنا في المنهج والمضمون.

منذ قحف، السياسات المالية دورها وضوابطها في الاقتصاد الإسلامي، هذه الدراسة تناولت مالية الدولة من حيث الإيرادات وضوابط التحكم فيها، والنفقات والضوابط الشرعية للتحكم فيها، وعجز الموازنة والضوابط الشرعية المتعلقة به، وأخيرًا سياسات الذخول والأسعار وضوابطها الشرعية. فهذه الدراسة تلتقي مع بحثنا في بعض الضوابط، ولكنها تختلف عن بحثنا منهجًا ومضمونًا، وحتى في كيفية إيراد الضوابط.

الزهراء علي عباس محمد، الحافظ على المال في التشريع الإسلامي، هذه الدراسة نُشرت في موقع الألوكة، وهي تلتقي مع بحثنا فيما ورد فيها عن الحافظ على الأموال بتحريم الربا، والرشوة، وعدم تسليم المال لمن لا يحسن التصرف فيه. ولكنها تختلف عن بحثنا منهجًا ومضمونًا، لأنها لم تتحدث عن هذه العناصر كضوابط للمعاملات المالية.

مبارك بن سليمان، أحكام التعامل في الأسواق المالية المعاصرة، هذه الدراسة كتاب منشور أصله رسالة دكتوراة من جامعة الإمام محمد بن سعود الإسلامية. تلتقي مع بحثنا في بعض الموضوعات وهي: نقل الملكية، المعاملات العاجلة وأحكامها الفقهية، العقود المستقبلية وأحكامها الفقهية، غود الاختيار وأحكامها الفقهية، عقود المبادلات وأحكامها الفقهية. ولكنها تختلف عن بحثنا في عدم تحديدها لضوابط المعاملات المالية الإسلامية التي هي أساس بحثنا هذا.

زيد بن محمد الرماني، مقاصد الشريعة في الكسب، هذه الدراسة كتاب نشرته موقع الألوكة، وتلتقي مع بحثنا هذا في أغلب ما ورد فيها تحت ضوابط الكسب، ولكنها تختلف عن بحثنا في المنهج والمضمون.

2. الشبهات في المعاملات المالية المصرفية الإسلامية

1.2. الاعتماد على الحيل وعدم الاحترز من شبهة الربا

الحيل نوعان: نوع جائز وهو ما يحق الحق ويطلب الباطل. ونوع منبني على الظلم وإسقاط الواجبات وتحليل المحرمات. (قال ابن القيم د.ت): فالأول: نوع يتوصل به إلى فعل ما أمر الله تعالى به، وترك ما نهى عنه والتخلص من الحرام، وتخليص الحق من الظلم المانع له، وتخليص المظلوم من يد الظالم الباغي، فهذا النوع محمود يثاب فاعله ومعلمه. والثاني: نوع يتضمن إسقاط الواجبات، وتحليل المحرمات، وقلب المظلوم ظالمًا، والظالم مظلومًا، والحق باطلاً والباطل حقًا، فهذا النوع الذي اتفق السلف على ذمّه، وصاحوا بأهله من أقطار الأرض.ⁱ

(ابن تيمية 1987) المتحايلون على أكل الربا إما أن يضمنوا إلى أحد العوضين ما ليس بمقصود، أو يضمنوا إلى العفد عقداً ليس بمقصود،ⁱⁱ وكلاهما ممنوع عند جمهور العلماء لمنافستهما للأصول الشرعية في المعاملات المالية.

(ابن القيم 1991) والحيلة تكون بطرق متعددة، منها حمل اللفظ فوق ما يحتمله، كما حمل لفظ قول الله تعالى: ﴿يَأْيُهَا الَّذِينَ ءَامَنُوا لَا تَأْكُلُوا أَمْوَالَكُمْ بَيْنَكُمْ بِالْبُطْلِ إِلَّا أَنْ تَكُونَ تِجَارَةً عَنْ تَرَاضٍ مِّنْكُمْ﴾، (النساء: 29). وقوله تعالى: ﴿إِلَّا أَنْ تَكُونَ تِجَارَةً حَاضِرَةً تُدِيرُهَا وَيَتَدَارَعُ فِيهَا﴾، (البقرة: 282)، مسألة العينة التي هي ربا بجيلة وجعلها من التجارة، ولعمرك الله إن الربا الصريح تجارة للمرابي وأي تجارة.ⁱⁱⁱ (قال ابن القيم 1991): " وَأَخْرَجَتْ طَافَةَ أُخْرَى مِنْهُ مَا هُوَ مِنَ الرِّبَا الصَّحِيحِ حَقِيقَةً قَصْدًا وَشَرَّ عَا كَالْحَيْلِ الرَّبَوِيَّةِ الَّتِي هِيَ أَعْظَمُ مَفْسَدَةً مِنَ الرِّبَا الصَّرِيحِ، وَمَفْسَدَةُ الرِّبَا الْبَحْتِ الَّتِي لَا يَتَوَصَّلُ إِلَيْهِ بِالسَّلَامِ أَقْلٌ بِكَثِيرٍ، وَأَخْرَجَتْ مِنْهُ طَائِفَةٌ بَيْعِ الرُّطْبِ بِالتَّمْرِ وَإِنْ كَانَ كَوْنُهُ مِنَ الرِّبَا أَخْفَى مِنْ كَوْنِ الْحَيْلِ الرَّبَوِيَّةِ مِنْهُ، فَإِنَّ التَّمَالَ مَوْجُودٌ فِيهِ فِي الْحَالِ دُونَ الْمَالِ، وَحَقِيقَةُ الرِّبَا فِي الْحَيْلِ الرَّبَوِيَّةِ أَكْمَلُ وَأَتَمُّ مِنْهَا فِي الْعُقْدِ الرَّبَوِيِّ الَّتِي لَا حَيْلَةَ فِيهِ."^{iv}

ومنها تغيير صفة الشيء وصورته وتسميته بغير اسمه، كما فعل اليهود لما حرم الله عليهم الشحوم وأذواها ثم باعواها وأكلوا ثمنها، كما ورد في الصحيحين (البخاري 2001، مسلم د.ت) بألفاظ مختلفة منها: «قَاتَلَ اللَّهُ الْيَهُودَ، حَرَّمَ اللَّهُ عَلَيْهِمُ الشُّحُومَ، فَبَاعُواهَا وَآكَلُوا ثَمَنَهَا»،^v وهي حيلة محرمة. (ابن القيم 1991) قَالَ الْخَطَّابِيُّ: "فِي هَذَا الْحَدِيثِ بُطْلَانُ كُلِّ حَيْلَةٍ يَحْتَلُّ بِهَا الْمُتَوَسِّلُ إِلَى الْمَحْرَمِ؛ فَإِنَّهُ لَا يَتَغَيَّرُ حُكْمُهُ بِتَغْيِيرِ هَيْئَتِهِ وَتَبْدِيلِ اسْمِهِ". قال ابن القيم: قَالَ شَيْخُنَا - رَضِيَ اللَّهُ عَنْهُ -: وَوَجْهُ الدَّلَالَةِ مَا أَشَارَ إِلَيْهِ أَحْمَدُ أَنَّ الْيَهُودَ لَمَّا حَرَّمَ اللَّهُ عَلَيْهِمُ الشُّحُومَ أَنْ يَبِيعُوا الْإِخْتِيَالَ عَلَى الْإِنْتِفَاعِ بِهَا عَلَى وَجْهِ لَا يُقَالُ فِي الظَّاهِرِ إِنَّهُمْ انْتَفَعُوا بِالشُّحْمِ فَحَمَلُوهُ وَقَصَدُوا بِذَلِكَ أَنْ يَرُودَ عَنْهُ اسْمُ الشُّحْمِ، ثُمَّ انْتَفَعُوا بِثَمَنِهِ بَعْدَ ذَلِكَ لِئَلَّا يَكُونَ الْإِنْتِفَاعُ فِي الظَّاهِرِ بِعَيْنِ الْمَحْرَمِ، ثُمَّ مَعَ كَوْنِهِمْ اخْتَلَوْا بِحَيْلَةٍ حَرَجُوا بِهَا فِي زَعْمِهِمْ مِنْ ظَاهِرِ التَّحْرِيمِ مِنْ هَذَيْنِ الْوَجْهَيْنِ لَعَنَهُمُ اللَّهُ عَلَى لِسَانِ رَسُولِ اللَّهِ - صَلَّى اللَّهُ عَلَيْهِ وَسَلَّمَ - عَلَى هَذَا الْإِسْتِحْلَالِ، نَظَرًا إِلَى الْمُقْصُودِ، وَأَنَّ حِكْمَةَ التَّحْرِيمِ لَا تَحْتَلِفُ سِوَاءَ كَانَ جَامِدًا أَوْ مَائِعًا، وَبَدَلَ الشَّيْءِ يَقُومُ مَقَامَهُ وَيَسُدُّ مَسَدَّهُ، فَإِذَا حَرَّمَ اللَّهُ الْإِنْتِفَاعَ بِشَيْءٍ حَرَّمَ الْإِعْتِيَاظَ عَنْ تِلْكَ الْمُنْفَعَةِ."^{vi}

وهذا الحكم يجري على الحيل الربوية كلها؛ لأن الربا إنما حرمت لحقيقتها وما يترتب عليها من المفساد لا لصورها الظاهرة. (قال ابن القيم 1991): "وَهَكَذَا الْحَيْلُ الرَّبَوِيَّةُ؛ فَإِنَّ الرِّبَا لَمْ يَكُنْ حَرَامًا لِصُورَتِهِ وَلَفْظِهِ، وَإِنَّمَا كَانَ حَرَامًا لِحَقِيقَتِهِ الَّتِي ائْتَمَرَ بِهَا عَنْ حَقِيقَةِ الْبَيْعِ؛ فَتِلْكَ الْحَقِيقَةُ حَيْثُ وُجِدَتْ وَجَدَ التَّحْرِيمُ فِي أَيِّ صُورَةٍ رُكِبَتْ وَبِأَيِّ لَفْظٍ عَرِبَ عَنْهَا؛ فَلَيْسَ الشَّأْنُ فِي الْأَسْمَاءِ وَصُورِ الْعُقُودِ، وَإِنَّمَا الشَّأْنُ فِي حَقَائِقِهَا وَمَقَاصِدِهَا وَمَا عُقِدَتْ لَهُ."^{vii} (ابن القيم 1991) فالحيلة لا ترفع المفسدة التي حرم الربا من أجلها بل يزيد قوة وتأكيدها، وذلك لعدة أسباب: منها: أن المتحايل على أكل الربا واثق بصورة العقد واسمه وثوقاً يحول دون الرجوع عنه. ومنها: أنه يعتقد جل تلك الزيادة وطبيعتها بخلاف المرابي صريحاً وذلك مانع له من تركها واعتبارها حراماً. ومنها: أنه يعتقد أنها تجارة حاضرة مدارة كسائر التجارات المباحة شرعاً.^{viii}

فالحيل المحرمة تناقض قاعدة سد النزاع، وتناقض الأصول الشرعية في التحرز من الحرام، وتناقض كذلك أصول أئمة المذاهب الفقهية، ومضادة للنصيحة للمسلم، والسلمة في البيع. (قال ابن تيمية 1987): "فَإِذَا كَانَتْ النَّصِيحَةُ لِكُلِّ مُسْلِمٍ وَاجِبَةً وَغَشَهُ حَرَامًا، فَمَعْلُومٌ أَنَّ الْمُخْتَالَ لَيْسَ بِنَاصِحٍ لِلْمُخْتَالَ عَلَيْهِ بَلْ هُوَ غَاشٌّ لَهُ، بَلْ الْحَيْلَةُ أَكْبَرُ مِنْ تَرْكِ النَّصْحِ وَأَقْبَحُ مِنَ الْغَشِّ، وَهَذَا بَيِّنٌ يَظْهَرُ مِثْلُهُ فِي الْحَيْلِ الَّتِي تُبْطِلُ الْحُقُوقَ الَّتِي تَبَيَّنَتْ. أَوْ تَمْنَعُ الْحُقُوقَ أَنْ تَبَيَّنَتْ. أَوْ تُوجِبُ عَلَيْهِ شَيْئًا لَمْ يَكُنْ لِيَجِبْ."^{ix} وكذلك الحيل المحرمة مخدعة لله، ومخدعة الله حرام بالإجماع. (ابن القيم 1993) ومن

المخدعة "دخول المخل في عقد العينة ونحوها من العقود المشتبهة على الحيل الربوية".^x وذلك أن العينة ثلاثة أقسام: "أخذها: ما يكون من واحد، كما إذا باعه سلعةً بئسبئته، ثم اشتراها منه بأقل من ثمنها نقداً، حيلة على الربا. ومنها: ما تكون بئسبئته، وهي أن تكون من اثنين: مثل أن يجمع إلى القرض بيعاً أو إجازة أو مساقاة أو مزارعة ونحو ذلك، وقد ثبت عن النبي - صلى الله عليه وسلم - أنه قال: «لَا يَحِلُّ سَلْفٌ وَبَيْعٌ، وَلَا شَرْطَانٌ فِي بَيْعٍ، وَلَا رَيْحٌ مَا لَمْ يَضْمَنْ، وَلَا بَيْعٌ مَا لَيْسَ عِنْدَكَ»، (أبو داود د.ت، الترمذي 1998)^{xi} وفي سنن أبي داود عن النبي - صلى الله عليه وسلم - أنه قال: «مَنْ بَاعَ بَيْعَتَيْنِ فِي بَيْعَةٍ فَلَهُ أَوْكُسُهُمَا أَوْ الرِّبَا». (أبو داود د.ت)^{xii} ومعنى أوكسهما: ألقهما وأنقصهما. (الصنعاني د.ت، الشوكاني 1993، العظيم أبدي 1985)^{xiii}

(1985)^{xiii} وللعلماء تفسيران في بيعتين في بيعة: الأول: كأن يقول هو علي نساء بكذا ويقتد بكذا، وبهذا قال الشافعي وأحمد عن سماك. وهذا التفسير وضعه شارح سنن أبي داود العظيم أبدي؛ لأنه لا يدخل الربا في هذه الصورة ولا صفتين هنا وإنما هي صفة واحدة بأحد الثمنين. والثاني: أن يقول أبيعكها بمائة إلى سنة على أن اشتريها منك بثمانين حاله، وبهذا قال الجمهور منهم: المالكية والشافعية والحنابلة. (الشوكاني 1993، العظيم أبدي 1985)^{xiv} "وهذا معنى الحديث الذي لا معنى له غيره وهو مطبق لقوله فلعله أوكسهما أو الربا فإنه إما أن يأخذ الثمن الرابض في البيوع أو الثمن الأول فيكون هو أوكسهما وهو مطبق لصفتين في صفة". (العظيم أبدي 1985)^{xv} ومنها: ما تكون ثلاثية، وهي أن يدخلها بئسبئته محلاً للربا، فيشتري السلعة من أكل الربا، ثم يبيعه للمعطي الربا إلى أجل، ثم يعيدها إلى صاحبها بنقص ذراهم يستعيدها المخل.^{xvi} (ابن القيم د.ت)

وقد حذر النبي - صَلَّى اللهُ عَلَيْهِ وَسَلَّمَ - أُمَّتَهُ مِنْ أَنْ تَكْتَابَ الْحَيْلَ فَقَالَ: «لَا تَرْتَكِبُوا مَا ارْتَكَبَتْ الْيَهُودُ فَتَسْتَحِلُّوا مَحَارِمَ اللَّهِ بِأَدْنَى الْحَيْلِ». (ابن بطه 1983) xvii "ولا يجوز له ولا غيره تتبع الحيل المحرمة والمكرهه ولا تتبع الرخص لمن أراد نفعه فإن تتبع ذلك فسق وحرم استفتاؤه وإن حسن قصده في حيلة جائزة لا شبهة فيها ولا مفسدة لتخلص المستفتي بها من حرج جزاء، كما أرشد النبي صَلَّى اللهُ عَلَيْهِ وَسَلَّمَ بلا لارضي الله عنه إلى بيع التمر بدراهم ثم يشتري بالدراهم ثمرا آخر فيتخلص من الربا". (الحجاوي دبت) xviii

2.2. تتبّع الرخص والتسهيلات الفقهيّة

يرى الحنفية أنّ تتبّع الرخص فسق، وأنّ الحقّ واحد. (ابن عابدين 1992) xix ويرى المالكية أنّ تتبّع الرخص حرام بالإجماع؛ لأنّه تلاعب بالدّين، ولما تقلد الرخصة يوماً ما للضرورة أو الأخذ بالاحتياط والورع فلا عتب على صاحبه. (زروق 2006) xx ويقصدون بالرخص هنا ما خالف الإجماع، أو القواعد، أو النص، أو القياس الجلي. (الشنقيطي 2015) xxi وعند الشافعية لا يجوز تتبّع الرخص بأن يأخذ من كلّ مذهب بالأسهل منه؛ لأنّ جلال رتبة التكليف من عفة جيّنذ، ومن ثمّ كان الأوجه أنّه يسقّ به. (ابن حجر الهيتمي 1983، عز الدين بن عبد السلام 2016) xxii وعند الحنابلة كذلك لا يجوز تتبّع الرخص، وهل يسقّ أم لا؟ في ذلك تفصيل عندهم. (أبو البركات 1984، ابن مفلح 1984) xxiii (قال المرادوي دبت): "وَلَا يَجُوزُ لِلْعَامِيِّ تَتَبُّعَ الرُّخْصِ. ذَكَرَهُ ابْنُ عَبْدِ الْبَرِّ إِجْمَاعًا. وَيَسْقُ عِنْدَ الْإِمَامِ أَحْمَدَ - رَحِمَهُ اللهُ - وَغَيْرِهِ". xxiv وقال في موضع آخر: "مَنْ تَتَبَعَ الرُّخْصَ فَأَخَذَ بِهَا: فسق، نصّ عليه، وذكره ابن عبد البر - رَحِمَهُ اللهُ - إجماعاً". (المرادوي دبت) xxv

3. الضوابط الأساسية للمعاملات الماليّة

3.1. الضابط الأول: الأصل في المعاملات الماليّة الحلّ

أصل هذا الضابط قول الله تعالى: (وَاحِلٌ اللهُ الَّتِيْعَ وَحَرَّمَ الْزُّبُوْأَ)، (البقرة: 275). وذلك أنّ الإنسان بحاجة إلى ما عند الآخرين من الأشياء فلا يمكن أن يصل إليها إلا عن طريق المعاملات الماليّة المختلفة التي منها المعاوضات والتبرّعات، أو الميراث فهذه هي الحكمة من هذا الضابط ويسري تطبيقه على جميع المعاملات الماليّة، ولا يخرج منها شيء إلا ما ورد فيه نص خاص، فيستثنى منه.

3.2. الضابط الثاني: العبرة في المعاملات الماليّة بالظواهر

أصل هذا الضابط: مجموعة من الأحاديث، منها: حديث أبي هريرة رضي الله عنه في الصحيحين: «أُمِرْتُ أَنْ أَقَاتِلَ النَّاسَ حَتَّى يَشْهَدُوا أَنْ لَا إِلَهَ إِلَّا اللهُ، وَأَنَّ مُحَمَّدًا رَسُوْلُ اللهِ، وَيُقِيمُوا الصَّلَاةَ، وَيُؤْتُوا الزَّكَاةَ، فَيَأْتُوا فَعَلُوا ذَلِكَ عَصَمُوا مِنِّي مَاءَهُمْ وَأَمْوَالُهُمْ إِلَّا بَحَقَّ الْإِسْلَامِ، وَحَسْبُهُمْ عَلَى اللهِ». (البخاري 2001، مسلم دبت) xxvi وحديث أم سلمة رضي الله عنه في الصحيحين، وفيه: «إِنَّمَا أَنَا بَشَرٌ وَإِنَّمَا تَخْتَصِمُونَ إِلَيَّ، وَلَعَلَّ بَعْضَكُمْ أَنْ يَكُونَ أَلْحَنَ بِحُجَّتِهِ مِنْ بَعْضٍ، فَأَقْضِي عَلَى نَحْوِ مَا أَسْمَعُ، فَمَنْ قَضَيْتَ لَهُ مِنْ حَقِّ أَخِيهِ شَيْئًا، فَلَا يَأْخُذْهُ فَإِنَّمَا أَقْطَعُ لَهُ قِطْعَةً مِنَ النَّارِ». (البخاري 2001) xxvii وهذا الضابط من أصول مذهب الشافعية، ويعتبرون عنه باعتماد الظواهر في العقود الشرعيّة، وقد أورد (البيهقي 1991) في "معرفة السنن" أنّ الشافعيّ رَحِمَهُ اللهُ ذكر في كتاب إبطال الاستحسان فصلًا في أنّ الأحكام في الدُّنيا إنّما هي على ما أظهرت العباد، وأنّ الله مُدَبِّرٌ بِالسَّرِّ أَوْ". xxviii ويخالفهم فيه الأئمة الثلاثة، إلا فيما يستثنى من هذا الباب. وحجّة الشافعية في مراعاة الألفاظ دون النيات في العقود، أنّ الحكم بالنيات والمقاصد راجعة إلى الشارع لا إلى آحاد الفقهاء. (قال النووي دبت): "وَإِذَا وَجَدْنَا فِعْلًا مِنَ الْأَفْعَالِ يَقَعُ عَلَى وَجْهِ وَاحِدٍ وَلَا يَخْتَلِفُ إِلَّا بِالنِّيَّةِ مِنْ فَاعِلِهِ وَالْقَصْدِ وَكَانَ ظَاهِرًا وَاجِدًا وَلَمْ يَكُنْ لَنَا طَرِيقٌ إِلَى تَمْيِيزِ مَقَاصِدِ النَّاسِ وَلَا إِلَى تَفْصِيلِ فُصُوْدِهِمْ وَأَعْرَاضِهِمْ وَجَبَ حَسْبُ الْبَابِ وَقَطَعَ النَّظْرَ إِلَيْهِ فَبَدَأَ وَجْهَ بِنَاءِ هَذِهِ الْمَسْأَلَةِ عَلَى التَّرْبِيعَةِ، قَالُوا فَإِنْ سَلِمَ لَنَا هَذَا الْأَصْلُ بَنَيْنَا الْكَلَامَ عَلَيْهِ وَإِنْ لَمْ يَسْلَمْ نَقُلْ الْكَلَامَ إِلَيْهِ هَذَا مَا عَوَّلْتُ عَلَيْهِ الْمَالِكِيَّةُ وَالنَّزَّاعُ مَعَهُمْ فِي هَذَا الْأَصْلِ مَشْهُورٌ فِي الْأَصْلِ وَقَدْ أَقْبَوْنَا كَمَا ظَهَرَ مِنْ كَلَامِهِمْ عَلَى عَدَمِ إِنْطَاةِ الْأَحْكَامِ بِالْمَقَاصِدِ وَوَجُوبِ رِبْطِهَا بِمِظَانِ ظَاهِرٍ فَقَدْ يُوْجِدُ الْقَصْدُ الْفَاسِدُ فِي عَقْدٍ نَتَقُوْا نَحْنُ وَهُمْ عَلَى الْحُكْمِ بِصِحَّتِهِ وَقَدْ يَعْدَمُ الْقَصْدُ الْفَاسِدُ فِي عَقْدٍ يَحْكُمُونَ هُمْ بِفَسَادِهِ وَالْحُكْمُ حِينَئِذٍ بِالْفَسَادِ احْتِكَامٌ بِنَصْبِ شَيْءٍ مُفْسِدٍ وَذَلِكَ مُنْصَبٌ الشَّارِعَ لَيْسَ لِأَخِيذِ الْفُقَهَاءِ اسْتِقْلَالٌ بِهِ فَإِذَا لَمْ يَكُنْ الرُّجُوعُ إِلَى الْمَقَاصِدِ الْحَفِيَّةِ جَائِزًا اتِّقَافًا فَالْأَوَّلَى الْإِعْتِمَادُ عَلَى ظَوَاهِرِ الْعُقُودِ الشَّرْعِيَّةِ وَعَدَمِ الْإِحْتِكَامِ بِأَمْرٍ آخَرَ". xxix

(وقال ابن القيم دبت) في سياق كلامه على الحيل وإبطالها: "ومن أصول الشافعي مراعاة الألفاظ والوقوف معها". xxx والمعارضون لهذا الضابط - ومنهم ابن القيم - يعتمدون على حديث عمر بن الخطاب رضي الله عنه قال سمعت رسول الله صَلَّى اللهُ عَلَيْهِ وَسَلَّمَ يقول: «إِنَّمَا الْأَعْمَالُ بِالنِّيَّاتِ، وَإِنَّمَا لِكُلِّ امْرِئٍ مَا نَوَى...». (البخاري 2001، مسلم دبت) xxxi (قال ابن القيم 1991): "فَأَخْبَرَ أَنَّ الْأَعْمَالَ تَائِبَةً لِمَقَاصِدِهَا وَنِيَّاتِهَا، وَأَنَّهُ لَيْسَ لِلْعَبْدِ مِنْ ظَاهِرِ قَوْلِهِ وَعَمَلِهِ إِلَّا مَا نَوَاهُ وَأَبْطَنَهُ لَا مَا أَعْلَنَهُ وَأَظْهَرَهُ، وَهَذَا نَصٌّ فِي أَنَّ مَنْ نَوَى التَّحْلِيلَ كَانَ مُحْلِلًا، وَمَنْ نَوَى الرِّبَا بَعْدَ التَّبَايُعِ كَانَ رِبَايًّا، وَمَنْ نَوَى الْمَكْرَ وَالْجِدَاعَ كَانَ مَكْرًا مُخَادِعًا". xxxii وقال أيضا (ابن القيم دبت): "ولا ريب أنّ من تدبّر القرآن والسنة، ومقاصد الشارع جزم بتحريم الحيل وبطلانها فإنّ القرآن دلّ على أنّ المقاصد والنيات معتبرة في التصرف والعبادات، كما هي معتبرة في القربات والعبادات، فيجعل الفعل حلالاً أو حراماً، وصحيحاً أو فاسداً، وصحيحاً من وجه، فاسداً من وجه، كما أنّ القصد والنية في العبادات تجعلها كذلك". xxxiii

ولعل الجمع بين الرايين متاح بحمل هذا الضابط على العقود التي لا توجد قرينة ظاهرة فيها تُبَيِّنُ نِيَّةَ الْمُتَعَادِلِينَ، وحمل رأي المخالفين على ما ظهرت فيها نية العاقدين، والله أعلم.

3.3. الضابط الثالث: "البيع بالتراضي". (السمعاني 1999، الرفاعي 1997، حيدر دبت، البركتي 1986) xxxiv

أصل هذا الضابط: قول الله تعالى: (يَا أَيُّهَا الَّذِينَ ءَامَنُوا لَا تَأْكُلُوا أَمْوَالِكُمْ بَيْنَكُمْ بِالْبُطْلِ إِلَّا أَنْ تَكُونَ تِجَارَةً عَنْ تَرَاضٍ مِّنْكُمْ)، [النساء: 29]. ذلك أنّ الآية وردت في سياق تعليق حليّة البيع على التراضي بعد حليّة المبيع وخلوه من الموانع الشرعيّة الأخرى. كنجاسة المبيع وخبثه، وإضراره بالنفس والعقل. وهذا الضابط ذكره (السمعاني 1999) في قواطع الأدلّة في معرض حديثه عن الإجماع وحجّيته، وذلك للاعتراض عليه، ومن ذلك قوله: "وأيضاً فإنّ الإجماع وإن كان عن دليل هو حجة ولكن في الإجماع فائدة وهي أنّ يسقط عنّا البحث عن الحجّة، ويسقط عنّا نقلها ويحرم علينا الخلاف الذي كان سابقاً في مسائل الاجتهاد. وقد قال بعضهم: إنّنا وجدنا إجماعاً منعقداً من غير دليل، نحو إجماعهم على بيع المراضة من غير عقد، والاستبضاع، وأجرة الحماّم، وقطعة الثراب، وأخذ الزكاة من الخيل تبرّءاً، وأخذ الخراج. أورد هذه المسائل أبو الحسين البصري في أصوله. الجواب: أنّ هذه المسائل لم يقع على كلّها الإجماع فإنّ البيع بالتراضي لا يكون بيعاً، ولا بدّ عندنا من الإيجاب والقبول حتى لا يكون ما أخذناه حراماً، وأمّا البيع فلا يقول: إنّّه بالتعاطي المجرد ببعده البيع بحال، وأمّا الاستبضاع فهو على مذهب أبي حنيفة، والباقي من المسائل يجوز أن يسلم كذا نقول إنّ الإجماع لا يقع إلا عن دليل غير أنّه يجوز أن يقع الاكتفاء عن نقل الدليل بوقوع الإجماع". xxxv

الظاهر أن اعتراضه على الضابط في حمله على بيع المعاطاة الذي لا يُجيزُه الشافعية، أما بناءً على البيع على التراضي فهو من شرط صحة البيع الذي لا خلاف فيه، فاعتراضه على الضابط واقع في مسألة خلافية بين الفقهاء، لا يمنع من اطراد الضابط، وقد ورد ذكر هذا الضابط في المادة: 153 من مجلة الأحكام العدلية عند الحديث عن مفهوم الثمن، (حيدر دت) ونص المادة: "الثمن المسمى: هو الذي يُسميه ويُعيّنه العقادان وقت البيع بالتراضي، سواء كان مُطابقاً لقيمتيه الحقيقية أو ناقصاً عنها أو زائداً عليها". xxxvi كما ورد عند (الرافعي 1997) في الشرح الكبير في معرض حديثه عن خيار المجلس للشفيع، ونصه: " الثالثة: في تملك الشفيع الثمن الذي لم يره طريقان: أظهرهما: أنه على قولنا بيع الغائب إن منعناه لم يملكه قبل الرؤية وليس للمشتري منه من الرؤية، وإن صححناه فله التملك... الثاني: المنع سواء صححنا بيع الغائب أو أبطلناه، ولأن البيع بالتراضي فأتينا الخيار فيه وهنا الشفيع يأخذ من غير رضى المشتري فلا يمكن إثبات الخيار فيه". xxxvii

4.3 الضابط الرابع: التراضي في المعاملات المالية لا يُحل حراماً

هذا الضابط تقييد لما قبله، ذلك أن بناء البيع على التراضي يتعلق بحلّية المبيع وخُلُو المعاملة مما يُخلُّ بأركانها أو بشرطه. فالتراضي لا يُبيح المعاملة على الربا، كما أنه لا يُحل بيع الخمر والخنزير والتجاسات ونحوها، لدلالة النصوص الشرعية على تحريم ذلك، مثل قول الله تعالى: (وَأَحَلَّ اللَّهُ الْبَيْعَ وَحَرَّمَ الرِّبَا) (البقرة: 275). وقوله تعالى: (يَا أَيُّهَا الَّذِينَ آمَنُوا اتَّقُوا اللَّهَ وَذَرُوا مَا بَقِيَ مِنَ الرِّبَا إِن كُنتُمْ مُؤْمِنِينَ ٢٧٨)، (البقرة: 278). وما ورد في الصحيحين: عَنْ جَابِرِ بْنِ عَبْدِ اللَّهِ رَضِيَ اللَّهُ عَنْهُمَا، أَنَّهُ سَمِعَ رَسُولَ اللَّهِ صَلَّى اللَّهُ عَلَيْهِ وَسَلَّمَ، يَقُولُ عَامَ الْفَتْحِ وَهُوَ بِمَكَّةَ: «إِنَّ اللَّهَ وَرَسُولَهُ حَرَّمَ بَيْعَ الْخَمْرِ، وَالْمَيْتَةِ وَالْخَنزِيرِ وَالْأَصْنَمِ»، فَقِيلَ: يَا رَسُولَ اللَّهِ، أَرَأَيْتَ شُحُومَ الْمَيْتَةِ، فَأَنَّهَا يُطْلَى بِهَا السُّنُّ، وَيُدْهَنُ بِهَا الْجُلُودُ، وَيَسْتَنْبِخُ بِهَا النَّاسُ؟ فَقَالَ: «لَا، هُوَ حَرَامٌ»، ثُمَّ قَالَ رَسُولُ اللَّهِ صَلَّى اللَّهُ عَلَيْهِ وَسَلَّمَ عِنْدَ ذَلِكَ: «قَاتِلِ اللَّهُ الْيَهُودَ إِنَّ اللَّهَ لَمَّا حَرَّمَ شُحُومَهَا جَمَلُوهَا، ثُمَّ بَاعُوهَا، فَأَكَلُوا ثَمَنَهَا». (البخري 2001، مسلم دت) xxxviii

5.3 الضابط الخامس: "الجهالة مؤثرة في التصرفات المالية". (القرافي 2003) xxxix

هذه قاعدة من القواعد الموثقة عليها بالجملة، وختلفوا في مجالات تطبيقها، فمنهم من عمم تطبيقها في جميع التصرفات المالية، ومنهم من حصر تطبيقها في بعض التصرفات المالية وهي المعاوضات دون التبرعات. وسيأتي تفصيل ذلك في كلام القرافي. ومما يدل على ثبوت القاعدة قول (السرخسي 1993): "إنا إذا جوزنا دخول الحمايم بأجر بطريق الاستحسان فإنما تركنا القول بالفساد الذي يوجب القياس؛ لانعدام علّة الفساد، وهو أن فساد العقد بسبب جهالة المعقود عليه ليس ليعين الجهالة، بل لأنها تقضي إلى منازعة مانعة عن التسليم والتسليم، وهذا لا يوجد هنا وفي نظاره، فكان انعدام الحكم لانعدام العلّة لا أن يكون بطريق تخصيص العلّة". xl فكلما يدور حول ما يستثنى من القاعدة، ومفهومه العمل بالقاعدة في غير مواطن الاستثناء.

من تطبيقات القاعدة: تفاصيل ما ذكره (القرافي 2003) من الخلاف الواقع بين الفقهاء في تطبيق القاعدة، وذلك في "الفرق الرابع والعشرون بين قاعدة ما تؤثر فيه الجهالات والغرر وقاعدة ما لا يؤثر فيه ذلك من التصرفات: وردت الأحاديث الصحيحة في نهيه عليه السلام عن بيع الغرر وعن بيع المجهول، وختلف العلماء بعد ذلك فمنهم من عممه في التصرفات وهو الشافعي فمنع من الجهالة في الهبة والصدقة والإبراء والخلع وغير ذلك، ومنهم من فصل وهو مالك بين قاعدة ما يُجتنب فيه الغرر والجهالة وهو باب المماكسات والتصرفات الموجبة لتنمية الأموال وما يُقصد به تحصيلها، وقاعدة ما لا يُجتنب فيه الغرر والجهالة وهو ما لا يُقصد لذلك، وانقسمت التصرفات عنده لثلاثة: طرفان ووسط، فالطرفان: أحدهما: معاوضة صرقة فيجتنب فيها ذلك إلا ما دعت الضرورة إليه عادة. وثانيهما: ما هو إحسان صرقت لا يُقصد به تنمية المال كالصدقة والهبة والإبراء فإن هذه التصرفات لا يُقصد بها تنمية المال بل إن فائدت على من أحسن إليه بها لا ضرر عليه فإنه لم يبدل شيئاً، بخلاف القسم الأول إذ فادت بالغرر والجهالات ضاع المال المبدول في مقابلته فاقتضت حكمة الشرع منع الجهالة فيه، أما الإحسان الصرقت فلا ضرر فيه فاقتضت حكمة الشرع وحسنه على الإحسان التوسعة فيه بكلّ طريق بالمعروف والمجهول، فإن ذلك أيسر لكثرة وقوعه قطعاً، وفي المنع من ذلك وسيلة إلى تقليبه... ثم إن الأحاديث لم يرد فيها ما يُعم هذه الأقسام حتى نقول يلزم منه مخالفة نصوص صاحب الشرع بل إنما وردت في البيع ونحوه. وأما الوساطة بين الطرفين: فهو الكناخ، فهو من جهة أن المال فيه ليس مقصوداً، وإنما مقصوده المودة والألفة والسكون يقتضي أن يجوز فيه الجهالة والغرر مطلقاً، ومن جهة أن صاحب الشرع اشترط فيه المال بقوله تعالى: (أَنْ تَتَّبِعُوا بِأَمْوَالِكُمْ)، [النساء: 24]، يقتضي امتناع الجهالة والغرر فيه، فلو وُجد الشبهان توسطاً لمالك فحوز فيه الغرر القليل دون الكثير". xli

ومن فروع هذه القاعدة، قاعدة: "الجهالة مانعة من صحة عقد البيع والإجارة ونحوهما". (القرافي 2003) xliii وهذه القاعدة ذكرها القرافي في المثال الثالث تحت الفرق الثمانين، واستثنى منها: الجعالة والعارية والقراض. فقال: "وهي شرط في الجعالة والعارية والقراض، فلا تجوز إلى يوم معلوم، لأن المطلوب قد لا يحصل في ذلك الأجل، فاقتضت مصلحة هذه العقود أن يكون الأجل مجهولاً، ولذلك لا يجوز أن يحدّد لخياطة الثوب وغيره من الإجازات يوماً معلوماً، لأنه يوجب الغرر، ويفوت المصلحة، بل المصلحة تقتضي بقاء الأجل مجهولاً". (القرافي 2003) xliv

وقاعدة: "الجهالة تُوجب الإخلال بمصالح العقود في البياعات، وأكثر أنواع الإجازات". (القرافي 2003) xlv وهذه القاعدة أوردتها القرافي تحت الفرق الثامن والمنتين: بين قاعدة ما يمنع فيه الجهالة وبين قاعدة ما لا يشترط فيه الجهالة بحيث لو فقدت فيه الجهالة فسدت. فقال (القرافي 2003): "وجودها يوجب تحصيل مصلحة عقد الجعالة حتى يبقى المجمعول له على طلبه". xlv وكل ما يخل بمصالح البياعات فهو مبطل لها؛ لأن مصلحة الانتفاع في البياعات هي المقصودة، ومن ثم فإن الإخلال بها إخلال بالمعاملة نفسها فلا تصح.

6.3 الضابط السادس: "كل قرض جر نفعاً فهو ربا"

أصل هذا الضابط حديث روي مرفوعاً وموقوفاً عن علي، وابن مسعود، وابن عباس، وقصالة بن عبيد رضي الله عنهم أجمعين: «كُلُّ قَرْضٍ جَرَّ مَنَفَعَةً فَهُوَ رِبَا»، (ابن أبي أسامة 1992، البيهقي 1989) xlvi فمن أقرض شخصاً واشترط عليه بسبب ذلك القرض منفعَةً لنفسه فإن ذلك يعتبر من الربا المحرم، وقد اتفق الفقهاء على ذلك إلا في بعض الأمثلة التي لا يراها بعض الحنابلة داخلة تحت الحديث كما سيأتي بيانه. ومما ورد في تطبيقاته قول (الكاساني 1986): "لو قال له: خذ هذه الألف على أن يصفها قرض عليك على أن تعمل بالصف الأخر مُضَارَبَةً على أن الربح لي فهذا مكروه؛ لأنه شرط لنفسه منفعَةً في مقابلة القرض، وقد «نهى رسول الله - صلى الله عليه وسلم - عن قرض جر نفعاً»، فإن عمل على هذا فريخ أو وضع فالربح بينهما نصفان، وكذا الوضعية". xlvii وقال في موضع آخر (الكاساني 1986): "(وَأَمَّا الَّذِي يَرْجِعُ إِلَى نَفْسِ الْقَرْضِ: فَهُوَ أَنْ لَا يَكُونَ فِيهِ جَرٌّ مَنَفَعَةٍ، فَإِنْ كَانَ لَمْ يَجَزْ، نَحْوُ مَا إِذَا أَقْرَضَهُ دَرَاهِمَ غَلَّةٍ، عَلَى أَنْ يَرُدَّ عَلَيْهِ صَحَاخًا، أَوْ أَقْرَضَهُ وَشَرَطَ شَرْطًا لَهُ فِيهِ مَنَفَعَةٌ؛ لِمَا رَوَى عَنْ رَسُولِ اللَّهِ - صَلَّى اللَّهُ عَلَيْهِ وَسَلَّمَ - أَنَّهُ «نَهَى عَنْ قَرْضٍ جَرَّ نَفَعًا»؛ وَلِأَنَّ الزِّيَادَةَ الْمَشْرُوطَةَ تُشْبِهُ الرِّبَا؛ لِأَنَّهَا فَضْلٌ لَا يُقَابَلُهُ عَوْضٌ، وَالتَّحَرُّرُ عَنْ حَقِيقَةِ الرِّبَا، وَعَنْ شَبْهَةِ الرِّبَا وَاجِبٌ هَذَا إِذَا كَانَتْ الزِّيَادَةُ مَشْرُوطَةً فِي الْقَرْضِ، فَأَمَّا إِذَا كَانَتْ غَيْرَ مَشْرُوطَةٍ فِيهِ وَلَكِنَّ الْمُسْتَقْرَضَ أَعْطَاهُ أَحْوَدَهُمَا؛ فَلَا بَأْسَ بِذَلِكَ؛ لِأَنَّ الرِّبَا اسْمٌ لِزِيَادَةِ مَشْرُوطَةٍ فِي الْعَقْدِ، وَلَمْ تَوْجَدْ، بَلْ هَذَا مِنْ بَابِ حُسْنِ الْقَضَاءِ، وَأَنَّهُ أَمْرٌ مُنْدُوبٌ إِلَيْهِ قَالَ النَّبِيُّ - عَلَيْهِ السَّلَامُ -: «إِنَّ خِيَارَكُمْ أَحْسَنُكُمْ قَضَاءً». (البخري 2001) xlviii

وقال (البغوي 1983): "قَالَ أَحْمَدُ: هُوَ أَنْ يَفْرُضَهُ قَرْضًا، ثُمَّ يُبَاعُهُ عَلَيْهِ بَيْعًا يَزِدَادُ عَلَيْهِ، وَلَوْ قَالَ: أَفْرَضْتُكَ هَذِهِ الْعَشْرَةَ عَلَى أَنْ تَبْعِي عِبْدَكَ فَفَاسِدٌ، لِأَنَّ كُلَّ قَرْضٍ جَرٌّ مُنْفَعَةٌ فَهُوَ رَبًّا"¹.

ويدخل في ذلك السفاتح عند الحنفية والشافعية، وهي قرض استقاده به المقرض سقوط خطر الطريق. (المرغيباني د.ت) li (قال النووي د.ت): "ولا يجوز أن يقرضه دراهم على أن يعطيه بدلها في بلد آخر، ويكتب له بها صحيفة (كمبيالة) فيأمن خطر الطريق ومثونة الحمل، وهو مذهبنا، وخالفنا أحمد وغيره مستدلين بأن عبد الله بن الزبير كان يقترض ويعطي من أقرضه صحيفة يأخذ قيمتها من مصعب أخيه واليه على العراق". liii ودليل منعه أن أمن الطريق منفعة، وكل قرض جر منفعة فهو ربا. (النووي د.ت) liiii ويرى الإمام أحمد جواز إعطاء المقرض من أقرضه صحيفة يأخذ قيمتها في بلد آخر، اعتماداً على فعل عبد الله بن الزبير رضي الله عنهما. ولأن هذا عقد إرفاق فيجوز. يدل على ذلك ما ورد في "دليل الطالب لنيل المطالب" من كتب الحنابلة (مرعي بن يوسف 2004): "وكل قرض جر نفعاً فحرام كأن يسكنه داره أو يعيره دابته أو يقضيه خيراً منه فإن فعل ذلك بلا شرط أو قضى خيراً منه بلا مواطاة جاز. ومتى بذل المقرض ما عليه بغير بلد المقرض ولا مؤنة لحمله لزم". liv

4. أثر هذه الضوابط في الصيرفة الإسلامية

من أبرز آثار الضوابط المذكورة على الصيرفة الإسلامية ما يلي:

1.4. ترشيد العملية المصرفية نحو المعاملات المالية المباحة شرعاً

ذلك أن هذه الضوابط عبارة عن آليات ترشيد لعملية الصيرفة الإسلامية نحو المنهج الإسلامي في تنمية المال واستثماره بما يخدم الأمة ويحقق لها مكانتها وتميزها في مجال المعاملات المالية بصفة عامة والصيرفة الإسلامية بصفة خاصة.

2.4. الابتعاد عن شبهة الربا في الصيرفة الإسلامية

ذلك أن الضوابط المذكورة عبارة عن سياج يحمي عملية الصيرفة الإسلامية من الوقوع في مزالق الحيل والشبهات الربوية، واستغلال حاجة الناس واضطرارهم، ويقيّد عملية الصيرفة الإسلامية بأخلاقيات الإسلام في المعاملات المالية، التي هي الرفق والسماحة والتعاون. كما ثبت عن جابر رضي الله عنهما قال: قال رسول الله صلى الله عليه وسلم: «رَحِمَ اللَّهُ رَجُلًا سَمَحًا إِذَا بَاعَ وَإِذَا اشْتَرَى». (البخاري 2001، ابن حبان د.ت) 17 وكما ورد في صحيح مسلم عن عائشة، رضي الله عنها، عن النبي صلى الله عليه وسلم، قال: «إِنَّ الرَّفْقَ لَا يَكُونُ فِي شَيْءٍ إِلَّا زَانَهُ وَلَا يُزْرَعُ مِنْ شَيْءٍ إِلَّا شَانُهُ». (مسلم د.ت) 1vi وعَنْ أَبِي حَيَّانَ النَّبِيِّ عَنْ أَبِيهِ، قَالَ: قَالَ رَسُولُ اللَّهِ صَلَّى اللَّهُ عَلَيْهِ وَسَلَّمَ: «يَدُ اللَّهِ عَلَى الشَّرِيكَيْنِ مَا لَمْ يَخُنْ أَحَدُهُمَا صَاحِبَهُ، فَإِذَا خَانَ أَحَدُهُمَا صَاحِبَهُ رَفَعَهَا عَنْهُمَا». (الدارقطني 2004) 1vii أي: مههما بالمعونة وحصول البركة والنماء.

3.4. كسب ثقة العملاء الصيرفة الإسلامية

ذلك أن الضوابط المذكورة عبارة ضمان ثقة العملاء للمصارف الإسلامية، مما يفتح آفاقاً رحباً وفرصاً متعددة للمصارف الإسلامية في كسب أكبر عدد من العملاء المسلمين؛ أفراداً، وشركات ومؤسسات استثمارية أو صناعية.

4.4. تحقيق أهداف المصارف الإسلامية التي أسست من أجلها

ذلك أن الضوابط المذكور كلها تؤكد على التزام المصارف الإسلامية بالمعاملات المالية المبنية على الشراكة في الربح والخسارة، التي هي أسس تأسيس المصارف الإسلامية، والتي بها يمكن للمصارف الإسلامية المساهمة في التنمية المستدامة في المجتمعات المسلمة.

5.4. تمكين المصارف الإسلامية من توسيع خدماتها بما يتفق مع الضوابط الإسلامية

ذلك أن الضوابط المذكور تضع عملية الصيرفة الإسلامية في إطارها المنهجي الإسلامي الصحيح، وتسهم في توسيع نطاق الخدمات المصرفية كماً وكيفاً وفق متطلبات الأمة وحاجات العصر.

6.4. إضفاء صفة التميز على المصارف الإسلامية

ذلك أن التزام المصارف الإسلامية بالضوابط المذكورة تضي عليها صفة التميز في مجال العملية المصرفية، وتوهمها للمنافسة الشريفة في أسواق الصيرفة والأعمال.

5. خاتمة

لقد ناقش البحث موضوع الضوابط الأساسية للمعاملات المالية وأثرها في الصيرفة الإسلامية، فتوصل إلى ما يلي:
إن المعاملات المالية شرعت لسد حاجات الناس التي لا يمكن أن تتحقق إلا بهذه المعاملات، وهي إما معاوضات أو تبرعات. وقد روعى في تشريعها مقاصد الشريعة في جلب المصالح ودرء المفاسد.

أعمال المصارف الإسلامية تكتنفها شبهات وجب، مما يقلل من مصداقيتها، والتزامها بأحكام الشريعة الإسلامية في المعاملات المالية. وقد تبين في البحث أنه من أجل وضع أعمال المصارف الإسلامية في مسارها الإسلامي الصحيح، يجب أن تلتزم بالضوابط الفقهية المتعلقة بالمعاملات المالية، كالتحري في حلية المعاملة، والابتعاد عن الشبهات والحيل، والتزام الوضوح والشفافية في المعاملات، وعدم استغلال حاجة الناس إن الالتزام بالضوابط الفقهية في المعاملات المالية له أثر كبير في الصيرفة الإسلامية، من حيث الترشيد، وكسب ثقة المسلمين، وتحقيق الأهداف المرجوة من المصارف الإسلامية في الابتعاد عن الربا والمساهمة في التنمية المستدامة، من خلال توسيع خدماتها وفق الضوابط الشرعية، مما يؤهلها للتميز في مجال العملية المصرفية.

i - ابن القيم، محمد بن أبي بكر. (د.ت). إغاثة اللفهان من مصائد الشيطان، تحقيق محمد حامد الفقي، د.ط. الرياض: مكتبة المعارف، ج1، ص 339.

- ii - ابن تيمية، أحمد بن عبد الحلیم. (1987م). **الفتاوى الكبرى**، ط1. بيروت: دار الكتب العلمية، ج4، ص19.
- iii - انظر: ابن القيم، محمد بن أبي بكر. (1991م). **إعلام الموقعين عن رب العالمين**، تحقيق محمد عبد السلام إبراهيم، ط1. بيروت: دار الكتب العلمية، ج1، ص169.
- iv - ابن القيم، **إعلام الموقعين عن رب العالمين**، ج1، ص218.
- v - انظر: البخاري، محمد بن إسماعيل. (2001). **صحيح البخاري**، تحقيق محمد زهير بن ناصر، ط1. بيروت: دار طوق النجاة، كتاب تفسير القرآن، **بَابُ قَوْلِهِ: {وَعَلَى الَّذِينَ هَانُوا حَرْمًا كُلَّ ذِي ظُفْرٍ، وَمِنَ الْبَقَرِ وَالْعَنَمِ حَرْمًا عَلَيْهِمْ شَحُومُهُمَا} [الأنعام: 146]** الآية، ج6، ص57. ومسلم بن الحجاج. (د.ت). **صحيح مسلم**، تحقيق محمد فؤاد عبد الباقي، د.ط. بيروت: دار إحياء التراث العربي، **كِتَابُ الْمَسَاقَاةِ، بَابُ تَحْرِيمِ بَيْعِ الْخَمْرِ، وَالْمَيْتَةِ، وَالْخَزِيرِ، وَالْأَصْنَامِ**، ج3، ص1208. واللفظ لمسلم.
- vi - ابن القيم، **إعلام الموقعين عن رب العالمين**، ج3، ص92.
- vii - ابن القيم، **إعلام الموقعين عن رب العالمين**، ج3، ص93.
- viii - انظر: ابن القيم، **إغائة اللهفان من مصاديق الشيطان**، ج1، ص352.
- ix - ابن تيمية، أحمد بن عبد الحلیم. (1987م). **الفتاوى الكبرى**، ط1. بيروت: دار الكتب العلمية، ج6، ص151.
- x - ابن القيم، محمد بن أبي بكر. (1993م). **الفروسية**، تحقيق مشهور بن حسن، ط1. حائل - السعودية: دار الأندلس، ص168.
- xi - أبو داود، سليمان بن الأشعث. (د.ت). **سنن أبي داود**، تحقيق محمد محيي الدين عبد الحميد، د.ط. بيروت: المكتبة العصرية، كتاب البيوع، **بَابُ فِي الرَّجُلِ يَبِيعُ مَا لَيْسَ عِنْدَهُ**، ج3، ص283. وصححه الألباني. والترمذي، محمد بن عيسى. (1998م). **سنن الترمذي**، تحقيق بشار عواد معروف، د.ط. بيروت: دار الغرب الإسلامي، **أبواب البيوع**، **بَابُ مَا جَاءَ فِي كَرَاهِيَةِ بَيْعِ مَا لَيْسَ عِنْدَكَ**، ج2، ص525. وقال الترمذي: هذا حديث حسن صحيح.
- xii - أبو داود، سليمان بن الأشعث. (د.ت). **سنن أبي داود**، تحقيق محمد محيي الدين عبد الحميد، كتاب البيوع، **بَابُ فِيمَنْ بَاعَ بَيْعَتَيْنِ فِي بَيْعَةٍ**، ج3، ص274. وحسنه الألباني.
- xiii - انظر: الصنعاني، محمد بن إسماعيل. (د.ت). **سبل السلام**، د.ط. مصر: دار الحديث، ج2، ص20. والشوكاني، محمد بن علي. (1993). **نيل الأوطار**، تحقيق عصام الدين الصباطي، ط1. مصر: دار الحديث، ج5، ص181. والعظيم آبادي، محمد أشرف. (1985). **عون المعبود شرح سنن أبي داود**، ومعه حاشية ابن القيم: تهذيب سنن أبي داود وإيضاح علله ومشكلاته، ط2. بيروت: دار الكتب العلمية، ج9، ص247.
- xiv - والشوكاني، محمد بن علي. (1993). **نيل الأوطار**، ج5، ص181. والعظيم آبادي، محمد أشرف. (1985). **عون المعبود شرح سنن أبي داود**، ومعه حاشية ابن القيم: تهذيب سنن أبي داود وإيضاح علله ومشكلاته، ج9، ص247.
- xv - العظيم آبادي، محمد أشرف. (1985). **عون المعبود شرح سنن أبي داود**، ومعه حاشية ابن القيم: تهذيب سنن أبي داود وإيضاح علله ومشكلاته، ج9، ص247.
- xvi - ابن القيم، محمد بن أبي بكر. (د.ت). **الطرق الحكمية**، د.ط. مكتبة دار البيان، ص203.
- xvii - ابن بطة، عبيد الله بن محمد. (1983م). **إبطال الحيل**، تحقيق زهير الشاويش، ط2. بيروت: المكتبة الإسلامية، ص46. وحسنه الألباني.
- xviii - الحجاوي، موسى بن أحمد. (د.ت). **الإقناع في فقه الإمام أحمد بن حنبل**، تحقيق عبد اللطيف محمد موسى السبكي، د.ط. بيروت: دار المعرفة، ج4، ص376.
- xix - انظر: ابن عابدين، محمد أمين بن عمر (1992م). **حاشية رد المحتار على الدر المختار**، ط2. بيروت: دار الفكر، ج1، ص371.
- xx - انظر: زروق، أحمد بن أحمد بن محمد. (2006م). **شرح زروق على متن الرسالة لابن أبي زيد القيرواني**، تحقيق أحمد فريد المزيدي، ط1. بيروت: دارا لكتب العلمية، ج2، ص1112.
- xxi - انظر: الشنقيطي، محمد بن محمد سالم. (2015م). **لوامع الدرر في هتك استار المختصر**، ط1. نواكشوط: دار الرضوان، ج1، ص571.
- xxii - انظر: ابن حجر الهيتمي، أحمد بن محمد بن علي. (1983م). **تحفة المحتاج في شرح المنهاج**، د.ط. مصر: المكتبة التجارية الكبرى، ج10، ص112. وعز الدين بن عبد السلام. (2016م). **الغاية في اختصار النهاية**، تحقيق إباد خالد الطباع، ط1. بيروت: دار النوادر، ج1، ص90.
- xxiii - انظر: أبو البركات مجد الدين عبد السلام بن عبد الله بن تيمية. (1984م). **المحرر في الفقه على مذهب الإمام أحمد بن حنبل**، ط2. الرياض: مكتبة المعارف، ج2، ص262. وابن مفلح، إبراهيم بن محمد. (1984م). **النكت والفوائد السننية على مشكل المحرر**، ط2. الرياض: مكتبة المعارف، ج2، ص262.
- xxiv - المرادوي، علي بن سليمان. (د.ت). **الإنصاف في معرفة الراجح من الخلاف**، ط2. بيروت: دار إحياء التراث العربي، ج11، ص196.
- xxv - المرادوي، **الإنصاف**، ج12، ص50.

- xxvi - البخاري، صحيح البخاري، تحقيق محمد زهير بن ناصر، كتاب الإيمان، باب: {فَإِنْ تَأْتُوا وَاقَامُوا الصَّلَاةَ وَآتَوُا الزَّكَاةَ فَخَلُّوا سَبِيلَهُمْ} [التوبة: 5]، ج1، ص14. ومسلم بن الحجاج، صحيح مسلم، تحقيق محمد فؤاد عبد الباقي، كتاب الإيمان، بابُ الأمرِ بِقِتَالِ النَّاسِ حَتَّى يَفُوتُوا: لَا إِلَهَ إِلَّا اللَّهُ مُحَمَّدٌ رَسُولُ اللَّهِ، ج1، ص51.
- xxvii - البخاري، صحيح البخاري، كتاب، بابُ مؤَظَّةِ الإِمَامِ لِلْخُصُومِ، ج9، ص69.
- xxviii - البيهقي، أحمد بن الحسين. (1991م). معرفة السنن والآثار، تحقيق عبد المعطي أمين قلجعي، ط1. دمشق: دار فتيية، ج11، ص158.
- xxix - النووي، يحيى بن شرف. (د.ت). المجموع شرح المهذب، د.ط. بيروت: دار الفكر، ج10، ص155.
- xxx - ابن القيم، محمد بن أبي بكر. (د.ت). بدائع الفوائد، د.ط. بيروت: دار الكتاب العربي، ج4، ص32.
- xxxi - البخاري، صحيح البخاري، با بدء الوحي، كَيْفَ كَانَ بَدْءُ الْوَحْيِ إِلَى رَسُولِ اللَّهِ صَلَّى اللَّهُ عَلَيْهِ وَسَلَّمَ؟ ج1، ص6. وكتاب الأيمان والنور، بابُ النِّيَّةِ فِي الْإِيْمَانِ، ج8، ص140. وكتاب الحيل، بابُ فِي تَرْكِ الْحَيْلِ، وَأَنَّ لِكُلِّ أَمْرٍ مَا تَوَى فِي الْإِيْمَانِ وَغَيْرَهَا، ج9، ص22. ومسلم، صحيح مسلم، كتابُ الإِمَارَةِ، بابُ قَوْلِهِ صَلَّى اللَّهُ عَلَيْهِ وَسَلَّمَ: «إِنَّمَا الْأَعْمَالُ بِالنِّيَّةِ»، وَأَنَّهُ يَدْخُلُ فِيهِ الْعَزُّ وَغَيْرُهُ مِنَ الْأَعْمَالِ، ج3، ص1515.
- xxxii - ابن القيم، إعلام الموقعين، ج3، ص130.
- xxxiii - ابن القيم، إغائة اللهفان من مصادب الشيطان، ج1، ص377.
- xxxiv - السمعاني، أبو المظفر منصور بن محمد بن عبد الجبار بن أحمد المروزي. (1999م). قواطع الأدلة في الأصول. تحقيق محمد حسن إسماعيل الشافعي، ط1. بيروت: دار الكتب العلمية. ص470 - 471. والرافعي القزويني، عبد الكريم بن محمد. (1417 هـ / 1997م). الشرح الكبير: "فتح العزيز بشرح الوجيز"، تحقيق علي محمد معوض، وعادل أحمد عبد الموجود، ط1. بيروت: دار الكتب العلمية. كتاب الشفعة، الباب الثاني في كفيّة الأخذ بالشفعة. ج5. ص507. وحيدر، علي. (د.ت). درر الحكام شرح مجلة الأحكام، تحقيق المحامي فهمي الحسيني (محقق). د.ط. بيروت: دار الكتب العلمية، ج1. 107. وج2. ص473. والبركتي، محمد عميم الإحسان المجددي. (1986م). قواعد الفقه. د.ط. كراتشي: الصدف ببلشرز. ص243-244.
- xxxv - السمعاني، قواطع الأدلة في الأصول. محمد حسن إسماعيل الشافعي (محقق). مرجع سابق. ص470 - 471.
- xxxvi - حيدر، علي. (د.ت). درر الحكام شرح مجلة الأحكام. تحقيق المحامي فهمي الحسيني، ج1. 107. وج2. ص473. والبركتي، محمد عميم الإحسان المجددي. (1986م). قواعد الفقه، ص243-244.
- xxxvii - الرافعي القزويني، الشرح الكبير: "فتح العزيز بشرح الوجيز". تحقيق علي محمد معوض، وعادل أحمد عبد الموجود، كتاب الشفعة، الباب الثاني في كفيّة الأخذ بالشفعة. ج5. ص507.
- xxxviii - البخاري، صحيح البخاري، كتاب البيوع، بابُ بَيْعِ الْمَيْتَةِ وَالْأَصْنَامِ، ج3، ص84. ومسلم، صحيح مسلم، كتابُ الْمُسَاقَاةِ، بابُ تَحْرِيمِ بَيْعِ الْخَمْرِ، وَالْمَيْتَةِ، وَالْخُزَيْرِ، وَالْأَصْنَامِ، ج3، ص1207.
- xxxix - القرافي، أحمد بن إدريس الصنهاجي أبو العباس. (2003م). الفروق. تحقيق عمر حسن القيام، ط1. بيروت: مؤسسة الرسالة، ج1. ص347.
- xl - السرخسي، شمس الدين أبو بكر محمد بن أبي سهل. (1993م). أصول السرخسي. ط1. بيروت: دار الكتب العلمية. ج2. ص208.
- xli - القرافي، أحمد بن إدريس الصنهاجي أبو العباس. (2003م). الفروق. تحقيق عمر حسن القيام، ج1. ص347-349.
- xlii - القرافي، الفروق، ج2. ص212.
- xliii - القرافي، الفروق ج2. ص212.
- xliv - نفسه. ج4. ص28.
- xlvi - القرافي، الفروق، ج4. ص28.
- xlvi - ابن أبي أسامة، الحارث بن محمد. (1992م). بغية الباحث عن زوائد مسند الحارث، تحقيق حسين أحمد صالح الباكري، ط1. المدينة المنورة: مركز خدمة السنة النبوية، بابُ فِي الْفَرْضِ يَجْرُ الْمُنْفَعَةُ، ج1، ص500. والبيهقي، أحمد بن الحسين. (1989م). السنن الصغرى، تحقيق عبد المعطي أمين قلجعي، د.ط. كراتشي: جامعة الدراسات الإسلامية، باب القرض، ج2، ص273.
- xlvi - الكاساني، أبو بكر بن مسعود. (1986م). بدائع الصنائع في ترتيب الشرائع، ط2. بيروت: دار الكتب العلمية، ج6، ص83.
- xlvi - البخاري، صحيح البخاري، كتاب المساقاة، بابُ حُسْنِ الْقَضَاءِ، ج3، ص117.
- xlix - الكاساني، بدائع الصنائع، ج7، ص395.
- l - البغوي، الحسين بن مسعود. (1983م). شرح السنة، تحقيق الأرنؤوط، شعيب، ومحمد زهير الشاويش، ط2. دمشق: المكتب الإسلامي، ج8، ص145.
- li - المرغيناني، علي بن أبي بكر. (د.ت). الهداية شرح بداية المبتدي، تحقيق طلال يوسف، د.ط. بيروت: دار إحياء التراث العربي، ج3، ص100.
- lii - النووي، المجموع، ج13، ص172.

- liii - النووي، **المجموع**، ج13، ص172.
- liv - مرعي بن يوسف المقدسي الحنبلي. (2004م). **دليل الطالب لنيل المطالب**، تحقيق أبو قتيبة نظر محمد الفارابي، ط1. الرياض، دار طيبة للنشر والتوزيع، ص138.
- lv - البخاري، **صحيح البخاري**، كتاب البيوع. باب السهولة والسماحة في الشراء والبيع، ومن طلب حقا فليطلبه في عفاف. ج2. ص730. وابن حبان. (د.ت). **صحيح ابن حبان**. تحقيق شعيب الأرنؤوط. (د.ط). بيروت: مؤسسة الرسالة. كتاب البيوع. ونصه: «رحم الله عبدا سمحا إذا باع سمحا إذا اشترى سمحا إذا اقتضى». ج11. ص267.
- lvi - مسلم، **صحيح مسلم**، كتاب البر والصلة. باب فضل الرفق. ج8. ص22.
- lvii - الدارقطني، أبو الحسن علي بن عمر بن أحمد. (2004م). **سنن الدارقطني**. شعيب الأرنؤوط وآخرون (محقق). د.ط. بيروت: مؤسسة الرسالة. كتاب البيوع. ج3. ص442.

المصادر والمراجع

- القرآن الكريم
- ابن أبي أسامة، الحارث بن محمد. (1992م). **بغية الباحث عن زوائد مسند الحارث**، تحقيق حسين أحمد صالح الباكري، ط1. المدينة المنورة: مركز خدمة السنة النبوية.
- البخاري، محمد بن إسماعيل. (2001). **صحيح البخاري**، تحقيق محمد زهير بن ناصر، ط1. بيروت: دار طوق النجاة.
- أبو البركات مجد الدين عبد السلام بن عبد الله بن تيمية. (1984م). **المحرر في الفقه على مذهب الإمام أحمد بن حنبل**، ط2. الرياض: مكتبة المعارف.
- البركتي، محمد عميم الإحسان المجددي. (1407هـ / 1986م). **قواعد الفقه**. د.ط. كراتشي: الصدف ببلشرز.
- ابن بطّة، عبيد الله بن محمد. (1983م). **إبطال الحيل**، تحقيق زهير الشاويش، ط2. بيروت: المكتب الإسلامي.
- البغوي، الحسين بن مسعود. (1983م). **شرح السنة**، تحقيق الأرنؤوط، شعيب، ومحمد زهير الشاويش، ط2. دمشق: المكتب الإسلامي.
- البيهقي، أحمد بن الحسين. (1989م). **السنن الصغرى**، تحقيق عبد المعطي أمين قلجعي، د.ط. كراتشي: جامعة الدراسات الإسلامية.
- البيهقي، أحمد بن الحسين. (1991م). **معرفة السنن والآثار**، تحقيق عبد المعطي أمين قلجعي، ط1. دمشق: دار قتيبة.
- الترمذي، محمد بن عيسى. (1998م). **سنن الترمذي**، تحقيق بشار عواد معروف، د.ط. بيروت: دار الغرب الإسلامي.
- ابن تيمية، أحمد بن عبد الحلیم. (1987م). **الفتاوى الكبرى**، ط1. بيروت: دار الكتب العلمية.
- ابن حبان. (د.ت). **صحيح ابن حبان**. تحقيق شعيب الأرنؤوط. (د.ط). بيروت: مؤسسة الرسالة.
- ابن حجر الهيتمي، أحمد بن محمد بن علي. (1983م). **تحفة المحتاج في شرح المنهاج**، د.ط. مصر: المكتبة التجارية الكبرى.
- الحجاوي، موسى بن أحمد. (د.ت). **الإقناع في فقه الإمام أحمد بن حنبل**، تحقيق عبد اللطيف محمد موسى السبكي، د.ط. بيروت: دار المعرفة.
- حيدر، علي. (د.ت). **درر الحکام شرح مجلة الأحكام**. تحقيق المحامي فهمي الحسيني (محقق). د.ط. بيروت: دار الكتب العلمية.
- الدارقطني، أبو الحسن علي بن عمر بن أحمد. (2004م). **سنن الدارقطني**. شعيب الأرنؤوط وآخرون (محقق). د.ط. بيروت: مؤسسة الرسالة.

- أبو داود، سليمان بن الأشعث. (د.ت). سنن أبي داود، تحقيق محمد محيي الدين عبد الحميد، د.ط. بيروت: المكتبة العصرية.
- الرافعي القزويني، عبد الكريم بن محمد. (1997م). الشرح الكبير: "فتح العزيز بشرح الوجيز". علي محمد معوض، وعادل أحمد عبد الموجود (محقق). ط1. بيروت: دار الكتب العلمية.
- زروق، أحمد بن أحمد بن محمد. (2006م). شرح زروق على متن الرسالة لابن أبي زيد القيرواني، تحقيق أحمد فريد المزيدي، ط1. بيروت: دار الكتب العلمية.
- السرخسي، شمس الدين أبو بكر محمد بن أبي سهل. (1993م). أصول السرخسي. ط1. بيروت: دار الكتب العلمية.
- السمعاني، أبو المظفر منصور بن محمد بن عبد الجبار بن أحمد المروزي. (1999م). قواطع الأدلة في الأصول. محمد حسن إسماعيل الشافعي (محقق). ط1. بيروت: دار الكتب العلمية.
- الشنقيطي، محمد بن محمد سالم. (2015م). لوامع الدرر في هتك استار المختصر، ط1. نواكشوط: دار الرضوان.
- الشوكاني، محمد بن علي. (1993). نيل الأوطار، تحقيق عصام الدين الصبابي، ط1. مصر: دار الحديث.
- الصنعاني، محمد بن إسماعيل. (د.ت). سبل السلام، د.ط. مصر: دار الحديث.
- ابن عابدين، محمد أمين بن عمر (1992م). حاشية رد المحتار على الدر المختار، ط2. بيروت: دار الفكر.
- عز الدين بن عبد السلام. (2016م). الغاية في اختصار النهاية، تحقيق إياد خالد الطباع، ط1. بيروت: دار النوادر.
- العظيم آبادي، محمد أشرف. (1985). عون المعبود شرح سنن أبي داود، ومعه حاشية ابن القيم: تهذيب سنن أبي داود وإيضاح علله ومشكلاته، ط2. بيروت: دار الكتب العلمية.
- القرافي، أحمد بن إدريس الصنهاجي أبو العباس. (2003م). الفروق. تحقيق عمر حسن القيّام. ط1. بيروت: مؤسسة الرسالة.
- ابن القيم، محمد بن أبي بكر. (1991م). إلام الموقعين عن رب العالمين، تحقيق محمد عبد السلام إبراهيم، ط1. بيروت: دار الكتب العلمية.
- ابن القيم، محمد بن أبي بكر. (د.ت). إغاثة اللفهان من مصاديد الشيطان، تحقيق محمد حامد الفقي، د.ط. الرياض: مكتبة المعارف.
- ابن القيم، محمد بن أبي بكر. (د.ت). الطرق الحكيمة، د.ط. مكتبة دار البيان.
- ابن القيم، محمد بن أبي بكر. (1993م). الفروسيّة، تحقيق مشهور بن حسن، ط1. حائل – السعودية: دار الأندلس.
- الكاساني، أبو بكر بن مسعود. (1986م). بدائع الصنائع في ترتيب الشرائع، ط2. بيروت: دار الكتب العلمية.
- المرداوي، علي بن سليمان. (د.ت). الإنصاف في معرفة الراجح من الخلاف، ط2. بيروت: دار إحياء التراث العربي.
- مرعي بن يوسف المقدسي الحنبلي. (2004م). دليل الطالب لنيل المطالب، تحقيق أبو قتيبة نظر محمد الفارابي، ط1. الرياض، دار طيبة للنشر والتوزيع.
- المرغيناني، علي بن أبي بكر. (د.ت). الهداية شرح بداية المبتدي، تحقيق طلال يوسف، د.ط.

بيروت: دار إحياء التراث العربي.
مسلم بن الحجاج. (د.ت). **صحيح مسلم**، تحقيق محمد فؤاد عبد الباقي، د.ط. بيروت: دار إحياء
التراث العربي.
ابن مفلح، إبراهيم بن محمد. (1984م). **النكت والفوائد السننية على مشكل المحرر**، ط2.
الرياض: مكتبة المعارف.
النووي، يحيى بن شرف. (د.ت). **المجموع شرح المهذب**، د.ط. بيروت: دار الفكر.