

PAPER • OPEN ACCESS

A Novel Innovation Design of Advanced Sublimation Printing Machine

To cite this article: M N Masri *et al* 2021 *IOP Conf. Ser.: Earth Environ. Sci.* **765** 012088

View the [article online](#) for updates and enhancements.

You may also like

- [Discrete-event simulation of a production process for increasing the efficiency of a newspaper production](#)
O Riskadayanti, Yuniaristanto, W sutopo et al.
- [Torsional Vibration Modeling and Simulation of Printing Cylinder in Printing Machine](#)
Yiming Wang, Xin Liu, Shuqin Wu et al.
- [Research on torsional vibration modelling and control of printing cylinder based on particle swarm optimization](#)
Y M Wang, W C Xu, S Q Wu et al.



The Electrochemical Society
Advancing solid state & electrochemical science & technology

241st ECS Meeting

May 29 – June 2, 2022 Vancouver • BC • Canada

Extended abstract submission deadline: Dec 17, 2021

Connect. Engage. Champion. Empower. Accelerate.
Move science forward



Submit your abstract



A Novel Innovation Design of Advanced Sublimation Printing Machine

M N Masri^{1,*}, A Hamid², M Mohamed¹, M Mohamad¹ and S A Sobri¹

¹ Faculty of Bioengineering and Technology, Universiti Malaysia Kelantan, 17600 Jeli Kelantan, Malaysia

² Azrain Collection and Trading, 723 B, Tingkat Bawah, Wisma Haminah, Jalan Wakaf Stan, Kubang Kerian, 16150 Kota Bharu, Kelantan, Malaysia

*Email: najmi.m@umk.edu.my

Abstract The fabric manufacture change in the direction of the production of high value-added products, Malaysia has the capability to cultivate manufacturing and home fabrics, functional fabrics, and clothing. This paper aims on the development of innovative product by highlighting its benefits over the current sublimation printing machine. These incorporate by developing adaptable roller paper spindle, exterior refill ink tank and the infrared drying system. The impact of these improvements in technology vital is a rapid and useful process, enhance the output of the company, expertise transmission and distributing, reduce working expense and fewer waste of used fabric. At the same time, community socio economic development might be reached instantaneously.

1. Introduction

The production industry is known to be the strength of the country's economic progress, since it can upgrade all sectors from minor to superior machinery needs, accordingly, boosting efficiency. Furthermore, Malaysia is inevitable to the introduction of IR4.0, which has a major impact on the local financial plan and the ecosystem. The IR4.0 businesses need human being assets with fitting capability and knowledge as well as specialized machinery to strengthen their manufacturing chain to fulfill satisfy the market challenge in the future.

Textile products are the nation's 13th largest exporting industry in 2018, accounting for roughly about RM12 billions of Malaysia's overall exports as reported by the Malaysian Investment Development Authority (MIDA) [1]. Malaysia's textile and fabric goods industry is some that is stable, due to a history of fast-paced development as a result of Malaysia's export-oriented industrial evolution in the early 1980s, and currently requires to keep up with IR4.0 by enhancing manufacturing processes in their factory.

2. Inspiration

The clothes and textile business confront high levels of competition from countries in the world. The textile and clothing industry in this country can generate industrial and home textiles, clothing and operational fabrics that change on the production of higher value-added products. This movement is harmonized through the Higher Education Institutions Action Plan 2016-2020 that similarly in line with the 4th Industrial Revolution, which comprises some activities towards entrepreneurial development, that



requires entrepreneurship training as well as the transfer of clothing engineering technology method 'On Job Training and Coaching' [2].

Resources from MIDA exemplify the textile industry became the country's 11th most broad foundation of income in 2017, providing nearly RM15.3 billion (1.6%). The trend is expected to expand in the forthcoming [1]. Concurring to the UN Commodity Trade Statistics archive, China has emerged as the biggest exporter of fast fashion, with 30% of world apparel exports [3]. Former countries are battling over lower manufacture expenses to get their portion of the clothing markets. Malaysian government countered by offering a package to reduce the costs for industrial imports to support manufacturers overcome the recession.

The commercial expansion of selling new products depends on the manufacturer manage with the developments. For example, they came out with thrown away simply the old one style due to the oldness. While the rate of purchase increased by the ways of clothing purchases recycled. There are three main ways that clothing purchases are recycled. First, the clothing may be sold to consumers at a lower price by the primary consumer. Second, it may be exported in bulk for the raw material and lastly, it may be mechanically or chemically recycled into a raw material which can be used for other applications to produce other products.

Eco fashions is intended to be beyond established by manufacturers to compare with the environmental relating and increasing competitive market of fast styles. People are aware of mother earth and try to apply the concept to reduce, reuse and recycle, which can help our world to be improved. Eco-fashions are known as the environmentally friendly accomplishment on its whole life cycle of a product to support sustainability and for ecological measures. Replacement method has been applied by used, such as hemp, bamboo, cotton, kenaf and other fiber crops, which leads to fewer pesticides, and other efforts for natural environment protection [4-7]. The sale of organic cotton fiber grew about 22.7% over the year, shown by the Organic Trade Association 2004 Manufacturer Survey [3].

3. Innovation

The business used sublimation heat transfer technology on fabric, particularly jersey polyester material. The existing printer that recently used is too small and not suitable as the customer requested. Hence, the company needs to order sublimation paper from an oversea supplier from outsources, that lead to higher production cost. The company required an automation technology for sublimation printing size 60" that suitable for the appropriate technology, which can shorten the time and reduce the cost of production.

In this project, a new concept or approach has been introduced through this innovative product by the development of sublimation printing machines to provide a sublimation printing that can be applied by different types of paper, including 80, 100 and 120 grams. Since the existing printer used is too small, it is quite hard for the company to cater the customer's demand. Typically, the standard practices to overcome this problem are by orders from the overseas suppliers. However, the price for the printing and even the postage cost is quite higher. Indeed, the time consumption is wasted and not efficient enough.

Regarding this drawback, the innovation versatile printing machine has several advantages over other printer machines. Figure 1 shows the schematic diagram of the innovative design of the sublimation printing machine. This versatile printing machine can be used on many different types of printer paper regardless no longer depends on the weight and thickness of the paper for example 80 or 100 gram. This machine uses a specially designed roller paper spindle to overcome the problem of paper feeders that are difficult to accept for different types of paper sizes and paper thicknesses.

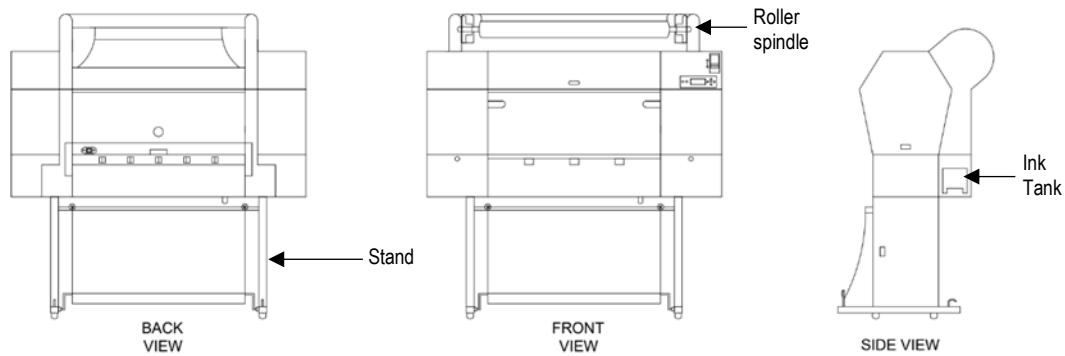

Figure 1. Illustration of the innovative design of the sublimation printing machine

The front of the printing machine had been modified to change the speed of the printing process to maximize the production to the optimum level. Compared to most printers in the market at a slow and even pace. Besides, maintenance tanks are placed outside the mainframe to simplify the printing machine maintenance process and shorten the maintenance time or period.

4. Methodology

The innovative design of sublimation printing manufacturing was divided into three sections as shown in Figure 2. The initial phase began with design the mechanical components of the machine to ensure that the tool designed to execute the work effectively. In this stage, the analyze of structural flexibility of these mechanical systems can be utilized according to the size, shape and weight of the paper. The second stage were procurement and fabrication process. The purchase of equipment such as rollers, motors, head printers, electronic components, and other raw materials. The process of fabricating unique components was custom made.

After accomplishing the installation process, the mechanical part was embedded with the automatic processor micro system to control printer speed as required. The last section of the manufactured were field testing in industry and product commissioning. Indeed, the field tests purposely to update the settings of parameters and components in the printer speed control system to ensure the efficiency of the printer machine runs smoothly. While test acceptance of printing machines the training to staff in the company also being provided.



Figure 2. Flow process of fabrication of sublimation printing machine

5. Output

This product innovation had been recognized at the university level at UMK Research and Innovation Carnival in 2019 by winning a gold medal. Through this recognition, the product has upgraded in terms of Intellectual Property (IP) protection through Copyright (NO. LY2020000599). Furthermore, this innovation design won a silver medal in Malaysia Technology Expo (MTE) 2020 under the manufacturing category. Indeed, the continuous achievement by other/addition of gold medals via the innovative design in Perlis International Engineering Invention & Innovation Exhibition (Pi-Envex) 2020 reveals the potential of this commercialized product. The level of technology readiness for the system is on a scale of 9, indicating that the system successfully commercialized in collaboration with the garment industry, the Azrain Collection and Trading. Compared to existing machines, they are more expensive and less flexible, while the maintenance aspect is more complicated. Indirectly, this innovation of the sublimation printer could help in raising the level of technical knowledge.

The industry is incredibly pleased with the results as they can simplify the process of producing clothes required. In fact, from the statistic of Project Productivity Gain Measurement (PGM) Report via Malaysia Productivity Corporation (MPC), sales percentage is higher more than 50% due to the high rate of production and less time consumption. Besides, the lower operating cost, which is RM5.00 per unit and can reduce wastage by approximately 3% for the raw materials. The speed rate of around 18.5 per hour contributed to the productive process of about 150 pieces per day. Thus, overall sales increased by 33.3% in terms of company productivity. To improve in the future, maybe energy-saving and coating technology can be applied to system sublimation printing [8-11]. This potential is to ensure that the material used can be used for a long time.

6. Conclusion

The industry is incredibly pleased with the results as they can simplify the process of producing clothes required. Thus, the sales percentage is 50% higher from the previous due to easier and time-consuming production. On the other hand, the transfer of fabric cutting technology is also possible with the help of this sublimation mold. Indirectly, this innovation of sublimation printer could help in raising the level of practical knowledge.

References

- [1] Malaysian Investment Development Authority (MIDA) Official Website, “Textiles and Textile Products”2020 <https://www.mida.gov.my/home/textiles-and-textile-products/posts>
- [2] Sani R 2020 in New Straits Times, New Straits Times Press (M) Bhd. A part of Media Prima Group, “Embracing Industry 4.0” <https://www.nst.com.my/education/2018/01/325914/embracing-industry-40>
- [3] Claudio L 2007 *Environ. Health Perspect.* **9** p 28-54
- [4] Rusli H, Abu Bakar M B, Ahmad Thirmizir M Z, Sulaiman M A and Masri M N 2017 *Mater. Sci. Forum* **888** p 193–197
- [5] Roslan R A E, Abu Bakar M B, Mohamed M, Sobri S A, Masri M N, and Mamat S 2019 *Int. J. Adv. Sci.* **28** p 76–81
- [6] Memon A H, Peerzada M H, Muhammad K, Memon S A, Mangi S A, and Mujtaba G 2019 *Int. J. Appl. Sci. Eng.* **9** p 4012 – 4018
- [7] De Fazio D, Boccarusso L and Durante M 2020 *Biotribology* **21** 100113
- [8] Zamri S, Masri M N, Hussin M H, Ismail W and Sulaiman M A 2019 *AIP Conf. Proc.* **2068** p 20053
- [9] Zamri S N A M, Sulaiman M A, Ismail S, Masri M N 2017 *Solid State Phenom.* **264** p 136
- [10] Ismail W, Razab M, Masri M N 2016 *J. Trop. Resour. Sustain. Sci* **4** p 78-81

Acknowledgements

The authors would like to express heart-felt gratuity to Azrain Hamid, owner of Azain Collection and Trading for co-operation during the fabrication process and Universiti Malaysia Kelantan for the grant of UMK Society Impact Research Grant (UMK-SIR).