

Modeling the impact of corporate social responsibility on sustainable purchase intentions: insights into brand trust and brand loyalty

Chunhui Huo, Javaria Hameed, Mo Zhang, Ahmad Fahme Bin Mohd Ali & Nik Alif Amri Nik Hashim

To cite this article: Chunhui Huo, Javaria Hameed, Mo Zhang, Ahmad Fahme Bin Mohd Ali & Nik Alif Amri Nik Hashim (2022) Modeling the impact of corporate social responsibility on sustainable purchase intentions: insights into brand trust and brand loyalty, Economic Research-Ekonomiska Istraživanja, 35:1, 4710-4739, DOI: [10.1080/1331677X.2021.2016465](https://doi.org/10.1080/1331677X.2021.2016465)

To link to this article: <https://doi.org/10.1080/1331677X.2021.2016465>



© 2022 The Author(s). Published by Informa UK Limited, trading as Taylor & Francis Group.



Published online: 07 Jan 2022.



[Submit your article to this journal](#)



Article views: 3595



[View related articles](#)



[View Crossmark data](#)



Citing articles: 4 [View citing articles](#)

Modeling the impact of corporate social responsibility on sustainable purchase intentions: insights into brand trust and brand loyalty

Chunhui Huo^a, Javaria Hameed^a, Mo Zhang^b, Ahmad Fahme Bin Mohd Ali^c and Nik Alif Amri Nik Hashim^c

^aAsia-Australia Business College, Liaoning University, Shenyang, Liaoning, China; ^bSchool of Science, Nanjing University of Posts and Telecommunications, Nanjing, China; ^cFaculty of Hospitality, Tourism and Wellness, Universiti Malaysia Kelantan, Kota Bharu, Kelantan, Malaysia

ABSTRACT

Green innovation performance deals with the strengthening of the organizations for their competence in enhancement of their green image. Current research examines the role of corporate social responsibility (CSR) in improving sustainable purchase intentions. In addition, it explores the mediating roles of brand trust and brand loyalty. It also reveals that how CSR is crucial for green innovation performance in Pakistan. This research uses the structural equation model (SEM) analysis technique to investigate the linkage between constructs in the complex research model. This uses a self-administrated survey-based questionnaire and a convenience sampling technique for data collection. The unit of analysis is buyers from textile and clothing brands consisting 373 respondents. The findings revealed that corporate social responsibility had a beneficial impact on Pakistani purchasers' long-term purchase intentions. Green innovation performance can also be improved by improving CSR. The link between CSR, sustainable buying intentions, and green innovation technology is partially mediated by brand loyalty. Brand trust was identified as a possible link between CSR and brand loyalty. Brand trust and loyalty, interestingly, modulate the link between CSR and sustainable purchase intentions as well as CSR and green innovation performance in a sequential manner. The article's findings will be useful for academics, specialists, and policymakers as these provide glimpse into textile, clothing, and fashion brands with a focus on CSR to improve green innovation performance, as well as highlighting the most relevant studies on the topic and showcasing trends in research and gaps in the field.

ARTICLE HISTORY

Received 20 October 2021
Accepted 4 December 2021

KEYWORDS

Corporate social responsibility; sustainable purchase intentions; green innovation technologies; brand trust; brand love

JEL CODES

M14; M19; N30; M30; M31

CONTACT Mo Zhang  zhangm@njupt.edu.cn

© 2022 The Author(s). Published by Informa UK Limited, trading as Taylor & Francis Group.

This is an Open Access article distributed under the terms of the Creative Commons Attribution License (<http://creativecommons.org/licenses/by/4.0/>), which permits unrestricted use, distribution, and reproduction in any medium, provided the original work is properly cited.

1. Introduction

Corporate social responsibility (CSR) is a corporate strategy tool that allows for differentiation and competitive advantage by combining academic and commercial goals (Shafique et al., 2021). Corporate social responsibility (CSR) is an area of management that frequently enables extremely competitive differentiation by combining market as well as societal goals (Ali & Kaur, 2021). And because of its dual benefits, CSR is a business strategy platform for marketing. Initially, it aids in creating a competitive edge by focusing on noneconomic aspects. CSR is a business priority that aids in the development of positive attitudes among consumers and brand. It is well understood that brand image is an important component of the marketing strategic approach, and when done correctly, it can lead to increased customer loyalty, increasing concentrations of purchasing intention, as well as enhanced corporate success (Kataria et al., 2021).

Currently, corporations and governments see corporate social responsibility (CSR) as the key solution to societal problems. The importance of corporate social responsibility and the contribution of businesses to society cannot be overstated. CSR, on the other hand, is critical not just for solving global challenges but also for enhancing company success. Companies have long been aware of CSR, which is the most important standard business practice that they must follow if they want to thrive in today's chaotic and competitive marketplace (Foroudi, 2019). According to Kim and Lee (2019), CSR may be a successful promotional technique that improves business image and consumer behaviour from a marketing standpoint. Furthermore, CSR's advantages go beyond sales. CSR programmes have a significant influence on consumer and stakeholder expectations, resulting in higher business performance.

In this frame of reference, it has been suggested that functional and irrational factors can coexist to create a mechanism that can explain consumers' attitudes towards CSR. To date, there is almost no research that examines the role of conscious and subconscious variables in this domain. Throughout the last decade, scholars and practitioners alike have viewed corporate social responsibility (CSR) as a strategy implementation and brand management tool (Ali & Kaur, 2021). Decision-makers advocate for the contribution of sustainable business practices in helping to improve the company's reputation in the marketplace (Khan et al., 2021).

Furthermore, advances in digital technology have improved connectivity, allowing customers to receive quicker and more effective information on issues such as global warming, depletion of natural resources, firm improper conduct, or business scams, prompting consumers to incorporate the firm's as well as brand's CSR reputation into their decision-making procedure (Shafique et al., 2021). Industrialists, environmental authorities, educators, and entrepreneurs did not pay enough attention to the ecosystem because they thought that commodities made in their companies had little impact on the environment. The depletion of natural resources has become a global issue (Hristov et al., 2021). As a result of various environmental protection measures that have been reported, enterprises must focus on the environment as well as natural environmental protection tasks.

Companies are attempting to establish long-term relationships with customers in order to ensure their long-term success. The environmental effects of human behavior

are increasing worldwide concern for individuals, policy experts, countries, and organizations. In recent years, governments have implemented corrective policies to mitigate or mitigate these environmental degradations (Asiaei et al., 2021). Brand names are expected to send diverse techniques to customers that aid in product involvement and alleviate the discomfort associated with purchase decision-making (Islam et al., 2021). Creating, trying to maintain, as well as adapting high brand equity, on the other hand, is difficult, time-consuming, and expensive. Earlier brand marketing research has emphasized that strong companies share information as consistent understanding, differentiate corporation offerings, as well as deliver on their promises. Environmental sustainability, as well as green practices have a close relationship with firm innovation. Organizations that are early adopters of green innovation strategies may gain and sustain a competitive advantage. Consequently, effective green innovation performance (GIP) assists firms in increasing efficiency as well as establishing and strengthening core competencies.

To define loyalty, we must first distinguish between repeat purchasing behavior regarding sustainable purchase intention and customer loyalty. Repeat purchasing behavior, in our opinion, is the actual repurchase of a brand. Rebuying behavior is important regardless of the consumer's level of commitment to the brand or the brand trust (Zhou et al., 2021). Brand loyalty, on the other hand, considers not only the behavior of rebuying but also the antecedents of that behavior. For beginners, most of them failed to distinguish between both repeat purchasing behavior as well as true brand recognition on one hand, and baseless as well as true brand loyalty on the other.

CSR research has taken many different approaches throughout the years, but no comprehensive conclusions have emerged. CSR is concerned with interactions between organizations, industries, cultures, and countries, according to one interpretation. As a result, the current study looks on the impact of CSR in the textile, fashion, and garment industries. Previously a gap was prevailing in the research area of impact of CSR on sustainable purchase intention of social virtues and green innovation performance of the environmental virtues. To bridge the gap, this research was designed and conducted. Different variables which could modulate the sustainability in purchasing intention and green innovation performance such as brand trust and brand loyalty were included in the framework.

Although there have been several empirical research on the impact of perceived CSR on consumer purchasing behaviour, there have been few empirical studies on the impact of CSR attributions or CSR motives on consumer purchasing behaviour. Furthermore, the conceptual models evaluated in these research studies were rather straightforward; in general, these studies experimentally tested the influence of CSR incentives on attitudes about the business and/or purchase intention (Wongpitch et al., 2016). Given the critical role that CSR may play in cultivating brand loyalty, there are few studies that have looked at the link between CSR and brand loyalty in higher education. Another source of worry is that CSR has mostly been studied in the Western setting, with little study conducted from a non-Western perspective (Cambra-Fierro et al., 2020).

Paying enough attention to 'eco-friendly' issues seems to have been a major motivator for industrial academics and practitioners in recent decades. Due to the obvious

competitive atmosphere, the business scenario has changed rapidly throughout the world (Zittis et al., 2021). That's not enough to generate a profit and achieve a competitive edge; it is also absolutely essential to be accountable for environmental consequences (Duque-Grisales & Aguilera-Caracuel, 2021). Therefore, the current study focuses on which predictors investigate environmental and social performance. Manufacturing industries have a high environmental impact, as well as the industry is a significant contributing factor to issues such as global warming, waste, depletion of natural resources, water pollution, as well as air pollution (Mukherjee & Chandra, 2021). Today's corporate environment is characterized by a high level of launched programs, the company's marketing clutter, as well as consumer buying enchantment.

There have been several implications of corporate social responsibility studied in past. A very little had been focusing the impact of CSR on green innovation performance. On the other hand, changing climate demands the practical measures for correcting the climate and worsening effects of the global warming. It was necessary to develop a model for checking the impact of CSR on previously discussed aspect. In this regard, this study was designed which mainly deals with corporate social responsibilities, sustainable purchase intentions and green innovation performance with the following objectives.

- To analyze the impact of corporate social responsibilities on various factors such as brand trust, brand loyalty, sustainable purchase intention and green innovation performance.
- To evaluate the impact of brand loyalty on sustainable purchase intention and green innovation performance.
- To estimate the impact of brand trust on sustainable purchase intention and green innovation performance.
- To evaluate the mediating roles of brand trust and brand loyalty.

2. Review of literature and hypotheses development

2.1. Impact of CSR on sustainable purchase intentions

For a long time, the garment sector has been a vibrant, yet sustainable, industry. The focus of this research was to use the stimulus-organism-response paradigm to investigate the techniques used by fast fashion shops to position sustainability (Dhir et al., 2021). In past, a study looked into how assessed corporate social responsibility (CSR) effort, pricing value, including brand equity were influenced by sustainability positioning tactics (Aghaei et al., 2021). Controlling expenses during the manufacturing process and supplying lower-cost items to consumers are two essential components in the apparel industry's success (Javaid et al., 2021). In this regard, most fast-fashion retailers succeed. They also sell stylish clothing. Fashion industry refers to the low-cost but stylish trends in the apparel industry (Brydges, 2021).

They must, however, ameliorate the negative consequences of reduced prices, such as consumer impressions of poor development and lack of sustainability, considering consumers frequently assume fashion products from these types of merchants to be irresponsible and of inferior quality. Sustainable consumption has evolved from a

fringe movement to a mainstream one in American culture (Franco, 2020). Researchers have attempted to comprehend this social shift by examining the influence of numerous factors on consumers' corporate sustainability, such as environmental awareness and attitudes (Matharu et al., 2020). Consumers are increasingly concerned than it has ever been about environmental and ecological issues (Rhein & Schmid, 2020). Furthermore, there seems to be little research into fashion garment consumption about apparel and materials market sustainable development. The purpose of this research was to look into the impact of the fast-fashion brand's sustainability efforts, as well as how consumers understand these efforts (Neumann et al., 2021). Previously, a study looked into the relationship between various sustainability positioning techniques and the influences of brand CSR effort, perceived financial cost, and product attributes (Achabou, 2020).

The influence of CSR efforts, pricing value, and brand equity on consumer purchasing intentions. Several research studies in past have been carried out to check the impact of CSR on consumers's purchase intentions in different perspectives. For example, in a research conducted by Qasim et al. (2017), the impact of CSR on the purchase intention of consumers was explored. The mediating impact of business reputation and the moderating role of peer pressure were also investigated in the relationship between corporate social responsibility and consumer purchase intention. The findings showed that business reputation had a favorable relationship with consumer purchase intent and that corporate reputation completely mediated the beneficial impact of corporate social responsibility on consumer buy intention. Peer pressure also moderated the association between business reputation and customer purchase intention. It proved a strong relationship between CSR and the purchase intention. Another study on the effects of CSR on purchase intention was conducted by Ali and Sohail (2018). Five elements were used to assess corporate social responsibility. The study's findings revealed that elements of CSR had a considerable influence on customers' buying intentions. Based on the proposed and impactful role of CSR on sustainable purchase intentions, the following was hypothesized in our study.

H1: CSR has a positive impact on sustainable purchase intentions.

2.2. Impact of CSR on green innovation performance

Green innovation is the technology that is used to reduce waste, global climate change, water consumption, air pollution, charcoal, oil, and power use, and energy conservation (Zou et al., 2021). Sustainability strategies are used by companies to achieve advantages in terms of environmental issues over companies that do not (Hristov et al., 2021). Furthermore, experts asserted that there is a controversy about whether a firm's effectiveness should be assessed by organizational resources or strategies (Hooi et al., 2021). Investigators recently discovered that marketing strategy is an important predictor of environmental preservation and corporate operations (Al-Swidi & Saleh, 2021). Furthermore, research has shown that proactive environmental initiatives boost financial performance. Considering this, natural RBV theory placed a greater emphasis on an environmental management system for assessing long-term success (Abrams et al., 2021).

CSR impacts environmental management systems, and green innovation leads to improved performance measurement, according to the link among CSR, environmental strategic plan, and green innovation (Song & Yu, 2018). CSR has been proven to boost organizational performance in the literature (Lu et al., 2020). Shrivastava and Hart (1995) proposed that environmental management system and green process innovation explain the association between these two profitability and capabilities advantage, associated with the natural RBV theory (Xie et al., 2019). As a result, green technology and ecological strategy are employed as a moderating mechanism among CSR with environmental performance (Shafique et al., 2021).

Organizations that are early adopters of green innovation techniques may be able to achieve and maintain a competitive edge (El-Kassar & Singh, 2019). Effective green innovation performance (GIP) assists businesses in increasing efficiency, establishing and strengthening core capabilities, and enhancing their green image (Sharma & Choubey, 2021). As a result, all of these efforts may enable and support businesses to achieve improved performance and profitability. Organizations must explore any measure aimed at increasing the GIP and strengthening the sustainability performance of such sectors (Makhloufi et al., 2021). However, there has been a little empirical study on how diverse capacities, as determinants, affect GIP progress (Babatunde et al., 2022).

Despite the fact that many studies have looked into the influence of various corporate social responsibility (CSR) activities on environmental sustainability, few have looked into the implications of CSR activities on green innovation performance. Green innovation performance, however, has received little attention as a predictor of environmental initiatives. In connection to impact of CSR on green innovation performance few research studies have been conducted in past such as Shahzad et al. (2020) and Hong et al. (2020). According to the findings of t one of these studies, all aspects of CSR were determined to be favorably relevant in promoting environmentally sustainable growth. Furthermore, ecologically friendly development improves the performance of green innovation. Because all CSR dimensions demonstrated favourable relationships with environmentally sustainable development, the research findings recommended that CSR activities should be included in organizational environmental policies for green innovation performance. Based upon the strong link between the two variables, the purpose of this research was to see how different CSR aspects affect ecologically sustainable development and, in turn, green innovation performance with a proposed hypothesis as follows.

H2: CSR has a positive impact on green innovation performance.

2.3. Impact of CSR on brand trust

In a healthy relationship, trust seen between two sides is crucial. Consumers' perceptions of being able to rely on a firm are referred to as trust, and a lack of trust leads to hesitations in engaging in business transactions (Nyamrunda & Freeman, 2021). In terms of the impact of trust on commercial transactions, the trust construct was used as a key component in predicting consumers' expectations and perceptions (Ben Amor & Ben Yahia, 2021). Consumers' willingness to put their faith in a brand to deliver on its promises is referred to as brand trust. Whenever one party has faith in the quality and reliability of an exchange relationship, trust occurs (Raza-Ullah, 2021).

Customers that seem to have a significant impact on brand trust are more likely to predict a satisfying outcome (Le et al., 2021). In the international market, brands are under a lot of pressure to transmit a coherent brand image to their clients. As a result, a brand's established history should be viewed as a valuable resource that gives the company a competitive edge in the industry (Cho et al., 2021). Promotion is an important aspect of any marketing plan, and when done well, it can lead to increased customer satisfaction, better buy intentions, and increased corporate success (Othman et al., 2021). Customers are most likely to receive various signals from brands that aid in product involvement and alleviate the discomfort associated with buying decisions (Byun et al., 2021).

Creating, sustaining, as well as adapting high brand equity, on the other hand, is difficult, takes a very long time, often costs a lot of money (van Boerdonk et al., 2021). Strong brands, according to prior branding studies, establish a clear and concise message, distinguish corporate offers, and fulfill on promises made (Batt et al., 2021). By tying a brand to the past without producing the sense of an obsolete company, brand history is thought to support the image stability essential to building audience brand trust (Guan et al., 2021). Trust is essential for developing cooperation, and research shows that trust leads to increased loyalty (Nelson & Kim, 2021). Because it generates a continual process for the maintenance as well as the development of the relationship, trustworthiness is the most significant antecedent of brand loyalty. As a result, the importance of trust in regulating loyalty and boosting consumer commitment is supported by research. Trust, loyalty, plus commitment can all benefit from a consistent brand identity (e.g., brand legacy).

There are few works done in the past to analyze the role of CSR towards developing the brand trust and has a lot of scope to be analyzed in its direct relation. A study tried to find out the impact of CSR on brand trust in different perspective but that could lead to the development of a hypothesis given below. It's very important to look at the link between CSR and brand trust. The study by Barnes (2011) revealed that two components, legal and employee, and ethics and economics, comprised CSR. Because these elements constitute CSR, they point to many areas that both represent CSR and influence brand trust. The overall goal of this study was to look at the relationship between CSR and brand trust. This study laid the groundwork for future research and identified many key implications for business executives to consider in terms of CSR spending and the impact on their portfolio of brands. In the case of the socially responsible firm, the variance in brand trust described by CSR was larger than the variance explained by the less socially responsible company. Based on the inference from the possible linkage between the said variables, the greater the percentage influence of CSR on brand trust, the more socially responsible the firm is. So, to test the scope of the claim following hypothesis was developed and tested.

H3: CSR has a positive impact on brand trust.

2.4. Impact of brand trust on brand loyalty

Since brand loyalty, brand image, as well as brand trust are becoming increasingly crucial in marketing, they are often studied in the marketing literature (Zeren &

Kara, 2020). Firms profit from brand loyalty in various ways, including an increase in market share including gain more customers, support for brand extensions, lower marketing expenditures, and brand defense against competitive threats (Suhud, 2021). A larger client base is a barrier to entrance, a foundation for a premium price, an opportunity to respond to competitor developments, and a bulwark over price competition that is harmful (Madhavaram, 2021).

Considering trust as a vital component of any successful strong relationship, creating and maintaining confidence at the heart of the brand image (Alam et al., 2021). The fundamental problem in brand loyalty research is identifying and measuring the brand recognition construct. Since this dimension is made up of two separate aspects: behavioral and attitudinal, scientists have struggled to define and evaluate brand loyalty (Hwang et al., 2021). The establishment of brand loyalty is explained by both elements. From just one side, the psychological component shows that loyalty is formed as a result of a qualitative assessment or connection between both the brand and the consumer, and so this attitude is formed as a result of the particular brand matching the consumer's interests (Hong et al., 2021).

Loyalty creation, on the other side, is described by the consumer's previous purchases, ultimately result in a specific buying habit (Ameen et al., 2022). 'A relatively permanent change to re-buy or patronize a favored manufacturer continuously in the long term, resulting in repeated relatively similar or even the same set making purchases despite environmental factors and marketing initiatives having the greatest potential to influence', according to the definition of brand loyalty (Rizomyliotis et al., 2021). 'A condition that represents how likely the consumer will be to move to another brand, particularly when that trademark makes a nice change, either in pricing or in features of the product', according to the definition of brand loyalty (Klein & Sharma, 2022). A brand trust provides various major strategic benefits for businesses, including being viewed as important (Lentz et al., 2021). In contrast, looks at brand loyalty via the lens of 'brand awareness', which relates to the structure of the client relationship as well as the degree to which consumers perceive 'in sync' with the product (Zhao et al., 2021). Customers that have significant brand trust are extremely committed to the product and start seeking ways of interacting with something and express their opinions with others.

Several research studies in the past have been conducted to check the impact or role of brand trust in developing the brand loyalty such as Kwan Soo Shin et al. (2019). The study's findings showed that brand trust and commitment have a favorable and significant impact on brand loyalty. Another study by Bozbay and Karakuş Başlar (2020) found the role of brand trust on brand loyalty. According to the findings, brand trust has a strong influence on brand loyalty, while brand affect acts as a mediating factor in the link across brand trust and brand loyalty. So, to explore the potential of brand trust impacts on brand loyalty in reference to our research following hypothesis was developed.

H4: Brand trust has a positive impact on brand loyalty.

2.5. Impact of CSR on brand loyalty

To attain lifelong customer value, the key premise of the marketing concept is to develop customer loyalty by fulfilling their requirements (Vinerean & Opreana, 2021).

Customers that prefer and acquire a company's services over and over are said to have 'lifetime customer value (Boudreaux et al., 2021)'. As previously said, trust is a prerequisite for establishing and keeping consumer connections. According to the literature, brand trust focuses on brand loyalty, and commitment generates an ongoing challenge for continuing and maintaining partnerships (Le et al., 2021). Customers recognize less risk in future orders of a brand when they gain trust in it (Melović et al., 2021). As a result, they are loyal. As a result, loyalty can be defined as 'a belief commitment to repurchase or re-patronize a promote new products or service will be produced, despite situational factors and marketing efforts that may promote switch behavior our (Wang et al., 2021)'.

Loyalty in terms of how he or she is expected to perform in the future (Ahmad et al., 2021). 'A biased (i.e., nonrandom) attitude (i.e., purchase) demonstrated over moment by some decision-making product with respect between one or even more available brands out from under a set of this kind of brands and also as a function of psychological (judgement, interpretative) processes', according to the definition of brand commitment (Muthu Lakshmi & Suresh, 2021). Loyalty in perspective of how he or she is expected to perform in the future. The Commitment-Trust Theory describes the connections between constructs of this study, company heritage, brand trust, brand recognition, and airline service repurchase intention (Loh & Hassan, 2021). Trust is a significant mediating component for relationship commitment, according to Morgan and Hunt's approach. They think that trust influences relationship commitment for numerous reasons, based on research evidence from the strategic management literature (Muthu Lakshmi & Suresh, 2021).

Additionally, several empirical studies have demonstrated that CSR has a beneficial impact on customers' inclinations to purchase the brand again in the future and has a positive impact on brand loyalty. CSR's societal advantages have been thoroughly demonstrated to a large extent. However, there is virtually little evidence available about the benefits to the businesses who use it. In a research conducted by Dapi and Phiri (2015), consumer opinions about various CSR initiatives, as well as the influence of CSR on brand image and brand loyalty, were the main goals of the study for research. The study's primary results were that, while most customers were unaware of what CSR is, they believed corporations were expected to be socially responsible. Most significantly, it was discovered that knowing about a company's CSR actions might improve its corporate image and brand loyalty. Another research conducted on the mentioned impact got similar results by Rivera et al. (2019). This research showed that CSR initiatives had a direct, positive impact on loyalty, as well as an indirect impact through their beneficial impact on brand recognition and consumer satisfaction. Depending on the available literature a hypothesis was formulated as follows.

H5: CSR has a positive impact on brand loyalty

2.6. Impact of brand loyalty on sustainable purchase intention

Several studies have expanded the idea of brand loyalty to include multiple traits outside of behavioral features, and customers can be considered brand loyalty individuals if they exhibit a choice for a certain brand beyond repeat purchasing behavior

(Ibrahim & Aljarah, 2021). This brand loyalty is evident in high-involvement products and reasonably simple judgment, and it differs from repurchasing in that customers evaluate psychological attitudes in addition to their devotion to a certain brand (Kataria et al., 2021). The level of commitment to a specific brand is defined by brand loyalty, which is a fundamental term in marketing. Customers that have a (Kursan Milaković, 2021) positive attitude about a brand are willing to pay higher prices and also have plans to spread the word about certain branded products (Safeer et al., 2021).

Brand loyalty, for example, is characterized by positive preferences and attitudes for a specific product. A brand loyalty is a psychological and emotional tie to a specific brand that demonstrates an express desire to maintain a long-term engagement with just that brand (Willis, 2021). Brand loyalty reduces sales turnover and helps businesses remain profitable (Zhou et al., 2021). In other aspects, loyal customers are profoundly committed to repurchase and continue using their preferred items and services in the future, notwithstanding situational consequences and marketing activity connected to provoking switching behavior (Hall et al., 2021). Customers who are loyal to a business perceive to it more favorably than non-loyal or transferring customers, enabling them to hesitate to switch (Wu et al., 2021). Product or service in relation to a consumer's likelihood of purchasing products or services, as well as changes in consumption behavior that occur during this process (Kursan Milaković, 2021).

It represents the customer's expected or possible upcoming action, and belief, mindset, and perceived price are all closely connected with the conversion to actual purchasing products. A good consumer valued attitude forward towards a product enhances the chances of consumption, resulting in increased product quantity and frequency (Cantillo et al., 2021). Many studies have been conducted on the interpreted values as well as purchase intentions from various points of view, and the majority of them assume that value perceptions can strongly impact on purchase intentions. In a study conducted in reference to the cosmetics industry direct impact of brand loyalty on intention of purchasing by Hameed and Kanwal (2018). The findings of this study revealed that brand loyalty has a positive significant influence on purchase intention, as well as a positive significant association between buy intention and cosmetics brand loyalty. Not a lot of research has been conducted on the said concept in past but there was a scope of finding the relation between the two. So, keeping in mind the impact of brand loyalty, following hypothesis was formulated.

H6: Brand loyalty has a positive impact on sustainable purchase intentions

2.7. Impact of brand loyalty on green innovation performance

According to the firm's natural-resource-based theory, companies increasingly seek to improve and harmonize their relationship with the external natural environment (Asiaei et al., 2021). They can accomplish this by continuing to pursue three distinct yet interconnected environmental management practices: pollution reduction, extended producer responsibility, and environmental sustainability (Xu et al., 2021). Green innovation has a positive impact on a company's overall performance. Because

of GI, new processes and systems have the potential to completely transform existing ways of operating, reducing overall their harmful effect on the environment (Bianchi et al., 2021). Furthermore, investigative GI may lead to the development of novel products and procedures that might aid in the cleaning, repairing, and recovery of the ecosystem (Taylor & Lovell, 2021).

According to research, a company's environmental policy, as well as specific proactive measures aimed at generating eco-friendly technologies, can boost investment performance. But from the other side, an ineffective management culture may cause environmental management to be reactive rather than proactive, thus raising the risk of tragedy and damage reputation (Chandrasekar et al., 2021). Pollution avoidance, product stewardship, and sustainable development are major environmental measures that bring enterprises to product differentiation, according to the natural resource-based paradigm (Schmidt et al., 2021). Furthermore, brand loyalty contributes to better brand outcomes such as positive word-of-mouth marketing, acceptability of the premium pricing, and a higher likelihood of repurchase (Ltifi & Hichri, 2021).

In the case of sustainable marketing, in order to achieve a competitive advantage, ever more companies are making significant efforts to meet consumers' environmental pressures by implementing green supply chain management. Green positional awareness raises consumer green awareness, which affects green purchasing intentions (Mukherjee & Chandra, 2021). The overall appearance is a good predictor of attitudes against green behaviors, and it also has a significant influence on several behavioral intentions, which would include purchasing behavior and desire to pay a higher price. Despite earlier knowledge about green branding that focuses on customer confidence, satisfaction, as well as brand loyalty, studies have investigated the relationship among green image but also brand loyalty is scarce. Quite handsome amount of research has been carried out in the analysis of checking the impact of green innovation on brands and their relationships with the customers where the focus had not been towards the brand loyalty specifically but our research suggests that there is a possible relation between green innovation performance and the brand loyalty so, to analyze the proposed impact a hypothesis was developed in this regard.

H7: Brand loyalty has a positive impact on green innovation performance

2.8. Mediating role of brand trust between CSR and brand loyalty

Throughout the last decade, scholars and practitioners alike have viewed corporate social responsibility (CSR) as an effective strategic brand management solution. When comparing comparable models, people preferred brands that seem to be socially conscious and request more than a convenient and economical at a low price. CSR activities help to develop positive attitudes among clients and create brand reputation (Islam et al., 2021). Even through an awareness of the significance of CSR initiatives in the consumer purchase decision, there are unanswered questions about the contribution of corporate social responsibility activities in branding practices (Ali & Kaur, 2021).

There is agreement on the significant impact of corporate social responsibility and brand recognition (Mukherjee & Chandra, 2021). For starters, there is a complete

misunderstanding about the impact of CSR on brand recognition. The immediate relationship between corporate social responsibility and brand loyalty remains a contentious issue. CSR practices have a significant impact on brand loyalty, whereas research discovered no significant impact of consumers' perceptions of social responsibility on their commitment to an organization.

A few works have been conducted in past to check the mediating role of brand trust between different variables. For example, the mediating role of brand trust was analyzed between brand satisfaction and the purchase intentions. The study was conducted by Cuong (2020). Brand satisfaction had a favorable influence on brand trust and purchase intention, according to the findings of the study. Brand trust has a beneficial impact on purchase intent, according to the research. In addition, the findings revealed that brand trust acted as a mediator in the link between brand satisfaction and purchase intention. Another similar research conducted by Villagra et al. (2021) got the similar mediating role of brand trust and the findings showed that brand personality has an indirect beneficial impact on consumer loyalty, which is mediated through brand trust. So, keeping in view the mediating role of brand trust among various variables across the research studies, following was hypothesized.

H8: Brand trust mediates the relationship between CSR and brand loyalty.

2.9. Mediating role of brand loyalty

Depending on the customer perceptions, the impact of corporate social responsibility (CSR) operations on brand image, customer loyalty, brand loyalty, as well as brand preference. In this particular respect, the emergence of social media is a game-changer in the context of relationship marketing because its audience and make with a corporate strategy touch point to engage customers with a product (González-Rodríguez et al., 2021). Prior literature has empirically ignored the connection between a brand's corporate social responsibility (CSR) practices as well as customer satisfaction perspectives (Achabou, 2020). The idea of sustainability was initially articulated and addressed in Stockholm in 1972 at a conference named 'The Human Environment'. Sustainable consumption has just been defined as the use of products and services which meet needs and wants while limiting natural resource waste and avoiding harmful ingredients, resulting in a higher quality of life for consumers (Tekinbaş Özkaya et al., 2021). Sustainable procurement has been characterized as a primary form of consumer behavior that corresponds to transactions that are influenced by environmental and societal considerations.

The purpose of this research was to discover the relationship between organizational values and brand trust and loyalty, as well as the mediating role of corporate social responsibility (CSR) and UNESCO Sustainable Development Goals (SDGs) like green products. The stakeholder theory (Freeman, 1984) emphasizes the numerous persons, groups, and organizations that influence and are influenced by a phenomenon's long-term viability (Bass & Grøgaard, 2021). This has been used to describe a wide range of commercial and societal activities. There are a number of ramifications for society and company operations (Duque-Grisales & Aguilera-Caracuel, 2021). The GI of a company is linked to its overall success.

It can be used by businesses to boost productivity and offset growing raw material costs. Experimental GI focuses on integrating new products and processes while exploiting GI helps to enhance but not drastically modifying the existing goods and processes to make them more environmentally sustainable (Song & Yu, 2018). New goods and processes based on GI have the potential to completely revolutionize established business models, dramatically lowering their negative environmental impact (El-Kassar & Singh, 2019). Furthermore, exploratory GI may lead to the development of new products and procedures that can aid in environmental purification, healing, and restoration. A few research in the past has reported the mediating role of brand loyalty towards many variables and this research utilized the same concept of checking the mediating role of brand loyalty on suggested variables of this research, For example, Tunjung Sari et al. (2020) examined the mediating role of brand loyalty between repurchase intentions and high tech products in Indonesia. All hypotheses of the research were validated by the data, brand image has a significant and positive impact on repurchase intention, and brand loyalty mediated the influence of brand image on repurchase intention. There are not much literature studies available on the argument of using brand loyalty as a mediator between the variables but this provides the gap for further research in this regard so, the following hypotheses were developed and tested.

H9: Brand loyalty mediates the association between CSR and sustainable purchase intentions.

H10: Brand loyalty mediates the association between CSR and green innovation performance.

2.10. Role of serial mediation of brand trust and brand loyalty

Brand loyalty is defined as a sentimental connection to a company's products and services. Furthermore, brand loyalty is defined as 'a firmly held commitment to continuously re-purchase or re-patronize preferred products/services in the future'. It is conceptualized differently by different measures: behavioral and attitudinal (e.g., Behavioral loyalty, according to marketing research, is a repurchase procedure that promotes and builds client loyalty to a specific service provider (Willis, 2021). Attitudinal loyalty differs from behavioral loyalty in that it is defined by the customer's psychological and emotional conditions, which then regulate stimuli and response, as opposed to behavioral loyalty, which is defined by repurchasing (Liu et al., 2021). In the link among Brand trust and positive relationship between perceived, the consecutive mediating variables of customer loyalty and brand trust.

Through the mediation impact of brand awareness and brand loyalty, SMMA hopes to impact repurchase intentions (Yan et al., 2021). As a result, if the association between both the study individual and completely reliant constructs was complicated, a change in one mediator could bring about a change in another, necessitating a deeper look through into sequential mediation relationship issues as a better way of understanding possible connections among all variables. The efficiency of sustainable competitive strategy has been widely examined as sustainability is becoming an essential factor for businesses (Mathiyazhagan et al., 2021). Although it is well recognized

that a firm's brand image can always be shaped by shop or product attributes (e.g., store design as well as a line of products), the company's long-term viability also has a substantial impact on the brand perception (Kursan Milaković, 2021). In the fashion industry, sustainability is being used in a variety of ways (UDSAI, 2009). It makes reference to a company's social, ecological, and economic implications.

These three components are frequently discussed in order to guide a company's success. Furthermore, sustainability can be explained on the basis of ethical business practices (Mukherjee & Chandra, 2021). These practices have the potential to have an impact on workers, buyers, the environment, and subsequent generations. As a result, companies must consider sustainability including both short-range and long achievement. With the activation of green innovation effectiveness, the awareness of sustainable development, as well as the benefits of industries, is increasing over time (GIP). Working to improve a firm's GIP, particularly in manufacturing sectors, can hasten sustainable growth and help alleviate global environmental concerns (Adelodun et al., 2021). To start investigating Green innovation performance from its predictor variables, we use social network theory, as well as contingency theory to demarcate the relationship among networkability, dynamic capabilities, environmental fluid flow, and GIP (Duque-Grisales & Aguilera-Caracuel, 2021). Green innovation aims to make existing production processes more ecologically sustainable by enhancing them.

Utilizing greener raw resources, minimizing waste, creating products utilizing eco-design principles, lowering carbon emissions and imprints, and limiting water, power, and other raw material uses are all examples of ways to reduce carbon dioxide emissions as well as footprints (Asiaei et al., 2021). According to previous research, GIC is significantly and positively correlated to all aspects of long-term achievement, including economic, interpersonal, and natural environments (Willis, 2021). Not all elements of long-term performance are inextricably linked to GIC. For instance, social performance, which is defined as 'improvement of interested parties welfare, society health & security, occupational health and safety, and disaster preparedness on the common person', has a significant association with GIC than performance measurement (Klößner et al., 2021). GIC's reduced impact on environmental issues refers to less environmental degradation and protection from exploitation of resources. A lot of serial mediation models have been tested in past about the variables used in this study but no study has been found specifically analyzing the serial mediation role of brand trust and the brand loyalty. Literature is available on the mediating links of brand trust and the brand loyalty between several variables but serial mediation has a potential scope of analysis for the brand trust and the brand loyalty so we utilized the research gap and developed the following hypotheses to test the serial mediation role of brand trust and brand loyalty between the utilized variables in our framework.

H11: There exists a serial mediation of brand trust and brand loyalty between CSR and sustainable purchase intentions.

H12: There exists a serial mediation of brand trust and brand loyalty between CSR and green innovation performance.

Our research is based on the conceptual framework as presented below (Figure 1).

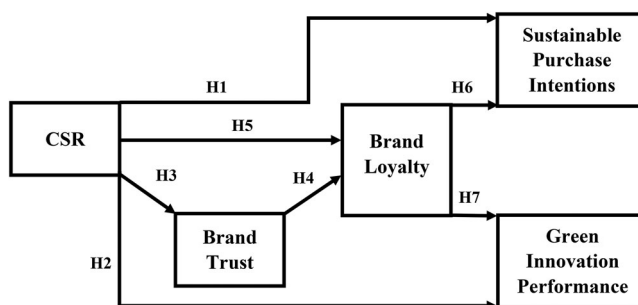

Figure 1. Conceptual framework.

3. Research methodology

3.1. Study design

Current research is based on positivism as a philosophy. In terms of temporal span, this study is quantitative and cross-sectional. The study was conducted in the Pakistan fashion and textile industry. The unit of analysis is clothing and textile customers. Particularly, Textile customers who visit branded outlets of clothing brands or purchase clothing products from any other retailer are included in the study's target group.

3.2. Measurement scales

The measurement scales of all constructs in the framework have been adapted from previously developed scales. In addition, all measurements are modified slightly but it did not change the overall meaning. In total, 24 items were considered for all constructs. The corporate social responsibility (CSR) construct was measured through a five-item scale (Akbari et al., 2021). Brand trust (BT) was measured through three items from (Zeren & Kara, 2020) and five items for brand loyalty (BL) from (Kazmi & Rahman, 2021). Green innovation performance has five-items scale (Albort-Morant et al., 2016; Song et al., 2021). Sustainable purchase intentions (SPI) were measured through six items scale (Kazmi & Rahman, 2021). Measurements for all constructs are based on 5 points Likert scale from strongly agree (5) to strongly disagree (1).

3.3. Data collection process

This study used a survey method in data collection. Data were collected via a self-administered questionnaire. Data is frequently collected via mailed or faxed questionnaires and the internet for self-administered questionnaires. The questionnaire was designed on Google-Forms online. Convenience sampling was used to gather data in this study; convenience sampling is the most appropriate sample strategy when the population is specified, and data collection is challenging. The Google forms link was forwarded to people via email and social media channels (Facebook and WhatsApp). There was a total of 489 links sent out to respondents, however, only 403 customers completed the survey. Finally, 373 responses were deemed dependable enough to be

used in the data analysis. The file was saved as a CSV file from Google Forms. The file was then encoded into Smart PLS 3.3.3 for a two-stage structural model measurement assessment.

3.4. Analysis technique

The study employs a partial least square structural equation model (PLS-SEM) (Hair et al., 2017). PLS-SEM is a two-stage estimation procedure that includes both a measurement model and a structural model evaluation (Sarstedt et al., 2017). The goal of the measurement model is to evaluate the constructs' and indicators' reliability and validity (discriminant and convergent validity). Constructs association is calculated using Cronbach alpha (α) and construct reliability (CR). In addition, factor loadings (FD) were calculated to assess indicator consistency within a construct. Estimating the distinct features of the variables from other variables in the model is what discriminant validity is all about (Hair et al., 2017). The discriminant validity is measured using three methods: cross-loadings, the Fornell and Larcker ratio, and the HTMT ratio. All are association metrics that capture concept homogeneity and multicollinearity (Hair et al., 2011). Hypotheses are assessed in the second stage and the process is called structural model assessment (Hair et al., 2017). In hypothesis testing, respective p -values, t -statistics, R^2 , f^2 , and Q^2 are considered to accept or reject the proposed hypotheses.

4. Data analysis and results

4.1. Demographic summary of respondents

The demographic details are featured in Table 1. The total sample size was 373 clothing and textile buyers. Among them, 47.18% were male and 54.82% female. They

Table 1. Demographic summary.

Demographics	No	%
Gender		
Male	176	47.18%
Female	197	52.82%
Age		
18–22 years	61	16.35%
23–27 years	45	12.06%
28–32 years	63	16.89%
33–37 years	57	15.28%
38–42 years	59	15.82%
43–47 years	43	11.53%
48 years and above	45	12.06%
Do you often buy clothing items?		
Yes	361	96.78%
No	12	3.22%
Do you prefer buying?		
Online	276	73.99%
Offline (Traditional shopping)	97	26.01%
CSR spreads positivity in public about the brand		
Yes	299	80.16%
No	174	46.65%
Does CSR enhance green innovation performance?		
Yes	210	56.30%
No	163	43.70%
	<i>N</i> = 373	100%

Source: Authors collection.

belong to seven age classes as 18–22 years (16.35%), 23–27 years (12.06%), 28–32 years (16.89%), 33–37 years (15.28%), 38–42 years (15.82%), 43–47 years (11.53%) and 48 years and above (12.06%). Interestingly, 96.78% of respondents were frequent buyers of fashion clothes and textiles. In addition, 73.99% of buyers prefer to buy using the online medium. Further 80.16% of buyers think CSR spread positivity about the brand nowadays in Pakistan. However, around half of respondents respond that CSR increases the green innovation performance however the other half think the opposite.

4.2. Measurement model

Overall, the outcomes of the measurement model are satisfactory in Table 2. Specifically, the coefficients of Cronbach alpha and construct reliability is above the threshold points of 0.70 (Hair et al., 2017). Value for Cronbach alpha range from 0.832 to 0.917 and 0.899 to 0.935 for CR for all constructs. It shows higher contracts reliability as all constructs are significantly above the minimum value of 0.70. The outcomes of FD are above 0.70 for all items or indicators of constructs except GIP1 (0.646) hence deleted for structural model assessment. It confirms that the indicators within each construct are reliable to measure the particular construct.

Table 2. Descriptive statistics and measurement model outcomes.

Constructs	Code	FD	α	CR	AVE	M	SD
Corporate Social Responsibility (CSR)	CSR1	0.888	0.910	0.933	0.736	3.868	1.021
	CSR2	0.850					
	CSR3	0.875					
	CSR4	0.799					
	CSR5	0.875					
Brand Trust (BT)	BT1	0.857	0.832	0.899	0.748	3.733	1.036
	BT2	0.864					
	BT3	0.873					
Brand Loyalty (BL)	BL1	0.895	0.893	0.922	0.704	3.947	1.089
	BL2	0.836					
	BL3	0.844					
	BL4	0.723					
	BL5	0.886					
Sustainable Purchase Intentions (SPI)	SPI1	0.882	0.917	0.935	0.707	3.860	1.071
	SPI2	0.834					
	SPI3	0.807					
	SPI4	0.855					
	SPI5	0.858					
	SPI6	0.806					
Green Innovation Performance (GIP) Deleted	GIP1	0.646	0.879	0.913	0.681	3.931	1.071
	GIP2	0.89					
	GIP3	0.819					
	GIP4	0.891					
	GIP5	0.853					

Note. FD = Factor Loadings, CR = Construct Reliability, AVE = Average Variance Extracted, and α = Cronbach Alpha, M = Mean, SD = Standard Deviation.

Source: Authors collection.

Table 3. Cross loadings.

Items	BL	BT	CSR	GIP	SPI
BL1	0.895	0.620	0.741	0.743	0.826
BL2	0.836	0.654	0.700	0.724	0.768
BL3	0.844	0.612	0.681	0.719	0.729
BL4	0.723	0.553	0.570	0.595	0.664
BL5	0.886	0.679	0.758	0.764	0.858
BT1	0.600	0.857	0.658	0.710	0.608
BT2	0.664	0.864	0.696	0.692	0.705
BT3	0.665	0.873	0.711	0.715	0.649
CSR1	0.748	0.659	0.888	0.720	0.817
CSR2	0.716	0.699	0.850	0.680	0.711
CSR3	0.729	0.666	0.875	0.718	0.737
CSR4	0.613	0.693	0.799	0.657	0.651
CSR5	0.734	0.705	0.875	0.709	0.806
GIP1	0.552	0.658	0.565	0.646	0.539
GIP2	0.709	0.740	0.682	0.890	0.745
GIP3	0.689	0.665	0.648	0.819	0.659
GIP4	0.726	0.681	0.723	0.891	0.762
GIP5	0.796	0.634	0.718	0.853	0.882
SPI1	0.796	0.634	0.718	0.853	0.882
SPI2	0.737	0.612	0.672	0.720	0.834
SPI3	0.732	0.553	0.662	0.693	0.807
SPI4	0.742	0.623	0.687	0.690	0.855
SPI5	0.886	0.679	0.758	0.764	0.858
SPI6	0.734	0.705	0.875	0.709	0.806

Source: Authors collection.

The AVE value for every construct is higher than the 0.50 threshold (Hair et al., 2017). Therefore, the convergent validity is also maintained for all constructs in the model.

There were three measures (cross-loadings, Fornell and Larcker ratio, and HTMT ratio) employed for discriminant validity measurement. The results of all three methods to measure discriminant validity are depicted in Tables 3–5, respectively. The outcomes in Table 3 confirm that all bold values are higher than their behind values, therefore the results for cross-loadings are satisfactory (Hair et al., 2017). Likewise, the findings for Fornell and Larcker are satisfactory because the square root of all diagonal values in bold is higher than the below values (Hair et al., 2011); thus discriminant validity is maintained. However, values of HTMT ratio demonstrate an issue of multicollinearity as several values are higher than 0.85 or 0.90 (Rajalahti & Kvalheim, 2011). In overview, the results of the two measures are satisfactory therefore, the discriminant validity is maintained. The graphical representation of measurement model assessment is pictorially represented in Figure 2.

4.3. Structural model outcomes

Overall, the current research model proposes 12 direct and indirect hypotheses, among them 7 are direct and 5 are indirect hypotheses. Corporate social responsibility implicitly predicts sustainable purchase intentions and green innovation performance. The results for structural model (Figure 3) estimation are depicted in Table 6. Hence *H1* and *H2* are accepted and confirmed a positive impact of corporate social

Table 4. Fornell and Larcker criterion.

	BL	BT	CSR	GIP	SPI
BL	0.893				
BT	0.745	0.865			
CSR	0.827	0.797	0.885		
GIP	0.848	0.816	0.813	0.825	
SPI	0.720	0.757	0.870	0.808	0.841

Source: Authors collection.

Table 5. HTMT ratio.

	BL	BT	CSR	GIP	SPI
BL	–				
BT	0.763	–			
CSR	0.613	0.860	–		
GIP	0.754	0.913	0.899	–	
SPI	0.012	0.863	0.947	0.921	–

Source: Authors collection.

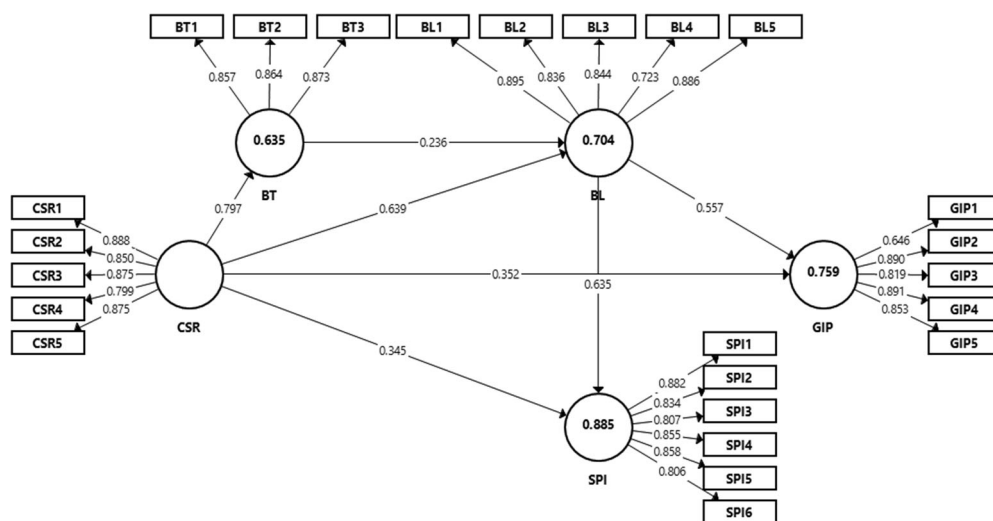

Figure 2. Measurement model.

Source: Authors collection.

responsibility on sustainable purchase intentions and green innovation performance as p value = 0.000; t statistics = 8.551 and p value = 0.000; t statistics = 4.743, respectively. Likewise, corporate social responsibility showed a positive impact on brand trust and brand loyalty. The outcomes p value = 0.000; t statistics = 36.161 and p value = 0.000; t statistics = 14.463 confirmed that $H3$ and $H4$ are accepted and there exist a statistically significant relationship. Brand trust was also proved as a source to increases brand loyalty under p value = 0.000; t statistics = 5.197 hence $H5$ was accepted. Afterward, there exists a positive effect of brand loyalty on sustainable purchase intentions and green innovation performance as p value = 0.000; t statistics = 16.076 and p value = 0.000; t statistics = 8.427, hence $H6$ and $H7$ were confirmed. All direct hypotheses were accepted.

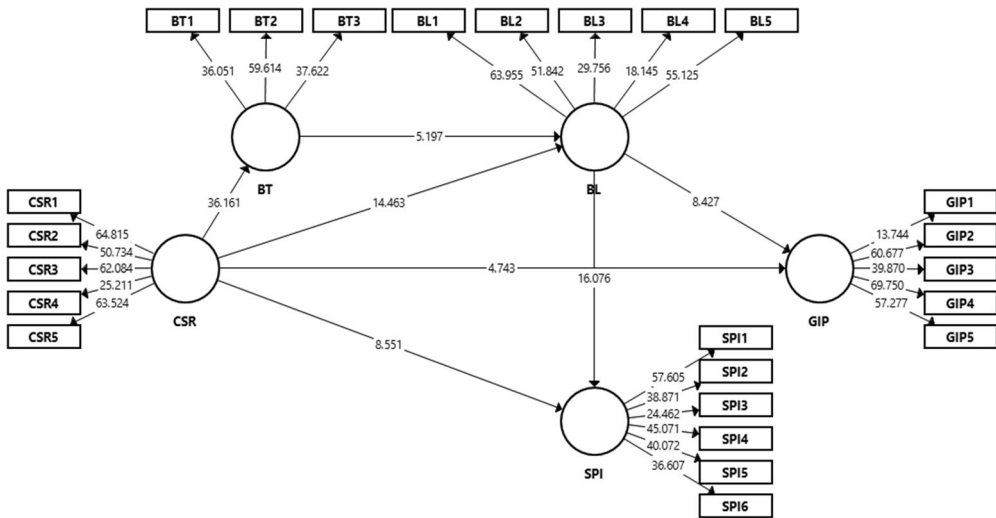

Figure 3. Structural model.
Source: Authors collection.

Table 6. Direct and indirect effects.

H	Paths	O	M	SD	T statistics	p values	R ²	f ²	Q ²
H1	CSR → SPI	0.345	0.345	0.040	8.551	0.000	0.884	0.328	0.617
H2	CSR → GIP	0.352	0.352	0.074	4.743	0.000	0.757	0.162	0.510
H3	CSR → BT	0.797	0.797	0.022	36.161	0.000	0.634	1.736	0.471
H4	CSR → BL	0.639	0.638	0.044	14.463	0.000	0.702	0.503	0.491
H5	BT → BL	0.236	0.237	0.045	5.197	0.000		0.068	
H6	BL → SPI	0.635	0.635	0.040	16.076	0.000		1.111	
H7	BL → GIP	0.557	0.557	0.066	8.427	0.000		0.408	
H8	CSR → BT → BL	0.188	0.189	0.036	5.161	0.000			
H9	CSR → BL → GIP	0.356	0.355	0.043	8.339	0.000			
H10	CSR → BL → SPI	0.406	0.406	0.040	10.218	0.000			
H11	CSR → BT → BL → SPI	0.119	0.120	0.024	5.056	0.000			
H12	CSR → BT → BL → GIP	0.105	0.106	0.026	3.950	0.000			

Note. Original Sample = O, Sample Mean M, Standard Deviation = SD, H = Hypothesis.
Source: Authors collection.

H8 was also accepted, where brand trust partially mediates the relationship between corporate social responsibility and brand loyalty as p value = 0.000; t statistics = 5.161. H9 and H10 were accepted also, where brand loyalty partially mediates the relationship between corporate social responsibility and sustainable purchase intentions, and corporate social responsibility and green innovation performance. As results confirmed it as p value = 0.000; t statistics = 8.339 and p value = 0.000; t statistics = 10.218. There were two serial mediations were proposed and both were accepted. H11 was accepted where p value = 0.000; t statistics = 5.056 and confirmed a statistically significant serial partial mediation by brand trust and brand loyalty between social corporate sustainability and sustainable purchase intentions. In the same manner, H12 was accepted where brand trust and brand loyalty serially mediate the relationship between corporate social responsibility and green purchase innovation as the outcomes are as p value = 0.000; t statistics = 3.950.

5. Discussion and implications

The current study was hypothesized on modeling the impact of corporate social responsibility on sustainable purchase intentions. Moreover, it has also addressed the mediating role of brand trust and brand loyalty in this whole scenario. Sustainable purchase intention has been an under studied factor leaving a great space to be filled in this modern era. The hypotheses of the study have been analyzed firstly for the demography of the respondents. The age of the respondents ranged from 18 to 48 years and above. Then with measurement algorithm, the reliability and validity of data were checked and then with structural algorithm for the measurement of hypotheses of the study. The results obtained from the data were mostly supported. Some of the results were in accordance with the previous studies while some were not. The possible reasons for the difference of results are discussed here.

The results are shown in the form of path models; the direct hypotheses are shown as direct effects while indirect paths show the indirect effects of mediation. Overall, corporate social responsibility has proved to be the major contributor to the proposed conceptual framework of the study. This is because corporate social responsibility has been existed in any organization at every level.

There were twelve hypotheses developed in this study, seven were direct and five were indirect. The first and the second hypotheses were regarding corporate social responsibility, sustainable purchase intention and green innovation performance. These hypotheses were accepted with a possible logic behind as the role of CSR in providing sustainable purchase intention and green innovation performance supported by the previous studies (Ali & Sohail, 2018; Hong et al., 2020; Qasim et al., 2017; Shahzad et al., 2020). Similar results were found in their researches so it provided a continuing support for our results. Similarly, regarding H_3 and H_5 , corporate social responsibility showed a positive impact on brand trust and brand loyalty. These results were also in accordance with many researchers of the past and the reason behind was the prevalence of corporate social responsibilities which positively impact brand trust and brand loyalty (Barnes, 2011; Dapi & Phiri, 2015; Rivera et al., 2019). Brand trust was also proved as a source to increase brand loyalty hence, H_4 was accepted. These results were also similar to the findings of earlier research of Kwan Soo Shin et al. (2019) and Bozbay and Karakuş Başlar (2020) which proved its significance even further. Afterward, there existed a positive effect of brand loyalty on sustainable purchase intentions and green innovation performance hence, H_6 and H_7 were confirmed. These results were similar to those of Hameed and Kanwal (2018). It happens when brand loyalty leads to sustainable purchase intention and green innovation performance. All direct hypotheses were accepted showing the strong impact between them and supporting our model.

H_8 was also accepted, where brand trust partially mediates the relationship between corporate social responsibility and brand loyalty. These results were in accordance to many researcher but many were against it as well (Cuong, 2020; Villagra et al., 2021). These research studies found significant mediation of brand trust, but our results provided insight of partial mediation of brand trust as the variables of our research were different from the variables used in their studies. However, the mediating role was confirmed as proposed by them. H_9 and H_{10} were accepted

also, where brand loyalty partially mediates the relationship between corporate social responsibility and sustainable purchase intentions, and corporate social responsibility and green innovation performance. Some previous studies were also carried out the mediating effects of brand loyalty (Tunjungsari et al., 2020). There were two serial mediations proposed and both were accepted. *H11* was accepted and confirmed a statistically significant serial partial mediation by brand trust and brand loyalty between social corporate sustainability and sustainable purchase intentions. In the same manner, *H12* was accepted where brand trust and brand loyalty serially mediate the relationship between corporate social responsibility and green purchase innovation as the outcomes (Zeren & Kara, 2020). The previous work of researchers proved the mediating link of brand trust and brand loyalty but serial mediation of brand trust and brand loyalty was absent in past so, our research will provide a reference for the serial mediation of the both in this regard.

The results obtained in this study have many implications for the future studies and policy making who are interested in these areas of study for understanding the underlying reasons for corporate social responsibilities. However, side by side, there are certain limitations as well of the study. One of the limitations of the study is that this study can be replicated in other parts of the world where free economies are practiced giving dissimilar results. Also, in other sectors of the business and education sector is the biggest hub for corporate social responsibilities where this study can produce more interesting results. By examining CSR practices in a developing nation like Pakistan, this study contributes to the existing knowledge and fills a gap that existed when only established markets were researched. It's the first time we've looked at brand loyalty and trust as mediators in the context of Pakistan. The findings showed that strong CSR may influence sustainable buying intentions as well as green innovation performance for a more sustainable environment. It also has a lot to offer in other markets and in relation to other countries.

6. Conclusion and future scope

Social corporate sustainability has become an integral antecedent of sustainable purchase intentions and green innovation performance in modern times. Recently, the social sustainability area has got the attention of researchers in almost all sectors. However, how brand trust and brand loyalty are crucial to buffer the relationship between social corporate sustainability and sustainable purchase intention is remain an area of interest. Moreover, the ways green technologies are increasingly popular in the current era. Because innovation technologies are the key elements to eliminate pollution, waste management, and corporate environmental management. In addition, the predictors of green innovation performance need to be explored yet. Therefore, current research investigated the direct impact of corporate social responsibility on sustainable purchase intentions and green innovation performance in the textile and clothing industry of Pakistan. Additionally, it explores the mediating roles of brand trust and brand loyalty.

This research used the partial least structural equation modeling (PLS-SEM) estimation technique to investigate the relationship between constructs. The data

collection method was a self-administrated survey via Google-Forms and a convenient sampling technique was employed. The data was collected from 373 textile and clothing buyers from Pakistan. The results showed that corporate social responsibility has a positive impact on the sustainable purchase intentions of Pakistani buyers. Likewise, green innovation performance can be increased through increasing CSR. Brand loyalty partially mediates the linkage between CSR and sustainable purchase intentions and green innovation technology. Brand trust stood as a potential mediator between CSR and brand loyalty. Interestingly, brand trust and brand loyalty serially mediate the linkage between CSR and sustainable purchase intentions and CSR and green innovation performance. These findings suggest several managerial implications for textile and fashion brands in Pakistan. Particularly, policymakers should focus on CSR to enhance the green innovation performance in the country. Current research is conducted in the Pakistani context and the point of focus was Pakistani fashion and textile product buyers. Therefore, the findings demonstrate a cultural flavor hence findings may vary in another part of the work. Similarly, the current research is focused on the textile, clothing, and fashion brands buyers therefore outcomes can be different if applied to any other sector of industry. In addition, current research does not have any moderating construct, so future research should include potential moderators in the model and check the buffer impact of moderating roles.

These conclusions have a number of implications, emphasizing the creation of socially responsible activities and environmentally motivated environment as key to long planning to achieve and sustain competitiveness in the textiles sector. These are the efforts that should be widely considered as part of the long-term planning to achieve and sustain competitiveness in the textiles sector. Organizations should also reconsider the perception that these procedures are a cost when, in reality, they are an investment that protects the firm's continuity and viability. Green practices assist in ethical and socially responsible corporate conduct, which does not conflict with wealth maximization, but is beneficial to all stakeholders. In the public sector, policymakers might give incentives and implement regulations to encourage businesses to adopt sustainable practices and green technologies, which would boost their competitiveness and have a cascading impact across the supply chain, affecting regional and national levels.

Furthermore, our research contributes to the understanding of the influence of CSR on long-term purchasing intentions and green innovation performance, demonstrating a more efficient use of energy and natural resources, resulting in increased productivity and, by extension, profitability. CSR fosters an innovative environment that, through the application of social, environmental, and sustainability controls, can result in the development of new business models, products, services, or processes that improve firm and supply chain productivity, with benefits that eventually trickle down to the host community. Other factors which may promote competitiveness, like the corporate environment, green management, environment where people contribute, and environmental capability at the corporate level, should be included in future study. Another concept that could be included is green supply chain management, which refers to corporate practices aimed at improving the transactional and cooperative interface with suppliers and clients, as CSR and

green innovation are more likely to deliver impact and long-term competitiveness when implemented throughout the supply chain. These measures include supplier selection, as well as the establishment of joint improvement initiatives aimed at improving environmental performance.

Disclosure statement

No potential conflict of interest was reported by the authors.

Funding

This research was supported by the National Natural Science Foundation of China [Grant 71972099], Natural science research project of colleges and universities in Jiangsu Province [Grant 18KJB520007] and Nanjing University of Posts and Telecommunications [Grant JG00719JX85, NY220062 and NY220206].

References

- Abrams, R., Han, S., & Hossain, M. T. (2021). Environmental performance, environmental management and company valuation. *Journal of Global Responsibility*, 12(4), 400–415. <https://doi.org/10.1108/JGR-10-2020-0092>
- Achabou, M. A. (2020). The effect of perceived CSR effort on consumer brand preference in the clothing and footwear sector. *European Business Review*, 32(2), 317–347. <https://doi.org/10.1108/EBR-11-2018-0198>
- Adelodun, B., Kareem, K. Y., Kumar, P., Kumar, V., Choi, K. S., Yadav, K. K., Yadav, A., El-Denglawey, A., Cabral-Pinto, M., Son, C. T., Krishnan, S., & Khan, N. A. (2021). Understanding the impacts of the COVID-19 pandemic on sustainable agri-food system and agroecosystem decarbonization nexus: A review. *Journal of Cleaner Production*, 318, 128451. <https://doi.org/10.1016/j.jclepro.2021.128451>
- Aghaei, M., Ghasemian Sahebi, A., & Kordheydari, R. (2021). The effect of COVID-19 on marketing innovations and corporate social responsibility (case study: active companies in food industry). *International Journal on Customer Relations*, 8(2), 15–26.
- Ahmad, N., Scholz, M., Ullah, Z., Arshad, M. Z., Sabir, R. I., & Khan, W. A. (2021). The nexus of CSR and co-creation: A roadmap towards consumer loyalty. *Sustainability*, 13(2), 523. <https://doi.org/10.3390/su13020523>
- Akbari, M., Nazarian, A., Foroudi, P., Seyyed Amiri, N., & Ezatabadipoor, E. (2021). How corporate social responsibility contributes to strengthening brand loyalty, hotel positioning and intention to revisit? *Current Issues in Tourism*, 24(13), 1897–1917. <https://doi.org/10.1080/13683500.2020.1800601>
- Alam, M. M. D., Al Karim, R., & Habiba, W. (2021). The relationship between CRM and customer loyalty: the moderating role of customer trust. *International Journal of Bank Marketing*, 39(7), 1248–1272. <https://doi.org/10.1108/IJBM-12-2020-0607>
- Albort-Morant, G., Leal-Millán, A., & Cepeda-Carrión, G. (2016). The antecedents of green innovation performance: A model of learning and capabilities. *Journal of Business Research*, 69(11), 4912–4917. <https://doi.org/10.1016/j.jbusres.2016.04.052>
- Ali, S. S., & Kaur, R. (2021). Effectiveness of corporate social responsibility (CSR) in implementation of social sustainability in warehousing of developing countries: A hybrid approach. *Journal of Cleaner Production*, 324, 129154. <https://doi.org/10.1016/j.jclepro.2021.129154>

- Ali, F., & Sohail, M. (2018). Effects of corporate social responsibility on consumer purchase intention. *Pakistan Journal of Humanities and Social Sciences*, 6(4). <https://doi.org/10.52131/pjhss.2018.0604.0059>
- Al-Swidi, A., & Saleh, R. M. (2021). How green our future would be? An investigation of the determinants of green purchasing behavior of young citizens in a developing Country. *Environment, Development and Sustainability*, 23(9), 13436–13468. <https://doi.org/10.1007/s10668-020-01220-z>
- Ameen, N., Hosany, S., & Paul, J. (2022). The personalisation-privacy paradox: Consumer interaction with smart technologies and shopping mall loyalty. *Computers in Human Behavior*, 126, 106976. <https://doi.org/10.1016/j.chb.2021.106976>
- Asiaei, K., Bontis, N., Alizadeh, R., & Yaghoubi, M. (2021). Green intellectual capital and environmental management accounting: Natural resource orchestration in favor of environmental performance. *Business Strategy and the Environment*. <https://doi.org/10.1002/bse.2875>
- Babatunde, K. A., Negash, B. M., Jufar, S. R., Ahmed, T. Y., & Mojid, M. R. (2022). Adsorption of gases on heterogeneous shale surfaces: A review. *Journal of Petroleum Science and Engineering*, 208, 109466. <https://doi.org/10.1016/j.petrol.2021.109466>
- Barnes, A. (2011). *Corporate social responsibility and its effects on brand trust* [PhD dissertation]. Auckland University of Technology.
- Bass, A. E., & Grøgaard, B. (2021). *The long-term energy transition: Drivers, outcomes, and the role of the multinational enterprise*. Springer.
- Batt, V., Holzer, M., Bruhn, M., & Tuzovic, S. (2021). Effects of sponsorship quality and quantity on employee brand behavior. *Journal of Brand Management*, 28(5), 495–509. <https://doi.org/10.1057/s41262-021-00242-w>
- Ben Amor, N., & Ben Yahia, I. (2021). Investigating Blockchain technology effects on online platforms transactions: Do risk aversion and Technophilia matter? *Journal of Internet Commerce*, 1–26. <https://doi.org/10.1080/15332861.2021.1961188>
- Bianchi, G., Testa, F., Tessitore, S., & Iraldo, F. (2021). How to embed environmental sustainability: The role of dynamic capabilities and managerial approaches in a life cycle management perspective. *Business Strategy and the Environment*. <https://doi.org/10.1002/bse.2889>
- Boudreaux, C., Clarke, G., & Jha, A. (2021). Social capital and small informal business productivity: the mediating roles of financing and customer relationships. *Small Business Economics*, 1–22. <https://doi.org/10.1007/s11187-021-00560-y>
- Bozbay, Z., & Karakuş Başlar, E. (2020). Impact of brand trust on brand loyalty: Mediating role of brand affect. *Journal of Academic Research in Economics*, 12, 247–259.
- Brydges, T. (2021). Closing the loop on take, make, waste: Investigating circular economy practices in the Swedish fashion industry. *Journal of Cleaner Production*, 293, 126245. <https://doi.org/10.1016/j.jclepro.2021.126245>
- Byun, K. K., Ma, M., Kim, K., & Kang, T. (2021). Buying a new product with inconsistent product reviews from multiple sources: The role of information diagnosticity and advertising. *Journal of Interactive Marketing*, 55, 81–103. <https://doi.org/10.1016/j.intmar.2021.01.003>
- Cambra-Fierro, J., Flores-Hernández, J., Perez, L., & Valera-Blanes, G. (2020). CSR and branding in emerging economies: The effect of incomes and education. *Corporate Social Responsibility and Environmental Management*, 27(6), 2765–2776. <https://doi.org/10.1002/csr.2000>
- Cantillo, J., Martín, J. C., & Román, C. (2021). Determinants of fishery and aquaculture products consumption at home in the EU28. *Food Quality and Preference*, 88, 104085. <https://doi.org/10.1016/j.foodqual.2020.104085>
- Chandrasekar, K., Selvanayagam, K., & Rehman, V. (2021). Responsibility finds a way: A typology and framework development approach towards public sector crisis management. *International Journal of Strategic Communication*, 15(4), 328–356.
- Cho, M., Bonn, M. A., & Jung, H. S. (2021). What drives restaurant competitive productivity (CP): A comprehensive examination at meso-micro levels. *International Journal of*

- Contemporary Hospitality Management*, 33(9), 3065–3090. <https://doi.org/10.1108/IJCHM-09-2020-1040>
- Cuong, D. (2020). The role of brand trust as a mediator in the relationship between brand satisfaction and purchase intention. *International Journal of Psychosocial Rehabilitation*, 24, 1475–7192. <https://doi.org/10.37200/IJPR/V24I6/PR261416>
- Dapi, B., & Phiri, M. (2015). The impact of corporate social responsibility on brand loyalty. *Journal of Governance and Regulation*, 4(4), 8–16. https://doi.org/10.22495/jgr_v4_i1_p1
- Dhir, A., Talwar, S., Sadiq, M., Sakashita, M., & Kaur, P. (2021). Green apparel buying behaviour: A stimulus–organism–behaviour–consequence (SOBC) perspective on sustainability-oriented consumption in Japan. *Business Strategy and the Environment*, 30(8), 3589–3605. <https://doi.org/10.1002/bse.2821>
- Duque-Grisales, E., & Aguilera-Caracuel, J. (2021). Environmental, social and governance (esg) scores and financial performance of multilatinas: Moderating effects of geographic international diversification and financial slack. *Journal of Business Ethics*, 168(2), 315–334. <https://doi.org/10.1007/s10551-019-04177-w>
- El-Kassar, A.-N., & Singh, S. K. (2019). Green innovation and organizational performance: The influence of big data and the moderating role of management commitment and HR practices. *Technological Forecasting and Social Change*, 144, 483–498. <https://doi.org/10.1016/j.techfore.2017.12.016>
- Foroudi, P. (2019). Influence of brand signature, brand awareness, brand attitude, brand reputation on hotel industry's brand performance. *International Journal of Hospitality Management*, 76, 271–285. <https://doi.org/10.1016/j.ijhm.2018.05.016>
- Franco, D. (2020). Informality and dissent: The culture of self-sufficiency of the American rural poor. In *Informality through sustainability* (pp. 67–81). Routledge.
- Freeman, R. B. (1984). Longitudinal analyses of the effects of trade unions. *Journal of Labor Economics*, 2(1), 1–26.
- González-Rodríguez, M. R., Díaz-Fernández, M. C., Shi, F., & Okumus, F. (2021). Exploring the links among corporate social responsibility, reputation, and performance from a multi-dimensional perspective. *International Journal of Hospitality Management*, 99, 103079. <https://doi.org/10.1016/j.ijhm.2021.103079>
- Guan, J., Wang, W., Guo, Z., Chan, J. H., & Qi, X. (2021). Customer experience and brand loyalty in the full-service hotel sector: the role of brand affect. *International Journal of Contemporary Hospitality Management*, 33(5), 1620–1645. <https://doi.org/10.1108/IJCHM-10-2020-1177>
- Hair, J. F., Hult, G. T. M., Ringle, C. M., Sarstedt, M., & Thiele, K. O. (2017). Mirror, mirror on the wall: A comparative evaluation of composite-based structural equation modeling methods. *Journal of the Academy of Marketing Science*, 45(5), 616–632. <https://doi.org/10.1007/s11747-017-0517-x>
- Hair, J. F., Ringle, C. M., & Sarstedt, M. (2011). PLS-SEM: Indeed a silver bullet. *Journal of Marketing Theory and Practice*, 19(2), 139–152. <https://doi.org/10.2753/MTP1069-6679190202>
- Hall, E., Menzies, J., Zutshi, A., & Creed, A. (2021). Opera participants' perceptions of brand resonance. *International Journal of Consumer Studies*. <https://doi.org/10.1111/ijcs.12743>
- Hameed, S., & Kanwal, M. (2018). Effect of brand loyalty on purchase intention in cosmetics industry. *Research in Business and Management*, 5(1), 25. <https://doi.org/10.5296/rbm.v5i1.12704>
- Hong, M., Drakeford, B., & Zhang, K. (2020). The impact of mandatory CSR disclosure on green innovation: evidence from China. *Green Finance*, 2(3), 302–322. <https://doi.org/10.3934/GF.2020017>
- Hong, J. J., Yang, J., Wooldridge, B. R., & Bhappu, A. D. (2021). 'Sharing consumers' brand storytelling: Influence of consumers' storytelling on brand attitude via emotions and cognitions. *Journal of Product & Brand Management* (ahead-of-print). <https://doi.org/10.1108/JPBM-07-2019-2485>

- Hooi, L. W., Liu, M.-S., & Lin, J. J. J. (2021). Green human resource management and green organizational citizenship behavior: Do green culture and green values matter? *International Journal of Manpower* (ahead-of-print). <https://doi.org/10.1108/IJM-05-2020-0247>
- Hristov, I., Appolloni, A., Chirico, A., & Cheng, W. (2021). The role of the environmental dimension in the performance management system: A systematic review and conceptual framework. *Journal of Cleaner Production*, 293, 126075. <https://doi.org/10.1016/j.jclepro.2021.126075>
- Hwang, J., Choe, J. Y. (J.), Kim, H. M., & Kim, J. J. (2021). Human baristas and robot baristas: How does brand experience affect brand satisfaction, brand attitude, brand attachment, and brand loyalty? *International Journal of Hospitality Management*, 99, 103050. <https://doi.org/10.1016/j.ijhm.2021.103050>
- Ibrahim, B., & Aljarah, A. (2021). The era of Instagram expansion: matching social media marketing activities and brand loyalty through customer relationship quality. *Journal of Marketing Communications*, 1–25. <https://doi.org/10.1080/13527266.2021.1984279>
- Islam, T., Islam, R., Pitafi, A. H., Xiaobei, L., Rehmani, M., Irfan, M., & Mubarak, M. S. (2021). The impact of corporate social responsibility on customer loyalty: The mediating role of corporate reputation, customer satisfaction, and trust. *Sustainable Production and Consumption*, 25, 123–135. <https://doi.org/10.1016/j.spc.2020.07.019>
- Javaid, M., Haleem, A., Singh, R. P., Suman, R., & Rab, S. (2021). Role of additive manufacturing applications towards environmental sustainability. *Advanced Industrial and Engineering Polymer Research*, 4(4), 312–322. <https://doi.org/10.1016/j.aiepr.2021.07.005>
- Kataria, S., Saini, V. K., Sharma, A. K., Yadav, R., & Kohli, H. (2021). An integrative approach to the nexus of brand loyalty and corporate social responsibility. *International Review on Public and Nonprofit Marketing*, 18(3), 361–385. <https://doi.org/10.1007/s12208-021-00277-4>
- Kazmi, S. Q., & Rahman, U. (2021). Developing factors of sustainable purchase intentions of luxury brands mediated by power distance beliefs. *International Journal of Innovation, Creativity and Change. Www.Ijicc.Net*, 15(7), 2021.
- Khan, P. A., Johl, S. K., & Johl, S. K. (2021). Does adoption of ISO 56002-2019 and green innovation reporting enhance the firm sustainable development goal performance? An emerging paradigm. *Business Strategy and the Environment*, 30(7), 2922–2936. <https://doi.org/10.1002/bse.2779>
- Kim, S., & Lee, H. (2019). The effect of CSR fit and CSR authenticity on the brand attitude. *Sustainability*, 12(1), 275. <https://doi.org/10.3390/su12010275>
- Klein, A., & Sharma, V. M. (2022). Consumer decision-making styles, involvement, and the intention to participate in online group buying. *Journal of Retailing and Consumer Services*, 64, 102808. <https://doi.org/10.1016/j.jretconser.2021.102808>
- Klößner, M., Schmidt, C., & Wagner, S. M. (2021). The impact of the COVID-19 pandemic on shareholder value. *Academy of Management Proceedings*, 2021(1), 11144. <https://doi.org/10.5465/AMBPP.2021.45>
- Kursan Milaković, I. (2021). Purchase experience during the COVID-19 pandemic and social cognitive theory: The relevance of consumer vulnerability, resilience, and adaptability for purchase satisfaction and repurchase. *International Journal of Consumer Studies*, 45(6), 1425–1442. <https://doi.org/10.1111/ijcs.12672>
- Kwan Soo Shin, S., Amenuvor, F. E., Basilisco, R., & Owusu-Antwi, K. (2019). Brand trust and brand loyalty: A moderation and mediation perspective. *Current Journal of Applied Science and Technology*, 38(4), 1–17. <https://doi.org/10.9734/cjast/2019/v38i430376>
- Le, A. N. H., Khoi, N. H., & Nguyen, D. P. (2021). Unraveling the dynamic and contingency mechanism between service experience and customer engagement with luxury hotel brands. *International Journal of Hospitality Management*, 99, 103057. <https://doi.org/10.1016/j.ijhm.2021.103057>
- Lentz, M., Berezan, O., & Raab, C. (2021). Uncovering the relationship between revenue management and hotel loyalty programs. *Journal of Revenue and Pricing Management*. <https://doi.org/10.1057/s41272-021-00331-0>

- Le, T. T., Ngo, H. Q., & Aureliano-Silva, L. (2021). Contribution of corporate social responsibility on SMEs' performance in an emerging market – The mediating roles of brand trust and brand loyalty. *International Journal of Emerging Markets* (ahead-of-print). <https://doi.org/10.1108/IJOEM-12-2020-1516>
- Liu, F., Lai, K.-H., Wu, J., & Duan, W. (2021). Listening to online reviews: A mixed-methods investigation of customer experience in the sharing economy. *Decision Support Systems*, 149, [113609]. <https://doi.org/10.1016/j.dss.2021.113609>.
- Loh, Z., & Hassan, S. H. (2021). Consumers' attitudes, perceived risks and perceived benefits towards repurchase intention of food truck products. *British Food Journal* (ahead-of-print). <https://doi.org/10.1108/BFJ-03-2021-0216>
- Ltifi, M., & Hichri, A. (2021). The effects of corporate governance on the customer's recommendations: a study of the banking sector at the time of COVID-19. *Journal of Knowledge Management, ahead-of-print*(ahead-of-print) <https://doi.org/10.1108/JKM-06-2020-0471>
- Lu, J., Ren, L., Zhang, C., Rong, D., Ahmed, R. R., & Streimikis, J. (2020). Modified Carroll's pyramid of corporate social responsibility to enhance organizational performance of SMEs industry. *Journal of Cleaner Production*, 271, 122456. <https://doi.org/10.1016/j.jclepro.2020.122456>
- Madhavaram, S. (2021). Shelby D. Hunt's contributions to the marketing discipline: Research programs, impact, and compelling opportunities. *Journal of Global Scholars of Marketing Science*, 31(2), 125–129. <https://doi.org/10.1080/21639159.2020.1785919>
- Makhloufi, L., Laghouag, A. A., Meirun, T., & Belaid, F. (2021). Impact of green entrepreneurship orientation on environmental performance: The natural resource-based view and environmental policy perspective. *Business Strategy and the Environment*. <https://doi.org/10.1002/bse.2902>
- Matharu, M., Jain, R., & Kamboj, S. (2020). Understanding the impact of lifestyle on sustainable consumption behavior: A sharing economy perspective. *Management of Environmental Quality: An International Journal*, 32(1), 20–40. <https://doi.org/10.1108/MEQ-02-2020-0036>
- Mathiyazhagan, K., Agarwal, V., Appoloni, A., Saikouk, T., & Gnanavelbabu, A. (2021). Integrating lean and agile practices for achieving global sustainability goals in Indian manufacturing industries. *Technological Forecasting and Social Change*, 171, 120982. <https://doi.org/10.1016/j.techfore.2021.120982>
- Melović, B., Šehović, D., Karadžić, V., Dabić, M., & Ćirović, D. (2021). Determinants of Millennials' behavior in online shopping – Implications on consumers' satisfaction and e-business development. *Technology in Society*, 65, 101561. <https://doi.org/10.1016/j.techsoc.2021.101561>
- Mukherjee, B., & Chandra, B. (2021). Unravelling the differential effects of pride and guilt along with values on green intention through environmental concern and attitude. *Kybernetes* (ahead-of-print). <https://doi.org/10.1108/K-04-2021-0336>
- Muthu Lakshmi, S. T., & Suresh, M. (2021). Modelling of factors influencing brand commitment of FMCG products: A TISM approach. *Materials Today: Proceedings*. <https://doi.org/10.1016/j.matpr.2021.01.835>
- Nelson, J. L., & Kim, S. J. (2021). Improve trust, increase loyalty? Analyzing the relationship between news credibility and consumption. *Journalism Practice*, 15(3), 348–365. <https://doi.org/10.1080/17512786.2020.1719874>
- Neumann, H. L., Martinez, L. M., & Martinez, L. F. (2021). Sustainability efforts in the fast fashion industry: consumer perception, trust and purchase intention. *Sustainability Accounting, Management and Policy Journal*, 12(3), 571–590. <https://doi.org/10.1108/SAMPJ-11-2019-0405>
- Nyamrunda, F. C., & Freeman, S. (2021). Strategic agility, dynamic relational capability and trust among SMEs in transitional economies. *Journal of World Business*, 56(3), 101175. <https://doi.org/10.1016/j.jwb.2020.101175>
- Othman, B., He, W., Huang, Z., Xi, J., & Ramsey, T. (2021). The effects on service value and customer retention by integrating after sale service into the traditional marketing mix model

- of clothing store brands in China. *Environmental Technology & Innovation*, 23, 101784. <https://doi.org/10.1016/j.eti.2021.101784>
- Qasim, S., Siam, M., & Md Salleh, S. (2017). The impact of CSR on consumers purchase intention: The mediating role of corporate reputation and moderating peers pressure. *International Journal of Supply Chain Management*, 6, 239–245.
- Rajalahti, T., & Kvalheim, O. M. (2011). Multivariate data analysis in pharmaceuticals: A tutorial review. *International Journal of Pharmaceutics*, 417(1), 280–290. <https://doi.org/10.1016/j.ijpharm.2011.02.019>
- Raza-Ullah, T. (2021). When does (not) a cooperative relationship matter to performance? An empirical investigation of the role of multidimensional trust and distrust. *Industrial Marketing Management*, 96, 86–99. <https://doi.org/10.1016/j.indmarman.2021.03.004>
- Rhein, S., & Schmid, M. (2020). Consumers' awareness of plastic packaging: More than just environmental concerns. *Resources, Conservation and Recycling*, 162, 105063. <https://doi.org/10.1016/j.resconrec.2020.105063>
- Rivera, J., Bigne, E., & Curras-Perez, R. (2019). Effects of Corporate Social Responsibility on consumer brand loyalty. *Review of Business Management*, 20(3), 395–415. <https://doi.org/10.7819/rbgn.v21i3.4003>
- Rizomyliotis, I., Poulis, A., Konstantoulaki, K., & Giovanis, A. (2021). Sustaining brand loyalty: The moderating role of green consumption values. *Business Strategy and the Environment*, 30(7), 3025–3039. <https://doi.org/10.1002/bse.2786>
- Safeer, A. A., Yuanqiong, H., Abrar, M., Shabbir, R., & Rasheed, H. M. W. (2021). Role of brand experience in predicting consumer loyalty. *Marketing Intelligence & Planning*, 39(8), 1042–1057. (ahead-of-print). <https://doi.org/10.1108/MIP-11-2020-0471>
- Sarstedt, M., Ringle, C. M., & Hair, J. F. (2017). Handbook of market research. In *Handbook of market research* (Issue September). Cham: Springer. <https://doi.org/10.1007/978-3-319-05542-8>
- Schmidt, C. V. H., Kindermann, B., Behlau, C. F., & Flatten, T. C. (2021). Understanding the effect of market orientation on circular economy practices: The mediating role of closed-loop orientation in German SMEs. *Business Strategy and the Environment*. <https://doi.org/10.1002/bse.2863>
- Shafique, I., Kalyar, M. N., & Mehwish, N. (2021). Organizational ambidexterity, green entrepreneurial orientation, and environmental performance in SMEs context: Examining the moderating role of perceived CSR. *Corporate Social Responsibility and Environmental Management*, 28(1), 446–456. <https://doi.org/10.1002/csr.2060>
- Shahzad, M., Qu, Y., Javed, S., Zafar, A., & Ur Rehman, S. (2020). Relation of environment sustainability to CSR and green innovation: A case of Pakistani manufacturing industry. *Journal of Cleaner Production*, 253, 119938. <https://doi.org/10.1016/j.jclepro.2019.119938>
- Sharma, M., & Choubey, A. (2021). Green banking initiatives: a qualitative study on Indian banking sector. *Environment, Development and Sustainability*. <https://doi.org/10.1007/s10668-021-01426-9>
- Shrivastava, P., & Hart, S (1995). Creating sustainable corporations. *Business strategy and the environment*, 4(3), 154–165.
- Song, S., Hossain, M. A., Yin, X., & Hosain, M. S. (2021). Accelerating green innovation performance from the relations of network potential, absorptive capacity, and environmental turbulence. *Sustainability*, 13(14), 7765. <https://doi.org/10.3390/su13147765>
- Song, W., & Yu, H. (2018). Green innovation strategy and green innovation: The roles of green creativity and green organizational identity. *Corporate Social Responsibility and Environmental Management*, 25(2), 135–150. <https://doi.org/10.1002/csr.1445>
- Suhud, U. (2021). Influence of social media marketing, electronic word of mouth and consumer engagement to brand loyalty in Indonesia grab company. *International Journal of Business and Social Science Research*, 2(2), 16–26.
- Taylor, J. R., & Lovell, S. T. (2021). Designing multifunctional urban agroforestry with people in mind. *Urban Agriculture & Regional Food Systems*, 6(1), e20016. <https://doi.org/10.1002/uar.20016>
- Tekinbaş Özkaya, F., Durak, M. G., Doğan, O., Bulut, Z. A., & Haas, R. (2021). Sustainable Consumption of Food: Framing the Concept through. *Turkish Expert Opinions. Sustainability*, 13(7), 3946.

- Tunjungsari, H., Syahrivar, J., & Chairy, C. (2020). Brand loyalty as mediator of brand image-repurchase intention relationship of premium-priced, high-tech product in Indonesia. *Jurnal Manajemen Maranatha*, 20(1), 21–30. <https://doi.org/10.28932/jmm.v20i1.2815>
- UDSAI. (2009). *Creating a more environmentally sustainable apparel business: Policies for apparel brands and retailers*. Newark, DE: UDSA.
- van Boerdonk, P. J. M., Krikke, H. R., & Lambrechts, W. (2021). New business models in circular economy: A multiple case study into touch points creating customer values in health care. *Journal of Cleaner Production*, 282, 125375. <https://doi.org/10.1016/j.jclepro.2020.125375>
- Villagra, N., Monfort, A., & Sánchez Herrera, J. (2021). The mediating role of brand trust in the relationship between brand personality and brand loyalty. *Journal of Consumer Behaviour*, 20(5), 1153–1163. <https://doi.org/10.1002/cb.1922>
- Vinerean, S., & Opreana, A. (2021). Measuring customer engagement in social media marketing: A higher-order model. *Journal of Theoretical and Applied Electronic Commerce Research*, 16(7), 2633–2654. <https://doi.org/10.3390/jtaer16070145>
- Wang, C., Zhou, R., & Lee, M. K. O. (2021). Can loyalty be pursued and achieved? An extended RFD model to understand and predict user loyalty to mobile apps. *Journal of the Association for Information Science and Technology*, 72(7), 824–838. <https://doi.org/10.1002/asi.24448>
- Willis, M. (2021). Online brand communities and brand loyalty: Toward a social influence theory. In *The art of digital marketing for fashion and luxury brands* (pp. 153–177). Springer.
- Wongpich, S., Minakan, N., Powpaka, S., & Laohavichien, T. (2016). Effect of corporate social responsibility motives on purchase intention model: An extension. *Kasetsart Journal of Social Sciences*, 37(1), 30–37. <https://doi.org/10.1016/j.kjss.2016.01.010>
- Wu, J. S., Ye, S., Zheng, C. J., & Law, R. (2021). Revisiting customer loyalty toward mobile e-commerce in the hospitality industry: does brand viscosity matter? *International Journal of Contemporary Hospitality Management*, 33(10), 3514–3534. (ahead-of-print). <https://doi.org/10.1108/IJCHM-11-2020-1348>
- Xie, X., Huo, J., & Zou, H. (2019). Green process innovation, green product innovation, and corporate financial performance: A content analysis method. *Journal of Business Research*, 101, 697–706. <https://doi.org/10.1016/j.jbusres.2019.01.010>
- Xu, J., Ye, M., Lu, W., Bao, Z., & Webster, C. (2021). A four-quadrant conceptual framework for analyzing extended producer responsibility in offshore prefabrication construction. *Journal of Cleaner Production*, 282, 124540.
- Yan, M., Filieri, R., & Gorton, M. (2021). Continuance intention of online technologies: A systematic literature review. *International Journal of Information Management*, 58, 102315. <https://doi.org/10.1016/j.ijinfomgt.2021.102315>
- Zeren, D., & Kara, A. (2020). Effects of brand heritage on intentions to buy of airline services: The mediating roles of brand trust and brand loyalty. *Sustainability*, 13(1), 303–315. <https://doi.org/10.3390/su13010303>
- Zhao, H., Cheng, X., Wang, X., & Qin, C. (2021). Do brand micro-blogs entities' interactivity enhance customer's brand resonance? Evidence from China. *Asian Business & Management*, 20(3), 390–408. <https://doi.org/10.1057/s41291-019-00095-x>
- Zhou, Q., Yuen, K. F., & Ye, Y. (2021). The effect of brand loyalty and loss aversion on competitive trade-in strategies. *Total Quality Management & Business Excellence*, 1–29. <https://doi.org/10.1080/14783363.2021.1933423>
- Zittis, G., Hadjinicolaou, P., Almazroui, M., Bucchignani, E., Driouech, F., El Rhaz, K., Kurnaz, L., Nikulin, G., Ntoumos, A., Ozturk, T., Proestos, Y., Stenchikov, G., Zaaboul, R., & Lelieveld, J. (2021). Business-as-usual will lead to super and ultra-extreme heatwaves in the Middle East and North Africa. *NPJ Climate and Atmospheric Science*, 4(1), 1–9. <https://doi.org/10.1038/s41612-021-00178-7>
- Zou, C., Xue, H., Xiong, B., Zhang, G., Pan, S., Jia, C., Wang, Y., Ma, F., Sun, Q., Guan, C., & Lin, M. (2021). Connotation, innovation and vision of 'carbon neutrality'. *Natural Gas Industry B*, 8(5), 523–537. <https://doi.org/10.1016/j.ngib.2021.08.009>